

Year of Manufacture: 20 _____

Doc. # 01-18-008F

Original Instructions



S1-27/D4-KIT/D7-KIT ASSEMBLY

For Mounting V10-11 / V-100 / D-1000
E100 / E200

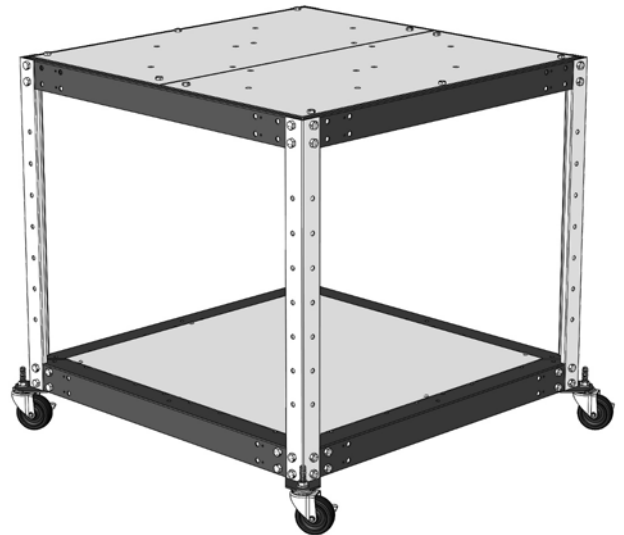
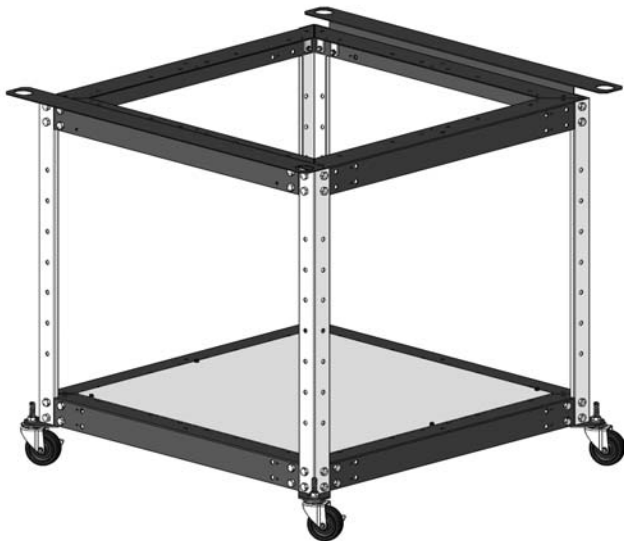

Contents	Page#
•S1-27 Assembly	2-3
•D4-Kit/D7-Kit Assembly	4-6
•Mount Assembly	7

Vastex International, Inc.
7 Emery St
Bethlehem, PA 18015-1982
Phone# 610-625-2702 Fax# 610-625-2775
Web Site www.vastex.com

Vastex E-mail assistance

Purchasing & Product Info:
sales@vastex.com

Electrical Support:
stech@vastex.com

Tech Support, Mechanical Setup, and Operation:
techsupport@vastex.com

Assembly

1) Remove all parts from the box they were shipped in.

2) Assemble S1-27 base using (4) Vertical Rails and (4) Horizontal Rails.

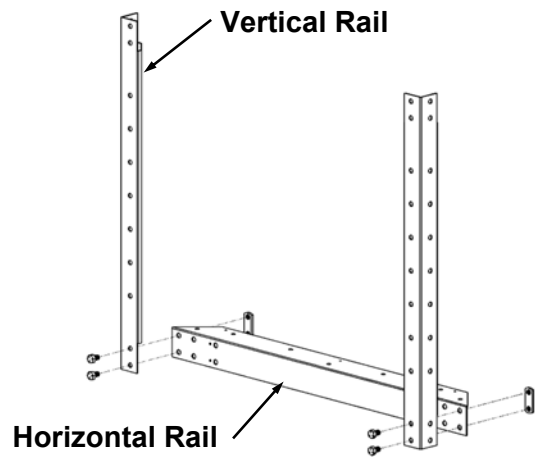

3) Install and **Leave Loose**
-(16) 5/16-18 x 1/2" Bolts
-(8) 5/16-18 Double Nuts

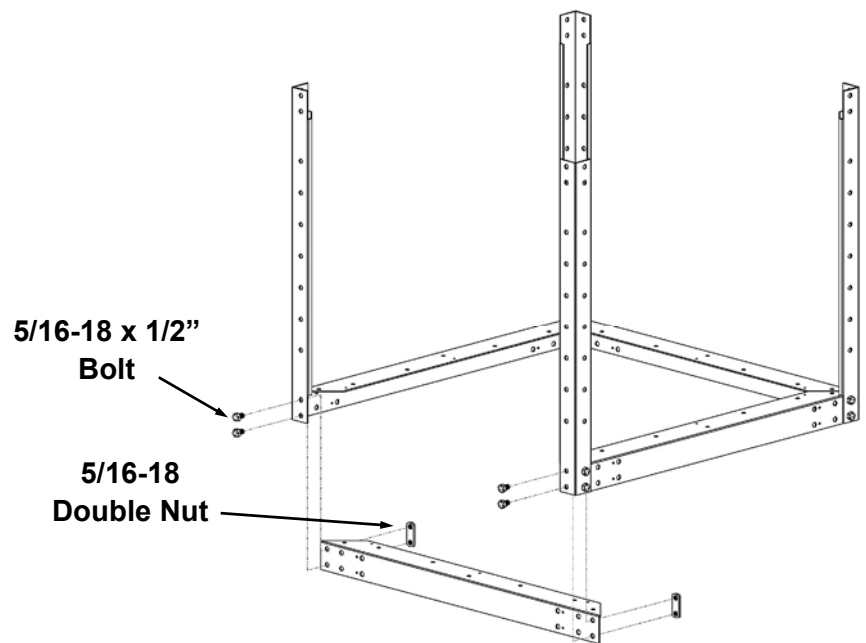

4) Install a Wheel Bracket on each corner.
Leave Loose for now.
-(4) 5/16-18 x 1/2 Bolts
-(2) 5/16-18 Double Nuts
-(1) Wheel Bracket

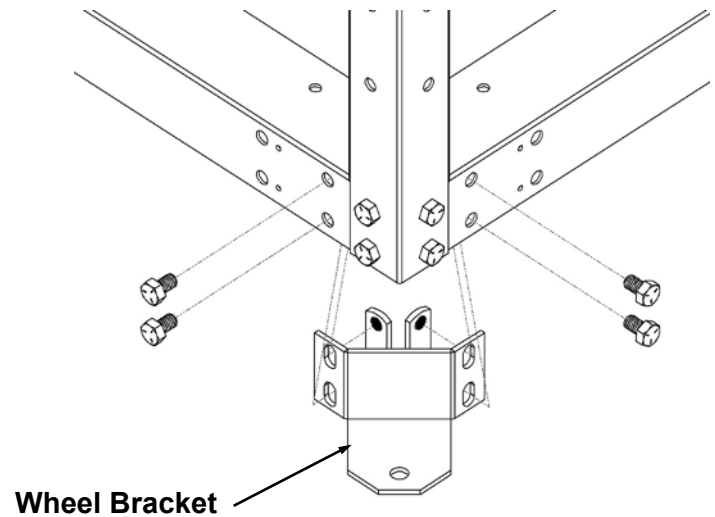

Assembly

- 5)** Use a carpenters square or equivalent to hold verticals square to horizontals.
Tighten ALL installed bolts with 1/2" or 13mm wrench while holding Vertical Square.

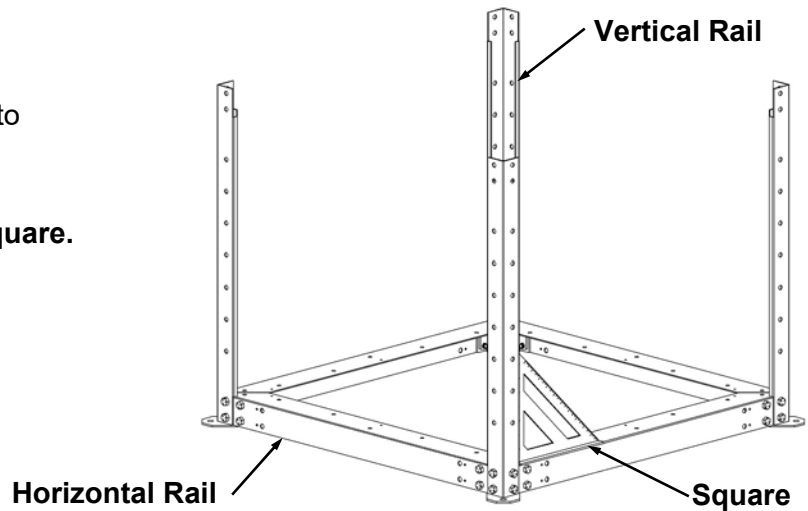

- 6)** Install A wheel on each wheel bracket.
Tighten well using 9/16" or 15mm wrench
- (1) Wheel with Stud
- (1) 3/8-16 Lock Nut

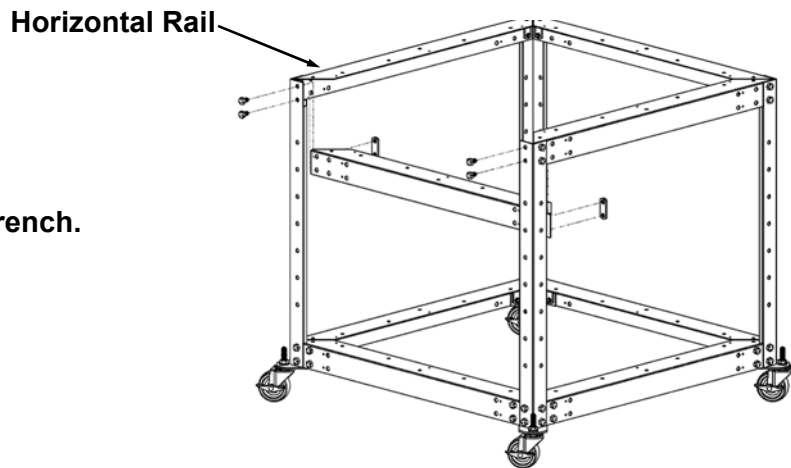
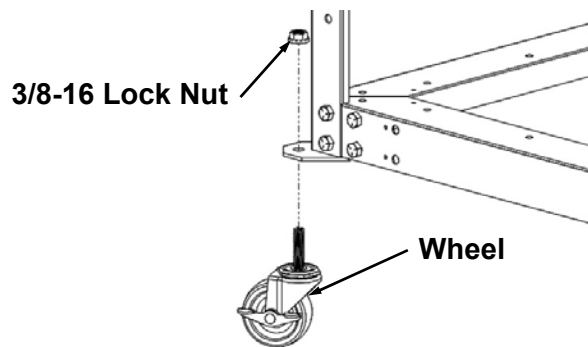

- 7)** Install (4) upper Horizontal Rails
Tighten Well using 9/16" or 15mm wrench.
- (16) 5/16-18 x 1/2" Bolts
- (8) 5/16-18 Double Nuts

- 8)** Install Lower Dust Cover
Tighten Well using Philips Head Screw Driver.
- (6) #8 Philips Head Sheet Metal Screw
- (1) Dust Cover

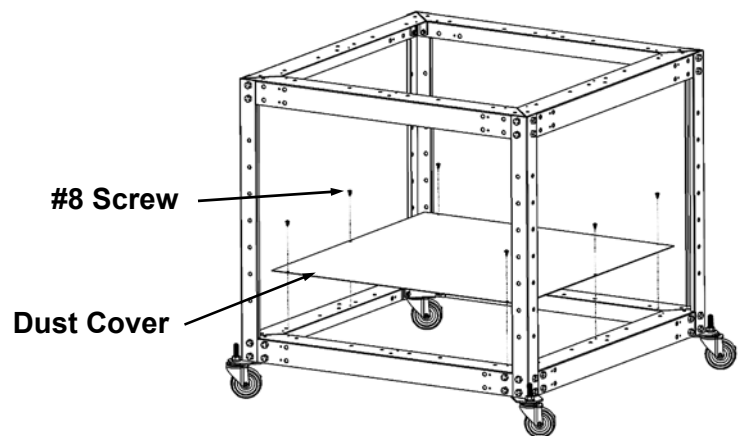

Assembly

- 9) Install (1) Nutplate in each corner using (1) 5/16-18 x 1/2" bolt to hold each in place. (2) Nutplates should be installed on (2) Sides. See photos for orientation.

Optional 3 Drawer Upgrade

- 9a) Install (1) Flat Nutplate in each corner using (1) 5/16-18 x 1/2" bolt to hold each in place. (2) Flat Nutplates should be installed on (2) Sides.

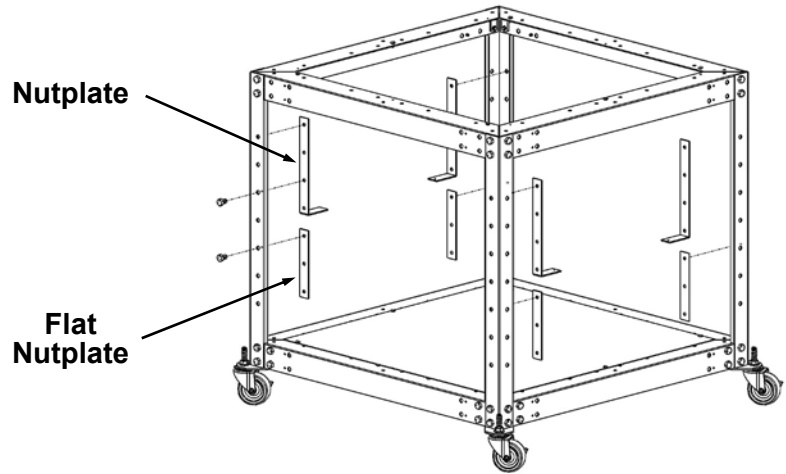

- 10) Install Drawer Slides as shown. Fixed wheel must be positioned in front of assembly. Push Slide towards outside of assembly while tightening.

Tighten well using 1/2" wrench
-(2) 5/16-18 x 1/2" Bolt (each slide)

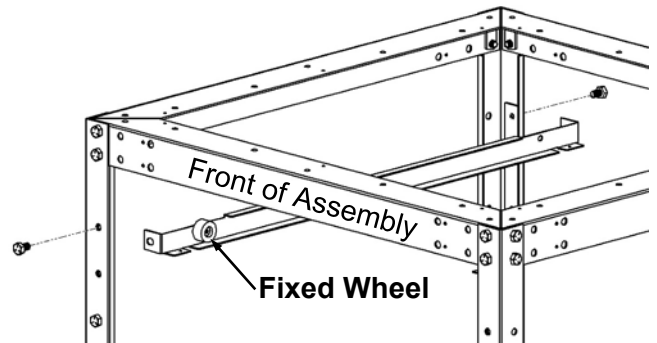

- 10a) Your drawer slides will be assembled from the factory.

See below diagrams for reference.

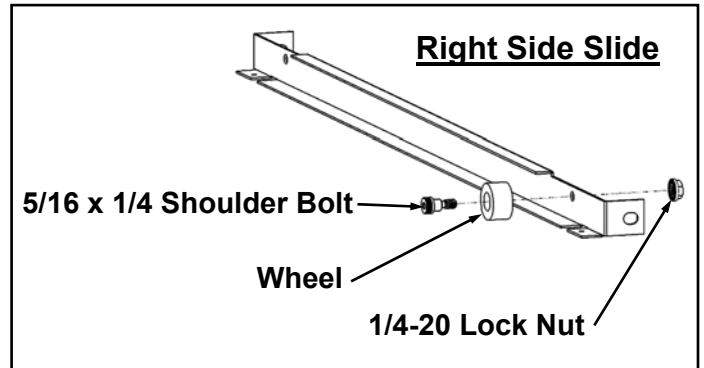
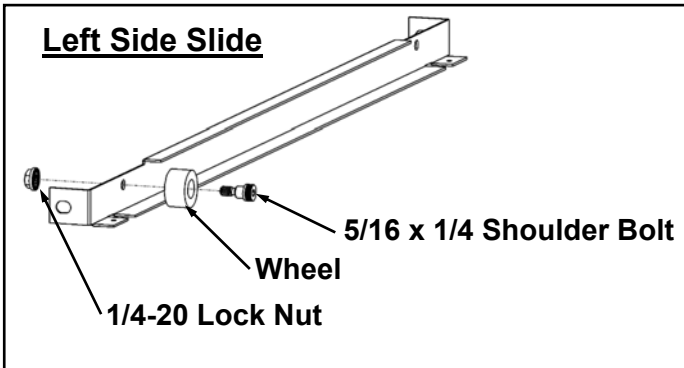

- 11) Remove 5/16-18 bolt used for holding mount angle and install all remaining Drawer Slides.

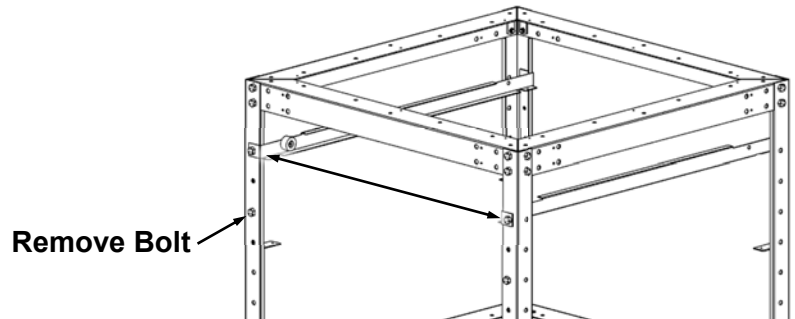

Push slide towards outside while tightening mounting bolts

Assembly

12) Slide All Drawer Assemblies into assembly from the REAR of stand. Drawers have wheels preinstalled on rear from factory.

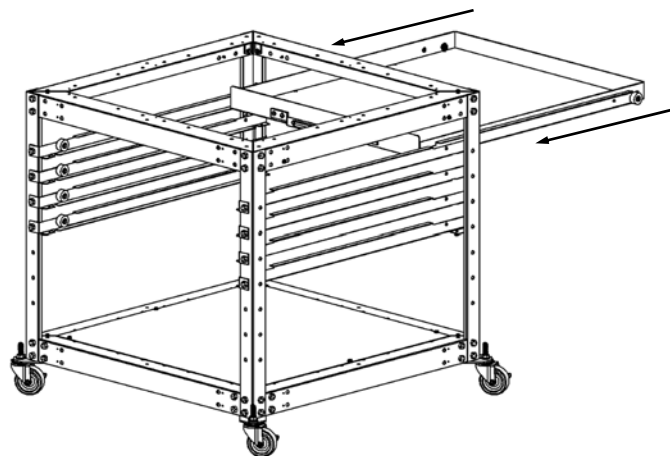

7 Drawers

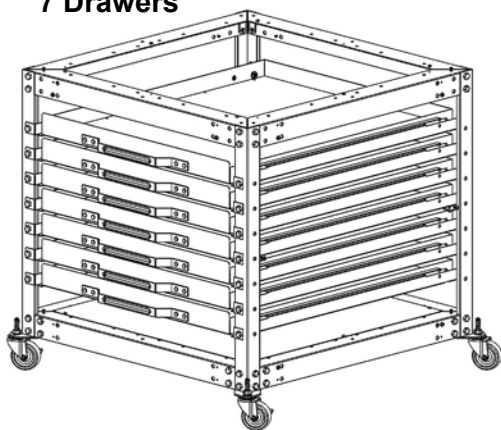

4 Drawers

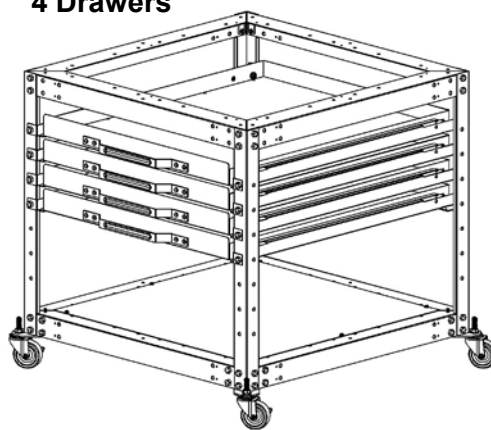

13) Install Tall Skins on 3 sides as shown. Tighten well using 1/4" nut driver or flat blade screw driver

- (2) Tall Skin w/ Screen Print
- (1) Tall Skin, No Screen Print (rear)
- (4) #8 Sheet Metal Screws (each skin)

Tall Skin W/ screen print Tall Skin No screen print

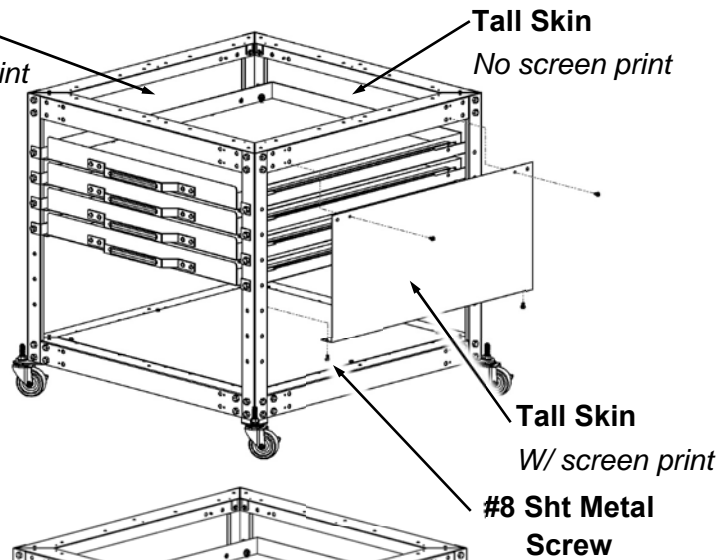

14) Install front Short Skin Tighten well using 1/4" nut driver or flat blade screw driver

- (1) Short Skin
- (2) #8 Sheet Metal Screws

Short Skin #8 Sht Metal Screw

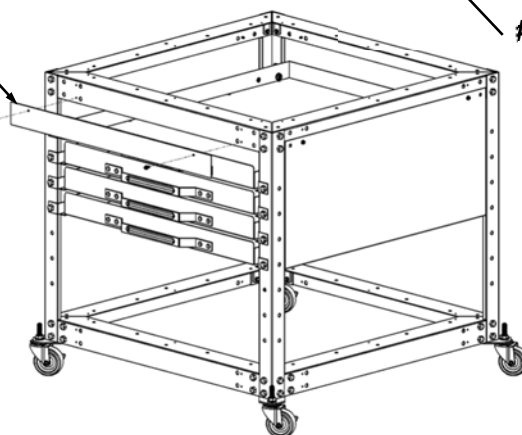

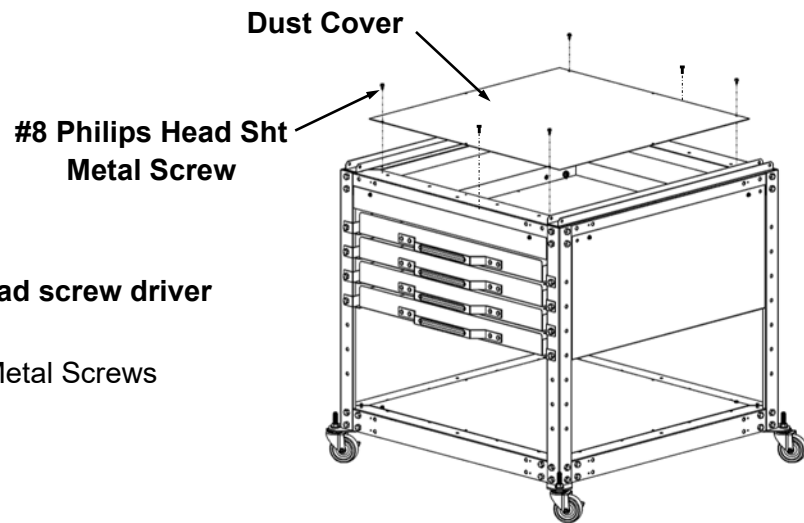

15) Install Top Dust Cover

Tighten well using Philips Head screw driver

- (1) Dust Cover
- (6) #8 Philips Head Sheet Metal Screws

Optional 3 Drawer Upgrade

16) Install Lower Skins on 3 sides as shown.

Tighten well using 1/4" nut driver or flat blade screw driver

- (3) Lower Skin
- (4) #8 Sheet Metal Screws (each skin)

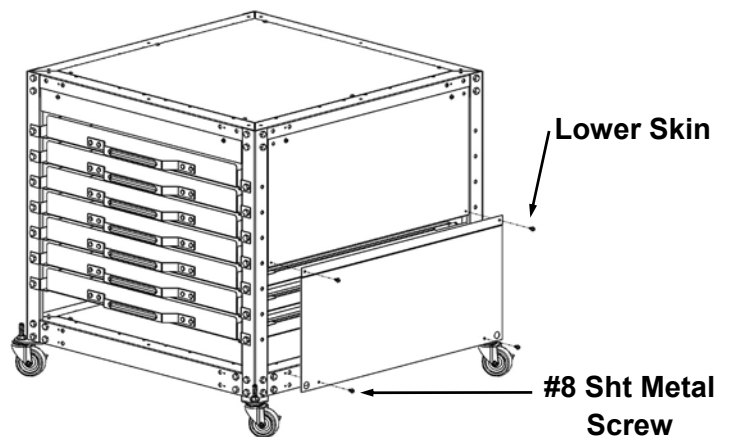

— Assembly (Printer Mount)

1) Install Top Mount Panels
Tighten well using (2) 7/16" or
11mm wrenches

- (2) Top Mount Panels
- (10) 1/4"-20 x 1/2" Bolts
- (10) 1/4" Lock Nuts

Top Mount Panel

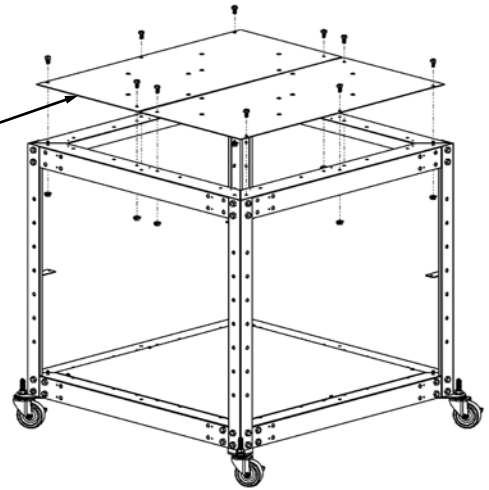

— Assembly (D1000 / E100 / E200 Mount)

1) Install Mount Angles
Tighten well using 1/2" or
13mm wrenches

- (2) Mount Angles
- (4) 5/16"-18 x 1/2" Bolts
- (4) 5/16"-18 Serrated Nuts

5/16"-18 x 1/2" Bolt

Mount Angle

Serrated Nut

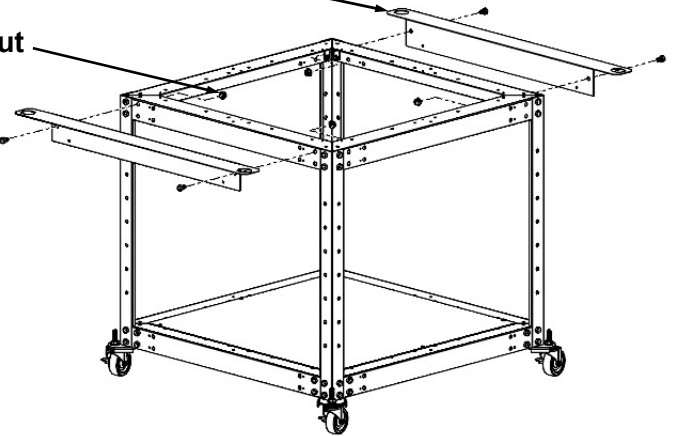

Angles face OUT for
E-100/E-200/D-1000

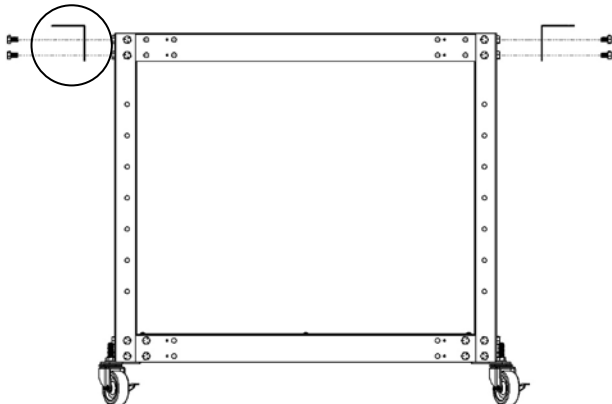

Angles face IN for D-1000
without 10" extension

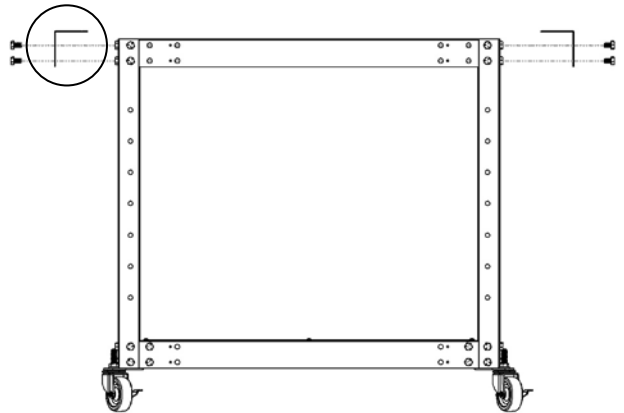

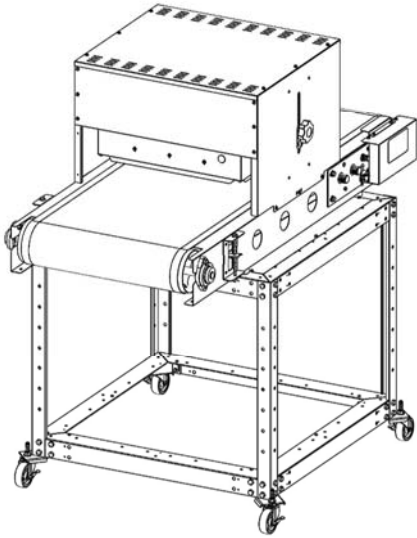

D-100

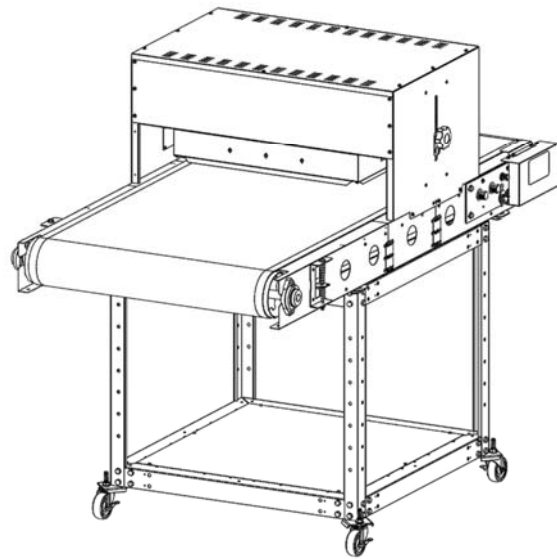

D-1000

****May require front feet to be moved to back position closer to the conveyor extension****

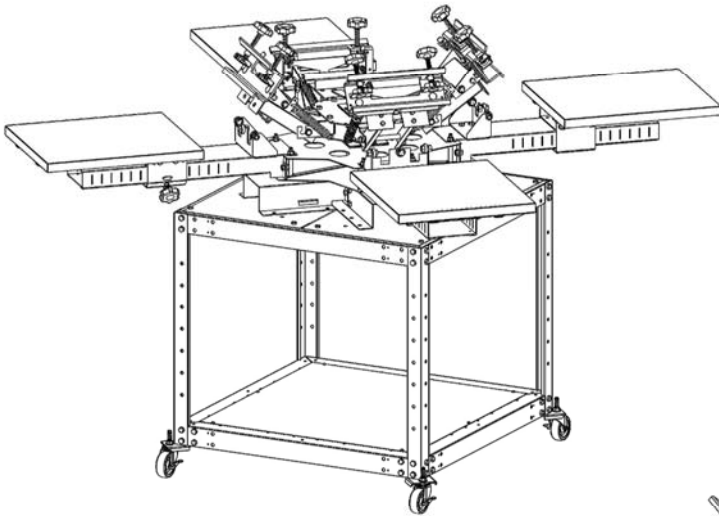

V-100

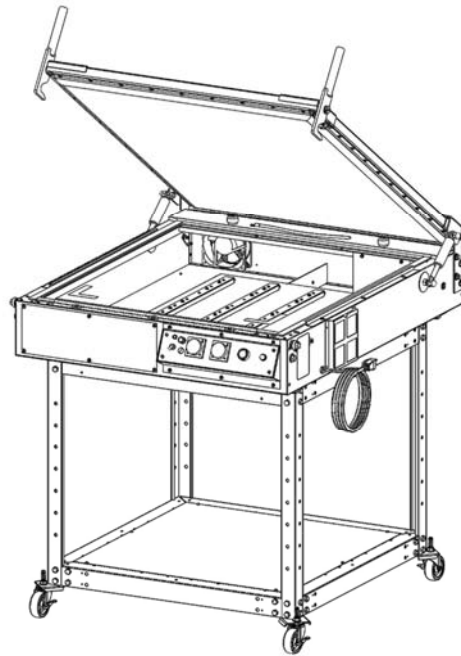

E100/E200

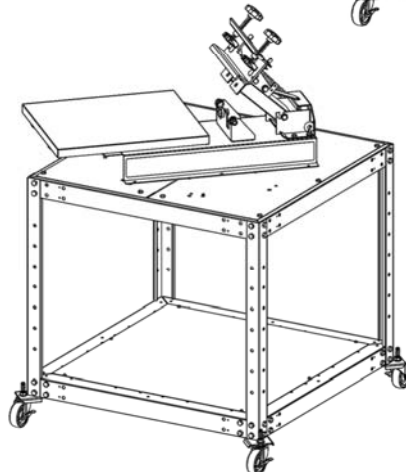

V10-11