



USER'S MANUAL

For Safe Use / Basic Operation

TMEZ-SC

Foreword

Thank you for purchasing the TAJIMA embroidery machine.

Please read this manual thoroughly, understand the contents, and then use the machine.

This manual may contain discrepancies in detailed specifications when compared with the actual product. If you have any question, please ask the distributor for information.

Purpose of This Document

This manual and other documents contain the following information. Refer to the necessary documents depending on the application and purpose. Documents other than “For Safe Use” and “Basic Operation” are stored as PDF files on the supplied CD.

USER'S MANUAL

CD-ROM (PDF)

This document (Print version)

For Safe Use

This manual contains instructions on using the machine safely. Make sure to read the manual before use.

Basic Operation

This manual describes the basic procedures for operating the machine, performing embroidery, and performing maintenance.

Basics

This manual describes the basic knowledge and procedures that are common to all the models and required to use the machine.

If you are a novice to or unfamiliar with the machine, be sure to read this manual first.

Advanced Operation

This manual describes the procedures for using advanced machine functions and operations for users familiarized with basic operations.

Parameter Setting

This manual describes various parameters.

Frame Change

This manual describes how to change the frames.

This does not come with some models.

Various Documents

Electrical system diagrams and other technical documents.

Other manuals

Quick Guide

This sheet is the Quick reference regarding embroidery methods as well as frequently used functions and their operation procedures.



Keep the Quick Guide handy so that you can reference it quickly.

Optional Device

This manual describes how to set up, operate, and maintain various optional devices.

Safety Precautions and Symbols



Items that require your special attention on handling the machine are specified below.

Description	Meaning
 DANGER	Indicates that there is a lot of danger of death or serious injuries* ¹ .
 WARNING	Indicates that there is a likelihood of death or serious injuries* ¹ .
 CAUTION	Indicates a potentially hazardous situation which may result in minor or moderate injury* ² or physical damage.



*1: A condition caused by electric shock, injury, fracture of a bone etc. that leads to aftereffects, or an injury that necessitates hospitalization or visits to a hospital over a long period.

*2: An injury that does not necessitate hospitalization or visit to a hospital over a long period.

The symbols used throughout this document have the following meanings.

Symbol	Meaning
	Item to be prohibited
	Items that may cause electric shock if not observed
	Items to keep safety

Other Precautions

Description	Meaning
	Items that may affect sewing if not observed.
	Recommended and useful tips.

Disclaimer, etc.

- The external views and specifications of the machine and the contents of this manual are subject to change without notice due to improvement.
- The screen captures and figures contained in this manual may differ depending on the machine specifications, the number of heads or needles, and the presence of optional device.
- TAJIMA bears no responsibility regarding any damage arising from not observing the instructions in the manual or any fault or damage resulting from repair, disassembly, or modification not indicated in the manual.
- You may not copy, reproduce, or transcribe a part or whole of this manual without consent of TAJIMA.

For Safe Use

Chapter 1 For Safe Use

1. Precautions in Handling	10
2. Power Supply Precautions	13
3. Important Warning Items for Safe Operation (for the US and Canada Market) . . .	15

Chapter 2 About Warning Labels

1. Type of Warning Labels	18
2. Attaching Positions	19

Chapter 3 Safety Device

1. Emergency Stop Switch	21
1-1. Emergency stop switch locations	21
1-2. Operating the emergency stop switch	22
1-3. Resetting the emergency stop switch	23

Basic Operation

Chapter 1 Basic Operation of the Machine

1. Turning ON/OFF the Power	28
1-1. Turn ON the power	28
1-2. Turn OFF the power	29
2. Start and Stop of the Machine	30
2-1. Start the machine	30
2-2. Stop the machine	30
3. Multi-color LEDs	31
4. Direct Command Switch	32

5. Screen Operations	34
5-1. Main screen	35
5-2. Design selection screen	36
5-3. Description of basic icons	37
6. Travel of Frame	39
6-1. How to move the frame	39
6-2. Changing the travel speed	39
6-3. Checking the frame position (coordinates)	40
7. Data Input/Output	41
7-1. Connecting a USB memory	41
7-2. Connecting a LAN cable	41

How to Embroider

1. Basic Flow of Embroidery	42
2. Embroidery Procedures	43
2-1. Saving or Storing designs into the machine memory	43
2-2. Selecting the embroidery design (data setting)	45
2-3. Setting of needle bar step	47
2-4. Confirmation of design	48
2-5. Setting the embroidery speed (Maximum R.P.M.)	49
2-6. Checking the embroidery position (execution of trace)	50
2-7. Starting embroidery	52
2-8. Completion of embroidery	53
3. Making Use of DCP	54
3-1. Setting items for presser foot	54
3-2. About Setting Operation	56
3-3. Settings on needle bar setting screen	57
3-4. Settings on manual operation screen	58
4. Responding to Thread Breakage	59
4-1. How to respond to a thread breakage indicator	59
4-2. Repair stitches	60

1. Features of i-TM	62
2. i-TM Operation Screen	63
3. Adjusting the Finish of Sewing	64
3-1. Adjusting the thread tightening	64
3-2. Adjusting the thread tightening during operation	66
4. Storing the Control Pattern (Pattern Number)	68
4-1. Storing the control pattern with a name	68
4-2. Overwriting and saving the control pattern	69
5. Dividing Step	70
5-1. Dividing step and setting	70
5-2. Deleting divided step	73
6. Resetting of the Control Pattern	74
6-1. Resetting of the selected control pattern	74
6-2. Batch resetting of all the control patterns	75
7. List Display and Editing of Control Patterns	76
7-1. List display of control patterns	76
7-2. Searching control pattern by name	77
7-3. Adjusting fabric thickness and stitch thread tightening (detailed setting screen)	77
7-4. Deleting control pattern	78
7-5. Changing control pattern name	79

1. Moving Back or Moving Forward the Frame along the Stitches	80
1-1. Frame Back/Frame Forward by 1-stitch unit	81
1-2. Frame Back/Frame Forward by specifying the number of stitches	82
1-3. Frame Back/Frame Forward by specifying the number of color change	83
2. Thread Trimming	84
2-1. Operating the ATH	84

3. Needle Bar Related Operations	85
3-1. Color Change	85
3-2. Raising or lowering the needle bar	86
3-3. Stopping the needle bar at the lower dead point	87
3-4. Raising or lowering the presser foot	88
4. Various Frame Movement Operations	89
4-1. Moving the frame to the preset optional position	89
4-2. Moving the frame to the original position (manual offset)	90
4-3. Moving the frame to the start position	90
4-4. Moving the frame to the offset position	91
4-5. Moving the frame by entering a numeric value	92
4-6. Absolute origin search	93
4-7. Power Resume	94
5. Other Operation	95
5-1. Turning ON/OFF the LED lamp	95

Deleting or Saving Designs

1. Deleting Designs	96
1-1. Deleting a design in the machine memory (one design at a time)	96
1-2. Deleting designs in the machine memory (two or more designs at once)	97
1-3. Deleting designs in the USB memory	99
2. Saving Designs	100
2-1. Saving designs in the USB memory	100
2-2. Changing the design storage location	103
2-3. Changing a design name	104

Maintenance

1. Precautions for Maintenance	105
2. Maintenance Item List	106
3. Cleaning	107
3-1. Inside of the cylinder bed	107
3-2. Head and its surroundings	108
3-3. X-axis drive system, Y-axis drive system	109
3-4. Presser foot shaft	109
4. Lubrication	110
4-1. Rotary hook	110
4-2. Inside of head	111
5. Greasing	112
5-1. Cylinder bed gear	112
5-2. Inside of head	113
6. Inspection and Repair	114
6-1. Inspection of drive systems and sliding parts	114
6-2. Repair	114
7. Checking and Adjustment	115
7-1. Checking the needle bar lower dead point	115
7-2. Adjusting the stroke amount of the thread take-up spring	117
8. Others	119
8-1. Precautions to take when installing the tension base cover	119

Troubleshooting

1. Message Screen	120
2. When the Machine Does not Sew Well	125
2-1. Frequent thread breakages	125
2-2. Needle breaks	125
2-3. Embroidery results not good	126
3. Power Resume after Power Failure	127
4. Obtaining Log Data	128

Appendix

1. Specifications	129
1-1. Electrical specifications	129
1-2. Ambient noise level	129
1-3. Machine weight	129
2. Terminology	130

For Safe Use

This manual contains instructions on using the machine safely. Make sure to read the manual before use.

Chapter 1	For Safe Use	10
Chapter 2	About Warning Labels	18
Chapter 3	Safety Device	21









Chapter 1

For Safe Use

Observe the following precautions to prevent fire or electric shock, personal damage and injury, fire and other damage to property arising from misuse of the product.

1. Precautions in Handling

WARNING

-  **DO NOT USE THE MACHINE FOR OTHER THAN ITS INTENDED PURPOSE**
The TAJIMA embroidery machine is an industrial machine. Do not use the machine for other than embroidery on semi- or finished textile products and similar materials.
-  **DO NOT DISASSEMBLE, REPAIR, OR MODIFY THE MACHINE**
Failure to observe this may result in fire or electric shock, injury, or fault. If repair is necessary, consult the distributor.
-  **DO NOT USE THE BAR SWITCH AS A GRIP**
For machine models with a bar switch, using the bar switch as a grip to support yourself is strictly prohibited. Failure to observe this may cause the machine to start unexpectedly, possibly resulting in an injury.
-  **KEEP AWAY FROM DEVICES THAT GENERATE ELECTROMAGNETIC WAVES**
Do not use a device such as a cellular phone that generates microwaves near the control circuits of the power supply box, the operation panel, etc.
Microwaves may cause malfunctioning of the machine.
-  **DO NOT REMOVE COVERS**
Do not remove the covers for shafts, pulleys, etc. Also, do not run the machine with a cover removed. Failure to observe this may result in being caught in moving parts.
-  **DO NOT BRING YOUR HANDS OR FACE CLOSE TO MOVING PARTS WHILE THE MACHINE IS RUNNING**
Do not bring your hands or face close to the needles, rotary hooks, take-up levers, or frame drive systems while the machine is running. Failure to observe this may result in an injury such as caused by piercing by a needle, etc., spattering of broken needle pieces, or contact with the rotary hook or frame.
-  **KEEP CHILDREN AWAY FROM THE MACHINE**
Keep children away from the machine to prevent an accident.
-  **DO NOT ALLOW IMPLANTED ELECTRONIC MEDICAL DEVICES TOO CLOSE TO THE EMBROIDERY MACHINE**
A strong magnet is used inside the machine (the tension base), which may cause magnet-sensitive devices, such as cardiac pacemakers, to malfunction. If you feel something wrong with your body, leave the machine immediately.

WARNING

- ! FAMILIARIZE YOURSELF WITH HOW TO OPERATE THE MACHINE BEFORE ACTUAL USE**

Please read the manual thoroughly and understand the instructions. Then, operate the machine. Be sufficiently trained on how to operate the machine before actual use. If you are disabled or not familiar with how to operate the machine, use the machine under supervision and instructions of an authorized administrator or supervisor.
- ! WEAR PROPER CLOTHES AND TIDY UP YOURSELF SO THAT YOU CAN SMOOTHLY PERFORM THE OPERATION**

Do not wear clothes or accessories that may be caught in moving parts when operating the machine.
- ! A SINGLE OPERATOR SHOULD OPERATE THE MACHINE**

To prevent an accident due to an unexpected startup, a single operator should operate the machine in principle. If plural operators are working together, make sure that no one is working near the moving parts of the machine before starting the machine.
- ! USE THE MACHINE IN THE ENVIRONMENT WHERE ONLY AUTHORIZED PERSONS ARE PERMITTED TO ENTER**

Ensure that unauthorized persons will not operate the machine.
- ! STOP THE MACHINE BEFORE CHECKING THE FINISHING OF EMBROIDERY**

Do not bring your hands or face close to moving parts. Failure to observe this may result in injury due to contact with needles or frames.
- ! TURN OFF THE POWER BEFORE PERFORMING ANY OF THE FOLLOWING TASKS**

To prevent an accident due to an unexpected startup, be sure to turn OFF the power before:

 - Replacing the needle
 - Performing time-consuming threading or under thread replacement
 - Stretching the fabric on the border frame
 - Stepping on the table
 - Accessing the rear of the machine
- ! UNPLUG THE POWER PLUG FROM THE OUTLET IN THE FOLLOWING CASES**

Turn OFF the machine and unplug the power plug from the outlet in the following cases. Failure to observe this may result in fire or electric shock, fault, or accident.

 - After use of the machine
 - If the machine is not used for a long period
 - Before performing machine adjustment, lubrication, or maintenance
 - Before leaving the machine
 - When thunder is heard
- ⊘ DO NOT RUN THE MACHINE WITH THE SUB TABLE LOWERED**

For machine models with a sub table, lift up and fix the sub table securely after threading and/or adjusting the machine. Failure to observe this may result in an accident due to being caught in the frame, for example.

WARNING

- ! IMMEDIATELY STOP THE MACHINE IF THERE IS SMOKE, ABNORMAL ODOR, OR ABNORMAL SOUND**
If the machine behaves abnormally, immediately turn OFF the power to stop using it.
In addition, unplug the power plug from the outlet and consult your local distributor.
- ! ADJUSTMENT AND MAINTENANCE SHOULD BE PERFORMED BY PERSONNEL WHO HAS BEEN TRAINED PROPERLY**
Be sufficiently trained and instructed on how to perform maintenance work such as lubrication and adjustment before actually doing so. Greasing, inspection of drive systems, and repair of the machine must be performed by your local distributor or the service personnel assigned and trained by Tajima.
Failure to observe this may result in injury, electric shock, or other serious accident.
- ! SHOULD THE MACHINE CATCH FIRE, DISTINGUISH THE FIRE USING A FIRE EXTINGUISHER FOR ELECTRICAL FIRE**

CAUTION

- ! PRE-CONDITIONING INTERIM OPERATION SHOULD BE PERFORMED FOR ABOUT ONE WEEK AFTER THE INSTALLATION OF THE MACHINE**
For using the machine for a long time and preventing unexpected trouble, operate the machine with about 70% of the maximum speed as pre-conditioning interim operation.
- ⊘ DO NOT USE BENT NEEDLES OR NEEDLES THAT ARE NOT SUITABLE FOR THE MATERIAL**
- ⊘ DO NOT PUT THINGS ON THE MACHINE TABLE**
- ! WHEN YOU STEP ON THE TABLE TO PERFORM THE WORK, OBSERVE THE FOLLOWING PRECAUTIONS**
 - Support the table with the supplied support
Do not step on the table unless it is supported with the support. The table may be deformed.
 - Do not stomp on the frame drive system, frame, etc.
Failure to observe this may result in damage.
- ⊘ DO NOT PULL OR PUSH THE FABRIC DURING EMBROIDERY**
- ! PERFORM MAINTENANCE WORK PERIODICALLY**
Lack of maintenance may result in early deterioration or failure of parts.
Damage arising from lack of maintenance may be excluded from the scope of guarantee.
- ⊘ DO NOT SEW HARD AND/OR THICK MATERIAL THAT NEEDLE CANNOT GO THROUGH**
- ! WHEN YOU DISPOSE OF THIS MACHINE, BE SURE TO COMPLY WITH THE REGULATION OF YOUR COUNTRY**

2. Power Supply Precautions

WARNING

-  **DO NOT OPEN ELECTRICITY BOXES**

The electricity boxes must not be accessed by other than the service personnel assigned and trained by Tajima. Contact with high-voltage parts inside the boxes may result in electric shock.
-  **PROPERLY HANDLE THE POWER AND OTHER CABLES**

Observe the following precautions. Improper handling may cause the cable to break, possibly resulting in fire or electric shock due to current leakage.

 - Do not scratch, heat, or modify the cables
 - Do not forcibly pull, bind, twist, or fold the cables
-  **IMMEDIATELY STOP THE MACHINE IF THE POWER CABLE OR PLUG IS DAMAGED**

Breakage of the power cable or plug may result in fire or electric shock due to current leakage. Do not use the machine if the power cable or plug is broken. In addition, unplug the power plug from the outlet and consult your local distributor.
-  **DO NOT PLUG OR UNPLUG THE POWER PLUG WITH WET HANDS**

Failure to observe this may result in electric shock.
-  **SECURELY INSERT THE POWER PLUG UNTIL COMPLETE CONTACT**

If the power plug electrodes come in contact with a metal object, fire or electric shock may result.
-  **UNPLUG THE POWER PLUG WHILE HOLDING IT**

Do not pull the power cable because doing so may cause the power cable to break with its core wires exposed or disconnected, possibly resulting in fire or electric shock due to current leakage.
-  **KEEP ELECTRIC AND ELECTRONIC UNITS AWAY FROM WATER AND CHEMICALS**

Failure to observe this may result in short-circuiting, possibly resulting in fire or electric shock. Do not use the machine if water or chemical enters it. In addition, unplug the power plug from the outlet and consult your local distributor.

CAUTION

In addition to the leakage current, a leakage current consisting of harmonics and surges flows in the power supply line of the machine. Therefore, the improper selection and installation of an earth leakage circuit breaker and/or earth leakage relay for the factory may cause the machine to malfunction. Follow the instructions below for connecting the power cord.

! USE AN EARTH LEAKAGE CIRCUIT BREAKER AND EARTH LEAKAGE RELAY WITH HARMONIC AND SURGE PROTECTION FOR THE POWER SUPPLY LINE

If you cannot obtain an earth leakage circuit breaker or earth leakage relay with harmonic and surge protection and you have to use those with no harmonic and surge protection, make sure that they have high leakage capacitance so as to accommodate the leakage current resulting from harmonics and surges. Also, always control the amount of leaked current sufficiently.

! CONNECT THE POWER CORD OF A SINGLE EMBROIDERY MACHINE TO ONE NO-FUSE BREAKER

Not doing so may cause problems, such as an output reduction of the main shaft motor, a fixed position error that will accompany a color change error, or a design displacement. Contact your distributor for the required leakage capacitance of the earth leakage circuit breaker and earth leakage relay for each machine. For specific products with harmonic and surge protection, contact the distributor or a professional electrical engineer.

3. Important Warning Items for Safe Operation (for the US and Canada Market)

IMPORTANT SAFETY INSTRUCTIONS

Read all instructions before using this appliance

When using an electrical appliance, basic safety precautions should always be followed, including the following:











DANGER

To reduce the risk of electric shock:







-  An appliance should never be left unattended when plugged in. Always unplug this appliance from the electric outlet immediately after using and before cleaning.

WARNING

To reduce the risk of burns, fire, electric shock, or injury to persons:

-  Do not allow to be used as a toy. Close attention is necessary when this appliance is used by or near children.
-  Use this appliance only for its intended use as described in this manual. Use only attachments recommended by the manufacturer as contained in this manual.
-  Never operate this appliance if it has a damaged cord or plug, if it is not working properly, if it has been dropped or damaged, or dropped into water. Please consult the nearest authorized dealer or service center and use this appliance after the examination, repair, electrical or mechanical adjustment has been made.
-  Never operate the appliance with any air openings blocked. Keep ventilation openings of the sewing machine free from the accumulation of lint, dust, and loose cloth.
-  Keep fingers away from all moving parts. Special care is required around the sewing machine needle.
-  Always use the proper needle plate. The wrong plate can cause the needle to break.
-  Do not use bent needles.
-  Do not pull or push fabric while stitching. It may deflect the needle causing it to break.
-  Switch the sewing machine off ("O") when making any adjustments in the needle area, such as threading needle, changing needle, threading bobbin, or changing presser foot, etc.
-  Always unplug sewing machine from the electrical outlet when removing covers, lubricating, or when making any other user servicing adjustments mentioned in the instruction manual.

WARNING



-  Never drop or insert any object into any opening.
-  Do not use outdoors.
-  Do not operate where aerosol (spray) products are being used or where oxygen is being administered.
-  To disconnect, turn all controls to the OFF ("O") position, then remove plug from outlet.
-  Do not unplug by pulling on cord. To unplug, grasp the plug, not the cord.
-  Connect this appliance to a properly grounded outlet only. See Grounding Instructions.

SAVE THESE INSTRUCTIONS

GROUNDING INSTRUCTIONS

This product must be grounded. In the event of malfunction or breakdown, grounding provides a path of least resistance for electric current to reduce the risk of electric shock. This product is equipped with a cord having an equipment-grounding conductor and a grounding plug. The plug must be plugged into an appropriate outlet that is properly installed and grounded in accordance with all local codes and ordinances.

DANGER

-  Improper connection of the equipment-grounding conductor can result in a risk of electric shock. The conductor with insulation having an outer surface that is green with or without yellow stripes is the equipment-grounding conductor. If repair or replacement of the cord or plug is necessary, do not connect the equipment-grounding conductor to a live terminal.
-  Check with a qualified electrician or serviceman if the grounding instructions are not completely understood, or if in doubt as to whether the product is properly grounded.
-  Do not modify the plug provided with the product - if it will not fit the outlet, have a proper outlet installed by a qualified electrician.

⚠ DANGER

! [If the product is used in a nominal rating up to 120V]

This product is for use on a nominal 120V circuit, and has a grounding plug that looks like the plug illustrated in sketch A in Figure-1. A temporary adaptor, which looks like the adaptor illustrated in sketches B and C, may be used to connect this plug to a 2-pole receptacle as shown in sketch B if a properly grounded outlet is not available. The temporary adaptor should be used only until a properly grounded outlet can be installed by a qualified electrician. The green colored rigid ear, lug, and the like, extending from the adaptor must be connected to a permanent ground such as a properly grounded outlet box cover. Whenever the adaptor is used, it must be held in place by the metal screw.

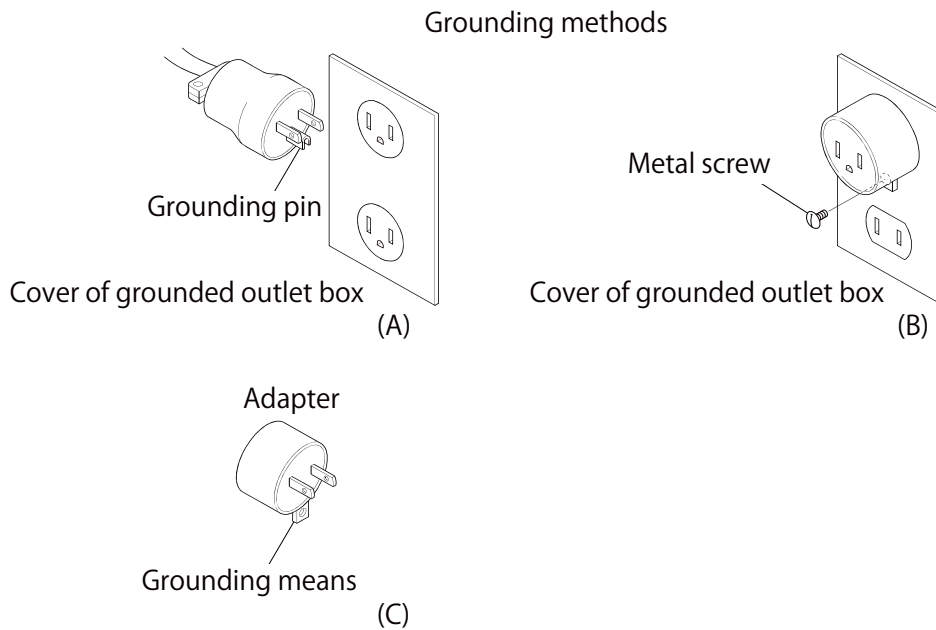

⊘ [If the product is used in a nominal rating more than 120V]

This product is for use on a circuit having a nominal rating more than 120V, and is factory equipped with a specific electric cord and plug. No adaptor should be used with this product. If the product must be reconnected for use on a different type of electric circuit, the reconnection should be made by qualified service personnel; and after the reconnection, the product should comply with all local codes and ordinances.

Chapter 2

About Warning Labels

Warning labels are attached to the machine to indicate the parts that may pose potential danger when you operate the machine or perform maintenance work. Observe the precautions indicated on the warning labels when using the machine.

Warning



Do not peel or scratch the warning labels. If a warning label is lost or becomes illegible, consult your local distributor. When reattaching a warning label, ensure that the label is in the original position.

1. Type of Warning Labels

The following warning labels are attached to the machine.

A Pay attention not to be caught into the machine.



F Pay attention to high voltage.



There could be danger of electric shock, burn, or death. Anyone other than the service personnel designated by Tajima should not open the cover. When opening the cover, turn OFF the power switch and wait for four minutes.

B Pay attention around needle.

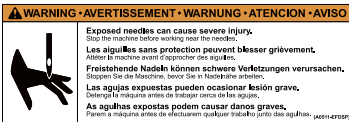

G Pay attention not to be caught into the machine.



There could be danger of being caught. Anyone other than the service personnel designated by Tajima should not open the cover.

C Pay attention not to be clipped into the machine.



H Pay attention not to be clipped into the machine.



There could be danger of being clipped. Do not bring your hands or face close to moving parts during operation.

D Pay attention not to be clipped into the machine.



I Pay attention to high temperature.



You could be burnt by high temperature. Do not touch carelessly.

E Pay attention to dropping.

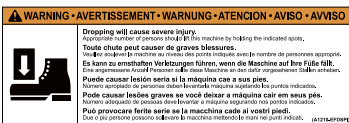

J Laser Product Class 1



K Pay attention to rotary hook.



2. Attaching Positions

The following figures show where the warning labels are attached for each model.

■ TMCR-VF, TMCP-VF

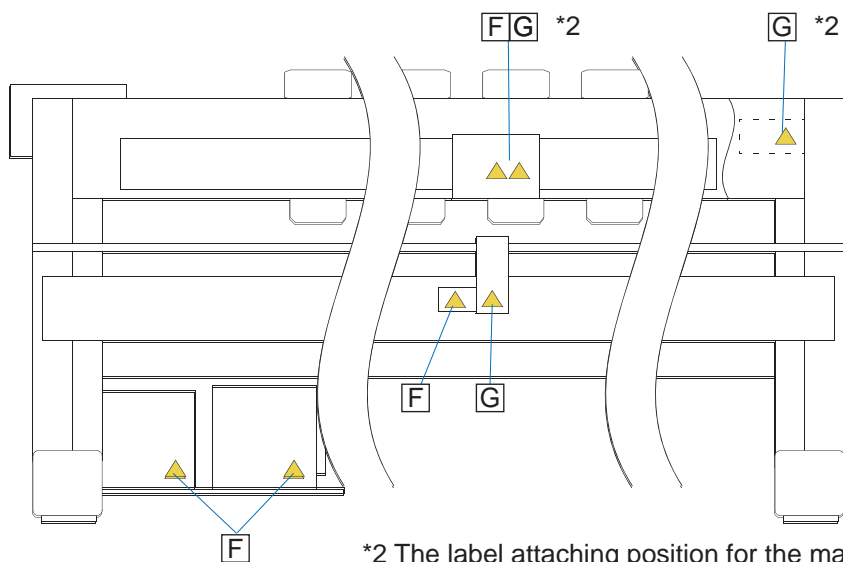
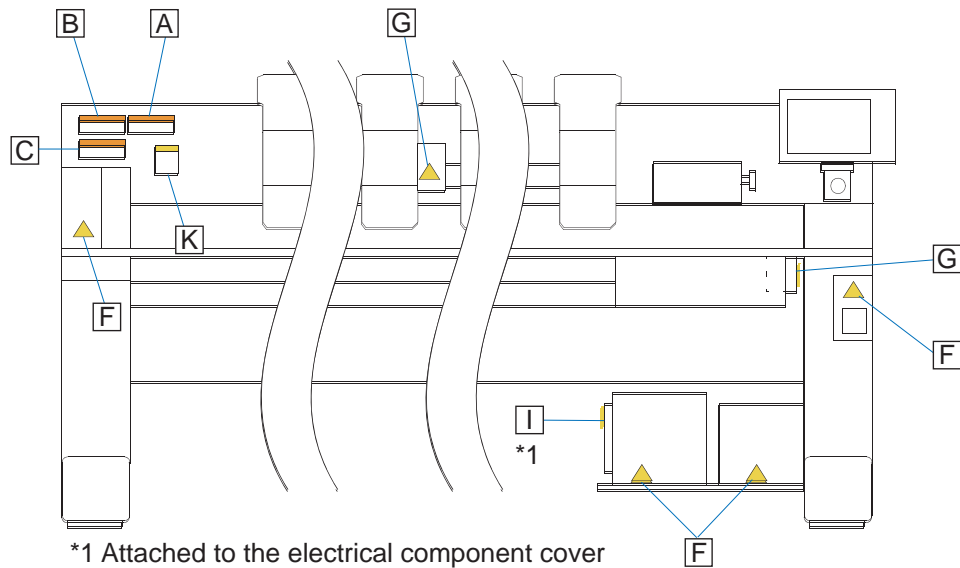

TMEZ-SC

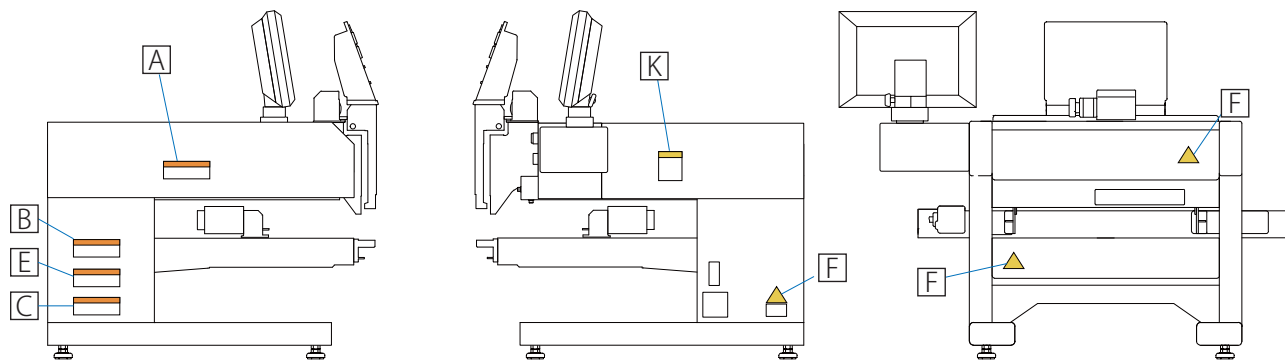

Chapter 3

Safety Device

To ensure safety, the machine is equipped with the following safety devices.

1. Emergency Stop Switch

The emergency stop switch is located on the front side of the machine.

Press the emergency stop switch when you must immediately stop the machine to avoid an accident or other danger.

⚠ Caution

- ❗ Make sure of the location of the emergency stop switch when you use the machine for the first time.
- ⊘ Do not use the emergency stop switch instead of the normal power switch.



- The machine may have two or more emergency stop switches in different locations, depending on the model and spec. An additional emergency stop switch may be located on the rear side of the machine.
- The emergency stop switch appearance may differ depending on the model.

1-1. Emergency stop switch locations

■ TMCR-VF, TMCP-VF

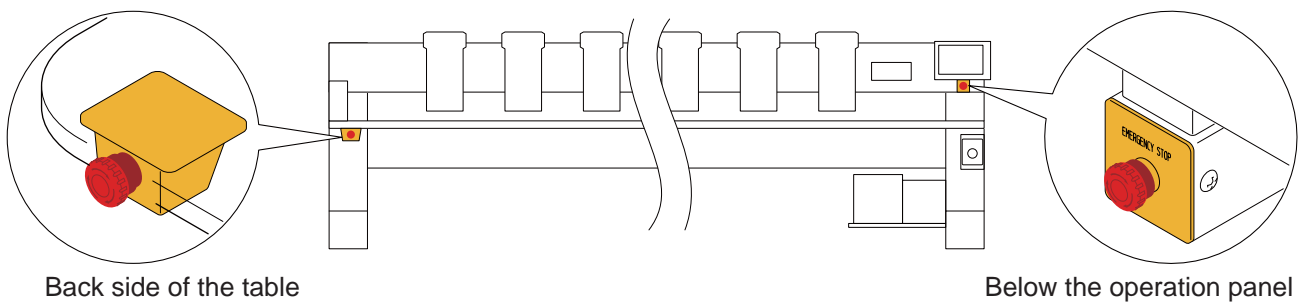

■ TMEZ-SC

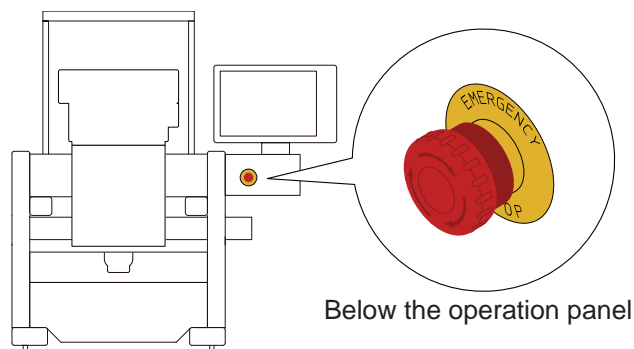

1-2. Operating the emergency stop switch

■ TMCR-VF, TMCP-VF

Pressing the emergency stop switch immediately stops the machine, and the switch is locked in the depressed position. The power switch is set to the middle position between ON and OFF.

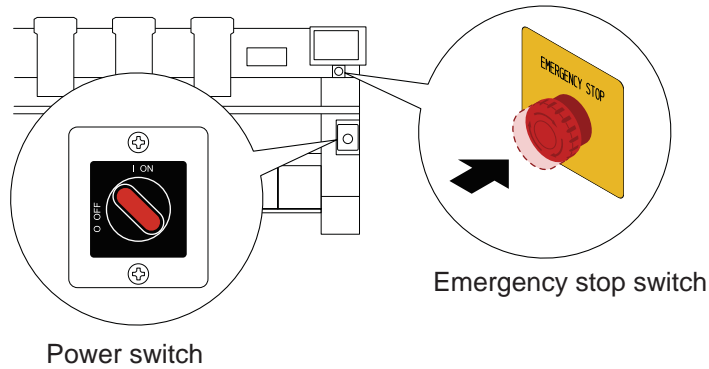

■ TMEZ-SC

Pressing the emergency stop switch immediately stops the machine, and the switch is locked in the depressed position. The power switch is turned OFF.

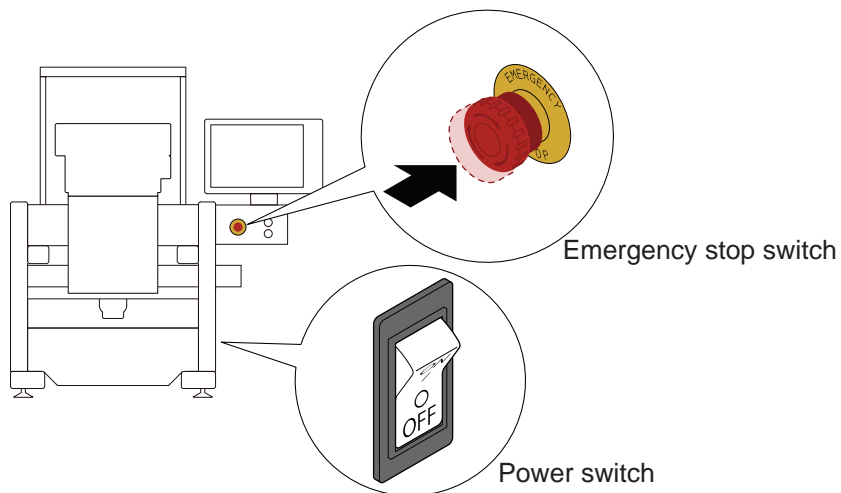

1-3. Resetting the emergency stop switch

The resetting method differs depending on the model and spec.

⚠ Caution

- ❗ Ensure safety before resetting the emergency stop switch.
- ❗ Before you turn ON the power again, wait for 30 seconds or more. Otherwise the system may fail to start up normally.
- 🚫 Do not put your hands or anything else on the table when you turn ON the power. Failure to observe this may result in injury due to contact with the frame.

■ TMCR-VF, TMCP-VF

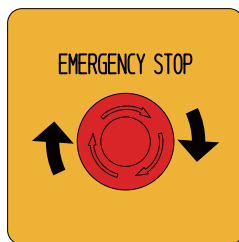

- 1 Turn the emergency stop switch clockwise. It is unlocked.

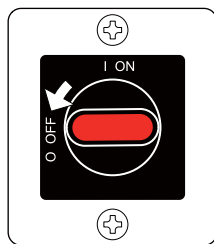

- 2 Set the power switch from the intermediate position to the OFF position.

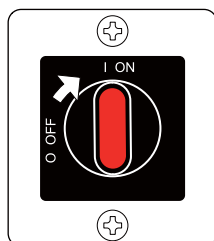

- 3 Before you turn ON the power switch, wait for 30 seconds or more. The system starts up. The message screen appears if you press the emergency stop switch while the machine is running.



- The main screen appears if you press the emergency stop switch while the machine is stopping.

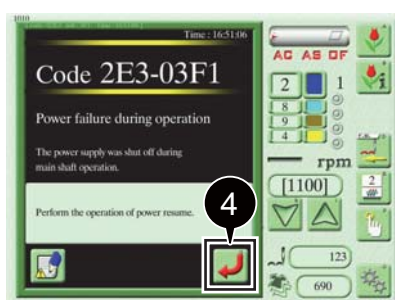

- 4 Press  on the message screen. The power resume method selection screen appears.



5 Select the power resume method.



:Perform power resume after trimming the thread.



:Perform power resume without trimming the thread.



- When the power is resumed, the machine checks the absolute origin and the frame moves to a position several stitches back from the position where it was when the power was turned OFF.

TMEZ-SC



1 Turn the emergency stop switch clockwise. It is unlocked.



2 Before you turn ON the power switch, wait for 30 seconds or more.

The system starts up.

The message screen appears if you press the emergency stop switch while the machine is running.



- The main screen appears if you press the emergency stop switch while the machine is stopping.

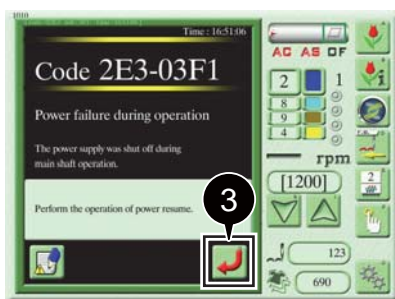

3 Press  on the message screen.

The power resume method selection screen appears.

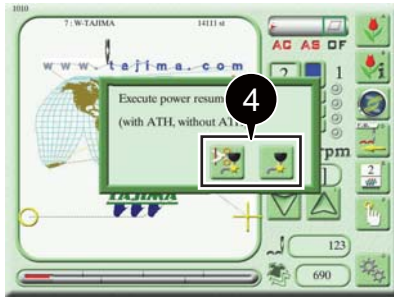

4 Select the power resume method.



:Perform power resume after trimming the thread.



:Perform power resume without trimming the thread.



- When the power is resumed, the machine checks the absolute origin and the frame moves to a position several stitches back from the position where it was when the power was turned OFF.

Basic Operation

This manual describes the basic procedures for operating the machine, performing embroidery, and performing maintenance.

Chapter 1	Basic Operation of the Machine	28
Chapter 2	How to Embroider	42
Chapter 3	i-TM	62
Chapter 4	Manual Operation	80
Chapter 5	Deleting or Saving Designs	96
Chapter 6	Maintenance	105
Chapter 7	Troubleshooting	120
Chapter 8	Appendix	129

Chapter 1

Basic Operation of the Machine

1. Turning ON/OFF the Power

The power switch is located on the right side of the machine.

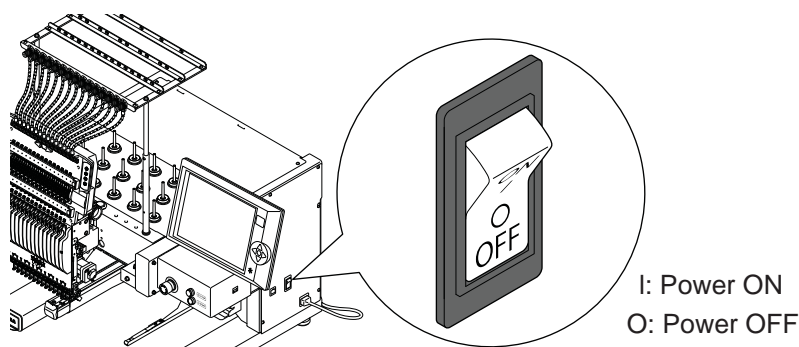

1-1. Turn ON the power

⚠ Caution

- ! To turn ON the power again, wait for 30 seconds or more. Otherwise the system may fail to start up normally.
- ⊘ Do not turn ON the power with the USB memory connected to the operation panel. Otherwise the system may fail to start up normally.



- 1 Turn ON the power.
Once the power is turned ON, the system starts up and the software version screen appears.
The tension base multi-color LEDs (left and right) are lit in light blue while the system is starting up.

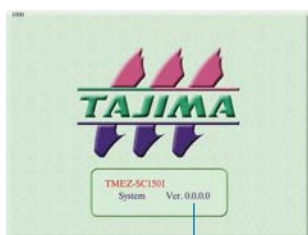

Software version

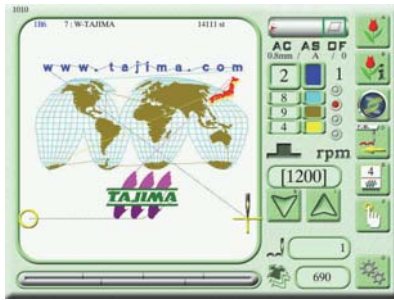

Once the system starts up, the main screen appears. In addition, the tension base multi-color LED (right) lights up in green.



- The color and lighting status of the multi-color LEDs after system start-up differ depending on the status before turning OFF the power. For details, refer to "Chapter 1 3. Multi-color LEDs".

1-2. Turn OFF the power

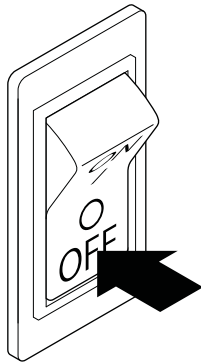

1 Turn OFF the power.



- Unless in an emergency, do not turn OFF the power by pressing the emergency stop switch.

2. Start and Stop of the Machine

To start and stop the machine, use the start/stop switch located on the front face of the machine.

2-1. Start the machine

⚠ Caution

! Before starting the machine, pay enough attention to the surrounding safety. You may be injured by a moving needle bar or frame.

[To start the machine immediately]

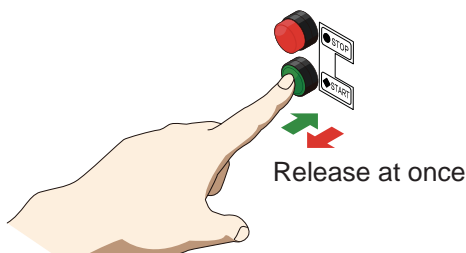

Press the start switch and release it immediately. The needle bar moves up and down slowly (in an inching manner) and then the machine starts operation.



- You can configure the number of inching times (during startup) with a parameter. For details, refer to the separate "Parameter Settings" manual.

[To start the machine gradually]



Press the start switch and hold it in that position. While you are holding it, the needle bar moves up and down slowly (in an inching manner).



- When you release the start switch, the machine starts normal embroidery operation.

2-2. Stop the machine

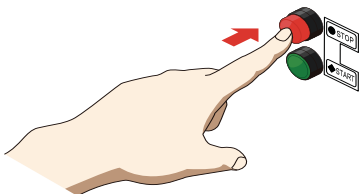

Press the stop switch. The machine stops operation.







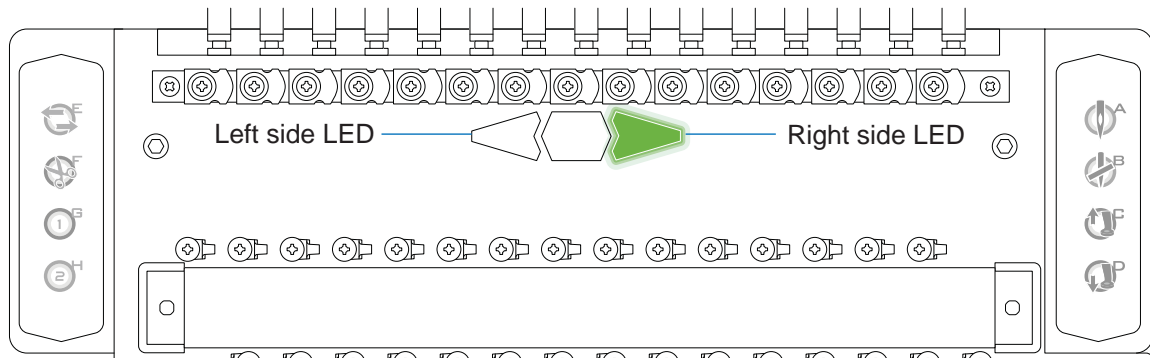

- You can use the start/stop switch, not only to start and stop the machine, but also to move the frame along the stitches for repair stitching at thread breakage (Frame Back/Frame Forward). For details, refer to "Chapter 4 1. Moving Back or Moving Forward the Frame along the Stitches".

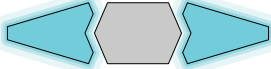
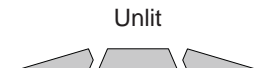
3. Multi-color LEDs

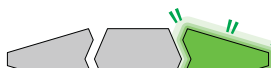
The tension base multi-color LEDs light up or blink in a particular color to indicate the machine operation status or the occurrence of thread breakage.







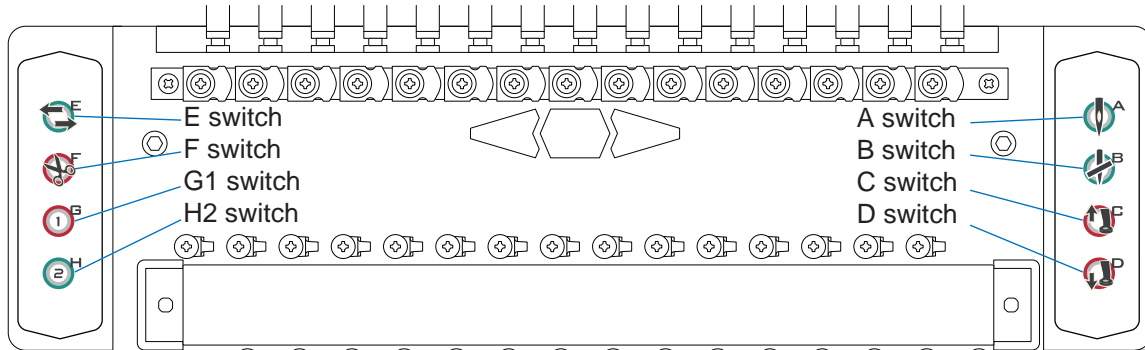

LED	Color	Condition
Right/left	Lit in light blue 	The both LEDs are lit during start-up until the main screen appears.
	Unlit 	The both LEDs go off when the head is suspended.
Right side	Lit in green 	Lit when embroidery is available or in progress.
	Blinking in green 	During Frame Back (i.e., while moving back the frame along the stitches), the LED blinks if the head is one without thread breakage.
	Lit in red 	Lights up if the upper thread is broken.
	Blinking in red 	Blinks if the under thread is broken.
	Lit in orange 	Lights up if the start method of sewing after Frame Back is set to "return stitching" and "repair stitching". * 1
Left side	Lit in blue 	If you stop the machine during embroidery and manually move the frame, this LED lights up to indicate that the frame is not at the original position (i.e., the position where it was when you stopped the machine).

*1: To change the start method of sewing after Frame Back, use the A switch on the tension base. For details, refer to "Chapter 1 4. Direct Command Switch".



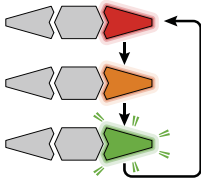

4. Direct Command Switch

The following functions are assigned to the direct command switches on the left and right sides of the tension base.



Switch	Function
<p>A switch</p> 	<p>Changes the head to "active".</p> <p>The multi-color LED lighting color switches as follows every time you press the A switch after you have performed Frame Back by the thread breakage. * 1</p>  <p>Red: The machine performs repair stitching.</p> <p>Orange: The machine performs return stitching and repair stitching.</p> <p>Blinking in green: The machine does not perform repair stitching.</p>
<p>B switch</p> 	<p>Changes the head to "suspended".</p> <p>For the suspended head, the multi-color LEDs go off and the needle bar will not move up/down even if you start the machine.</p>
<p>C switch</p> 	<p>Hold down this switch (for 1 second) to move up the needle bar.</p>
<p>D switch</p> 	<p>Hold down this switch (for 1 second) to move down the needle bar.</p>
<p>E switch</p> 	<p>Toggles between Frame Back and Frame Forward.</p>

*1: Even when you are not performing Frame Back, the multi-color LED lighting color changes every time you press the A switch.

Switch	Function
F switch 	Hold down this switch (for 1 second) to trim the upper and under threads.
G1 switch 	<p>You can assign one of the functions shown below to the G1 switch, by the parameter settings.</p> <p> Pressing G1 switch longer cause the warning buzzer to sound, and operate the selected function.</p> <ul style="list-style-type: none"> This function can be operated only when the machine is stopped at the main shaft fixed position and the main screen is displayed. The head where LED at the tension base is unlit do not function. <ul style="list-style-type: none"> Trace (High speed) Trace (Low speed) Offset return Manual offset Frame travel to an optional position Return to the start position Raising of needle bar Manual thread trimming (under thread only) 1 stitch dropping ^{*1} Lower needle bar to lower dead point (stop at the lower dead point) ^{*2}
H2 switch 	<p>You can assign one of the functions shown below to the H2 switch, by the parameter settings.</p> <p> Pressing H2 switch will cause the warning buzzer to sound, reset the setting of preset halt, or turn ON/OFF the light.</p> <ul style="list-style-type: none"> This function can be operated only when the machine is stopped and main screen is displayed. The head where LED at the tension base is unlit do not function. <ul style="list-style-type: none"> Reset of Preset Halt (Stitch) ^{*3} Reset of Preset Halt (Data) ^{*3} Reset of Preset Halt (Design) ^{*3} LED light ON/OFF Thread trimming at the time of repair stitches <p>If equipped with a sequin device, you can use this switch to feed sequin chips.</p>

*1: If G1 switch is pressed longer, the needle bar is lowered by 1 stitch.

If the multi-color right LED is blinking in green (not at the time of repair stitching), "1 stitch dropping" cannot be operated.

*2: When raising the needle bar, operate by the operation panel.

*3: When you stop this machine during embroidery and press the H2 switch, the preset halt value will be reset and the value of the parameter "6 Total Stitch Counter" will be cleared.

5. Screen Operations

Use the operation panel to perform operations for embroidery and configure various settings.

The touch panel allows you to switch the display screen and configure various settings by lightly touching the icons displayed on the screen.

⚠ Caution

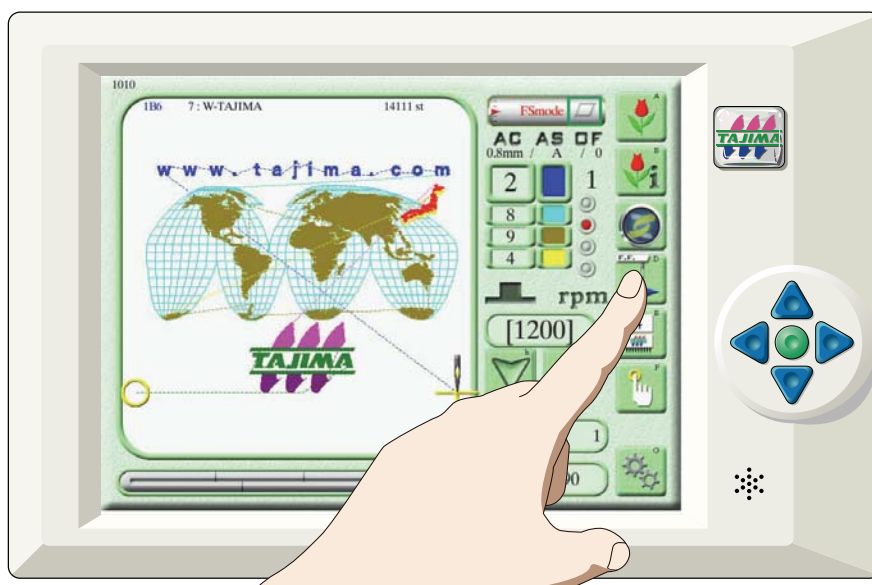

- ! Touch them with your finger.
- ⊘ Do not forcibly press the touch panel or apply something sharp to it because doing so may break the panel.

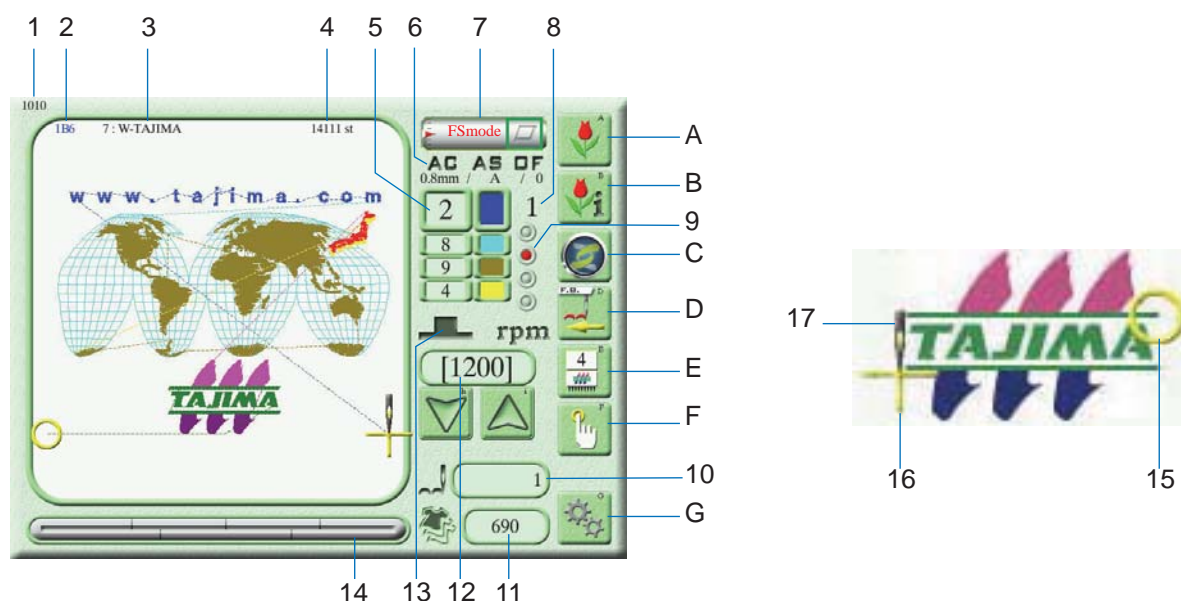

5-1. Main screen

The main screen appears once you turn ON the power and the system successfully starts up. You can begin to configure various settings and operate the machine from the main screen.



No.	Description	No.	Description
1	Screen number	13	Current main shaft angle 
2	Stop factor (displayed during stop of the machine)	14	Embroidery progress (indicated by red scale marks)
3	Design name	15	Embroidery end point
4	Total number of stitches of design	16	Embroidery start point
5	Needle bar No. of the current step	17	Current embroidery position
6	AC (Auto Color Change), AS (Auto Start), and OF (Automatic Offset) setting status (displayed in red if the setting is enabled)	A	Navigate to the design selection screen
7	FS mode setting status ("FS mode" is displayed if enabled)	B	Navigate to the detailed information screen of design
8	Current needle bar step No.	C	i-TM mode display  : Auto mode  : Manual mode Navigate to the detailed information screen while in manual mode.
9	Setting status of offsetting at automatic color change (displayed in red if enabled)	D	Navigate to the current FB (Frame Back)/FF (Frame Forward) setting condition and FB/FF screens
10	Current number of stitches	E	Navigate to the manual color change screen (the displayed number is the current needle bar No.)
11	Cumulative embroidery count (even if the power is turned OFF/ON, counting will continue.)	F	Navigate to the manual operation screen
12	Maximum speed (Maximum RPM)	G	Navigate to the parameter setting screen

5-2. Design selection screen

This screen lets you save, select, or edit your design.

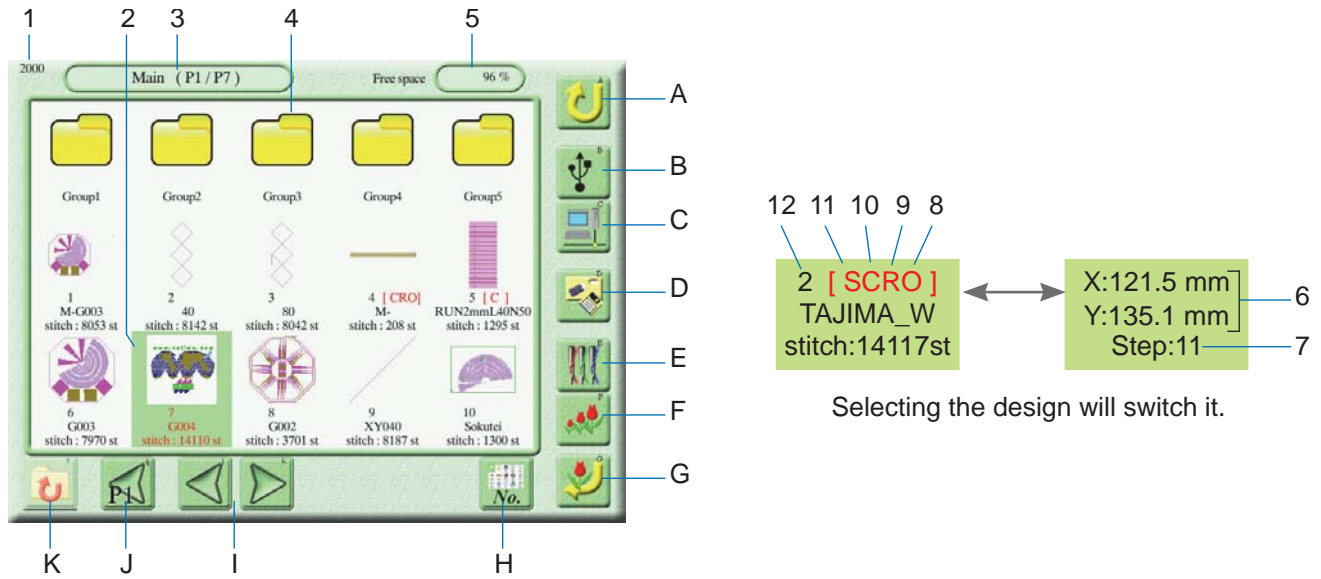

No.	Description	No.	Description
1	Screen number	A	Back (return to the previous screen)
2	Design stored in the machine memory	B	Navigate to the USB memory screen
3	Screen page	C	LAN cable connected
4	Design storage folder (You cannot change the folder names "Group1" to "Group5")	D	Navigate to the design edit screen
5	Machine memory capacity (40,000,000 stitches) (Free space percentage (%) is displayed. The remaining number of stitches is displayed instead if the free space is 20% or lower.)	E	Navigate to the needle bar selection screen
6	Design size	F	Navigate to the design enlargement/reduction and repeat screens
7	Number of needle bar steps	G	Save Changes (navigate to the data set screen)
8	With setting of automatic offset	H	Rearrangement of designs (Designs are reordered every time you touch the icon.) • No.: In the ascending order of machine memory numbers • Name: Alphabetical design name order • Time: Updating order
9	With setting of repeat		
10	With setting of scaling up/down of design	I	Navigate to the previous or next page
11	Indicates that the embroidery condition for the needle bar step has been changed	J	Back (return to the first page)
12	Machine memory No. (When you store a design in the machine memory, the next available machine memory No. is assigned)	K	Back (return to the "Main" folder screen if the "Group" folder is selected)



- The icon C is not displayed if a LAN cable is not connected.
- When there is no design in the machine memory, the icons D, E, and F are not displayed.

5-3. Description of basic icons

There are common icons you can use to switch the display screen, save settings, or enter alphanumeric characters.

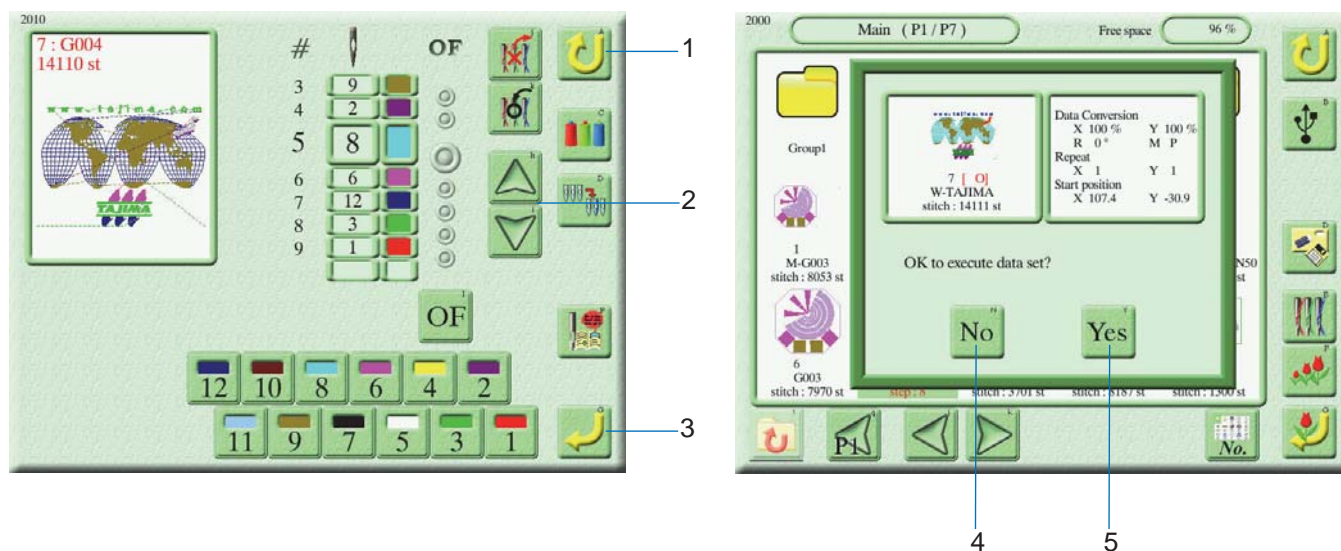

Common icons

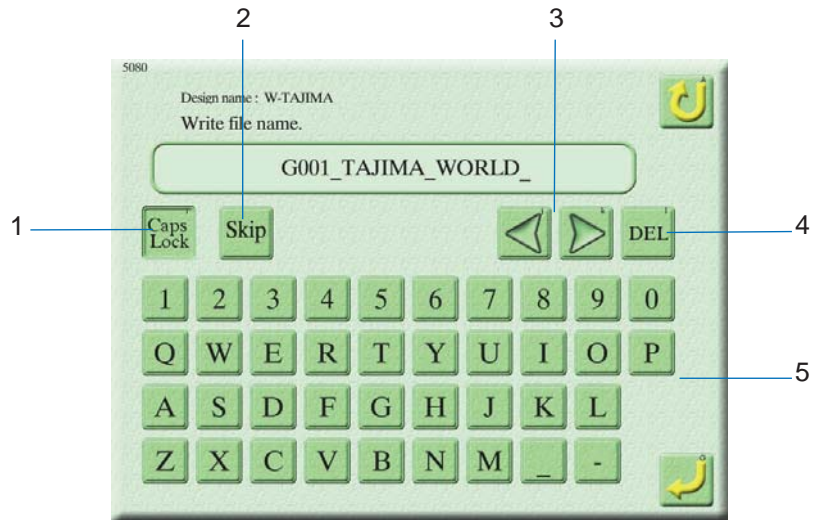

No.	Description
1	The screen will return to the previous screen by one.
2	Increase/decrease the value or scroll up/down the screen.
3	Put the setting into effect.
4	Cancel the operation and disable the setting.
5	Save or enable the setting.

■ Entering alphanumeric characters



No.	Description
1	Toggle between uppercase and lowercase.
2	<p> : If there is a design with the same name in USB memory, it will be overwritten and saved.</p> <p> : If there is a design with the same name in USB memory, the new design will be saved under the file name appended with (1) at the end.</p>
3	Move the cursor.
4	Delete the character at the cursor position.
5	Enter a character by pressing the corresponding icon.

6. Travel of Frame

To manually move the frame, use the frame travel keys on the operation panel.

To change the frame travel speed, use the speed switching key.

6-1. How to move the frame

While you are holding down one of the frame travel keys, the frame keeps moving in that direction.

⚠ Caution

- Do not put your hand on the table or bring your hand close to the frame because doing so may cause your finger or hand to be injured when the frame moves.

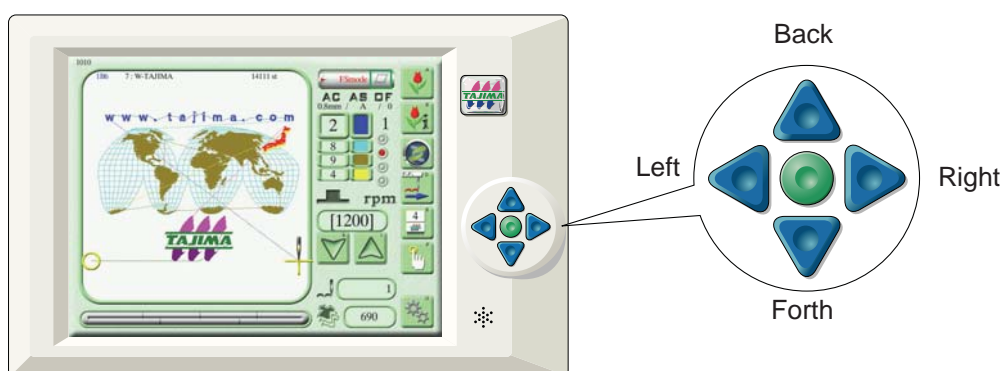

- A message screen appears when the frame reaches the limit of the embroidery space. Press the icon (return) to move the frame into the embroidery space.
- If you have moved the frame by hand with the power OFF, turn ON the power and execute absolute origin search. For more information on absolute origin search, refer to "Chapter 4 4-6. Absolute origin search".

6-2. Changing the travel speed

You can toggle between the low and middle frame travel speeds by pressing the speed switching key.

Also, you can move the frame at high speed by pressing one of the frame travel keys while holding down the speed switching key.

Low speed	Middle speed	High speed
Press the speed switching key to turn off its back light, then press one of the frame travel keys. Speed switching key Unlit	Press the speed switching key to turn on its back light, then press one of the frame travel keys. Lit	Press one of the frame travel keys while holding down the speed switching key.

6-3. Checking the frame position (coordinates)

You can check the current frame position (coordinates) on the manual operation screen.



- To display the manual operation screen, press  on the main screen.

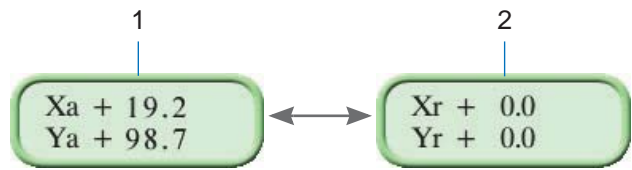
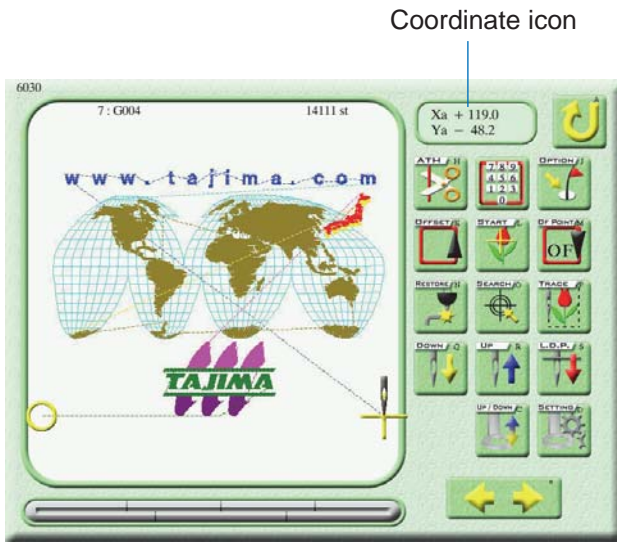

Pressing the coordinate icon will change the indication.

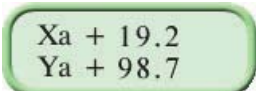
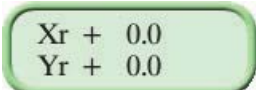
No.	Coordinate icon	Description
1		The coordinates based on the absolute origin of the frame appear.
2		The coordinates based on the start position of the design whose data is set appear.



- If the coordinates are not correctly displayed, the absolute origin may not be correctly set. Execute absolute origin search. For more information on absolute origin search, refer to "Chapter 4 4-6. Absolute origin search".

7. Data Input/Output

The machine is equipped with a USB port on the right side of the operation panel and a LAN port on the right side of the machine.

7-1. Connecting a USB memory

Insert a USB memory into the USB port on the operation panel. You can use a USB memory to input/output designs and upgrade the software version.

⚠ Caution

- ⊘ Do not turn ON the machine power with a USB memory inserted into the operation panel. Otherwise the system may fail to start up normally.
- ⊘ Do not insert a USB memory if it contains dirt or dust inside the connector.
- ⊘ Do not insert or remove a USB memory while the machine is running.
- ⊘ Do not forcibly insert a USB memory.
- ⓘ Insert a USB memory slowly.
- ⓘ Insert a USB memory straight into the USB port. Diagonally inserting a USB memory may cause the connector to interfere with and possibly destroy the internal circuit board.
- ⊘ Do not attempt to use a USB memory until at least five seconds elapse after you insert it.

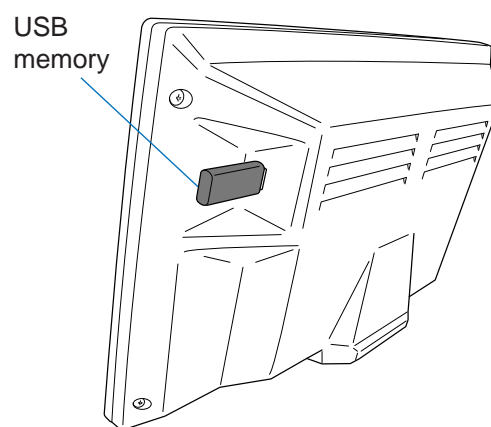

- The machine does not work with USB memories of certain types and capacities.
- Use a recommended USB memory (i.e., a USB 2.0-compliant USB memory formatted in the FAT/FAT32 format).

7-2. Connecting a LAN cable

Connect a LAN cable to the LAN port on the right side of the machine. Use the LAN cable to connect the machine to your PC via LAN.

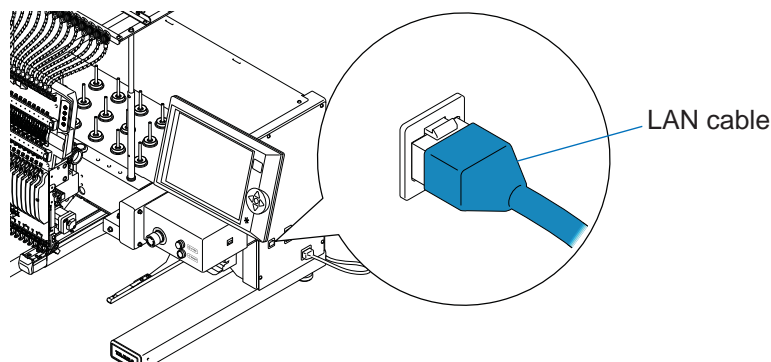

- To connect the machine via a router to your PC, use a straight cable available on the market.
- To directly connect the machine to your PC, use a cross cable available on the market.
- For more information on connecting the machine to your PC, refer to the separate "Advanced Operation" manual.

Chapter 2

How to Embroider

1. Basic Flow of Embroidery

For details, refer to the corresponding guides and chapters.

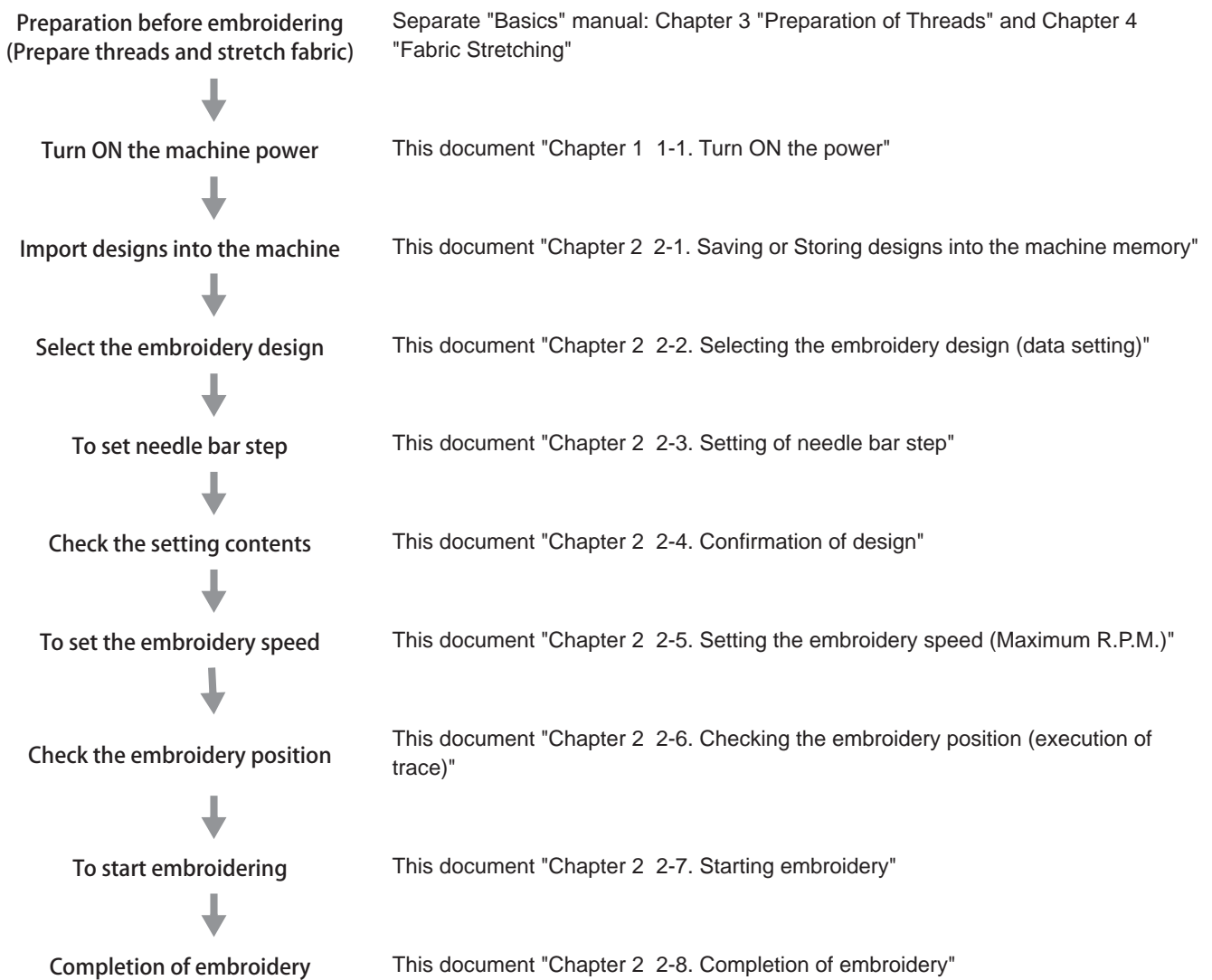

2. Embroidery Procedures

This section describes the procedures for importing the desired designs into the machine memory and starting and completing embroidery.

2-1. Saving or Storing designs into the machine memory

Save the embroidery design in the machine memory by one of the following methods:

- A USB memory
- Your PC
- A bar code reader

The following example shows how to select two designs from a USB memory and store them in the "Main" folder in the machine memory.



- The "Main" folder can store up to 200 designs and the folders from "Group1" to "Group5" can each store up to 90 designs (thus up to 650 designs in all). The maximum number of designs you can store may, however, be smaller than mentioned above depending on the free space of the machine memory.
- A design that has been embroidered contains the color change sequence and start position (condition data). When you store a design, its condition data will also be stored in the machine memory.
- The machine memory can store designs from your PC and bar code reader as well. For details, refer to the separate "Advanced Operation" manual.

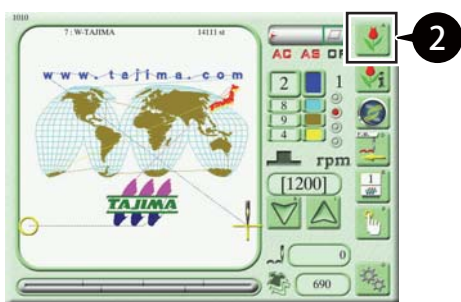

1 Insert a USB memory containing designs into the USB port on the operation panel.

2 Press  on the main screen.

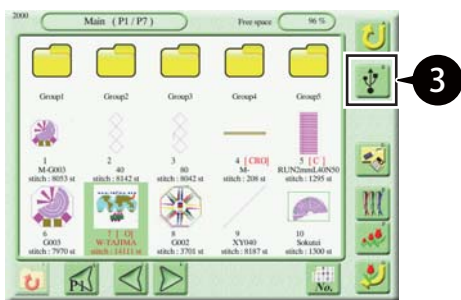

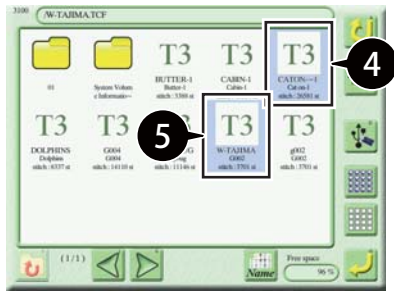

3 Press .



4 Select the first desired design.



- Press  to select all the designs.
- Press  to deselect all the designs.

5 Select the second desired design.



6 Press .



- If the maximum number of designs you can store is exceeded or the machine memory is short of free space, code No.2BA appears.

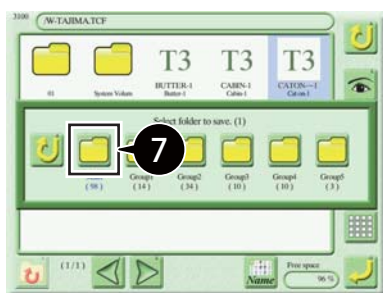

7 Press  "Main".

The selected designs are stored into the machine memory.

About the display of a design

In the USB memory, a design is displayed as follows:

- T** ← Saving format of design
- G0003** ← File name (indicated on your PC)
- MADELENE** ← Design name
- stitch:30034st** ← Number of stitches of design

Saving format of design

- T: TAJIMA format (DST)
- T2: TAJIMA binary format (TBF)
- T3: TAJIMA integrated file (TCF)

Depending on saving format of the design, the design except above one will be displayed.

2-2. Selecting the embroidery design (data setting)

Select the embroidery design so that the machine can start embroidery.

⚠ Caution

- ⊘ Do not put your hands on the table when you operate the machine because doing so may cause your finger or hand to be injured when the frame moves.

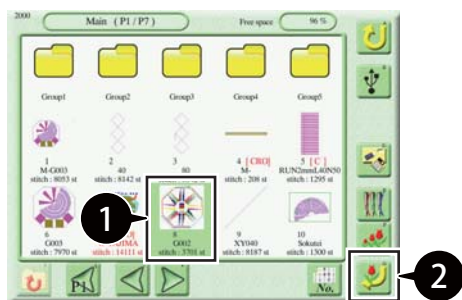

- 1 Select the embroidery design on the design selection screen.

- 2 Press .

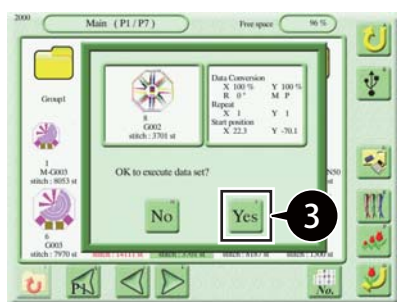

- 3 Press .

The design data is set.

[If the design contains the start and offset positions]

If the design contains the "start position" (i.e., the previous embroidery start position of the selected design) and "offset position", the frame travel message screen appears after the data is set.

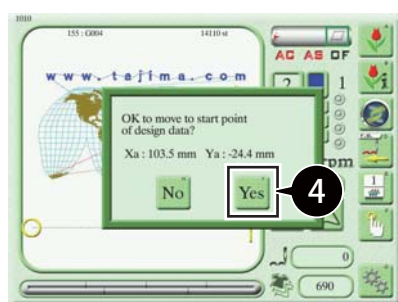

- 4 Press .

The frame moves to the start position or the offset position.

If you select "No", the current frame position will be the design start position.



- For more information on Automatic Offset settings, refer to the separate "Advanced Operation" manual.

[If the design contains a message]

If the design contains a message created with DG by Pulse (optional design creation software), the message will appear after you set the data and upon completion of embroidery. For more information, refer to the user's manual for DG by Pulse.

Example: After you set the data

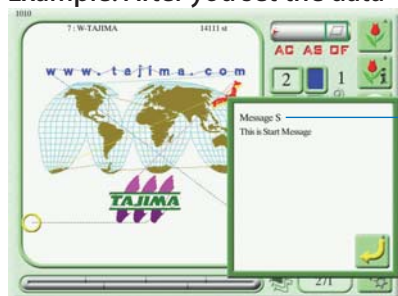

Message S



- Writing a message into the design data (****.TCF) requires DG15 by Pulse or later.

2-3. Setting of needle bar step

Set a needle bar to use (sewing order) for each needle bar step of the selected design.

The machine performs embroidery while automatically changing the color based on those settings.

The following example shows how to assign the needle bar No. 4 to the needle bar step 1 and the needle bar No. 6 to the needle bar step 2.



- If the "Auto Color Change" parameter is set to "No", the machine will not automatically change the color. For details, refer to the separate "Parameter Settings" manual.
- This procedure is not required when the color change sequence is included as the condition data in the design.

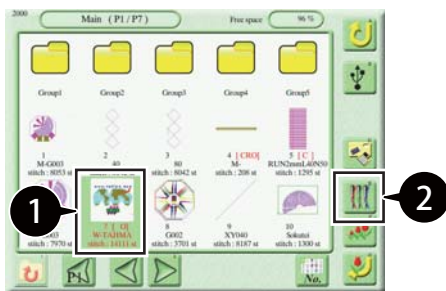

1 Select the desired design on the design selection screen.

2 Press .

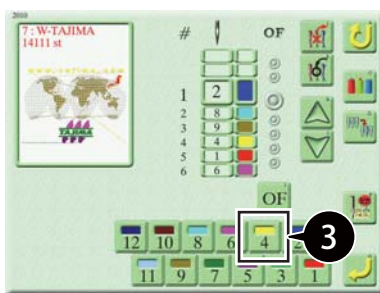

3 Press .

Needle bar No. 4 is assigned to the needle bar step 1 and the screen proceeds to the next needle bar step.



- To select an arbitrary needle bar step,

press  .

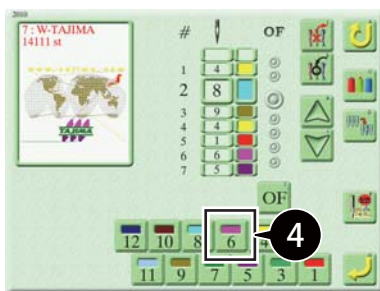

4 Press .

Needle bar No. 6 is assigned to the needle bar step 2 and the screen proceeds to the next needle bar step.

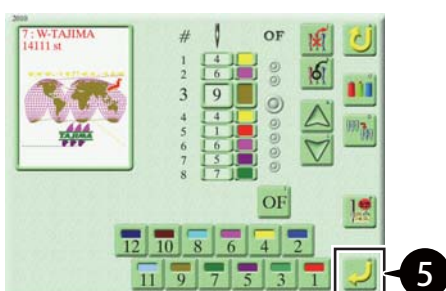

5 Press .

Now you are done configuring the needle bar steps.

2-4. Confirmation of design

You can check the size and orientation of the design whose data is set and other settings.

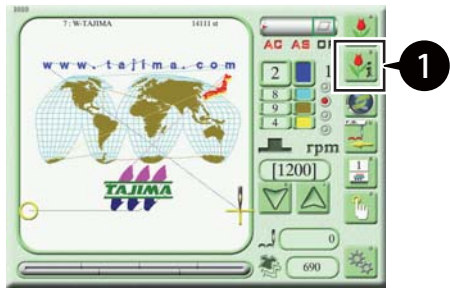

1 Press .

2 To check the settings, use the following confirmation screen.

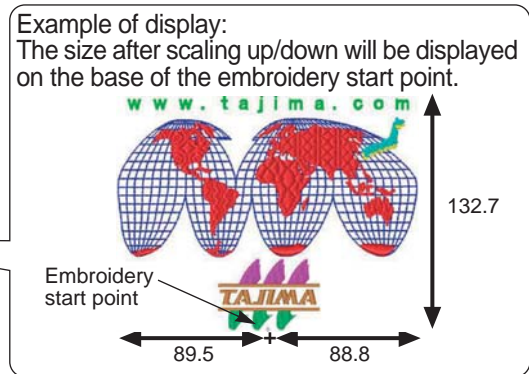
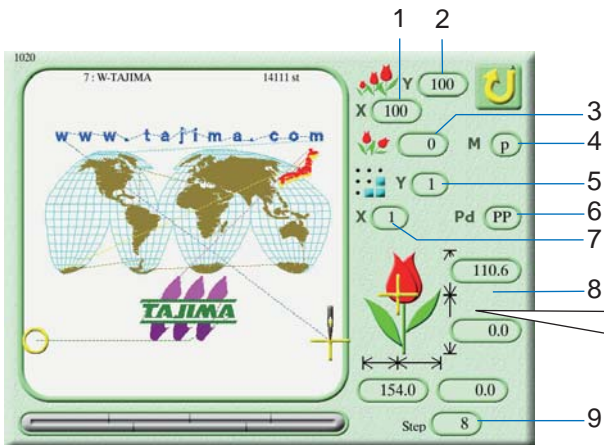

No.	Description	No.	Description
1	Scale ratio of design (Horizontal)	6	Design repeat pattern
2	Scale ratio of design (Vertical)	7	Number of repeats of design (Horizontal)
3	Rotating angle of design	8	Size of design (mm)
4	Reversion of design (p = do not reverse, q = reverse)	9	Number of needle bar steps of design
5	Number of repeats of design (Vertical)		





• For more information on the settings, refer to the separate "Advanced Operation" manual.

2-5. Setting the embroidery speed (Maximum R.P.M.)

You can set the maximum embroidery speed (Maximum R.P.M.).

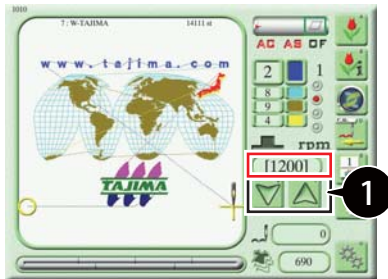

During operation, the embroidery speed changes according to the stitch length of the design without exceeding the configured maximum speed.



1 Press   to set the maximum speed.

The new setting appears in the red box.



- Hold down   to change the value continuously.
- You can configure the setting in the middle of embroidery.

2-6. Checking the embroidery position (execution of trace)

Before starting embroidery, you can move the frame along the contour of the design (as referred to as "tracing") to check if the embroidery position (start position) is correct and check if the design will fall within the embroidery space.

■ Outline of trace

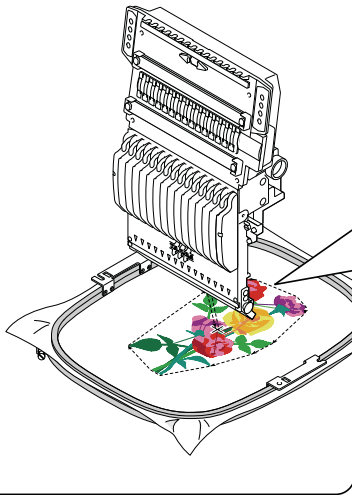

Tracing starts at the start position and proceeds along the contour of the design.

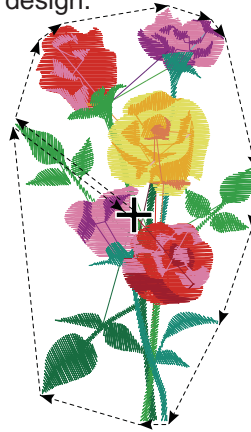

⊕ : Start position

[If Automatic Offset setting is enabled for the frame]

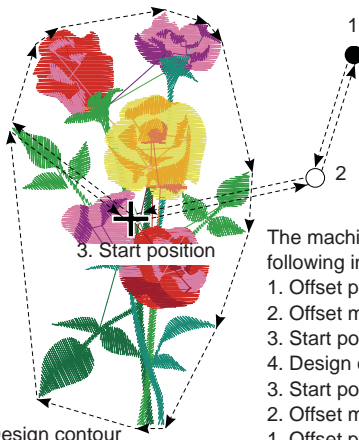

The machine will trace the following in this order:
 1. Offset position
 2. Offset middle position
 3. Start position
 4. Design contour
 3. Start position
 2. Offset middle position
 1. Offset position

[If the repetition setting is enabled for the design]

The machine will trace whole designs after tracing the first design.

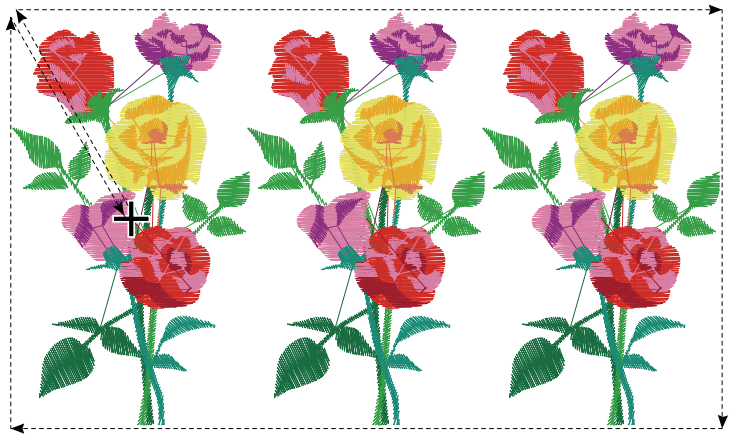

- For more information on Automatic Offset settings, refer to the separate "Advanced Operation" manual.
- For more information on repetition settings, refer to the separate "Advanced Operation" manual.
- If the start position is not correct, the frame stops tracing and error No.225 appears.
Correct the start position and perform tracing again.

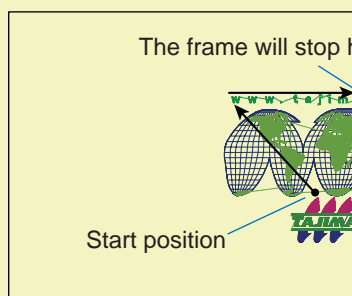

It is not possible to embroider this part.

How to operate

⚠ Caution

- Do not put your hands on the table when you operate the machine because doing so may cause your finger or hand to be injured when the frame moves.

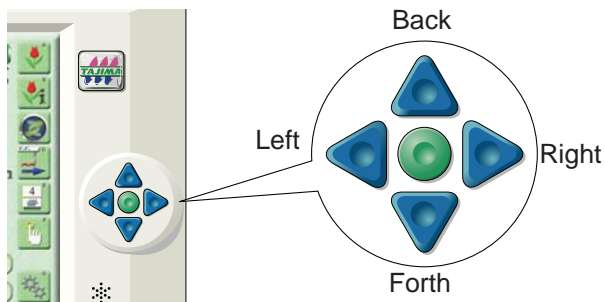

- Using the frame travel key, move the frame to the start position.



- For more information on moving the frame, refer to "Chapter 1 6-1. How to move the frame".

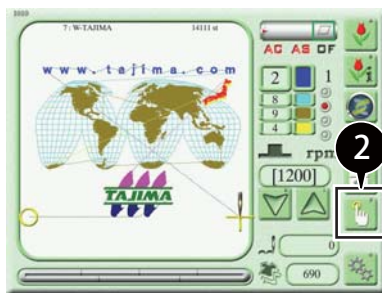

- Press  on the main screen.

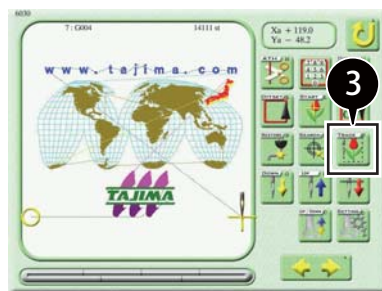

- Press .



- Execute Tracing.



: High speed frame travel



: Low speed frame travel



- The position where tracing was executed is stored as the start position.
- To suspend tracing, stop the machine. To resume tracing, follow instructions on the screen.



3 : Current needle bar No.

2-7. Starting embroidery

⚠ Caution

! Before starting embroidery, pay enough attention to the surrounding safety. You may be injured by a moving needle bar or frame.

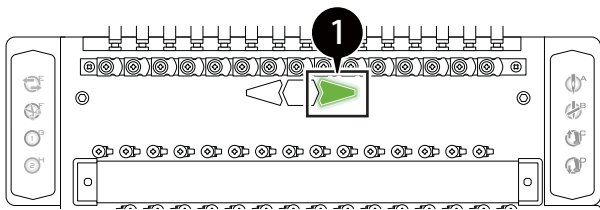

1 Check that the multi-color LED (on the right side) of the embroidery head is lit in green.



- If it is not lit, press the A switch on the tension base.

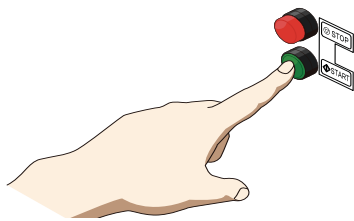

2 Press the start switch.

The needle bar moves up and down slowly (in an inching manner) and then embroidery starts.



- For more information on operating the start/stop switch, refer to "Chapter 1 2-1. Start the machine".

■ Checking the progress of embroidery

The progress of embroidery is indicated by red scale marks in the lower part of the main screen.

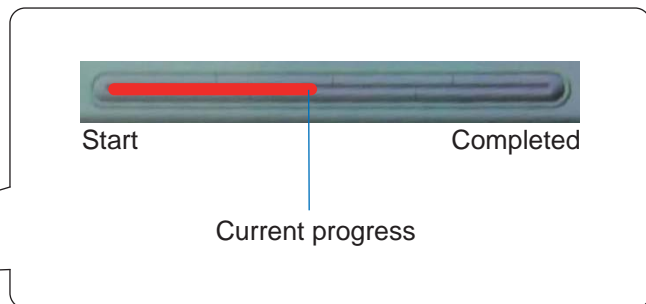
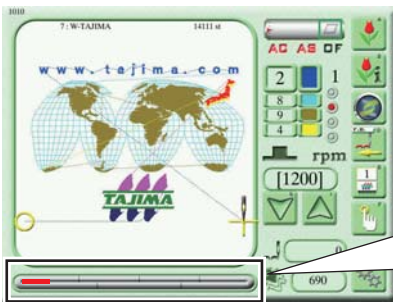

■ How to resume embroidery after moving the frame

After you manually move the frame during embroidery, you can resume embroidery by one of the following methods:

- Return the frame to the original position using manual offset operations and then resume embroidery using the start switch.
- Resume embroidery by pressing the start switch. (This method is only available if the "Return the frame after manual frame travel" parameter is set to "Yes".)



- For more information on manual offset, refer to "Chapter 4 4-2. Moving the frame to the original position (manual offset)".
- If the "Return the frame after manual frame travel" parameter is set to "No", the frame does not return to the original position and embroidery resumes from the position the frame moved to. The parameter is set to "No" by factory default. For details, refer to the separate "Parameter Settings" manual.

2-8. Completion of embroidery

Upon completion of embroidery, the frame moves to the start position and the machine stops operation.

Caution

-  Do not put your hands on the table when embroidery is completed because doing so may cause your finger or hand to be injured when the frame moves.



- If the "Automatic origin return" parameter is set to "Yes", the frame moves to the design start position upon completion of embroidery. If it is set to "No", the frame stops at the same position as when embroidery is completed. For details, refer to the separate "Parameter Settings" manual.

The frame moves to the start position

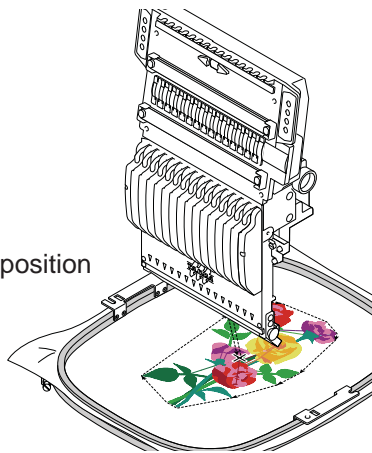

[If Automatic Offset setting is enabled for the frame]

Upon completion of embroidery, the frame moves to the offset position and the machine stops operation.



- For more information on Automatic Offset settings, refer to the separate "Advanced Operation" manual.

The frame moves to the offset position

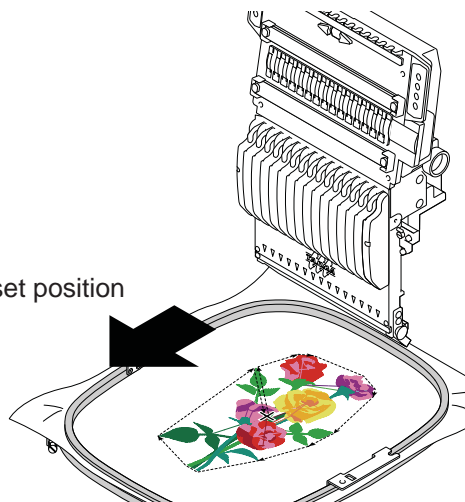

3. Making Use of DCP

The Digitally Controlled Presser Foot (DCP) is a function that uses a motor and digitally controls the presser foot to press the fabric.

It is possible to set the height and stroke of the presser foot according to the type and thickness of the fabric, which reduces the rattling of the fabric and achieves more stable sewing.

In addition, by using the touch panel, the DCP allows ease of presser foot adjustments, which operators needed to make manually.

3-1. Setting items for presser foot

Although presser foot settings are made with parameters in advance, you can change the following settings according to the type and thickness of the fabric.



- The function settings are not operable while in "Auto mode". Use the parameter "i-TM mode" and set to "Manual mode".

■ Settings for presser foot lower dead point

Set the height from the needle plate to the presser foot lower dead point.

Make settings with consideration of the thickness of the fabric.

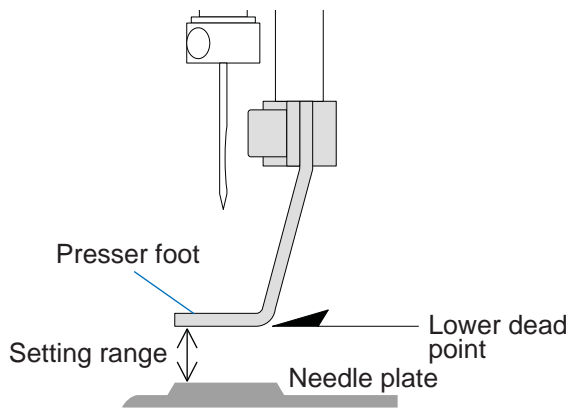

⚠ Caution

- Do not set the value lower than the thickness of the fabric. Doing so may cause the presser foot to come in contact with a part where the fabric is piled up and raised, and the machine may be damaged.

Setting range: 0.3 to 6.3 mm

■ Settings for presser foot stroke

Set the presser foot stroke.

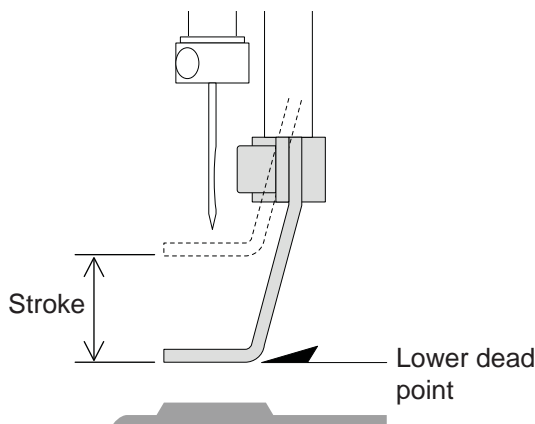

- If the stroke becomes larger, sewing mistakes can occur easily. Set the value by checking the sewing condition.

Setting range: Functional limit level 1: 5.0 to 22.0 mm

Functional limit level 2, SEL: 2.0 to 22.0 mm

■ Settings for presser foot timing

Set timing when the presser foot starts to move down.

The smaller the setting value, the faster the moving down timing of presser foot. The larger setting value causes the delay of the timing.

The mutual relation among the lower dead point, the stroke, setting range of timing of the presser foot and the locus of the needle is shown roughly in the figure as reference information.

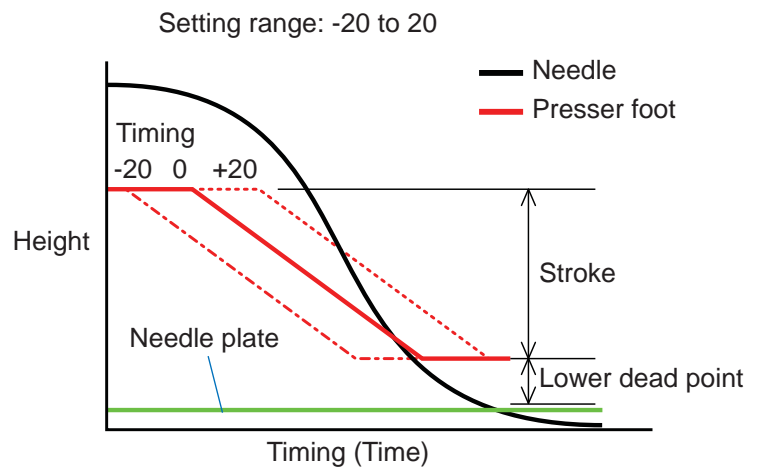
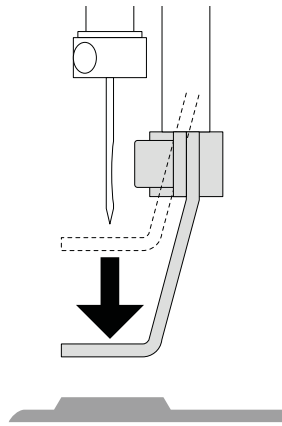

■ Settings for presser foot F. B. lower dead point

Set the height from the needle plate to the presser foot when performing Frame Back.

Setting range: 5.0 to 22.0 mm, R. (retracting position)

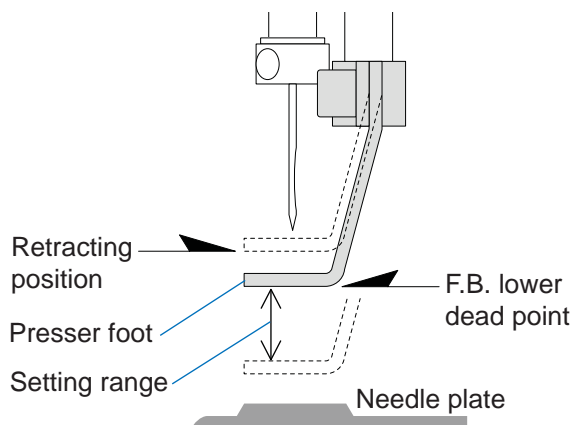

3-2. About Setting Operation

Presser foot settings are possible with any of the following three screens: Parameter setting screen, needle bar setting screen, and manual operation screen.

In the case of duplicated settings, those set in the needle bar setting screen will take precedence, followed by those set in the parameter setting screen or manual operation screen.

Settings on parameter setting screen

Make presser foot settings that serve as the basis of the entire machine or specified needle bar.

These are basic settings, so the machine will continue sewing with the same settings regardless of design changes.

Initial settings are registered in advance with parameters.

Furthermore, if settings are made on the needle bar setting screen, settings on the needle bar setting screen take precedence over parameter settings.

Settings on needle bar setting screen

Make presser foot settings for the selected design per step.

You can make presser foot settings that vary with each step for the same needle bar.

Values set on the needle bar setting screen are saved in design data.

Settings on manual operation screen

You can change presser foot settings during embroidery.

Make presser foot settings for the entire machine or for the needle bar currently being used.

Like parameter settings, the machine will continue sewing with the same settings regardless of design changes.

Values set on the manual operation screen are saved as parameter settings.



- For more information about the needle bar setting screen, refer to "Chapter 2 3-3. Settings on needle bar setting screen".
- For more information about the manual operation screen, refer to "Chapter 2 3-4. Settings on manual operation screen".

3-3. Settings on needle bar setting screen

Make presser foot settings per step for the selected design. The set value will be stored in design data.

You can make the following presser foot settings on the needle bar setting screen: presser foot lower dead point, presser foot stroke, presser foot timing, and presser foot F.B. lower dead point.

The following example shows how to set the height of the "presser foot lower dead point".



-  Settings for the "Presser foot lower dead point" are not possible while in "Auto mode". Use the parameter "i-TM mode" and set to "Manual mode".

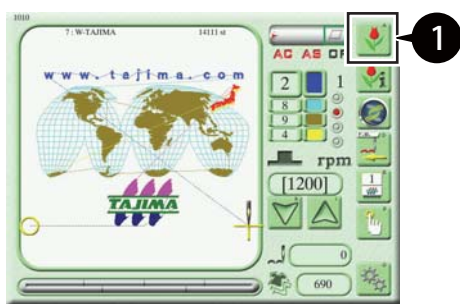

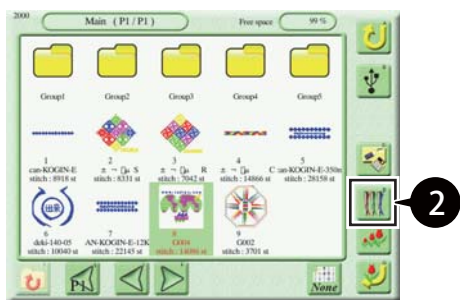

1 Press  on the main screen.

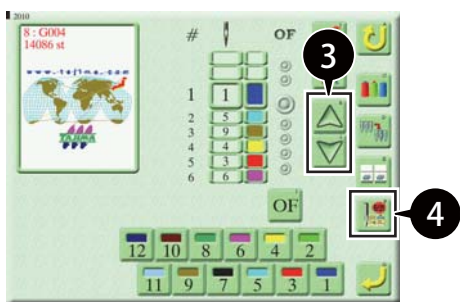

2 Press .



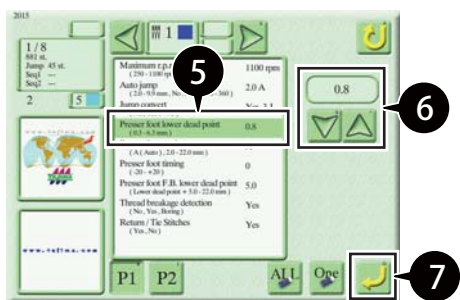

3 Press  , and select the step.

4 Press .



5 Select the "Presser foot lower dead point".

6 Press  , and set the height of the lower dead point.

7 Press .

3-4. Settings on manual operation screen

Make presser foot settings for the entire machine "Any" or for the needle bar currently being used.

Values set manually are saved as parameter settings for the entire machine.

You can make the following presser foot settings on the manual operation screen: lower dead point, stroke mode, stroke, timing, and F.B. lower dead point.

The following example shows how to set the height of the "lower dead point" of the needle bar currently being used.



- This operation cannot be operated when the functional limit level is set to "2".
-  Settings for the "Presser foot lower dead point" are not possible while in "Auto mode". Use the parameter "i-TM mode" and set to "Manual mode".

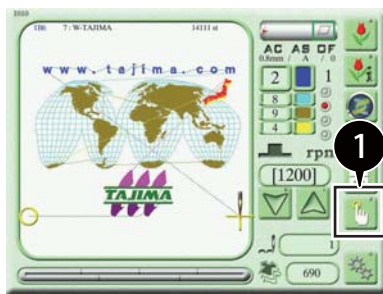

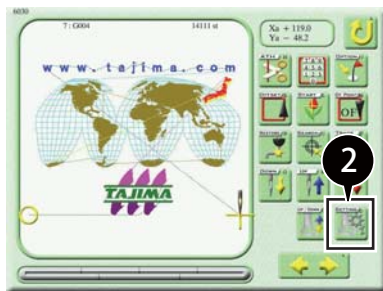

1 Press  on the main screen.

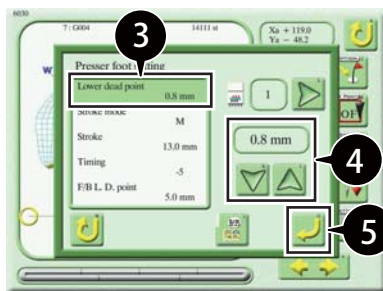

2 Press .



3 Select "Lower dead point".

4 Press  , and set the height of the lower dead point.



- When making "Stroke" settings, first set the "Stroke Mode" to "M" (Manual).

5 Press .

4. Responding to Thread Breakage

4-1. How to respond to a thread breakage indicator

When a thread breakage is detected, the machine automatically stops and the multi-color LED (right side) on the head where the thread breakage occurred lights up or blinks in red. In addition, a message screen appears on the operation panel.

How to respond to a thread breakage differs depending on whether the LED lights up or blinks and the code No. displayed.

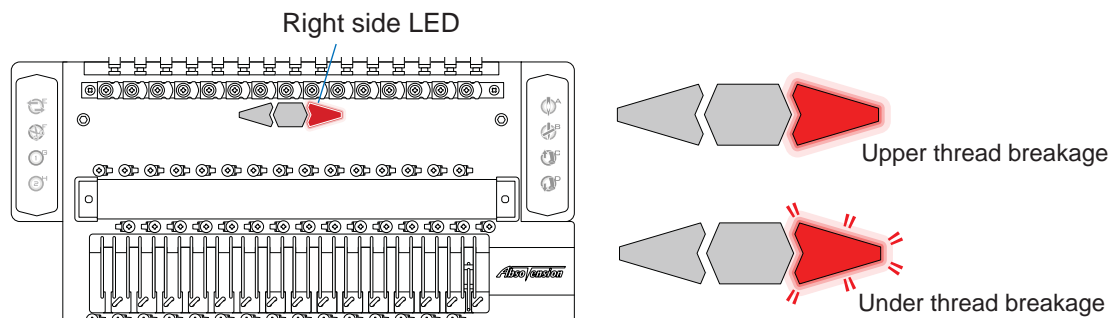

Display	Condition	Troubleshooting
Lit (Code No. 291)	Upper thread breakage	Pass the broken upper thread through the needle.
Blinking (Code No. 293)	Under thread breakage	Remove the bobbin from the rotary hook and check the condition of the under thread. If the under thread is lost or its remaining part is short, replace the bobbin with new one.



- Once you pass the upper thread or replace the under thread and resume embroidery, the message screen disappears.

4-2. Repair stitches

During the period between when a thread breakage occurs and when the machine stops, the frame advances without the thread by several stitches and thus a part of embroidery goes missing. To resume embroidery after a thread breakage, move back the frame from the position where it was stopped and resume embroidery at such a position that the seams overlap a little for better finishing.

■ An overview of repair stitches

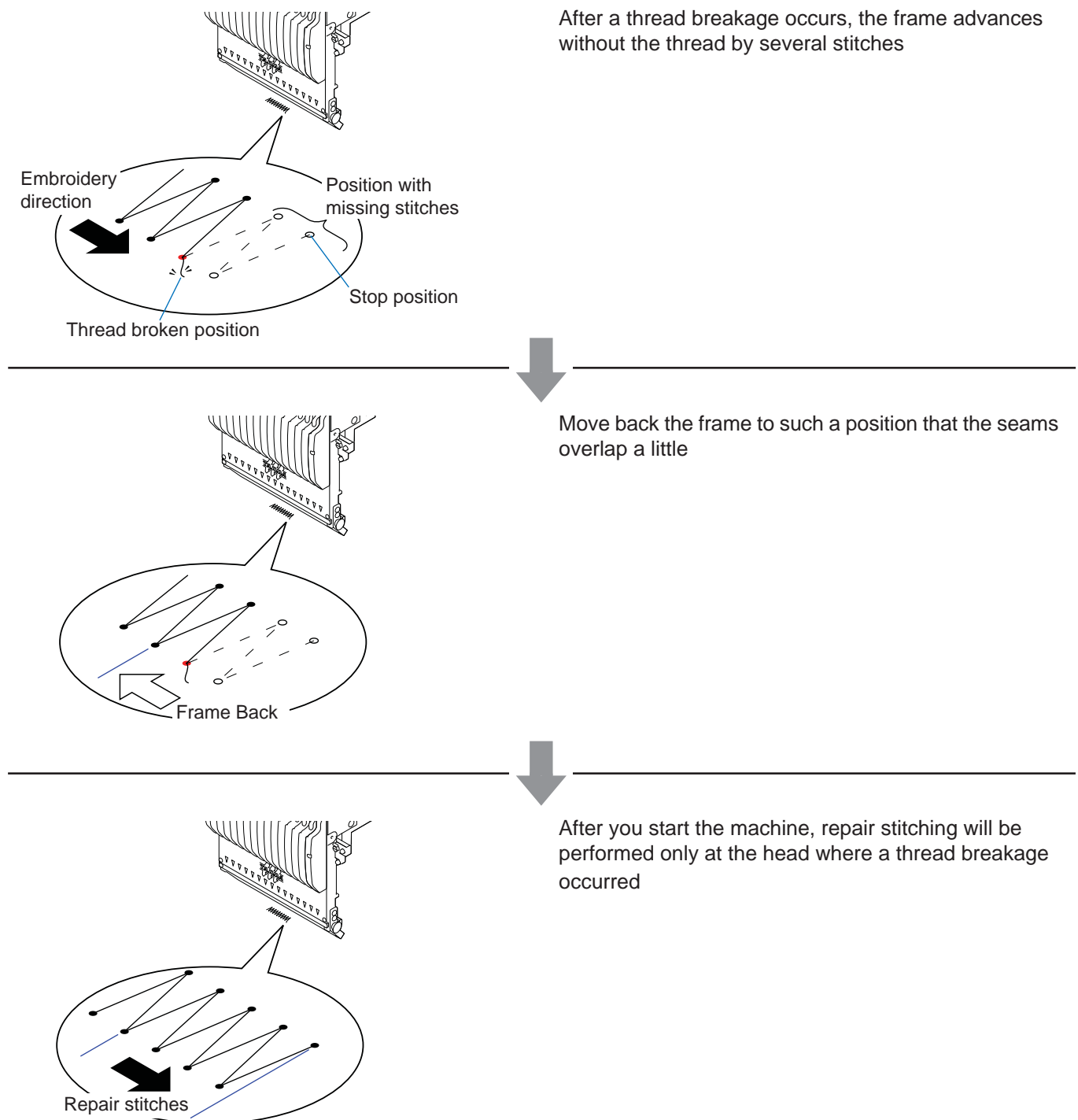

- If the "Auto F.B. after T. Detection" parameter is set to "Yes", the frame automatically moves back after a thread breakage. For details, refer to the separate "Parameter Settings" manual.

How to operate

The following example shows how to perform return stitching and repair stitching only at the head where a thread breakage occurred.



- For more information on return stitching, refer to "Chapter 1 4. Direct Command Switch".

Caution



Do not put your hands near the needles or on the table when you operate the machine because doing so may cause your finger or hand to be injured when the needle bar or frame moves.

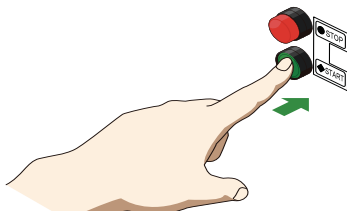
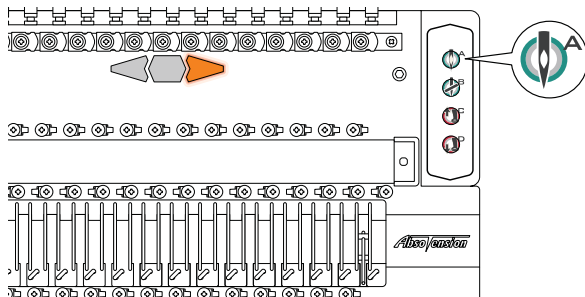
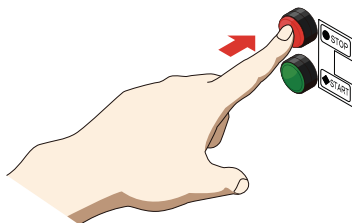

- Keep pressing the stop switch to move back the frame to such a position that the seams overlap a little.



- For more information on moving back the frame (Frame Back), refer to "Chapter 4 1. Moving Back or Moving Forward the Frame along the Stitches".

- Press once  on the tension base of the head where a thread breakage occurred. The multi-color LED (right side) changes in color from red to orange.

- Press the start switch. The machine starts up and performs return stitching and repair stitching.

Chapter 3

i-TM

1. Features of i-TM

The i-TM function optimizes the finish of sewing by pre-reading stitch data on the data-set design, determining the stitch type (running or satin stitch), sewing direction, and sewing pitch, and controlling the supply of upper thread on a stitch-by-stitch basis according to the result of determination.

Upper thread control will be automatically done on the i-TM tension base when embroidering, thus eliminating the operator's pre-adjustment to the tension of each upper thread. This will save time and effort in tension adjustment and test sewing.

■ Outline of function

When a design is stored in the machine memory, the i-TM function will automatically calculate predetermined control data for each stitch. Furthermore, control data is grouped per needle bar step and stored as a control pattern for the design.

Therefore, in the case of sewing the same design, the supply of upper thread will be controlled according to the stored control pattern for the design.

Each control pattern is stored for the design with the Pattern Number (Machine number_N Needle bar No.).

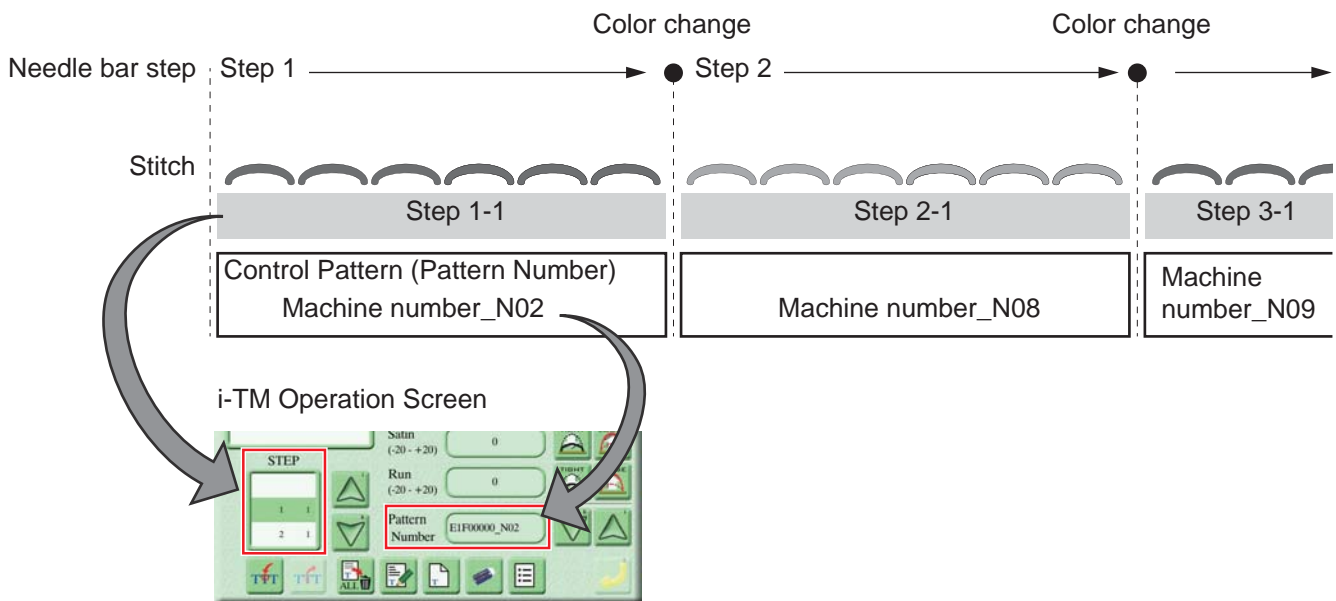

The control pattern can be edited as follows:

- Splitting the control pattern for each needle bar step and sub-splitting the control pattern.
- Overwriting and saving the adjusted control pattern or storing it with a different name.

■ Mode switching

The i-TM operates in Auto mode or Manual mode. Use the parameter "i-TM mode" to change the mode.

- Auto mode: Each i-TM parameter can be adjusted automatically by measuring the fabric thickness (Default).
- Manual mode: Each i-TM parameter can be adjusted manually.

2. i-TM Operation Screen

To display the i-TM operation screen, press  on the main screen.



-  The screen is not displayed while in "Auto mode". Use the parameter "i-TM mode" and set to "Manual mode".

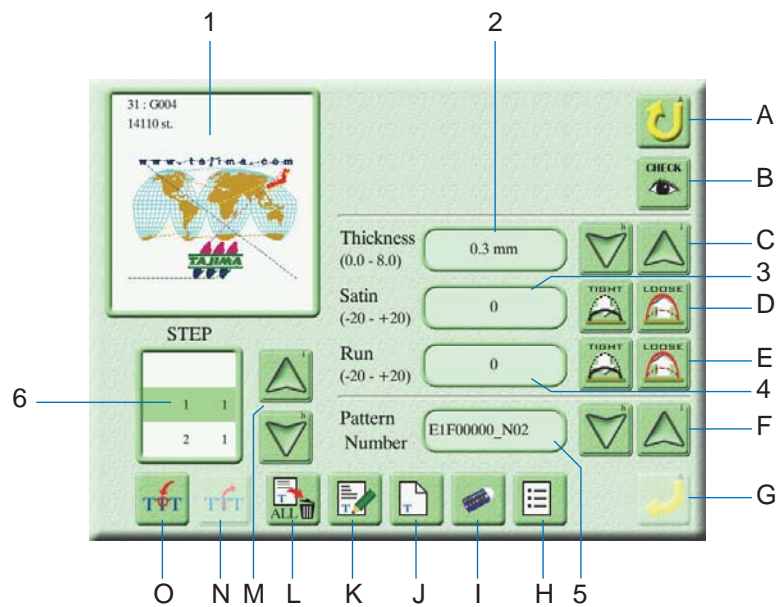

No.	Description	No.	Description
1	The selected step blinks	E	Running stitch change
2	The setting value of the current fabric thickness	F	Control pattern change
3	The setting value of the current satin stitch	G	Saving the setting
4	The setting value of the current running stitch	H	Navigate to the pattern list screen
5	Current control pattern (Pattern Number)	I	Resetting of the selected control pattern
6	Selected step	J	Storing the control pattern with a name
A	Back (return to the previous screen)	K	Overwriting and saving the control pattern
		L	Batch resetting of all the control patterns
B	Navigate to the check screen	M	Step selection and scroll
C	Fabric thickness change	N	Step deletion
D	Satin stitch change	O	Split of step

3. Adjusting the Finish of Sewing

You can make thread tightening adjustments for each type of stitch depending on the finish of sewing of the design.

3-1. Adjusting the thread tightening

Fabric thickness change

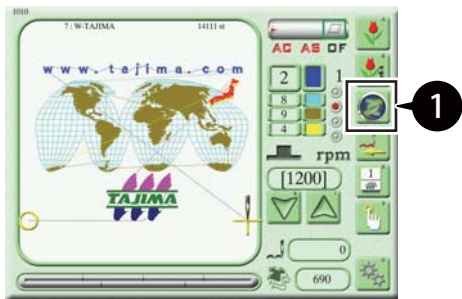

1 Press  on the main screen.



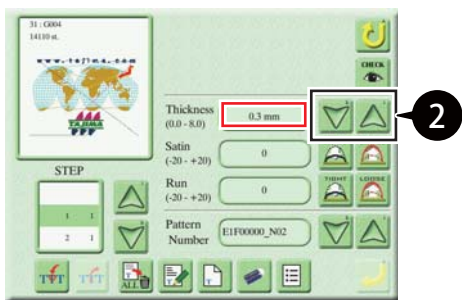

-  While in "Auto mode", use the parameter "i-TM mode" and set to "Manual mode".

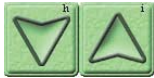

2 Press  to set the fabric thickness (Thickness).
The new setting appears in the red box.

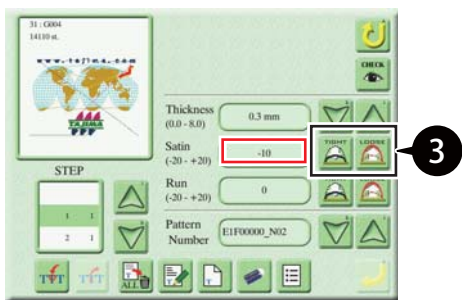
Satin stitch adjustment



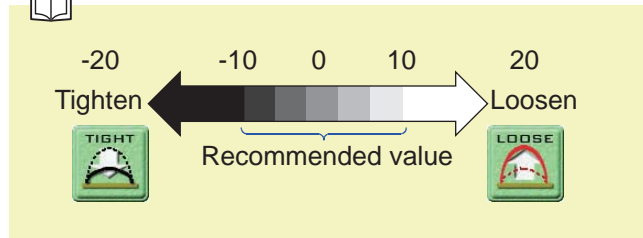

3 Press  to adjust the satin stitch (Satin) thread tightening.
The new setting appears in the red box.

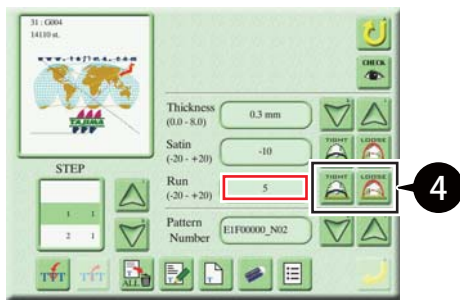

- Lower the detecting sensitivity of thread breakage in the case of the mis-detection of thread breakage if the satin stitch is set to an extremely large or small value. For details, refer to the separate "Parameter Settings" manual.

Running stitch adjustments



- 4 Press   to adjust the running stitch (Run) thread tightening.

The new setting appears in the red box.



- Lower the detecting sensitivity of thread breakage in the case of the mis-detection of thread breakage if the running stitch is set to an extremely large or small value. For details, refer to the separate "Parameter Settings" manual.

Storing control pattern



- 5 Store the setting value in the control pattern.



: Storing with a name



: Overwriting and saving



- For details of storing the setting value with a name, refer to "Chapter 3 4-1. Storing the control pattern with a name".
- For details of overwriting and saving the setting value, refer to "Chapter 3 4-2. Overwriting and saving the control pattern".

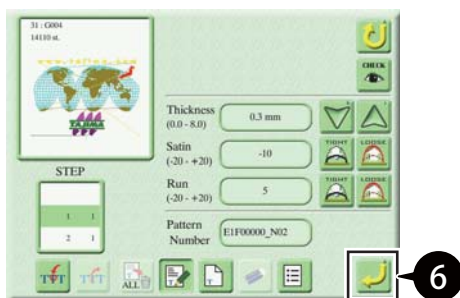

- 6 Press .

The setting will be stored.

3-2. Adjusting the thread tightening during operation

You can check and make thread tightening adjustments while the machine is in operation.



- Satin stitch and running stitch changes are possible while the machine is in operation.

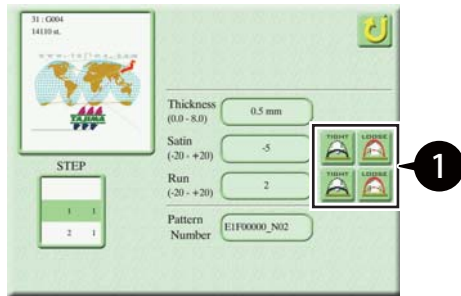

- 1 Temporarily adjust the thread tightening of the satin stitch or running stitch on the i-TM setting screen.



- For adjustments to the thread tightening of the satin stitch and running stitch, refer to "Chapter 3 3-1. Adjusting the thread tightening".

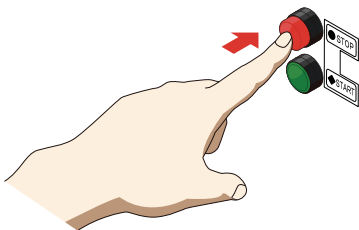

- 2 Press the stop switch and check the stitch. When the machine stops, the temporary adjustment value returns to the value before adjustment.



- The value of temporary adjustment will not be reflected in the control pattern at the moment the stop switch is pressed.

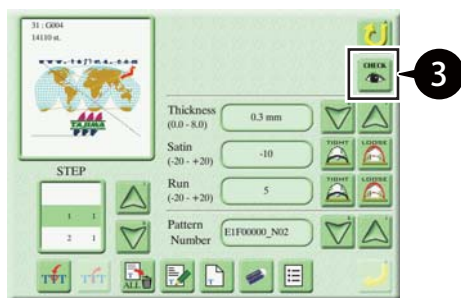

- 3 Press  .

The temporary adjustment value is displayed.



- If the control pattern changes during temporary adjustment, the temporary adjustment value will be cleared, and the value will not be displayed with

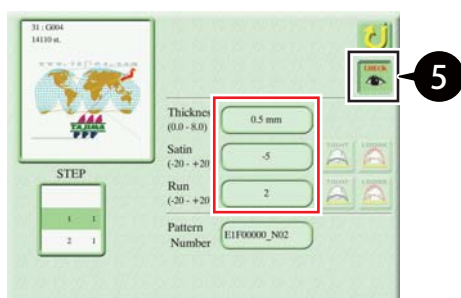
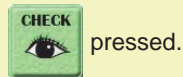

- 4 Check the value of temporary adjustment (red frame part).

- 5 Press  .

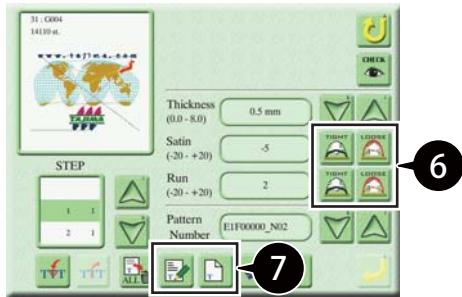

- 6 Set the thread tightening of the satin stitch or running stitch by referring to the temporarily adjusted value confirmed at step 4.



- For thread tightening settings for the satin stitch and running stitch, refer to "Chapter 3 3-1. Adjusting the thread tightening".

- 7 Store the setting value in the control pattern.



: Storing with a name



: Overwriting and saving



- For details of storing the setting value with a name, refer to "Chapter 3 4-1. Storing the control pattern with a name".
- For details of overwriting and saving the setting value, refer to "Chapter 3 4-2. Overwriting and saving the control pattern".

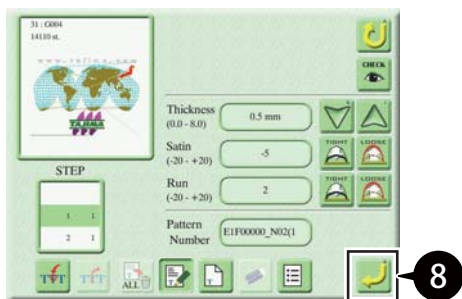

- 8 Press .

The setting will be stored.

4. Storing the Control Pattern (Pattern Number)

You can store the changed fabric thickness and thread tightening setting for the adjusted stitch in a control pattern.



- The default setting for a control pattern is "Machine number_N Needle bar No.", and all control pattern setting values are the same.
- You can create up to 1,000 control patterns per design.

4-1. Storing the control pattern with a name

You can store the changed fabric thickness or thread tightening setting for the adjusted stitch in a control pattern with a name.

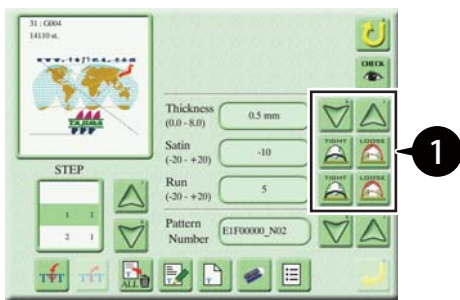

- 1 Make fabric thickness settings or thread tightening settings for the stitch on the i-TM setting screen.



- For fabric thickness settings or stitch thread tightening settings, refer to "Chapter 3 3. Adjusting the Finish of Sewing".

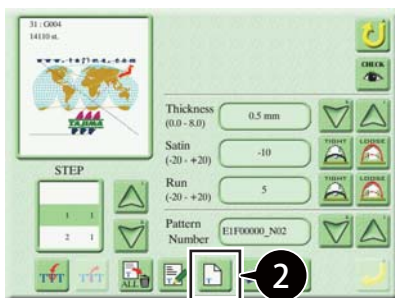

- 2 Press .

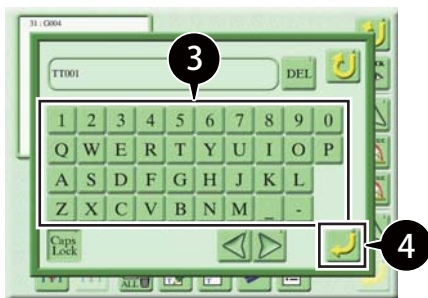

- 3 Enter the new control pattern name (for example TT001).



- You can enter a control pattern name up to 24 characters long.
- Press  to toggle between uppercase and lowercase.

- 4 Press .

The setting for the new control pattern will be stored.

4-2. Overwriting and saving the control pattern

You can overwrite and save the changed fabric thickness and thread tightening setting for the adjusted stitch in a control pattern.

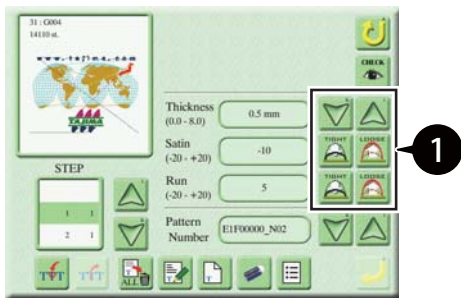

- 1 Make fabric thickness settings or thread tightening settings for the stitch on the i-TM setting screen.



- For fabric thickness settings or stitch thread tightening settings, refer to "Chapter 3 3. Adjusting the Finish of Sewing".

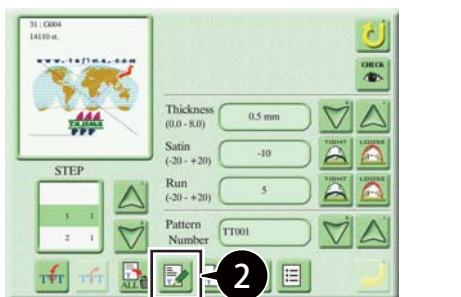

- 2 Press .



- The save method is different if there is more than one control pattern with the same name in one design. For details, refer to "Chapter 3 5-1. Dividing step and setting".



- 3 Press .

The setting for the control pattern will be overwritten and saved.

5. Dividing Step

You can divide the control pattern for each needle bar step for the segmentation of the control pattern.

[In the case of dividing the needle bar step 2]

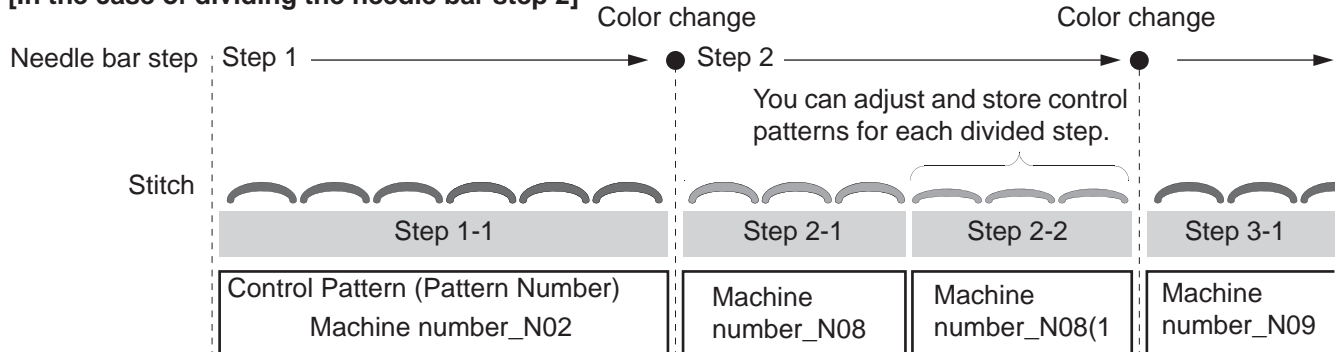

5-1. Dividing step and setting

You can divide the step before and after the specified stitch No. and set a control pattern.

The previous step includes all the stitches before the specified stitch No.

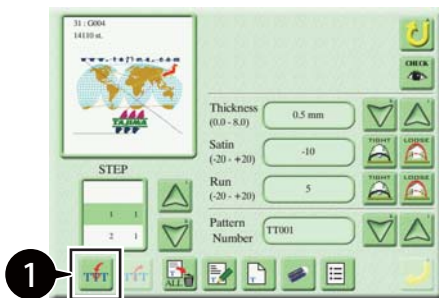

The following example shows how to divide the step with stitch No. 912 specified.

■ Dividing step



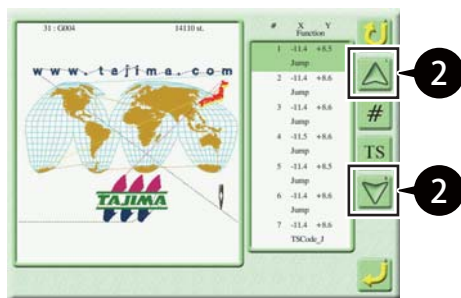

1 Press  on the i-TM setting screen.



2 Press   and move to the stitch in the dividing position.



- Hold down   to change the display in units of seven stitches.
- Pressing  will display a numerical key so that you can input the stitch No. in the dividing position and move to the target position.

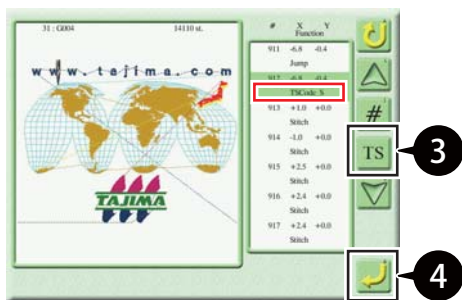

3 Press **TS** and specify the stitch in the dividing position.

The function code display of your specified stitch will change (as shown in the red box).



- Function code display change
 "TSCode_S" : Stitch
 "TSCode_J" : Jump

4 Press .

5 Press **Yes** .

The step is divided.

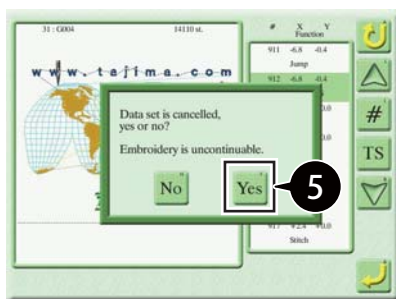

■ Setting and storing a control pattern

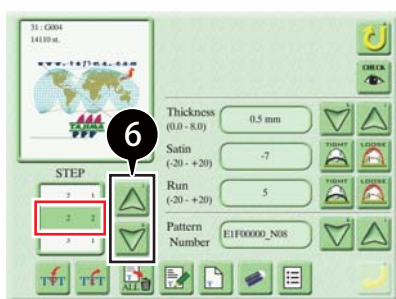

6 Press and select the divided step.
 The selected step appears in the red box.

7 Make fabric thickness settings or stitch thread tightening settings.



- For fabric thickness settings or stitch thread tightening settings, refer to "Chapter 3 3. Adjusting the Finish of Sewing".

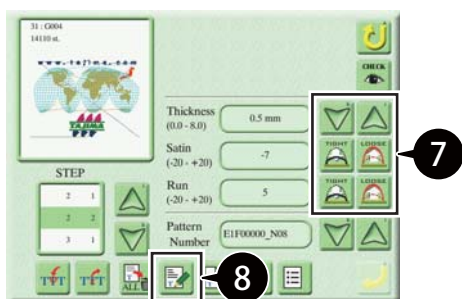

8 Press .

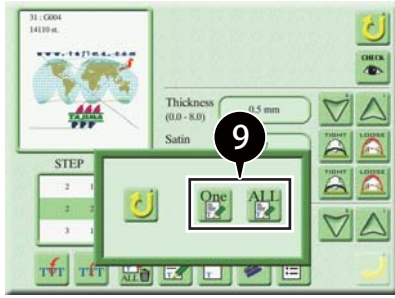

9 Select the storage method.



: Overwriting and saving the selected control pattern



: Overwriting and saving all the control patterns with the same name

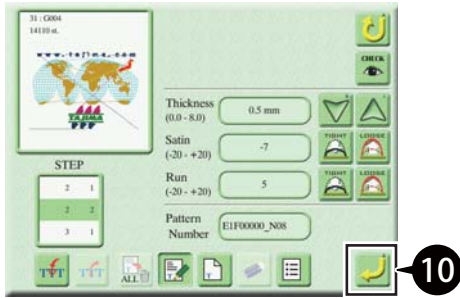

10 Press .

The setting for the control pattern will be stored.

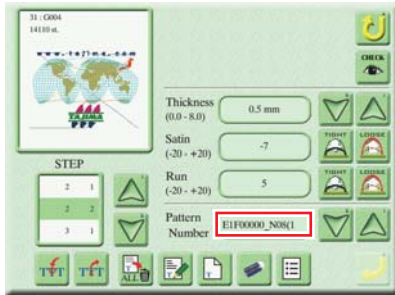



- If there are two or more control patterns with the same name, a number will be added at the end of the control patterns (as shown in the red box).

5-2. Deleting divided step

You can delete the divided step.

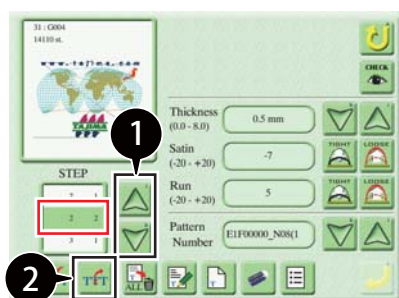
You cannot delete steps unless they have been divided and created.



- 1 Press  and select the divided step on the i-TM setting screen.
The selected step appears in the red box.

- 2 Press  .



-  is valid only if the divided step is selected.

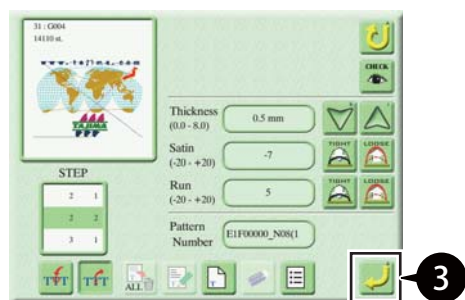



- 3 Press  .
The selected step is deleted.

6. Resetting of the Control Pattern

6-1. Resetting of the selected control pattern

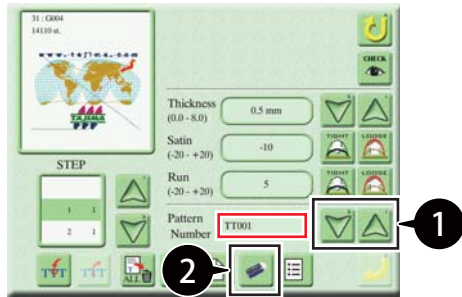
You can reset the name and set value of the selected control pattern.



1 Press   and select the target control pattern on the i-TM setting screen.
The selected control pattern appears in the red box.

2 Press .

3 Press .

The control pattern is reset.

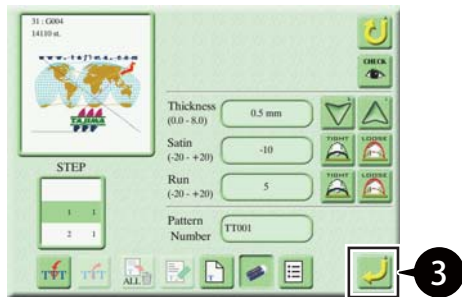

- Setting value after the control pattern reset
 Fabric thickness: 0.3 mm
 Satin stitch: 0
 Running stitch: 0
 Pattern Number: Machine number_N Needle bar No.

6-2. Batch resetting of all the control patterns

You can batch reset the names and set values of all the control patterns saved for the design.



- Divided steps will remain, but the set values of the control patterns allocated will be reset.



- Press  on the i-TM setting screen.

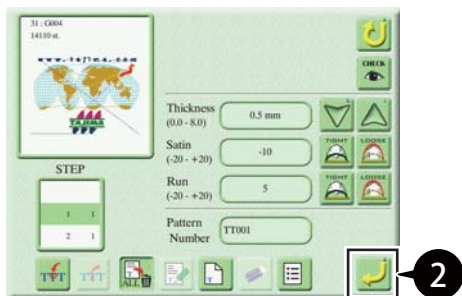

- Press . The control pattern is reset.





- Setting value after the control pattern reset
 Fabric thickness: 0.3 mm
 Satin stitch: 0
 Running stitch: 0
 Pattern Number: Machine number_N Needle bar No.

7. List Display and Editing of Control Patterns

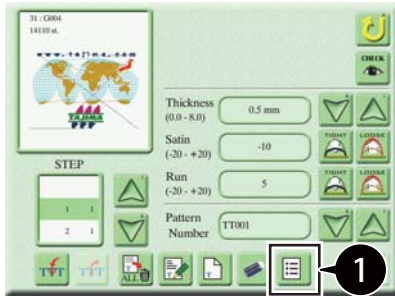

You can display a list of data-set design control patterns. Furthermore, you can edit or delete any of them independently.

7-1. List display of control patterns

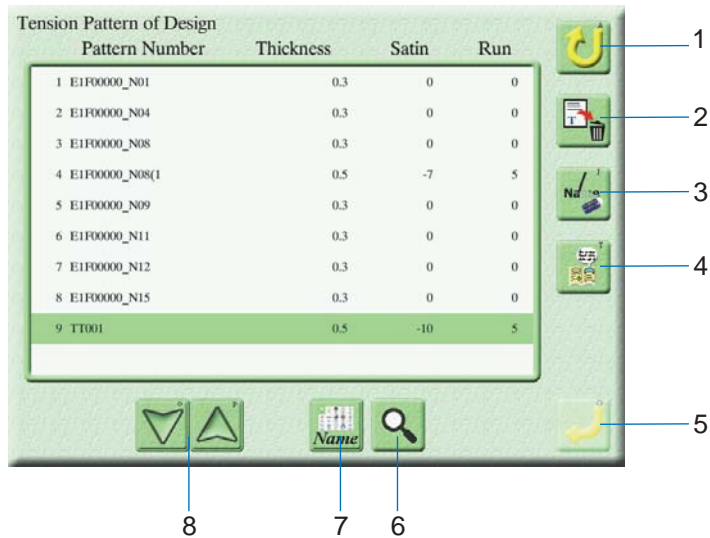

- 1 Press  on the i-TM setting screen.
The pattern list screen appears.



No.	Description
1	Return to the previous screen
2	Delete control patterns (Control patterns grouped per needle bar step will not be deleted but their names and setting values will be reset)
3	Change control pattern name
4	Navigate to the detailed setting screen
5	Decision
6	Search by control pattern name
7	Switch ascending order  : Name  : Updating time
8	Switch display page

7-2. Searching control pattern by name



1 Press  on the pattern list screen.

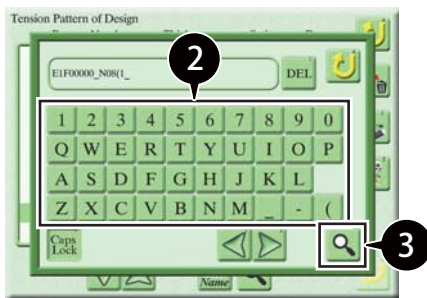

2 Enter the control pattern name (for example E1F0000_N08(1) to be searched for.



- You cannot search unless you enter the full name.
- Press  to toggle between uppercase and lowercase.

3 Press .

The input control pattern appears in the red box.

7-3. Adjusting fabric thickness and stitch thread tightening (detailed setting screen)

You can change the fabric thickness of the specified control pattern or change the adjustment to stitch thread tightening.



- Contact the distributor for adjustments other than fabric thickness, satin stitch, and running stitch.



1 Select the target control pattern (for example TT002) to change the setting on the pattern list screen.

2 Press .

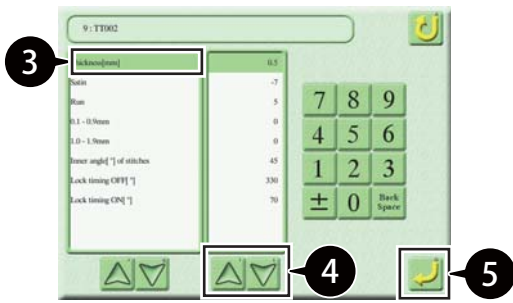

3 Select the setting you want to change (for example Thickness [mm]).

4 Press   and change the value.

5 Press .

The setting will be changed.

7-4. Deleting control pattern

You can delete the specified control pattern.

You cannot delete control patterns grouped per needle bar step but their names and setting values will be reset.



1 Select the target control pattern (for example E1F0000_N08(1)) to be deleted on the pattern list screen.

2 Press .



3 Press .

The selected control pattern will be deleted.



- In the case of control patterns grouped per needle bar step, their names and setting values will be reset.
- Setting value after the control pattern reset
 Fabric thickness: 0.3 mm
 Satin stitch: 0
 Running stitch: 0
 Pattern Number: Machine number_N Needle bar No.

7-5. Changing control pattern name

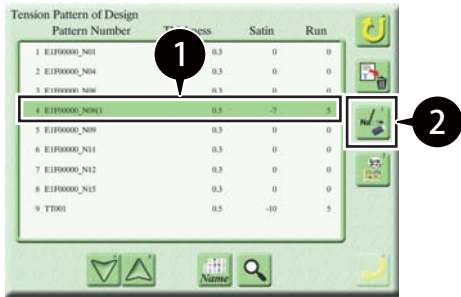

1 Select the target control pattern (for example E1F0000_N08(1)) to be changed the name on the pattern list screen.

2 Press .

3 Input the control pattern name (for example TT002).

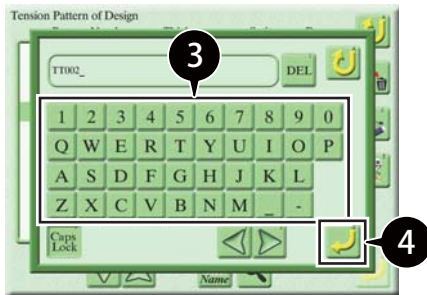

- You can enter a control pattern name up to 24 characters long.
- Press  to toggle between uppercase and lowercase.

4 Press .

The control pattern name will be changed.

Chapter 4

Manual Operation

1. Moving Back or Moving Forward the Frame along the Stitches

You can move back (Frame Back) or forward (Frame Forward) the frame along the stitches with the needle bar stopped.

This feature is useful when you want to:

- Resume embroidery from a stitch before the position where a thread breakage occurred for the purpose of performing repair stitching after a thread breakage
- Resume embroidery from within the design or from an intermediate step
- Skip an area within the design or an intermediate step

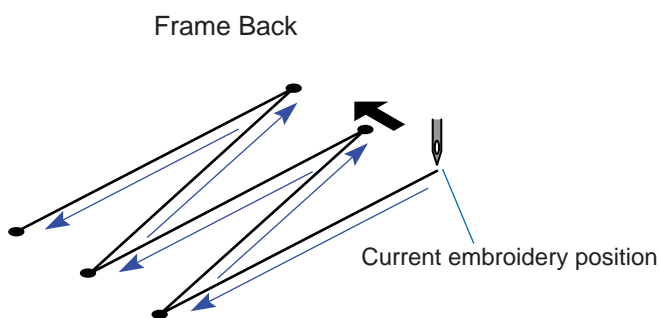

The frame will be moved to the direction where stitches return with the needle bar stopped.

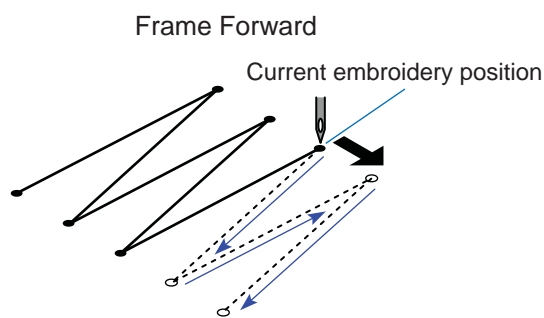

The frame will be moved to the direction where stitches advance with the needle bar stopped.

You can use the Frame Back and Frame Forward features in one of the following three ways:

Method	Unit	Detail
Stop switch	Stitch	Move back/forward the frame on a stitch by stitch basis along the stitches.
Operation panel		Move back/forward the frame across the stitch count you specify.
Operation panel	Color change	Move back/forward the frame by the number of color change codes you specify.

1-1. Frame Back/Frame Forward by 1-stitch unit

You can use the stop switch to move back or forward the frame on a stitch by stitch basis.

⚠ Caution

- Do not put your hands on the table when you operate the machine because doing so may cause your finger or hand to be injured when the frame moves.

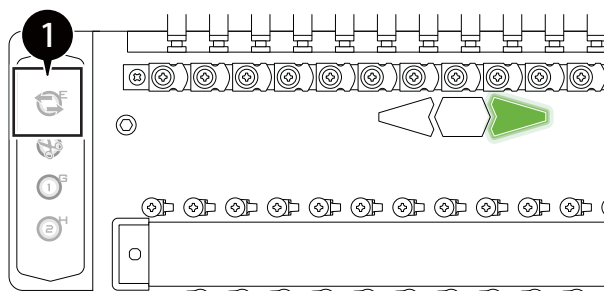

- Press  on the tension base to switch between Frame Back and Frame Forward.



- The multi-color LED lighting color changes every time you press the switch. The setting changes after the LED is lit in white for two seconds.

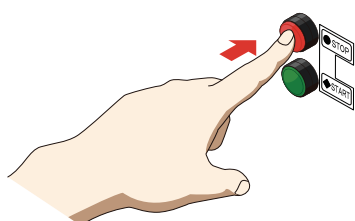
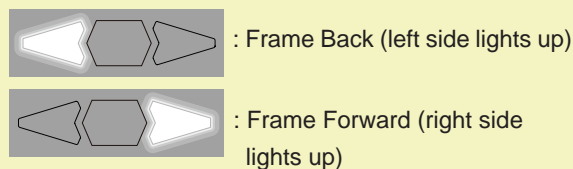

- Press the stop switch and hold it in that position. The frame moves on a stitch by stitch basis along the stitches.
- Release the stop switch when the frame moves to the desired frame position (within 10 stitches). The frame stops moving.

■ High-speed travel of Frame Back/Frame Forward

Hold down the stop switch on hold for 11 or more stitches switches to high-speed travel (feed unit). To stop high-speed travel, release the switch once and press the stop switch.

In this mode, you can configure the frame feed amount for high-speed travel. For details, refer to the separate "Parameter Settings" manual.

[Frame Back]

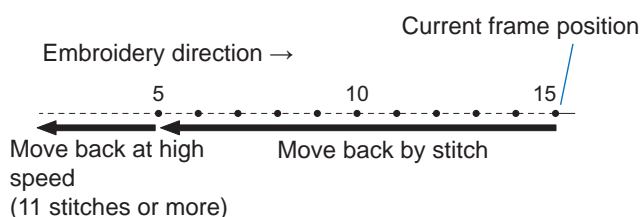

[Frame Forward]

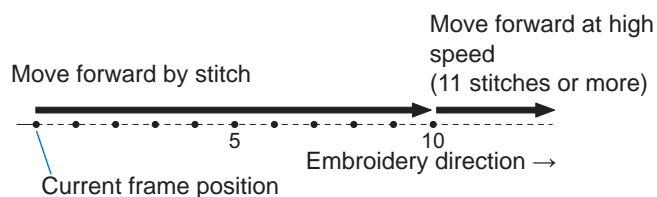

1-2. Frame Back/Frame Forward by specifying the number of stitches

You can move back or forward the frame by the number of stitches you specify

⚠ Caution

- ⊘ Do not put your hands on the table when you operate the machine because doing so may cause your finger or hand to be injured when the frame moves.

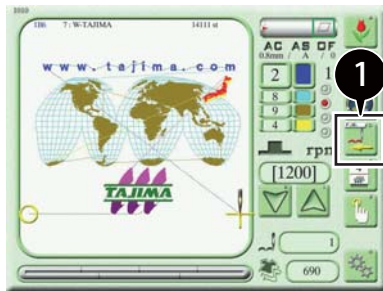

- 1 Press  on the main screen.

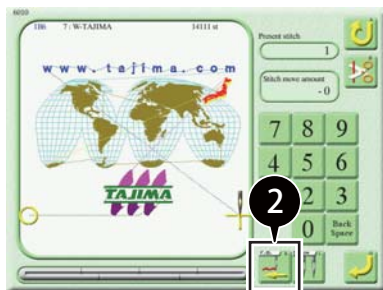

- 2 Select the direction in which to feed the frame.



: Frame Back



: Frame Forward

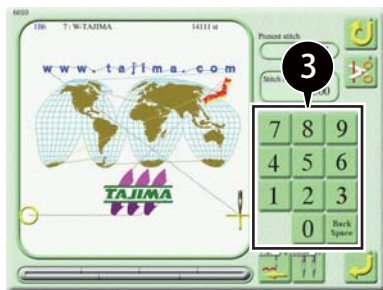

- 3 Input the number of stitches (for example, 500).

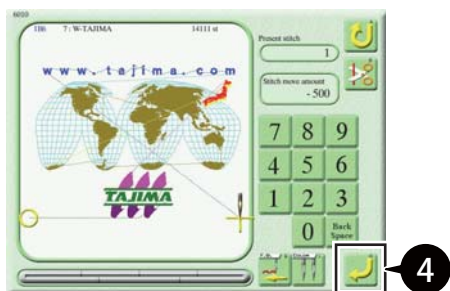

- 4 Press  .
The frame moves along the stitches by the specified number of stitches.

1-3. Frame Back/Frame Forward by specifying the number of color change

You can move back or forward the frame by the number of color changes you specify.

Caution

-  Do not put your hands on the table when you operate the machine because doing so may cause your finger or hand to be injured when the frame moves.

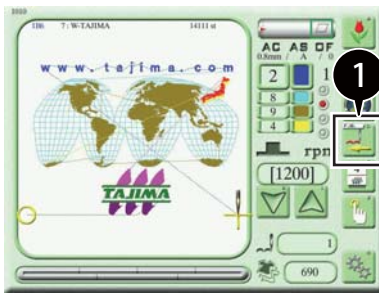

- 1 Press  on the main screen.

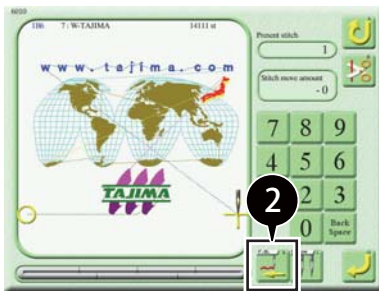

- 2 Select the direction in which to feed the frame.



: Frame Back



: Frame Forward

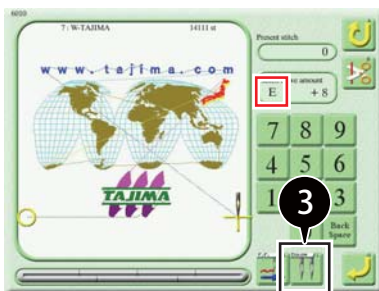

- 3 Press  as many times as the desired number of color changes.



- "E" appears in the red box if there is no next color change and the current color change is the last one.

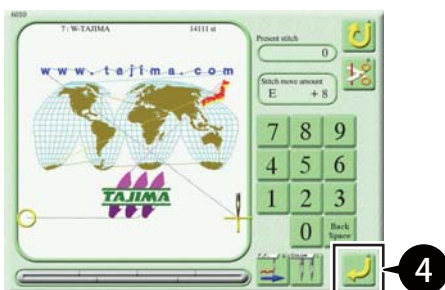

- 4 Press  .
The frame moves along the stitches by the specified number of color changes.

2. Thread Trimming

2-1. Operating the ATH

You can trim both the upper and under threads or only the under thread.

⚠ Caution

- ⊘ Do not put your hands near the needles or on the table when you operate the machine because doing so may cause your finger or hand to be injured when the needle bar or frame moves.



- You can also perform thread trimming by holding down the F switch on the tension base. For details, refer to "Chapter 1 4. Direct Command Switch".

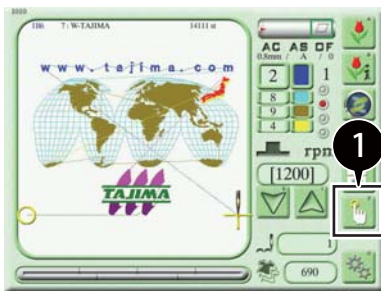

1 Press  on the main screen.

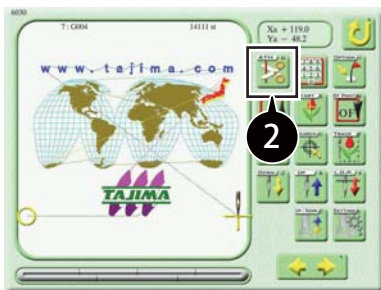

2 Press .



3 Execute thread trimming.

 : Under thread only

 : Upper thread and under thread

3. Needle Bar Related Operations

3-1. Color Change

A color change is performed by sliding the needle bar case and switching the needle bar at the sewing needle to a different needle bar.

Caution

-  Do not bring your hand close to the needle bar case when you operate the machine because doing so may cause your finger or hand to be injured when the needle bar case moves.



- If the thread is connected to the fabric, trim the thread before the color change.
- If you manually switch the needle bar and want to use the new one for embroidery, set the "Auto Color Change (AC)" parameter to "NO".
For details, refer to the separate "Parameter Settings" manual.

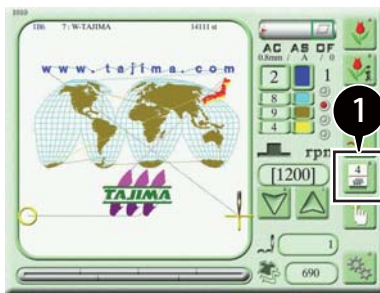

- Press  on the main screen.

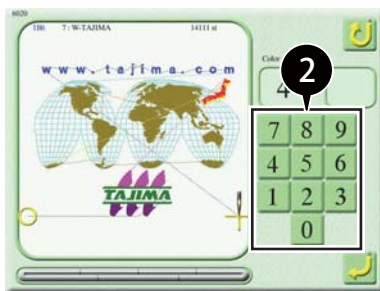

- Select the new needle bar No. (for example, needle bar No. 8).

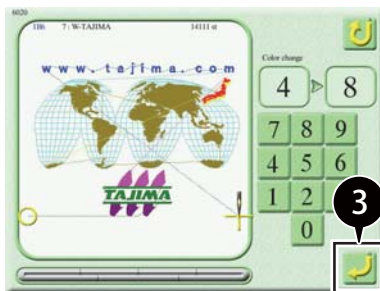

- Press .
The needle bar case slides and the needle bar switches to the new one.

3-2. Raising or lowering the needle bar

You can lower or raise the selected needle bar.

Caution

 Do not put your hands near the needles when you operate the machine because doing so may cause your finger or hand to be injured when the needle bar raises or lowers.

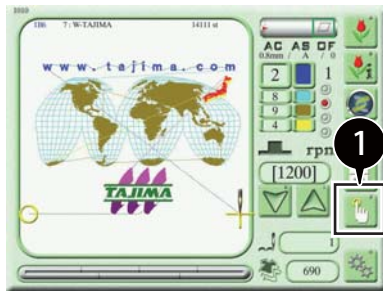

1 Press  on the main screen.

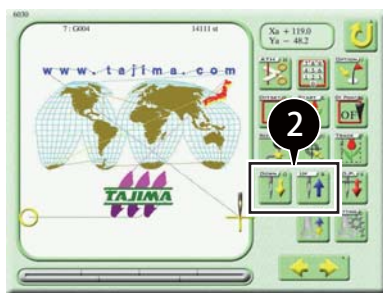

2 Raise or lower the needle bar.



: Lower the needle bar.



: Raise the needle bar.

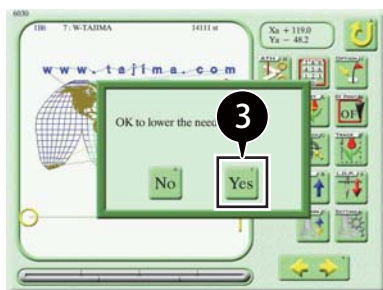

3 Press .

The needle bar is lowered or raised.

3-3. Stopping the needle bar at the lower dead point

You can lower the selected needle bar to the lower dead point.



- Since the needle bar lowers to the lower dead point, the needle remains penetrating the fabric. This feature is useful when you embroider consecutively on the long fabric.

Caution

- ⊘ Do not put your hands near the needles when you operate the machine because doing so may cause your finger or hand to be injured when the needle bar lowers.

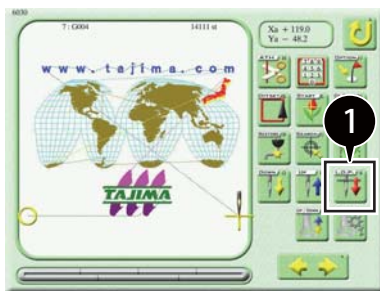

- 1 Press  on the manual operation screen.



- 2 Press  .
The needle bar lowers to the lower dead point.

3-4. Raising or lowering the presser foot

You can lower or raise the selected needle bar presser foot.

⚠ Caution

⊘ Do not put your hands near the needles when you operate the machine because doing so may cause your finger or hand to be injured when the presser foot raises or lowers.

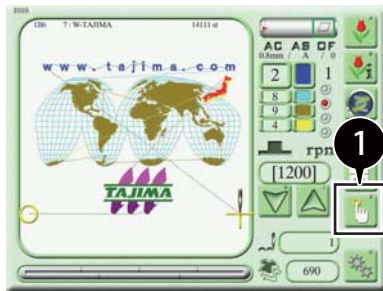

1 Press  on the main screen.

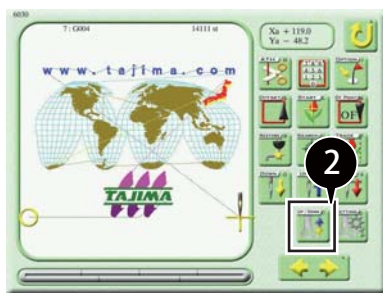

2 Press .

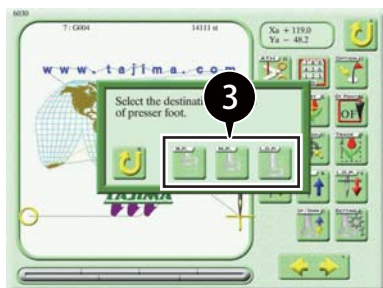

3 Raise or lower the presser foot.



: Retracting position



: Frame Back Position



: Lower dead point of presser foot

4. Various Frame Movement Operations

4-1. Moving the frame to the preset optional position

You can move the frame to a preset optional position.





- For more information on presetting a frame position, refer to the separate "Parameter Settings" manual.

Caution

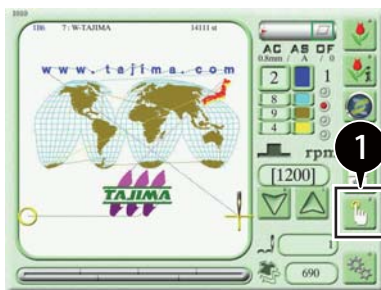

Do not put your hands on the table when you operate the machine because doing so may cause your finger or hand to be injured when the frame moves.



- Press  on the main screen.

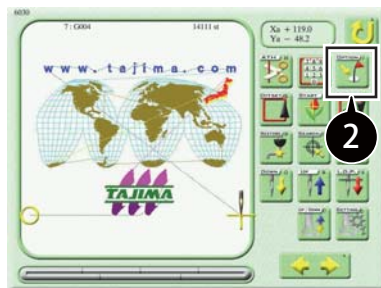

- Press .

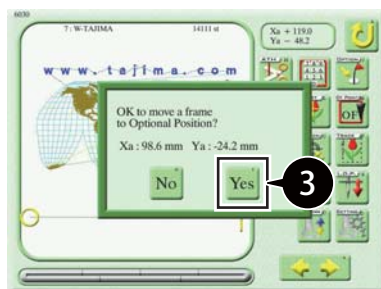

- Press .

The frame moves to the preset optional position.

4-2. Moving the frame to the original position (manual offset)

You can move the frame to the original position after you have moved it manually during embroidery.

⚠ Caution

⊘ Do not put your hands on the table when you operate the machine because doing so may cause your finger or hand to be injured when the frame moves.

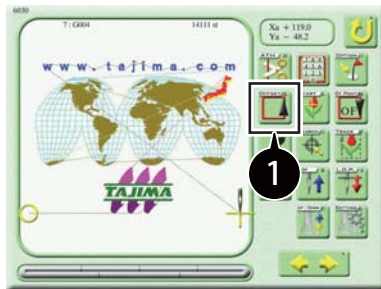

1 Press  on the manual operation screen.

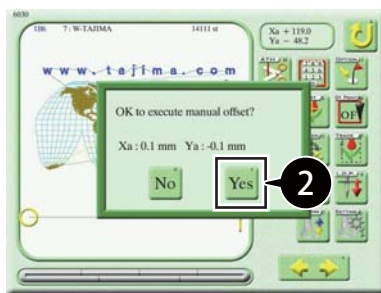

2 Press  .
The frame moves to the original position.

4-3. Moving the frame to the start position

You can move the frame to the start position during embroidery.

⚠ Caution

⊘ Do not put your hands on the table when you operate the machine because doing so may cause your finger or hand to be injured when the frame moves.

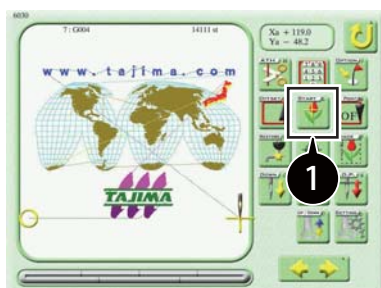

1 Press  on the manual operation screen.

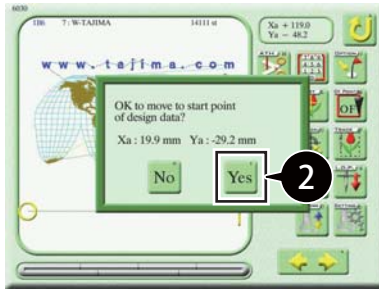

2 Press  .

The frame moves to the start position.

4-4. Moving the frame to the offset position

You can move the frame to the offset position.

The offset position is a position where the frame is automatically moved (offset toward you) during and after embroidery and put into standby for ease of replacing the frame or fabric.



- To move the frame to the offset position, you must preset it. For details, refer to the separate "Advanced Operation" manual.

Caution

-  Do not put your hands on the table when you operate the machine because doing so may cause your finger or hand to be injured when the frame moves.

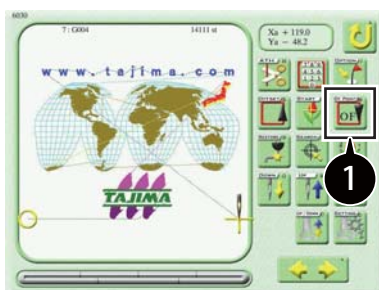

1 Press  on the manual operation screen.

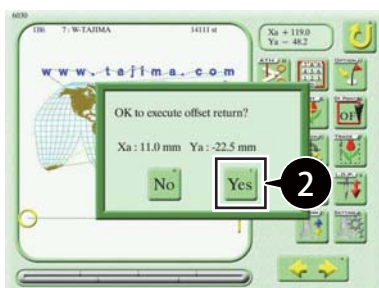

2 Press  .

The frame moves to the offset position.

4-5. Moving the frame by entering a numeric value

You can move the frame by entering a numeric value.





- The value you enter is the amount of travel from the current frame position.

⚠ Caution

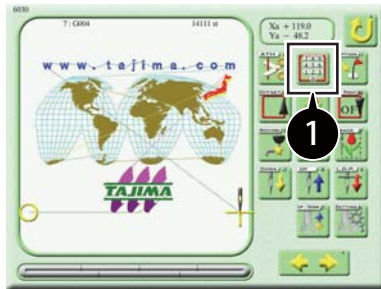

Do not put your hands on the table when you operate the machine because doing so may cause your finger or hand to be injured when the frame moves.



1 Press  on the manual operation screen.



- Pressing the coordinate icon will change the indication.

- Current frame position

$X_a + 19.2$
 $Y_a + 98.7$: Based on absolute origin

$X_r + 0.0$
 $Y_r + 0.0$: Based on the start position

- Frame Travel amount from current frame position

$X_m - 20.0$
 $Y_m + 15.0$: Travel amount you enter

$X_m -$ (minus sign): Frame moves to right

+ (plus sign): Frame moves to left

$Y_m -$ (minus sign): Frame moves to rear

+ (plus sign): Frame moves to front

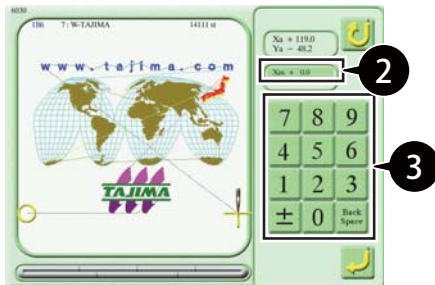

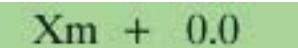
2 Press  .

3 Enter the X-axial travel amount (for example, +60.0).

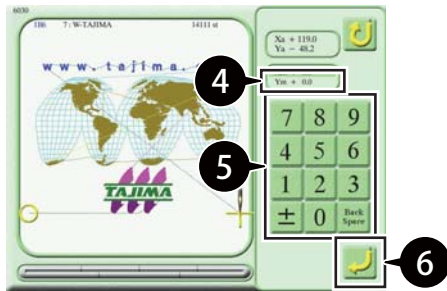

4 Press **Ym + 0.0** .

5 Enter the Y-axis travel amount (for example, -85.0).

6 Press  .

The frame moves to the specified position.

4-6. Absolute origin search

Be sure to execute absolute origin search after you have moved the frame by hand with the power OFF.



The absolute origin of the frame is a reference point ($X_a = 0.0$, $Y_a = 0.0$) to calculate the current frame position.

If the absolute origin is not correctly registered, the following problems may occur:

- The frame coordinates are not displayed correctly.
- After emergency stop or power failure, turning ON the power fails to return the frame to the position where the operation was suspended.

Caution

-  Do not put your hands on the table when you operate the machine because doing so may cause your finger or hand to be injured when the frame moves.

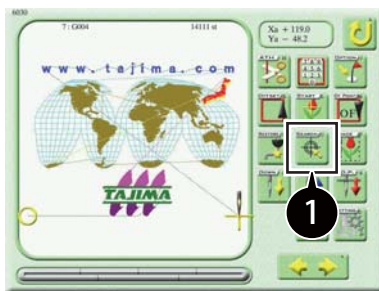

1 Press  on the manual operation screen.



2 Press **Yes** .

The frame will move to the absolute origin and return to the original position.

4-7. Power Resume

You can return the frame to the position where it was when the power was turned OFF.



- If you moved the frame by hand with the power OFF during embroidery and now want to return it to the original position, turn ON the power and manually perform power resume. This feature requires that the absolute origin of the frame is correctly registered.

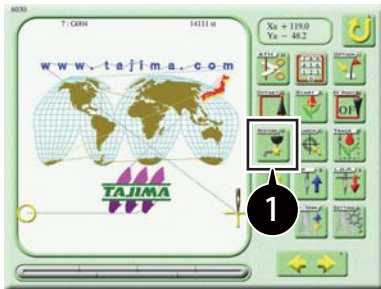

1 Press  on the manual operation screen.



2 Select the power resume method.



: Perform power resume after trimming the thread.



: Perform power resume without trimming the thread.



- When you perform power resume, the machine checks the absolute origin and the frame moves to a position several stitches back from the position where it was when the power was turned OFF.

5. Other Operation

5-1. Turning ON/OFF the LED lamp

You can turn ON/OFF the LED lamp.

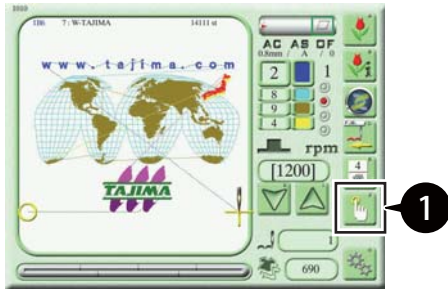

1 Press  on the main screen.

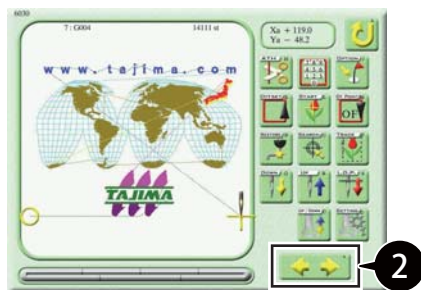

2 Press .

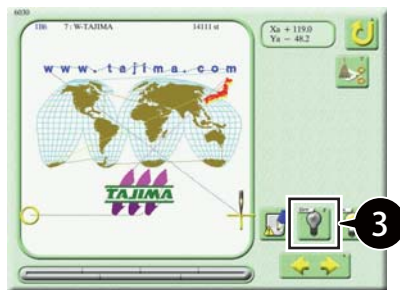

3 Turn ON/OFF the LED lamp set.

 : Turn OFF

 : Turn ON

Chapter 5

Deleting or Saving Designs

1. Deleting Designs

This section describes how to delete designs in the machine memory.

1-1. Deleting a design in the machine memory (one design at a time)

To delete one design at a time, use the following steps.

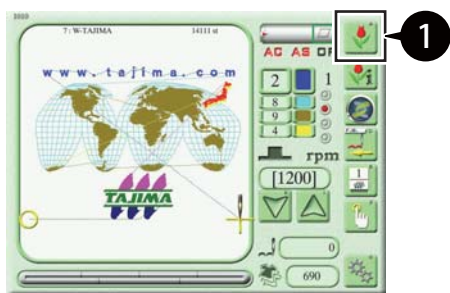

1 Press  on the main screen.

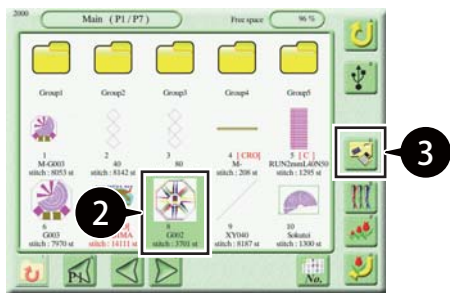

2 Select the design you want to delete.

3 Press .



• Press  to select all the designs.

• Press  to deselect all the designs.

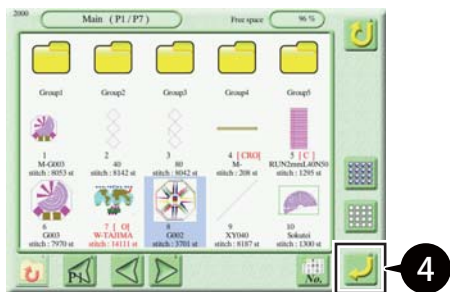

4 Press .



5 Press .



6 Press .

The deletion is performed.



- If you delete the design whose data is set, you cannot continue embroidery.

1-2. Deleting designs in the machine memory (two or more designs at once)

To delete two or more designs at once, use the following steps.

The following example shows how to delete two selected designs at once.



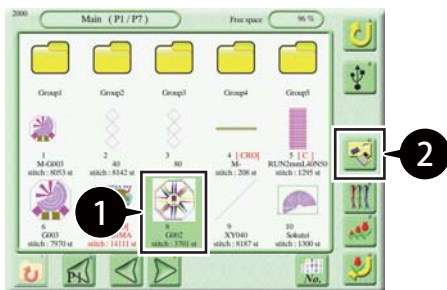

- If the designs you want to delete belong to different layers, delete them for each layer.



1 On the design selection screen, select the first design you want to delete.

2 Press .



- Press  to select all the designs.
- Press  to deselect all the designs.

1. Deleting Designs

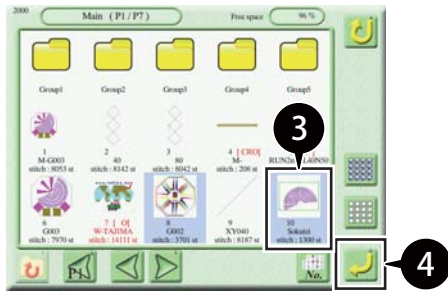

3 Select the second design you want to delete.

4 Press  .



5 Press  .

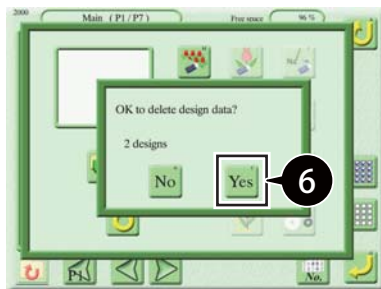

6 Press  .

The deletion is performed.



- If you delete the design whose data is set, you cannot continue embroidery.

1-3. Deleting designs in the USB memory

To delete designs in the USB memory, use the following steps.
The following example shows how to delete two selected designs.



- If the designs you want to delete belong to different layers, delete them for each layer.

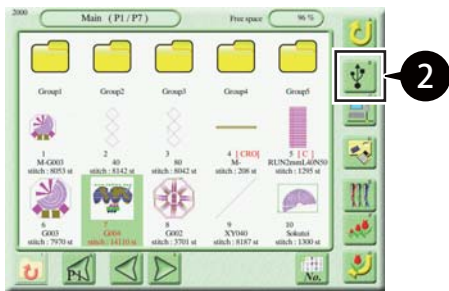

1 Insert a USB memory containing designs into the USB port on the operation panel.

2 Press .

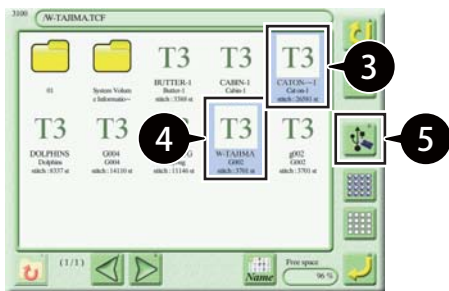

3 Select the first design you want to delete.



- Press  to select all the designs.

- Press  to deselect all the designs.

4 Select the second design you want to delete.

5 Press .

6 Press .

The deletion is performed.

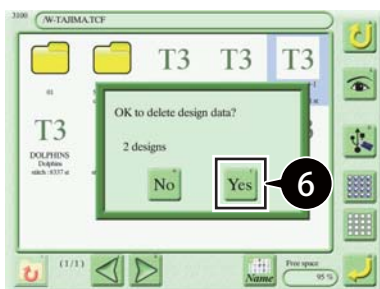

2. Saving Designs

2-1. Saving designs in the USB memory

To save designs from the machine memory to the USB memory, use the following steps. The following example shows how to select two designs and store them as "T3" data in the USB memory.



- This feature is only available if the functional limit level is set to "SEL".

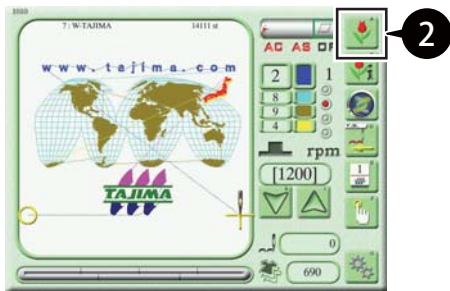

1 Insert a USB memory into the USB port on the operation panel.

2 Press  on the main screen.

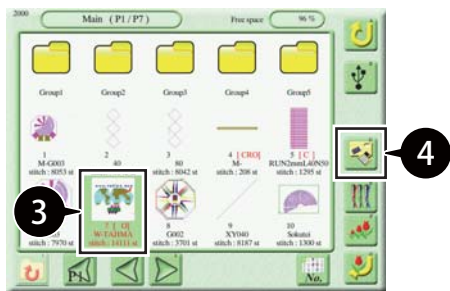

3 Select the first design you want to save.

4 Press .



- Press  to select all the designs.

- Press  to deselect all the designs.

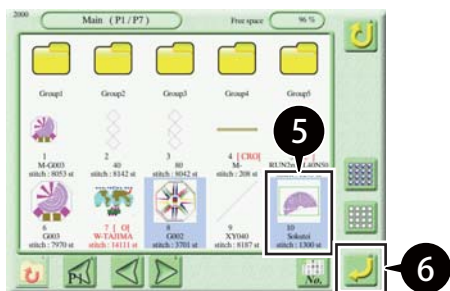

5 Select the second design you want to save.

6 Press .

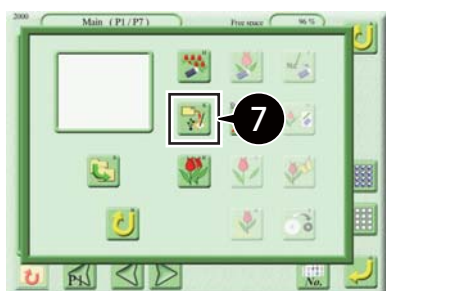

7 Press .



- If you want to save the design without changing the file name, skip to step 9.

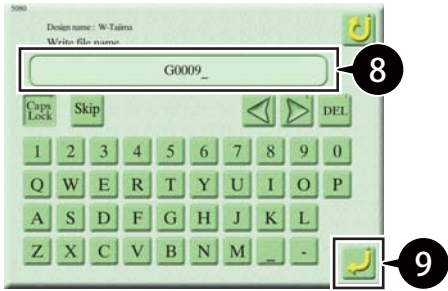

8 Change the file name of the first design you want to save.
(For example, change to "G0009".)



- Enter up to 20 alphanumeric characters. The file name you enter will be displayed on your PC ("G0009.TCF" in this example).

9 Press .

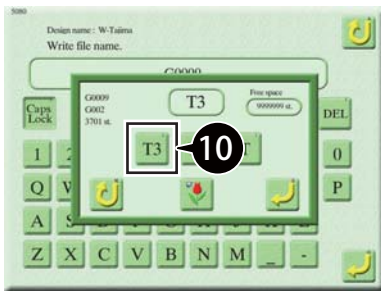

10 Press .



- Usually, select . For more information on the storage format, refer to "Chapter 2 2-1. Saving or Storing designs into the machine memory".

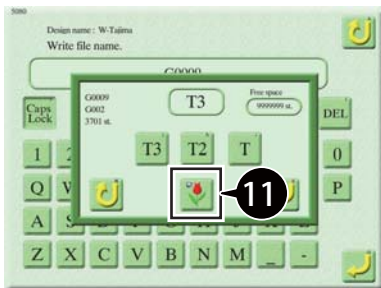

11 Select the storage format.



: Specify the storage format for each design you save.



: Save the selected designs in the same storage format.

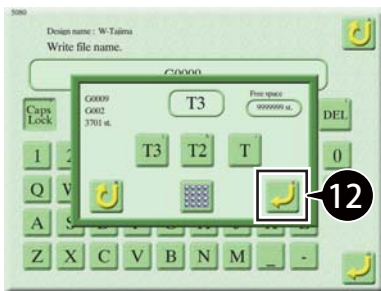

12 Press .



- If you want to save the design without changing the file name, skip to step 14.

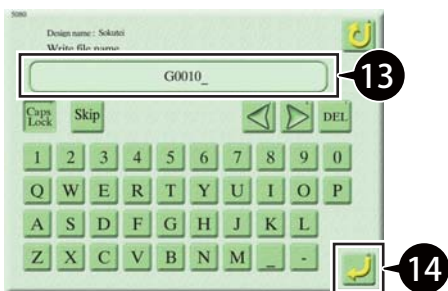

13 Change the file name of the second design you want to save.
(For example, change to "G0009".)

14 Press .

The designs are saved in the USB memory.

■ About the design display on your PC

When you read the designs saved in the USB memory (for example, file name "G0003") into your PC, they are displayed as follows:

Saving format	Display on your PC	Use
T3 (TCF) ^{*1}	G0003.TCF	Data integrating T2 (CT0, DGF, TBF) and CT1 The following conditions are included in CT1. Message S Message E
T2 (TBF) ^{*2}	G0003.CT0	Condition data (color change sequence, start position)
	G0003.DGF	Thumbnail data
	G0003.TBF	Stitch data of TAJIMA binary format
T (DST)	G0003.DST	Stitch data of TAJIMA ternary format

*1: The T3 format consists of the following four sets of data combined into a single file:

TBF (TAJIMA binary format)	CT0 (Condition data)
DGF (Thumbnail data)	CT1 (Message)

*2: The T2 format consists of the following three sets of data but they are not combined into a single file.

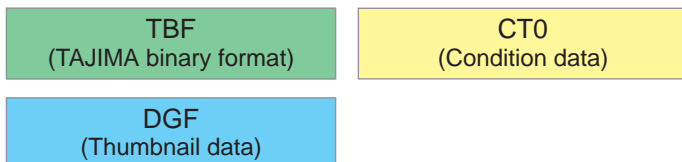

2-2. Changing the design storage location

To move designs to a different storage location in the machine memory, use the following steps. The following example shows how to select two designs and move them to the "Group2" folder.

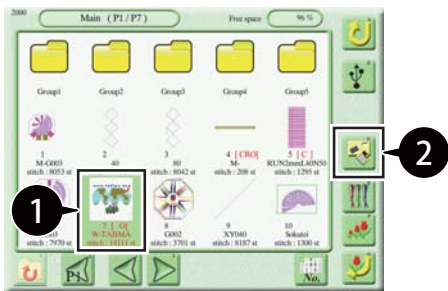

1 On the design selection screen, select the first design you want to move.

2 Press  .



- Press  to select all the designs.

- Press  to deselect all the designs.

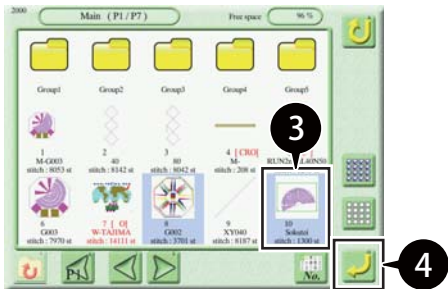

3 Select the second design you want to move.

4 Press  .



5 Press  .

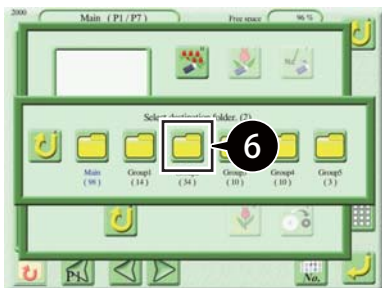

6 Press  "Group2".

The designs are saved in the "Group2" folder.

2-3. Changing a design name

To rename a design saved in the machine memory one by one, use the following steps.

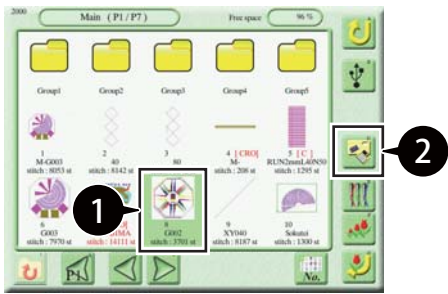

1 Select the design you want to rename on the design selection screen.

2 Press .

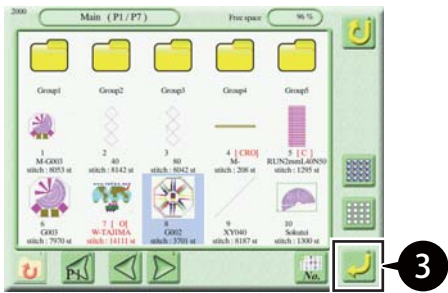

3 Press .



4 Press .

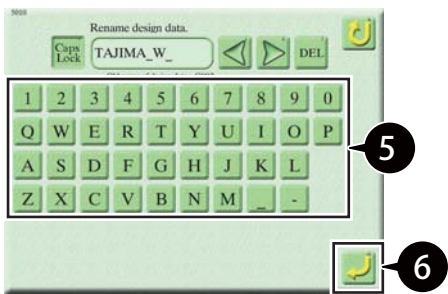

5 Enter the new design name.



- You can enter a design name up to 8 characters long.

6 Press .





The design is renamed.

Chapter 6



Maintenance

1. Precautions for Maintenance

Warning

-  Be sufficiently trained and instructed on how to perform maintenance work such as lubrication and adjustment before actually doing so.
-  Greasing, inspection of drive systems, and repair of the machine must be performed by the distributor or the service personnel assigned and trained by TAJIMA. Failure to observe this may result in injury, electric shock, or other serious accident.
-  Ensure the safety by turning OFF the machine power and removing the power plug from the outlet before starting maintenance work.
-  Upon completion of maintenance work, re-install all the covers you removed. Running the machine with covers removed may result in being caught in the moving parts.

Caution

-  Perform maintenance work periodically. Lack of maintenance may result in early deterioration or failure of parts. Damage arising from lack of maintenance may be excluded from the scope of guarantee.
-  If the machine is not used for a long period, turn ON the power switch in regular intervals. Although each card of the machine has a backup battery, data may be lost in about one month because voltage of the battery will come down gradually due to discharge when the power switch is turned OFF.
-  When you work underneath the machine table, ensure sufficient lighting.

2. Maintenance Item List

Daily maintenance and inspection are important to prevent machine trouble.
Use the following maintenance and inspection items for maintenance plans, etc.

■ Maintenance and inspection items

Frequency	Parts	Maintenance and inspection content
Once per 5 to 6 hours	Rotary hook	Lubrication
Every day	Inside of the cylinder bed	Cleaning
Once/week	Head and its surroundings	Cleaning
	Inside of head	Lubrication
	Drive system	Cleaning
	Presser foot shaft	Cleaning
Once every three months	Inside of head	Greasing
	Each belt in main shaft drive system	Periodic inspection
	X- and Y-axis drive belts	Periodic inspection
	Rotating, sliding section	Periodic inspection
Once every six months	Cylinder bed gear	Greasing

3. Cleaning

Clean accumulated lint and dust, using a commercially available cleaning tool, an air gun, and the supplied brush.

3-1. Inside of the cylinder bed

Frequency: Every day

Manually operating the ATH (automatic thread trimming and holding device)

Open the movable knife of the ATH before cleaning, using the operation panel.

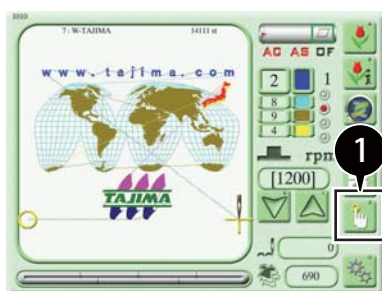

1 Press  on the main screen.

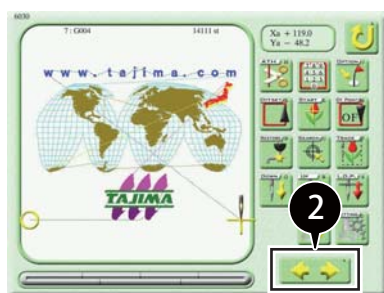

2 Press .

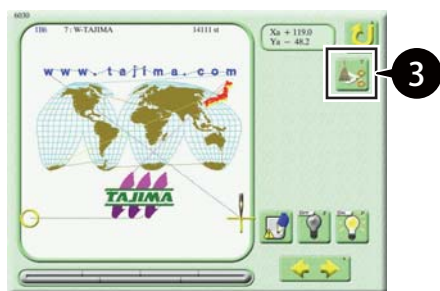

3 Press .



4 Press .

The movable knife of the ATH opens.

Cleaning of the interior

Use a brush or air gun and clean the interior of the cylinder bed.

Warning

! To prevent an accident due to an unexpected startup, be sure to turn off the power before accessing the machine.



- The open movable knife automatically closes when you turn ON the power after cleaning.

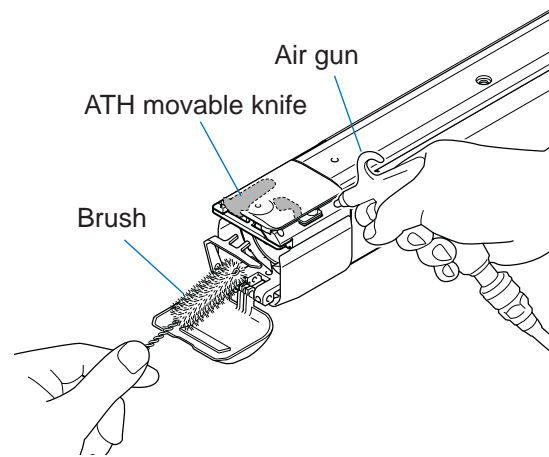

3-2. Head and its surroundings

Frequency: Once a week

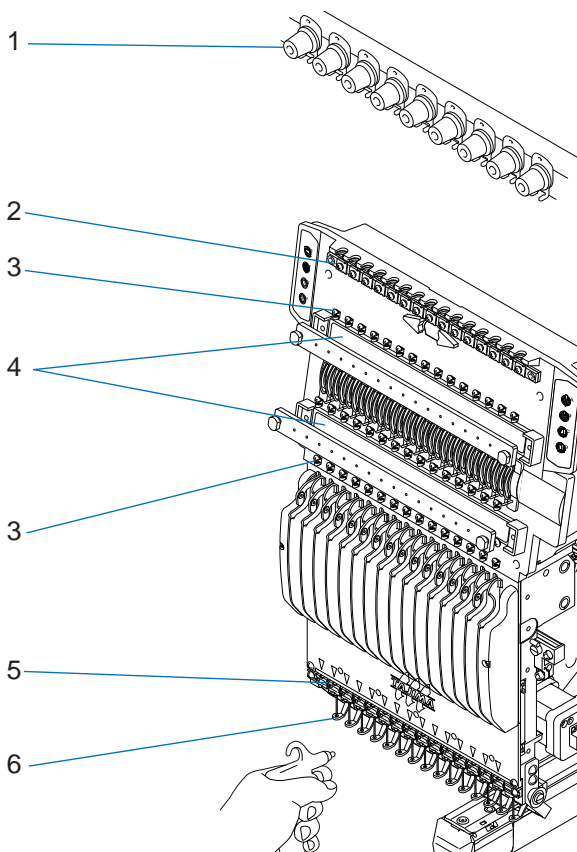

	Cleaning area
1	First thread tension regulator
2	Thread presser
3	Thread course
4	Disk bar
5	Upper thread lock
6	Presser foot

3-3. X-axis drive system, Y-axis drive system

Frequency: Once a week

Using the air gun, air-blow the interior from the slits of the drive system.

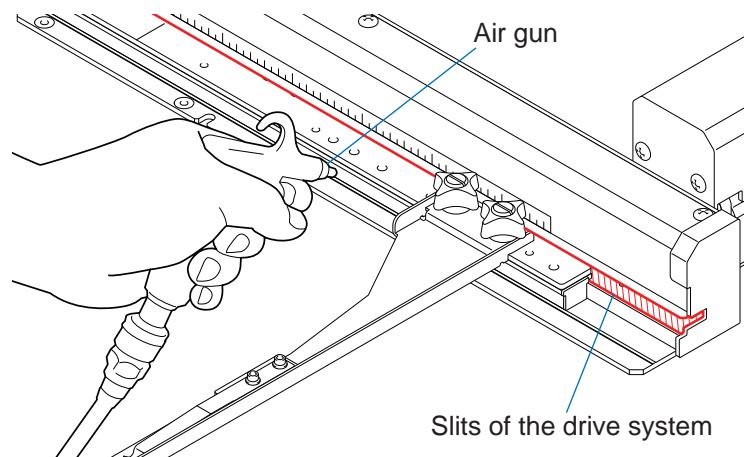

3-4. Presser foot shaft

Frequency: Twice a week

Thread and dust may adhere and movement of the presser foot shaft may be impaired. Use an appropriate tool, such as an air gun and clean the presser foot shaft.

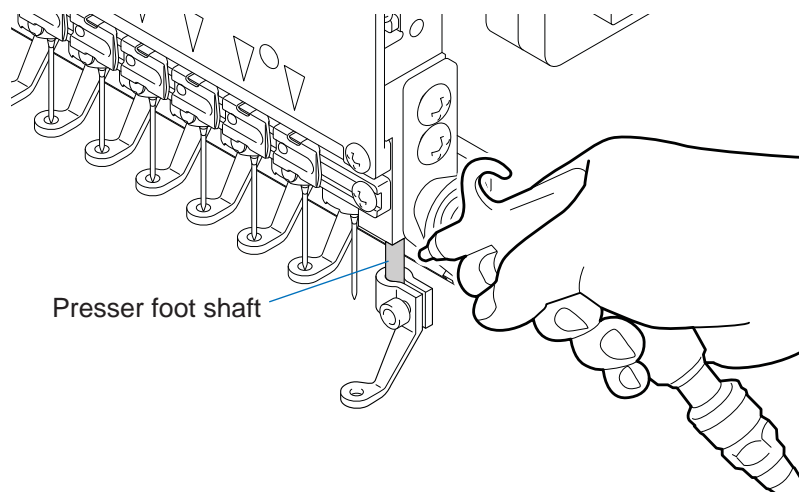

Press  on the tension base to lower the presser foot, and clean the shaft.





4. Lubrication

Perform lubrication using the supplied oiler.

Warning

-  Maintenance work should be performed by the personnel who is trained adequately.
-  To prevent an accident due to an unexpected startup, be sure to turn off the power before accessing the machine.

Caution

-  Use only TAJIMA's genuine TF oil or equivalent (Viscosity grade = VG20).
-  Pour a few drops of oil for lubrication. Using too much oil may cause the oil to drip or scatter, possibly dirtying or staining the fabric or thread. Wipe off excess oil with a cloth.

4-1. Rotary hook

Frequency: Once per 5 to 6 hours



- To lubricate a lubrication hole, attach the nozzle (accessory) to the tip of the oiler.

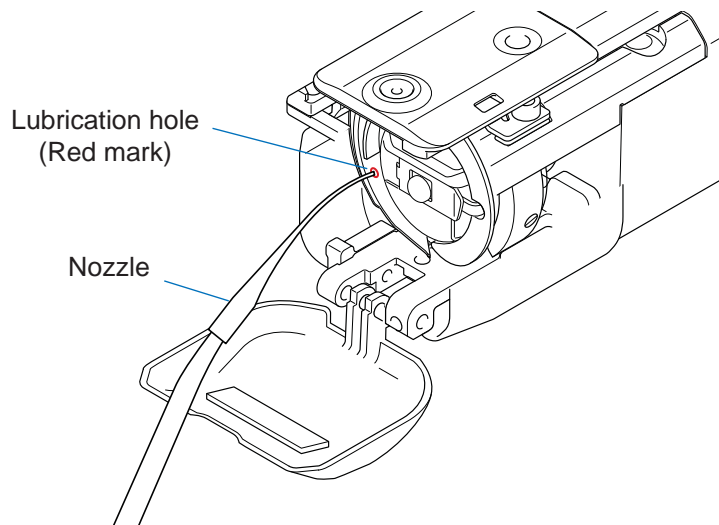

4-2. Inside of head

Frequency: Once a week

Internal lubrication

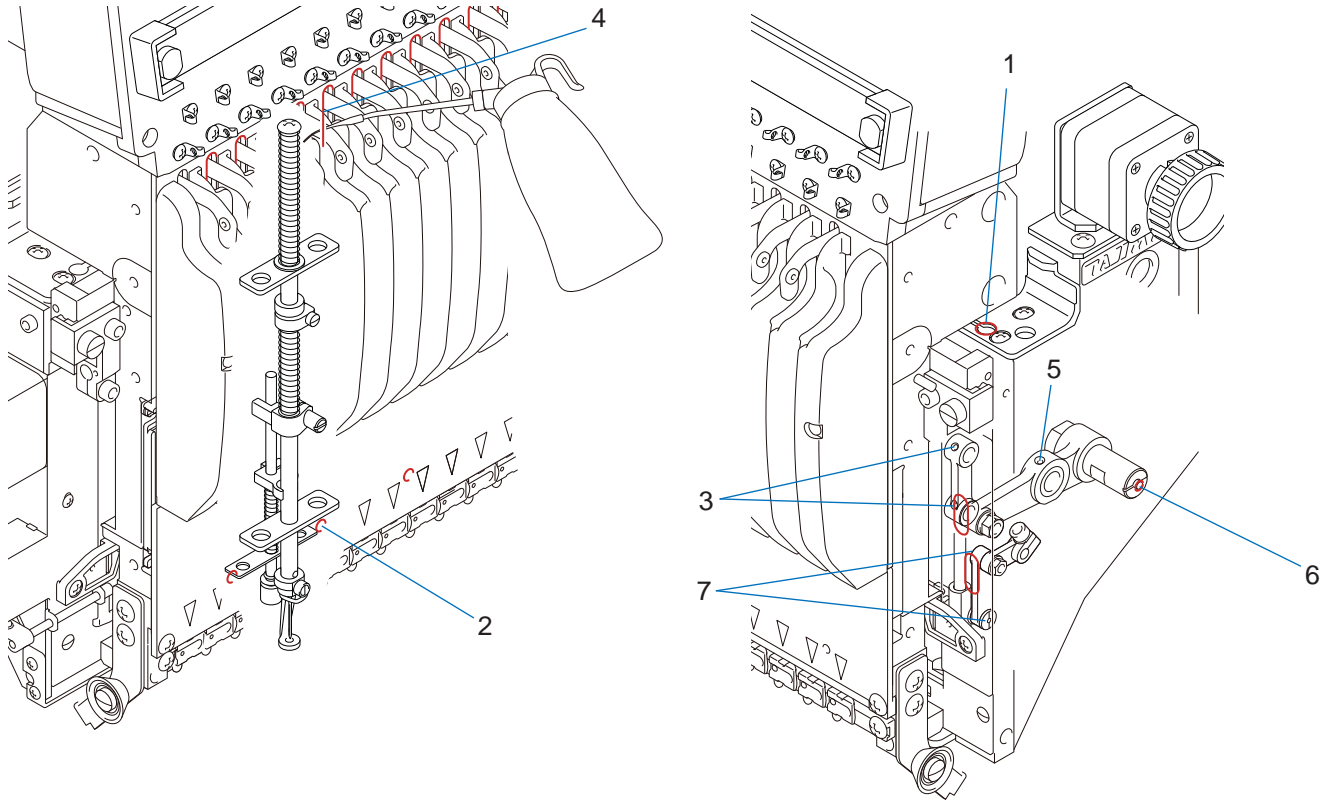

	Lubricating spot
1	Needle bar drive shaft
2	Needle bar and presser foot shaft (spots indicated by red marks)
3	Lubrication hole of connecting part
4	Needle bar (all needles)
5	Lubrication hole of needle bar lever
6	Lubrication hole of stepped pin
7	Drive system of presser foot

5. Greasing

This section contains information intended for use by service personnel assigned and trained by TAJIMA.

Warning

- ! Greasing must be performed by the distributor or the service personnel assigned and trained by TAJIMA.
- ! To prevent an accident due to an unexpected startup, be sure to turn off the power before accessing the machine.

Caution

- ! Use a grease specified (described below) by TAJIMA or equivalent to keep the lubricity inside of the head normally. Use of grease other than above could cause trouble due to deterioration of the lubricity.

Manufacturer of grease specified by TAJIMA: NIPPON GREASE Co., Ltd.				
Parts to be greased	Part name	Item No.	Base oil	Thickener
Cylinder bed gear	KING STAR EP NO.2: 400G	750103004000	Refined mineral oil (about 75%)	Lithium soap (about 15%)
Inside of head	NIG LUBE PG: 300ML	750104001000	Olefinic synthetic oil	Lithium soap



- For questions regarding greasing and how to obtain grease, consult the distributor.

5-1. Cylinder bed gear

Frequency: Once every six months

Grease the cylinder bed gears, using grease specified by TAJIMA.

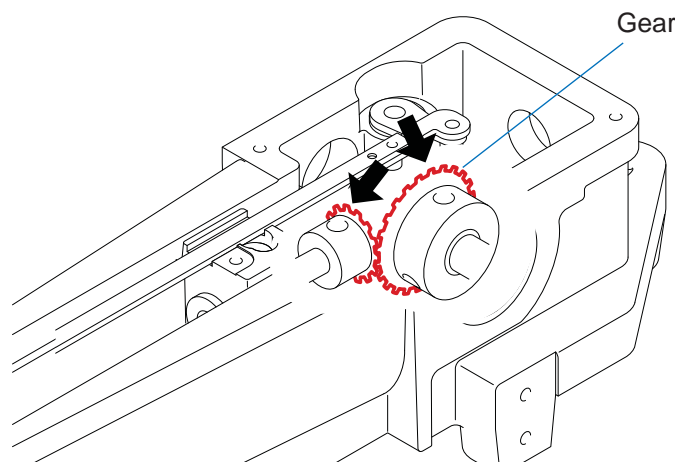

5-2. Inside of head

Frequency: Once every three months

Grease up the moving parts of the head, using grease specified by TAJIMA.

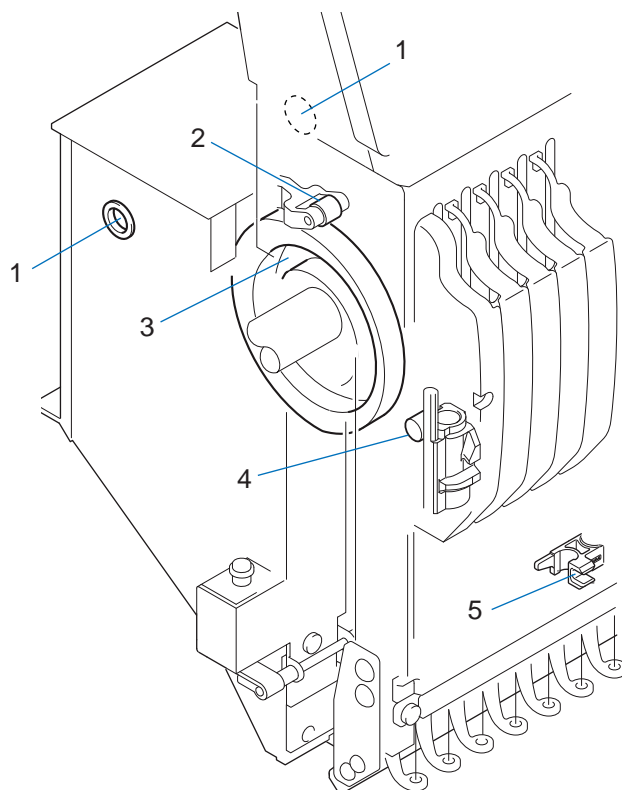

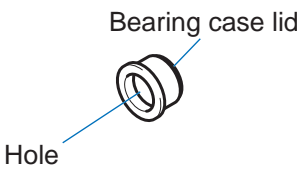
Greasing spot	
1	Take-up lever shaft holder Inject grease from the hole in the bearing case lid, using a syringe. 
2	Take-up lever drive lever roller
3	Presser foot cam
4	Take-up lever cam
5	Presser foot reciprocator



6. Inspection and Repair

This section contains information intended for use by service personnel assigned and trained by TAJIMA.

6-1. Inspection of drive systems and sliding parts

Frequency: Once every three months



Warning

-  Inspection of drive systems must be performed by the distributor or the service personnel assigned and trained by TAJIMA.
-  Before the work, turn OFF the power and remove the power plug from the outlet. Some circuits are supplied with voltage even after you remove the power plug. Wait until they are completely discharged (for at least 4 minutes), and then start the work.

Inspection point	Action	Inspection cycle
Attaching of each type of cover	Attach all covers.	When starting work
Setting condition of embroidery thread	Set the thread correctly.	
Check breakage and/or bent of needle.	Replace the needle.	
Lubricating condition of each section	Lubricate.	
Belt tension (Main shaft and X/Y drive system)	Please consult the distributor.	Once every three months

6-2. Repair

Warning

-  Repair of the machine must be performed by the distributor or the service personnel assigned and trained by TAJIMA.
-  Do not change the specification nor modify the parts of the machine without due consultation with TAJIMA. Such modification may risk the operational safety.
-  Before the work, turn OFF the power and remove the power plug from the outlet. Some circuits are supplied with voltage even after you remove the power plug. Wait until they are completely discharged (for at least 4 minutes), and then start the work.

Caution

-  For the machine repairs, use TAJIMA genuine parts for replacement.

7. Checking and Adjustment

This chapter describes how to check the height of the needle bar lower dead point and how to adjust the presser foot height.

Warning

- ! Maintenance work should be performed by the personnel who is trained adequately.
- ! To prevent an accident due to an unexpected startup, be sure to turn off the power before accessing the machine.

Caution

- ! Take care to prevent the needle from sticking in your finger.

7-1. Checking the needle bar lower dead point

The machine is adjusted by default so that the needle bar reaches the lower dead point (the lowest point) when the main shaft angle is 178° . If you often encounter problems such as the frequent occurrence of thread or needle breakages or imperfect finish of sewing, the needle bar lower dead point may be incorrect. Check the status using the supplied lower dead point gauge.

The following example shows how to check the first needle bar.

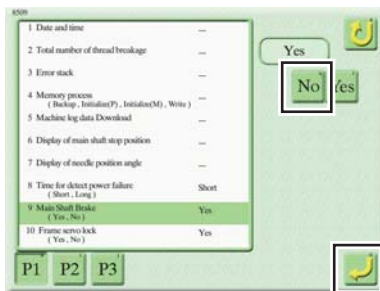

- 1 Set the needle position to the first needle by operating the operation panel.
- 2 Set parameter "85. Machine Adjustment: 9. Main shaft brake" to "No".

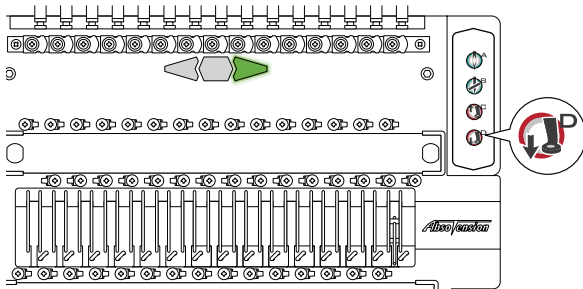

- 3 Press  on the tension base twice to set the presser foot to the lower dead point.

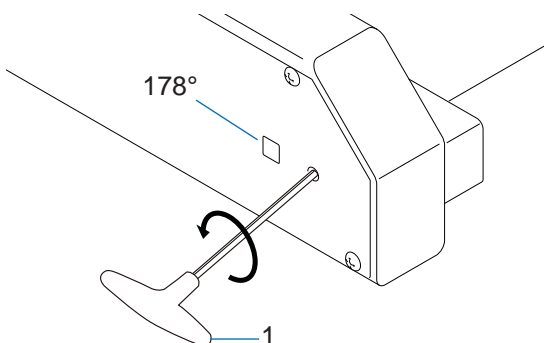

- 4 Insert hexagon wrench 1 (M6) into the left-hand side of the machine and turn the hexagon wrench counterclockwise to set the main shaft angle before 178° (the needle bar lower dead point).

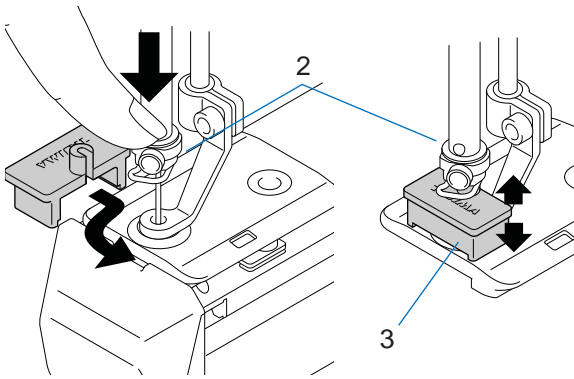

- 5 Lower needle clamp 2 by finger and lower the needle bar.
- 6 Insert lower dead point gauge 3 into needle clamp 2 and turn hexagon wrench 1 slowly to 178°.
- 7 Check that lower dead point gauge 3 has no play.

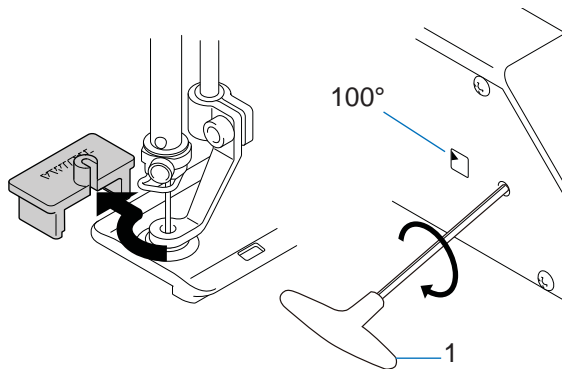

- 8 Turn hexagon wrench 1 a little clockwise to remove lower dead point gauge 3 when the needle bar is raised.
- 9 Turn hexagon wrench 1 clockwise to set the main shaft angle to 100° (the stop position).

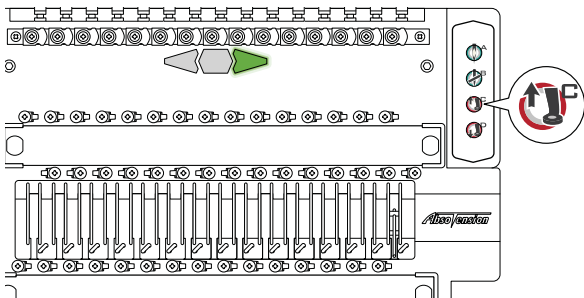

- 10 Press on the tension base to return the presser foot.

7-2. Adjusting the stroke amount of the thread take-up spring

When you want to tighten or loosen the thread tightening, adjust the stroke amount of the thread take-up spring inside the middle thread guide.

■ Removing the middle thread guide

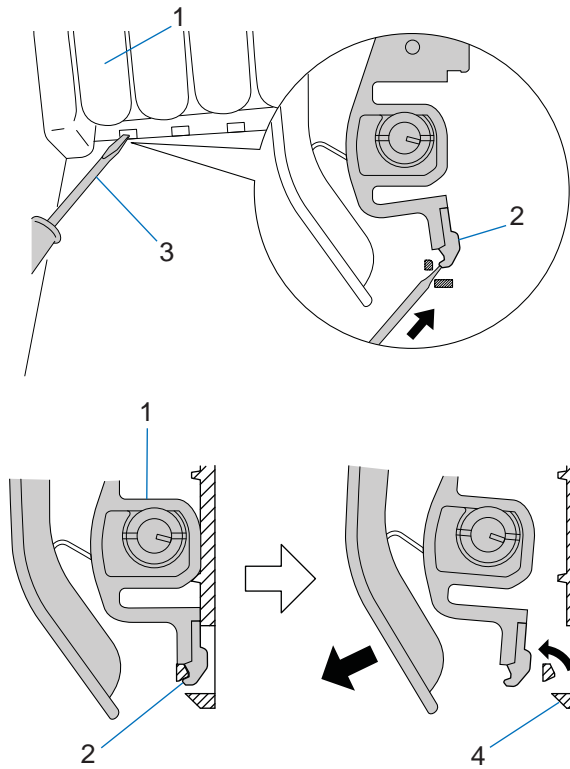

- 1 Remove middle thread guide 1 from top cover 4 by pushing pawl 2 with something like a stick with a sharp tip 3 and pull it toward yourself.

1

2

3

4

5

6

7

8

■ Stroke amount adjustment

Adjust the thread take-up spring stroke amount by turning the spring shaft using a coin or the like inserted into its groove.

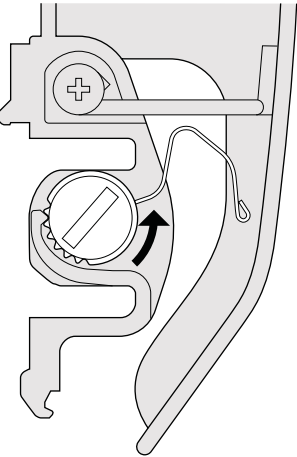
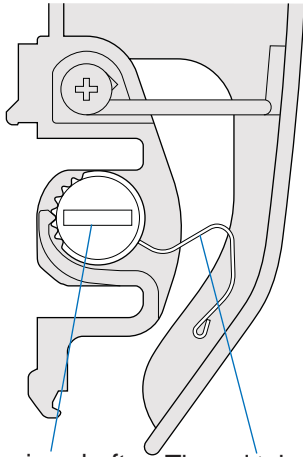
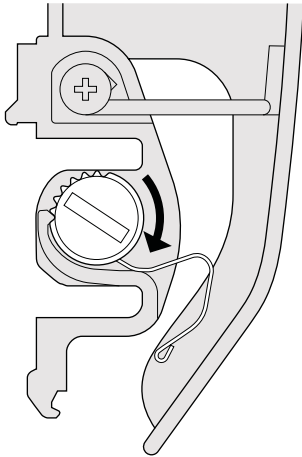
Thread tightening	Getting weak	Standard	Getting strong
Stroke	Minimum	Standard	Maximum
Maximum adjustment	Three levels in the counterclockwise direction	Position by factory default	Two levels in the clockwise direction
Condition		 Spring shaft groove Thread take-up spring	

■ Installing the middle thread guide

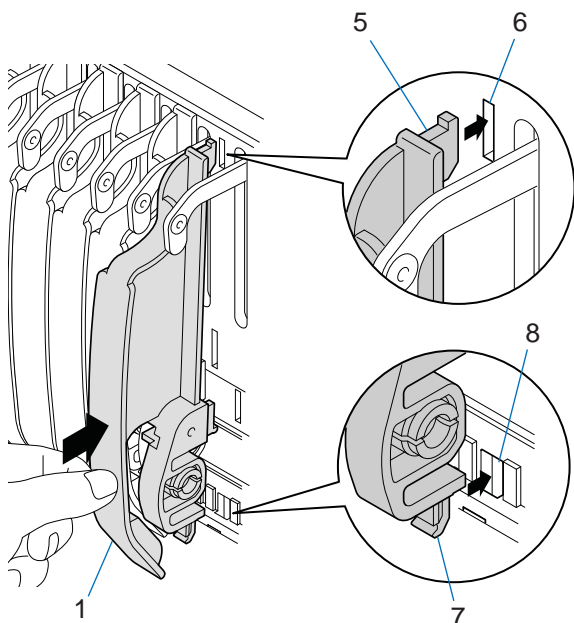

- 1 Insert upper pawl 5 of middle thread guide 1 into slit 6 and fit locking pawl 7 into hole 8 by pushing it up by finger.
- 2 Push middle thread guide 1 securely to fit until it clicks into place.

8. Others

This section contains information intended for use by service personnel assigned and trained by TAJIMA. After you remove the tension base cover for such purposes as replacing a card, fasten the harness with a coated clip and pull it out so that the mark tube is exposed outside from the grommet.

⚠ Caution

! Failure to observe this precaution may cause the harness to contact the card, possibly destroying the card.

8-1. Precautions to take when installing the tension base cover

[Fasten with a coated clip]

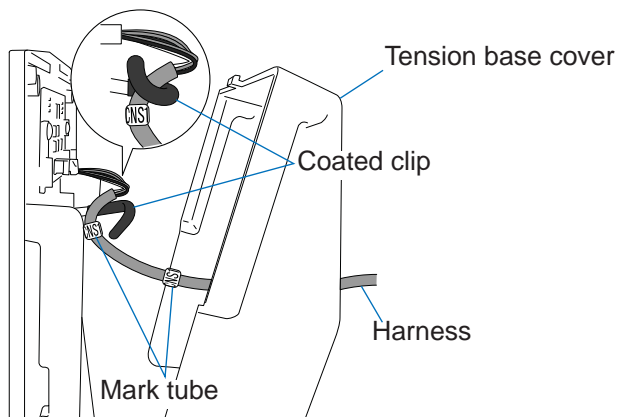

[Pull out the mark tube]

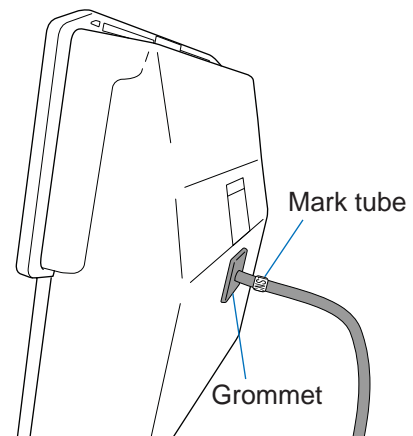

Chapter 7

Troubleshooting

1. Message Screen

When the machine stops during operation, a message screen appears on the operation panel. Perform troubleshooting based on the code No. and message displayed on the message screen.

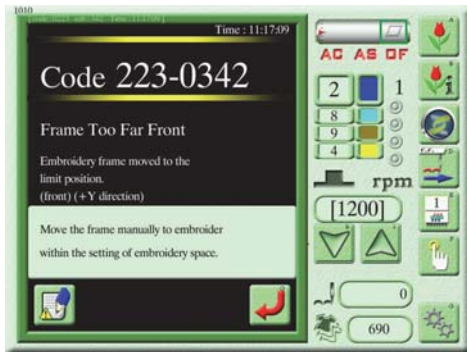

Warning

Code numbers affixed with * in the following table must be coped with by the distributor or the service personnel assigned and trained by TAJIMA. Failure to observe this may result in injury, electric shock, or other serious accident.

Cord	Stop factor	Corrective action
1B1	Stop by frame stepping code This stop is not caused by an error.	Perform "Start operation" or "Frame Back/Forward operation", or press any operation key to continue the operation of machine.
1B2	Stop by color change code This stop is not caused by an error.	
1B3	Stop by end code This stop is not caused by an error.	
1B4	Stop by thread trimming code This stop is not caused by an error.	
1B5	Stop by sequin code This stop is not caused by an error.	
1B6	Stop by automatic arbitrary offset code This stop is not caused by an error.	Perform "Start operation" or "Frame Back/Forward operation", or press any operation key to continue the operation of machine.
1B8	Stop by temporary stop code This stop is not caused by an error.	
1C1	Stop by the stop button Machine stopped by operator's operation.	Continue the operation of the machine if needed. Turning OFF the main power with the code 1C1 displayed on the message screen may render it impossible to continue embroidery.
1C3	Halt by input of external stop signal Machine stopped by the stop signal from an external device.	Continue the operation of the machine if needed.

Cord	Stop factor	Corrective action
1C4	Stop by switch operation of tension base The machine stopped by the change of tension base switch from clutch to normal during embroidery by ESQ-C.	Perform "Start operation" to continue the operation of machine if needed.
1D1	Halt at Frame Back start point Machine stopped by the halt setting at the start point of embroidery after Frame Back operation.	Perform "Start operation" to continue the embroidery.
1D2	Preset Halt Machine stopped by the preset halt setting.	Reset the machine by pressing the reset button. Perform "Start operation" to continue the embroidery.
1D3	Stop for material processing Machine stopped by automatic stop setting for material processing.	Cut or trim the material as needed or otherwise process the material as appropriate. Continue the operation of the machine if needed.
211-01	Fixed position signal error Machine stopped at other than the fixed position.	Return the main shaft to the fixed position. Adjust the encoder/encoder Z signal.
212	In the state of needle bar lowered Needle bar is descending.	Move needle bar up and operate the machine.
213	Lower dead point error Machine is stopping at the lower dead point.	Move needle bar up and operate the machine.
221	+X axis limit signal detection The embroidery frame moved to the travel limit position (left). (+X direction)	Move the frame manually to embroider within the setting of embroidery space.
222	-X axis limit signal detection The embroidery frame moved to the travel limit position (right). (-X direction)	Move the frame manually to embroider within the setting of embroidery space.
223	+Y axis limit signal detection The embroidery frame moved to the travel limit position (front). (+Y direction)	Move the frame manually to embroider within the setting of embroidery space.
224	-Y axis limit signal detection The embroidery frame moved to the travel limit position (rear). (-Y direction)	Move the frame manually to embroider within the setting of embroidery space.
225	Design size too large Design does not fit within the embroidery space due to the present start position of design.	Move the frame manually to embroider within the setting of embroidery space.
*258	Upper dead point sensor error Upper dead point sensor error detected.	Check/replace the upper dead point sensor for ESQ-C.
*259	Lower dead point sensor error Lower dead point sensor error detected.	Check/replace the lower dead point sensor for ESQ-C.
*25A	Sequin color change sensor failure Color change sensor error detected.	Check/replace the color change sensor for ESQ-C.
281	Color changing error The target needle position is not detected even if 8 seconds have passed since the start of color change.	Correct the needle position. Adjust or replace the potentiometer.
291	Stop by detecting thread breakage Machine detected upper thread breakage.	Check the upper and under threads. Check or replace the tension base card.

1. Message Screen

Cord	Stop factor	Corrective action
293	Under thread break Machine detected under thread breakage.	Check the under thread. Check or replace the tension base card.
294	Running out of material detected Machine detected running out of sequin material.	Check/replace Sequin material.
*2A1	Thread trimming position adjustment error Adjustment time of thread trimming position was exceeded.	Return the ATH movable knife to the fixed position. Check or replace the thread trimming motor or the thread trimming motor encoder.
2B2	TAJIMA Complement error Complement error detected in TAJIMA data.	The same values (+ and -) of the design data are valid at the same time. Correct the design data.
2B3	Data found in end code Data is found in end code.	Delete "X/Y travel amount of the end code" of the design data.
2B4	Function code error Function code error occurred.	There is a function code that is not defined. Correct the design data.
2B7	Data set incomplete Data set is not completed.	Operate the machine after setting the data of embroidery design.
2B8	Data pre-reading buffer error Output data cannot be prepared.	During operation: decrease the number of revolutions. During Frame Forward: do not perform the Frame Forward any more.
*2B9	Memory write error Cannot write data into memory.	Check and replace CPU card/operation panel.
2BA	Memory capacity exceeded Free space of memory is insufficient.	Increase the free space of memory by deleting unnecessary designs in the designs registered in the memory (after taking the backup if needed).
2BB	Frame Back limit over Frame Back exceeded available range.	Do not perform Frame Back any more.
2BC	Design No. error Design No. is not found. Cannot edit the design because the data is being set. The design is not registered in memory.	Set the data for the same or other design and then edit the desired design. Register designs in the memory.
2BE	Incorrect function code segment Start/end codes are not registered in a pair for the function which has start/end.	Modify/set the design again so that the codes of start/end become a pair.
*2BF	Memory read error Memory cannot be read.	Check/replace the operation panel.
2C1	Insufficient program setting	Operate after coming out of parameter setting screen/ the other setting screens/manual operation screen.
2C6	Operation of the machine was performed during working of bobbin changer.	Do not operate the machine during working of bobbin changer.
2C7	Password requested Password is required. The password you entered is not valid.	Input the password.
2CE	Stop by safety device Machine was stopped by the stop signal from the safety device.	After confirming safety, continue the operation of machine if needed.

Cord	Stop factor	Corrective action
2E2	Air pressure error Air pressure has become lower than the standard level.	Check/adjust the pressure of air supplying.
2E3	Power failure during operation The power supply was shut off during main shaft operation.	Turn ON the main power and perform the operation of power resume.
*311-01	Encoder A signal error	Check the encoder signal lines. Check the main shaft driver for excitation.
*312-01	Encoder Z signal error	Check the encoder signal lines.
*314	Main shaft revolution error	After checking around the rotary hook and the main shaft, remove the factor that the main shaft can not rotate.
*316-01	Main shaft motor error	Turn OFF/ON the main power. Check or replace the main shaft motor/IDU amp.
*321-01	Frame driver irregular signal	Decrease the number of the main shaft revolutions. Check or replace the X/Y axis driver card or the frame motor.
*331	Abnormal signal of bobbin changer has been detected.	Operate the bobbin changer manually after resetting the error, and check/adjust the place where motion error occurred.
*352	Sequin device IV driver error	Check/replace Head card C.
*353	ESQ-C driver error	Check/replace Head card A and C.
*361-04	Jump Driver signal error	Turn OFF/ON the main power. Decrease the number of the main shaft revolutions. Check or replace the Head card A.
*382-01	Time to move to target position	Check/replace the color change motor/encoder and potentiometer (needle position sensor).
*383-01	Needle position error	Move the needle bar position into the setting range. Check or replace the potentiometer (needle position sensor) or the color change encoder.
*384	One-turn signal is not detected	Check/replace the photo interrupter (1-rotation sensor) and color change encoder.
*3A1-01	ATH Driver signal error	Turn OFF/ON the main power. Check or replace the thread trimming motor or the controller card.
*3A6	ATH Movable Knife Open	Check the position of ATH movable knife.
3AB	ATH thread separation error	Set the tension base switch at the detected head to the top and make LED lit green. Then press the reset key on the operation panel or start by the bar switch.
3AC	ATH Skip stitch error	
*3B6	Communication error	Check or replace the driver card.
3BE-**	Network communication error	Check the network connection settings. Turn OFF/ON the machine and the connected devices such as DG/ML. Check the connection cable.
*3C1	Start/Stop switch error	Check or replace the connector/connection terminal/limit switch. Turn OFF/ON the main power.

1. Message Screen

Cord	Stop factor	Corrective action
*3C2-01	Frame travel key error	Check or replace the frame travel switch. Turn OFF/ON the main power.
*3D1	Battery signal error	Charge/replace the battery of the operation panel.
*3D2	Battery signal error	Charge/replace the battery of CPU card.
*3D9	Fan Motor error	Replace the fan motor for the controller box.
*3DA	Permanent Counter error	Check/replace the connection of permanent counter.
*3DC	Memory device error	Turn OFF/ON the main power. Install the system software. Check or replace the CPU card.
*3DD-**	System installation error	Press the reset button. Then press the Retry button to reinstall the system. Turn OFF/ON the main power and reinstall the system. Check or replace the CPU card.
5C3	Sequin device twin type setting error	Check/change the parameter setting of sequin device on operation panel.
5C6	General external device is operating.	Do not operate the machine during the operation of general external device.
*6B5-**	Communication error	Turn OFF/ON the main power. Install the system software. Check or replace the related cards.
*6D4	SHT connection error	Connect the harness for SHT control.
OIL	Preset Halt Machine stopped by the preset halt (Lubrication) setting.	After lubricating the necessary spots, reset the machine by pressing the reset button. Perform "Start operation" to continue the embroidery.
B01	Formatting error The memory media is formatted incorrectly. Cannot read or write the data.	After taking the backup, format the memory media. Use new memory media.
B03	Write protect The memory media is write-protected.	After cancelling the write-protection for memory media, perform the writing operation.
B04	Empty media error Media is not inserted.	Insert memory media.
BC1	Unregistered design No. Design No. is not found.	Perform the selection of design again.
BC3	Disk file error This memory media cannot be read.	After taking the backup, format the memory media. Use new memory media.
BC4	Verify error Abnormal Stitch Data found on Media.	Perform writing again.
BC5	Memory capacity insufficient error	Replace with a memory media with enough remaining capacity. Then press the reset button to continue the operation.

2. When the Machine Does not Sew Well

If the machine does not sew well, investigate the cause with reference to the following.

If the cause is unknown or the problem recurs, consult the distributor.

2-1. Frequent thread breakages

Cause	Troubleshooting
Improper thread tension	Adjust the friction. Upper thread = 120 to 140 g, under thread = 20 to 30 g
Poor thread flow	Use silicone.
Direction of needle is bad or needle bents.	Adjust to face to the front or to the right a bit. Replace the needle.
Applique glue is stuck on needle.	Remove adhered glue.
Lint, run-out of oil of rotary hook	Clean and lubricate.
Numerous tiny stitches of 0.5 mm or less in the design	Remove tiny stitch(es).
The fabric is lifted too much against the needle plate. The fabric touches the needle plate too much.	Replace the clips. Stretch the fabric again so that it touches needle plate lightly.
Run-out of oil of needle bar	Lubricate.
There is a scratch on the thread course and /or rotary hook.	Grind a scratch with sandpaper etc. Replace the rotary hook or the thread course.
Bad height of presser foot	Perform adjustment so that height fits to fabric/material.
The combination of frame drive timing and embroidery condition is inappropriate.	Change setting.

2-2. Needle breaks

Cause	Troubleshooting
Improper thread tension	Adjust the friction. Upper thread = 120 to 140 g, under thread = 20 to 30 g
Density of design data is very high	Correct design data. Delete unnecessary underlay stitching.
The material is too thick or hard.	Use material suitable for embroidery.
Bobbin is deformed and the needle touches it.	Replace the bobbin.
Deterioration of needle, mis-matching to embroidery condition	Replace the needle. Use needle that fits to condition.
Vibration of the machine is big.	Center support is applied too much. Tighten the support by hand. Adjust leveling.
The combination of frame drive timing and embroidery condition is inappropriate.	Change setting.

2-3. Embroidery results not good

Cause	Troubleshooting
Improper thread tension	Adjust the friction. Upper thread = 120 to 140 g, under thread = 20 to 30 g
Poor thread flow	Use silicone.
Density of design data does not match with material and/or thread.	Correct design data.
Bad frame attaching and fixing of the fabric	Attach the frame correctly. Fix the fabric firmly.
The combination of thread, needle and/or the size of needle plate is inappropriate to the embroidery condition.	Make combination that fits to design/material.
R.P.M. is too high.	Decrease R.P.M.
The combination of frame drive timing and embroidery condition is inappropriate.	Change setting.

3. Power Resume after Power Failure

If the power is shut down due to power failure or emergency stop during embroidery, turn ON the power and perform power resume.

⚠ Caution

- ⊘ Do not put your hands on the table when you operate the machine because doing so may cause your finger or hand to be injured when the needle bar or frame moves.

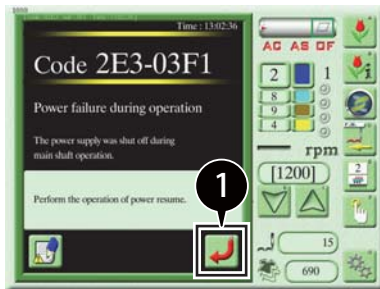

- 1 Press  on the message screen.

The power resume method selection screen appears.

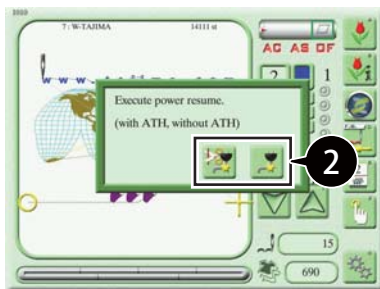

- 2 Select the power resume method.



: Perform power resume after trimming the thread.



: Perform power resume without trimming the thread.



- When you perform power resume, the machine checks the absolute origin and the frame moves to a position several stitches back from the position where it was when the power was turned OFF.

4. Obtaining Log Data

Machine operation history and communication history are recorded as machine logs. If the distributor requests you to provide log data for the purpose of investigating the cause of trouble, save the log data in a USB memory.

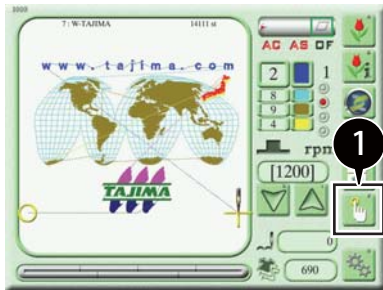

1 Insert the USB memory into the USB port of the operation panel and then press  on the main screen.

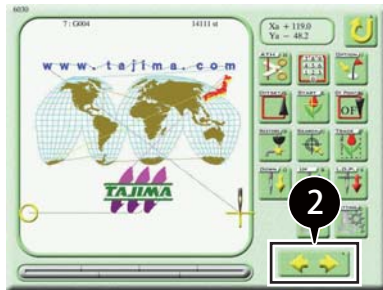

2 Press .

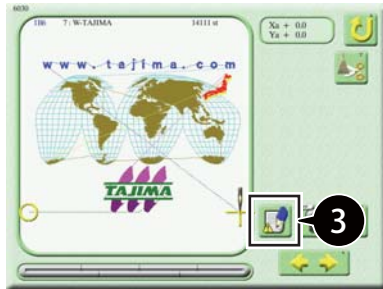

3 Press .



4 Press . The log data saved on the CFast card in the operation panel and the log data you have obtained will be saved on the USB memory.



- Pressing  saves log information on the CFast card in the operation panel up to 50 times. After exceeding 50 times, existing log information will be overwritten.

5 Remove the USB memory from the USB port.

Chapter 8

Appendix

1. Specifications

1-1. Electrical specifications

Rated current	1.3 A (120 V)
Max. power	160 W
Apparent power	180 VA
Allowable voltage range	Within $\pm 10\%$ of the rated voltage
Frequency	50/60 Hz
Insulated resistance	10 M ohms or greater (500 megger insulation tester)

1-2. Ambient noise level

The ambient noise level of the machine is less than 85 dB. Measuring conditions are as follows.

Measuring ambience	Refer to the right illustration.
Measuring position	Measured at position A at a height of 1.6 m from the floor and a distance of 1.5 m from the needle locating position
Working machine condition	Fabric is stretched on the border frame, and embroidered a design which has 4 mm width.
R.P.M.	Maximum number of revolutions of machine
Measuring instrument	Compliant to IEC61672-1: 2002 Class 1

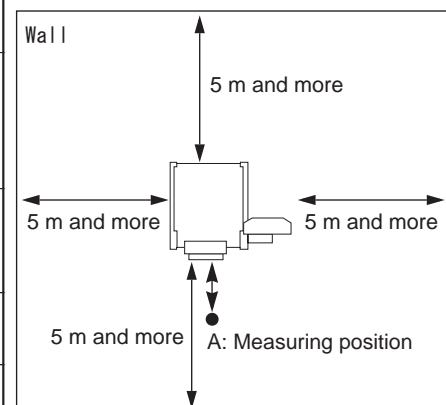

1-3. Machine weight

Machine weight is described on the spec. plate.

2. Terminology

The following terms are common to all the models. They may not apply to some models.

<A>

Absolute origin

An anchoring point to calculate the current frame position (Xa + 0.0, Ya + 0.0).

ATH

The abbreviation of Automatic Thread Trimming and Holding Device.

Auto Jump

To make a stitch divided into two stitches as less than setting value automatically when its stitch length exceeds the setting value. It is effective to prevent the slippage of the frame and the displacement of the design.

Backlash

A play (gap) generated at the drive system and/or around the frame by shock when a stitch returns (when frame drive is reversed). It may affect embroidery finish.

<C>

Cleanup

To remove tiny stitches included in design data to make before and after stitches absorb it. It has an effect on decreasing thread breakages.

Condition data (CT0)

Embroidery condition included in the design (needle bar selection, data conversion, repeat, start position, automatic offset).

CT0

File including the information of needle bar selection and start position. It is necessary to handle TBF, CT0, and DGF as a set on a personal computer.

<D>

Data mode

Saving format of design (T, T2, T3).

Data set

To set the design data in the memory of the machine to start the machine.

D-axis

Driving shaft to rotate sewing needle and nipple (TCMX series).

DG by Pulse

Embroidery design creation software developed by Pulse Microsystems Ltd. It provides the ability to quickly convert vector data to stitches. It also provides the ability to send designs to the machine by connecting DG by Pulse to the machine via LAN.

DGF

File that indicates design image. It is necessary to handle TBF, CT0, and DGF as a set on a personal computer.

Driver

Control card to make the frame or main shaft drive. X-axis driver, Y-axis driver, main shaft driver, etc. are included.

DST

Stitch data for Tajima ternary format. Data saving format is T.

<E>

Excitation

To keep frame motor drive. It is not possible to move the frame by hand during excitation.

<F>**Fine stitch**

Fine stitch as a factor causing thread breakage.
Stitch of which the stitch length is 0.5 mm or less.

Fixed pitch movement

Horizontal frame travel to the neighboring head by head interval.

Fixed position

Angle of the main shaft at which the main shaft motor stops (stop position).

Frame Back

To move the embroidery frame only to the direction where the stitches return with the needle bar(s) stopped.

Frame coordinates

Frame position in embroidery space. It is indicated like "X: -153.2, Y: +120.4".

Frame Forward

To move the embroidery frame only to the direction where the stitches advance with the needle bar(s) stopped.

Frame Limit

Limit position that the frame can move (it is indicated by mark-off line on the table).

Frame stepping

To move the embroidery frame only with the main shaft of the machine is stopped during embroidery.

Function Code

Command code that controls general movements of the machine. All design data consists of function codes (Stitch, Jump, Color, etc.).

<H>**Head group**

Function that assumes multiple heads as one head by grouping them. This enables large design embroidery or multi-color embroidery with more colors than the number of needles per head.

<I>**Inching**

Movement to stabilize start of sewing by moving needle bar slowly before the main shaft enters normal operation. It is also executed before thread trimming to stabilize thread trimming.

<J>**Jump**

To make only the frame move in the state that needle bar does not move down during operation. It is possible to make a longer stitch than one stitch of the maximum length.

<M>**Main shaft brake**

To hold the main shaft with the brake of the main shaft motor so that the main shaft does not rotate when it stops.

M-axis

Drive shaft to rotate nipple and bobbin (TLMX series).

<O>**Offset start position (Offset position)**

Frame travel start position that is configured by operating the Automatic Offset. The position to make the frame stand by to facilitate changing of frame and/or fabric by moving the frame to the front automatically in the middle of sewing or at the end of sewing.

1

2

3

4

5

6

7

8

<P>

Parameter

Setting items that decide the working condition of the machine.

Pseudo-fixed position (stop at the lower dead point)

The machine should be stopped with the needle stuck in the cloth at the end of embroidery. Moving the frame in this condition will enable consecutive embroidery.

<R>

Return stitches

Tie stitch to be executed at start of sewing (stitch to prevent mis-stitching at start.).

Running stitch

Decorative stitch of straight line or curved line only.

<S>

Satin Stitch

Repeated zigzag stitches. It is mainly used for hem of applique, logo, mark, flower design, etc.

Seed beads needle

Needle that embroiders with beads by seed beads device. It indicates the first needle or the last needle.

Sequin needle

Needle that embroiders with sequins by sequin device. It indicates the first needle or the last needle.

Sidekick

Name of the network application software manufactured by Pulse Microsystems Ltd. It is possible to input the design data to the machine by wireless LAN as a main function.

Step

The section divided by a color change code in the design. The first section is called Step 1 and the next section is called Step 2.

<T>

Table offset

To move the frame to the rear direction temporarily to facilitate threading. It is mainly effective when the frame is positioned at the table cut section.

Tatami stitch

Stitches to fill in a certain amount of area. They are mainly used for a big logo, background, underlay etc.

TBF

Stitch data for Tajima binary format. Data saving format is T2. It can support more function codes than DST. It is necessary to handle TBF, CT0, and DGF as a set on a personal computer.

TCF

Data that integrates TBF, CT0, and DGF. Integration facilitates handling of designs. Data saving format is T3.

Tie stitches

Tie stitch to be executed before thread trimming (stitch to prevent fray).

<X>

X-axis drive system

Drive system to make the embroidery frame move in the horizontal (X) direction.

X data

The data that makes the embroidery frame move right/left direction (X direction). It is indicated by moving direction (code: +/-) and the value (mm).

<Y>**Y-axis drive system**

Drive system to make the embroidery frame move in the vertical (Y) direction.

Y data

The data that makes the embroidery frame move front/rear direction (Y direction). It is indicated by moving direction (code: +/-) and the value (mm).

<Z>**Z-axis**

Drive shaft to change needle height (TCMX series).

1

2

3

4

5

6

7

8

■ **Manufactured by: TISM Co.,Ltd.**

NO.1800, Ushiyama-cho, Kasugai, Aichi-pref., 486-0901, Japan
Telephone: 81-568-33-1161 Fax: 81-568-33-1191

■ **Distributed by: Tajima Industries Ltd.**

19-22, Shirakabe, 3-chome, Higashi-ku, Nagoya, 461-0011, Japan
Telephone: 81-52-932-3444 Fax: 81-52-932-2457

