



A2Z HEAT PRESS

Operator's Manual



Get Pressin'





Safety Precautions

Before You Start, Read the Safety Precautions

When using your heat press, basic precautions should always be followed, including the following:

1. Read all instructions.
2. Use heat press only for its intended use.
3. To reduce the risk of electric shock, do not immerse the heat press in water or other liquids.
4. Never pull cord to disconnect from outlet, instead grasp plug and pull to disconnect.
5. Do not allow cord to touch hot surfaces.
6. Allow heat press to cool completely before storing.
7. Do not operate heat press with a damaged cord or if the equipment has been dropped or damaged. To reduce the risk of electric shock, do not disassemble or attempt to repair the heat press. Take it to a qualified service person for examination and repair. Incorrect assembly or repair could increase the risk of fire, electric shock, or injury to persons when the equipment is used.
8. This appliance is not intended for use by persons (including children) with reduced physical, sensory or mental capabilities, or lack of experience and knowledge, unless they have been given supervision or instruction concerning use of the appliance by a person responsible for their safety.
9. Close supervision is necessary for any heat press being used by or near children. Do not leave equipment unattended while connected.
10. Burns can occur when touching hot metal parts.
11. To reduce the likelihood of circuit overload, do not operate other high power equipment on the same circuit.
12. If an extension cord is necessary, then a 12-gauge, 20-ampere rated cord should be used. Cords rated for less ampereage may overheat. Care should be taken to arrange the cord so it cannot be pulled or tripped over.
13. If the supply cord is damaged, it must be replaced by the manufacturer, its service agent or similarly qualified persons in order to avoid a hazard.

Table of Contents

2	Safety Precautions
4	Part Identification
5-8	Operating Instructions
5	Initial Setup
5	Maintenance & Service
5	Transportation & Storage
6	Getting Started
8	Changing the Lower Platen
9	Electrical Schematic
10-11	Replacement Parts List
12	Contact

Part Identification

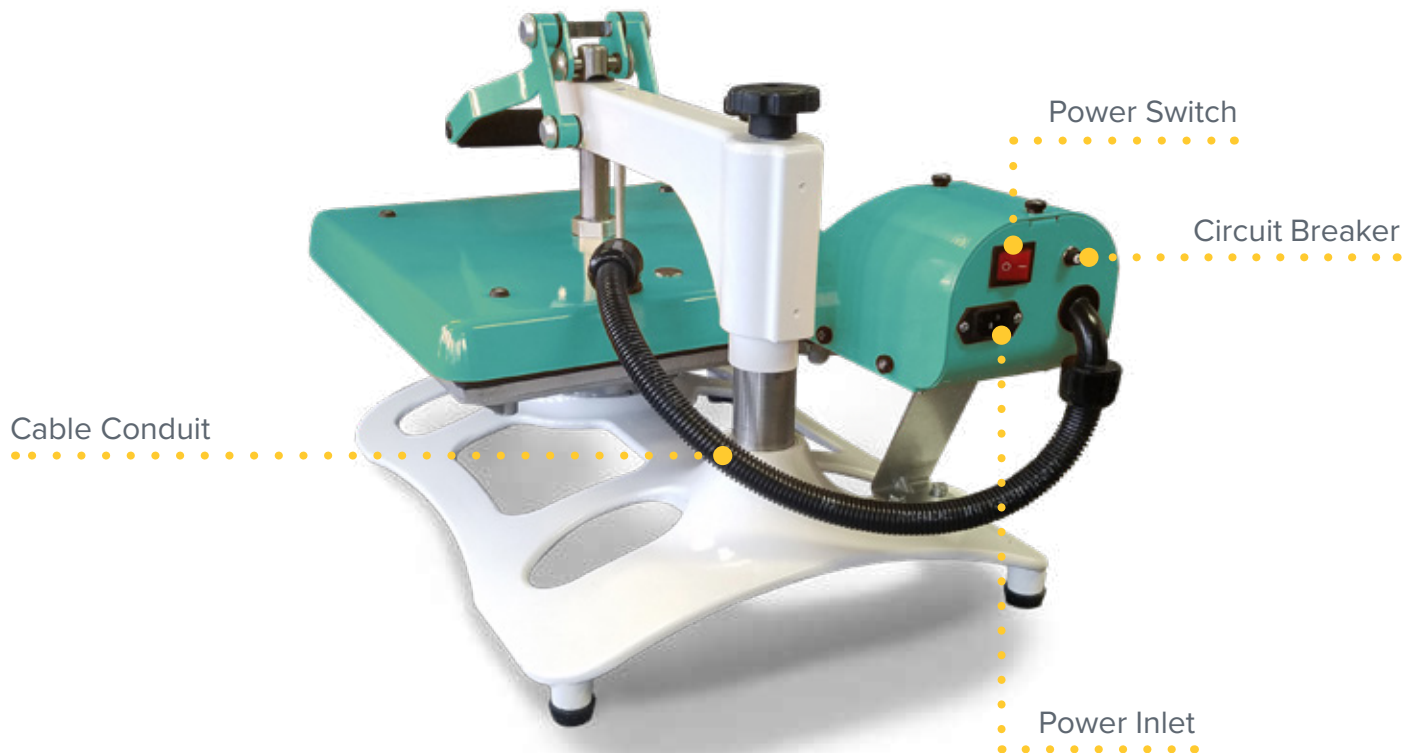
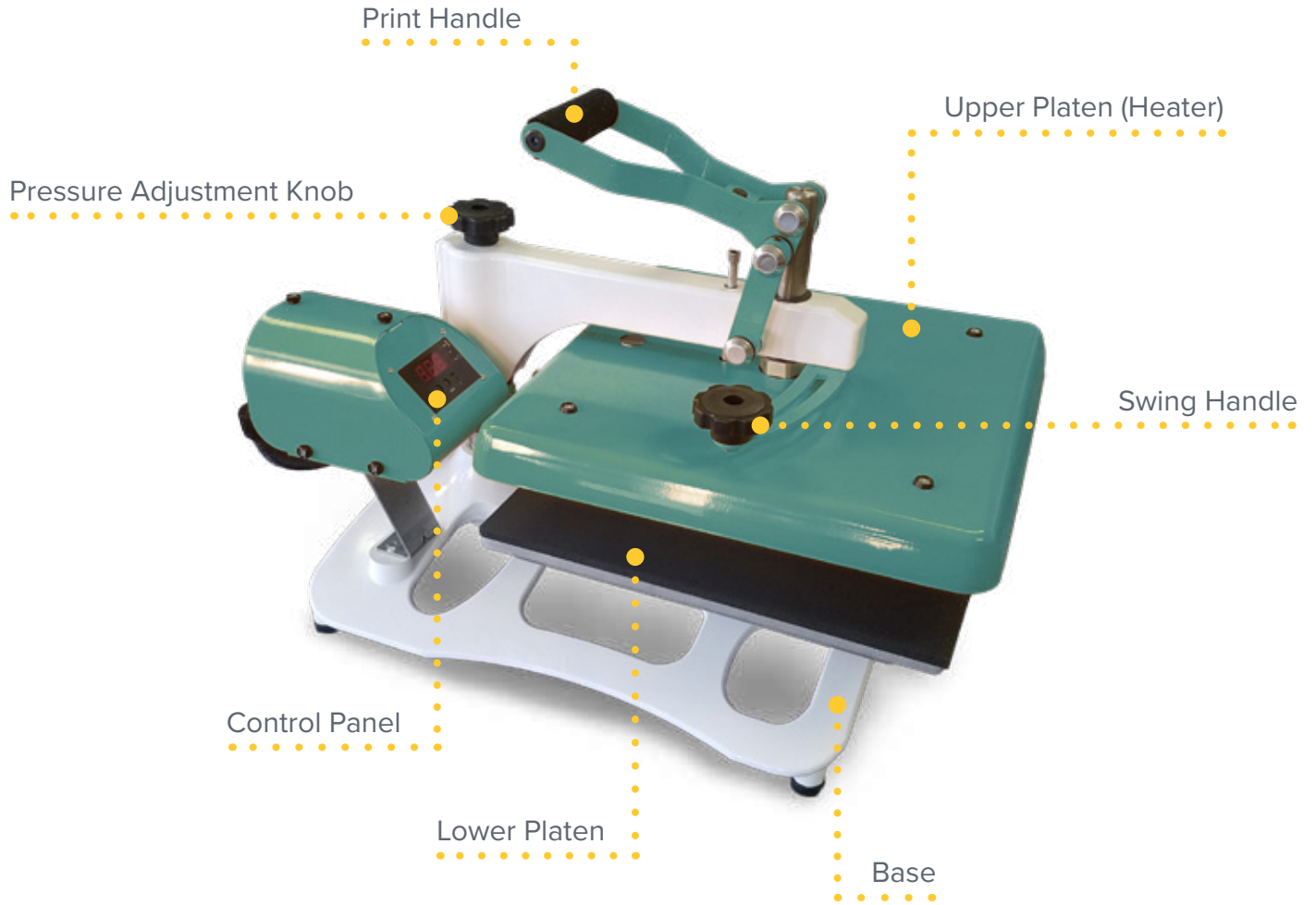

Operating Instructions

Initial Setup

Carefully follow the step-by-step instructions for best results:

- To avoid burns, do not touch the heated upper platen during use.
- Keep hands clear of the upper platen during platen lock down as the pressure may cause injury.
- Press should be placed on a sturdy, level surface at least 30"L x 20"W x 29"H.
- Keep the work area clean, tidy and free of obstructions with enough space to swing the press open.
- Connect the power cord into a properly grounded 120 volt electrical outlet with a minimum 20 amp rating.
- If necessary, a minimum 12-gauge, 20 amp extension cord is required.

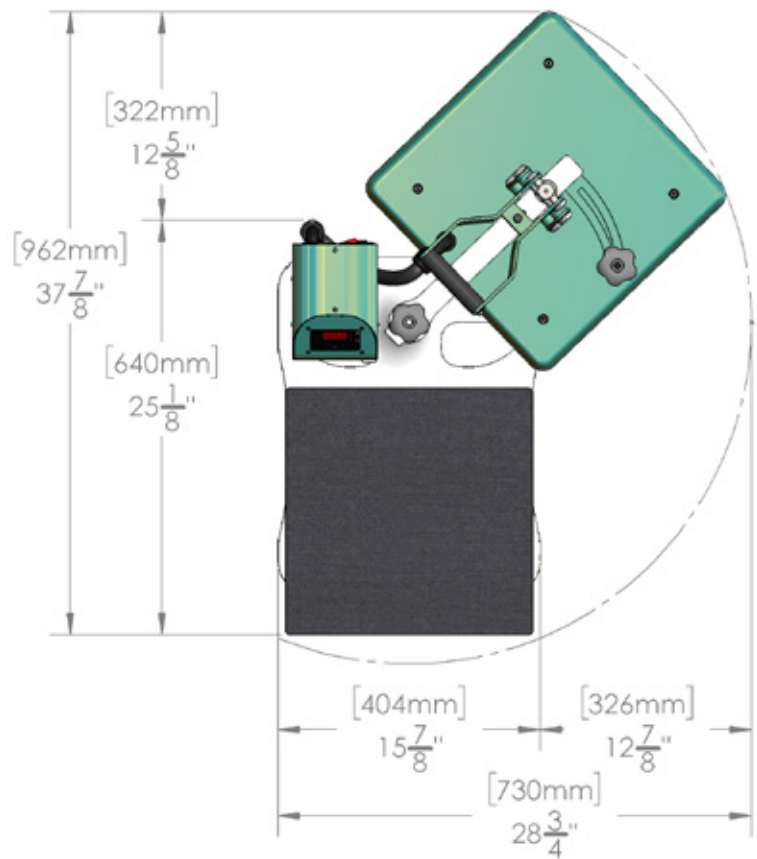

Maintenance & Service

WARNING: Disconnect the appliance from its power source during service or when replacing parts.

Your heat press requires minimal service to achieve a long, trouble-free life:

1. Clean exposed surfaces with a damp cloth to prevent dust buildup, which could lead to overheating.
2. All other maintenance and service should be performed by an authorized service representative.

Transportation & Storage

WARNING: Allow heat press to cool before moving or storing.

Moving the heat press is easiest with the handle in the lowered and locked position.





Operating Instructions

Getting Started: Temperature, Time, and Pressure

Recommended settings vary based on the garment material and type of transfer. It's important to review the application instructions included with your transfers for the recommended settings. Lasting, durable prints can be easily achieved when observing these three essential specifications.

- **TEMPERATURE** must be high enough to melt the transfer adhesive or cure the ink but not so high that it scorches, marks or otherwise damages garments. This setting has the greatest effect on heat transfer success.
- **TIME** controls the amount of heat transferred to the garment. Much like cooking in an oven, stopping early or taking too long will have unwanted effects. Thick transfer products may require a longer press time.
- **PRESSURE** drives your transfer deep into the garment fabric for a stronger and more durable bond. It flattens garments to prevent wrinkles, creases and seams from distorting the printed image. However, too much pressure can wear down mechanical parts.



With the print handle in the raised position, rotate the knob to adjust PRESSURE.

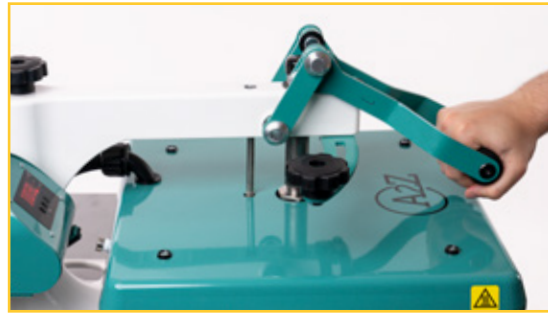

Lower the print handle into the locked position to test your PRESSURE and adjust as needed until the desired level is achieved.



Flip the power switch on the back of the controller to turn on the heat press.



While no LEDs are illuminated, the controller displays the current heater temperature. Press the MODE button to set the TEMPERATURE and TIME.



Press MODE once to change the TEMPERATURE. While SET and TEMP are illuminated, press (+) and (-) buttons to adjust the TEMPERATURE.



Press MODE twice to set the TIME. While SET and TIME are illuminated, press (+) and (-) buttons to adjust the TIME.

NOTE: The press will not heat while SET is illuminated.

NOTE: The press will not heat while SET is illuminated.

Operating Instructions



Using the swing handle, move the upper platen to access the lower platen. While heating, the print handle should remain raised to extend the life of the silicone pad.



Position the garment on the lower platen, centering the transfer area on the platen.



For best results, “thread” the garment around the lower platen so a single layer of fabric is on top of the silicone pad.



Some transfer products recommend a “pre-press” to heat and flatten the garment before printing. Using the swing handle, position the upper platen over the garment.



Lower the print handle fully until the upper platen locks into the press position. After the recommended pre-press time has elapsed, lift the print handle.



Swing away the upper platen and align the transfer on the garment.



Lower the print handle fully until the upper platen locks into the press position. After the required time has elapsed, lift the print handle.



Using the swing handle, move the upper platen to access the garment. Depending on the transfer, peel the carrier hot or cold.

Changing the Lower Platen

Your heat press is equipped with an interchangeable lower platen.

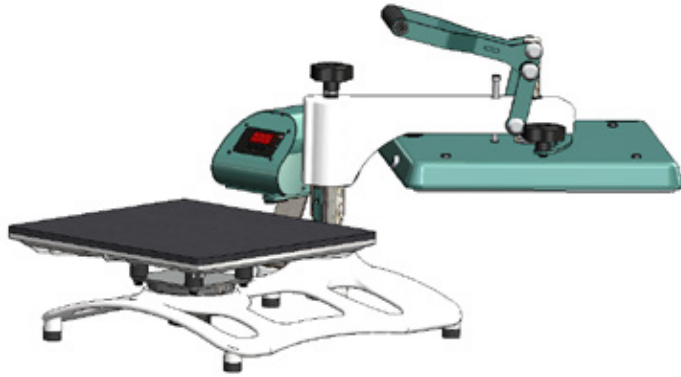

Swing away the upper platen using the swing handle to access the lower platen.

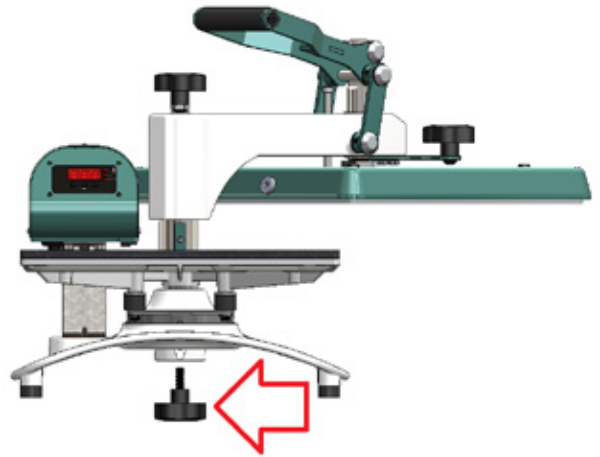

Loosen and completely remove the platen knob located underneath the base.



Lift the 15" x 15" lower platen off the heat press and set aside.

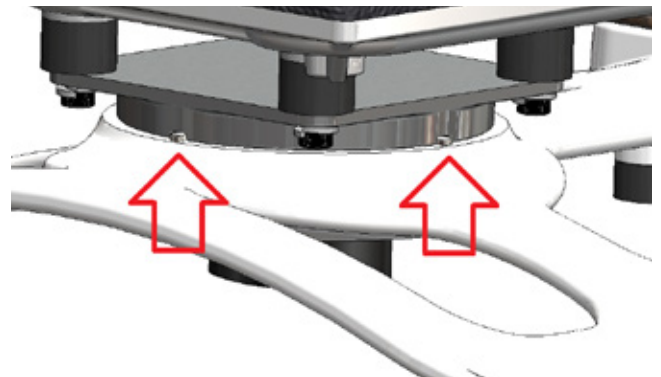

Place the new platen onto the base, taking care to align the platen keys for a secure fit.

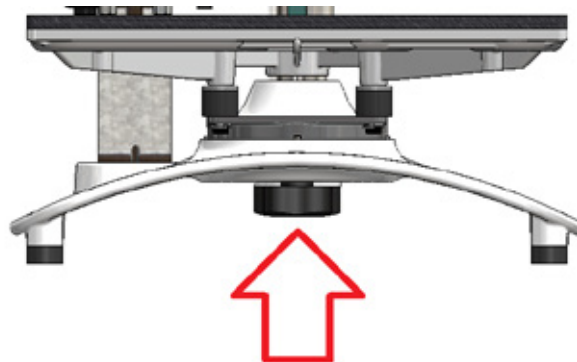

Return the platen knob and tighten.

Electrical Schematic

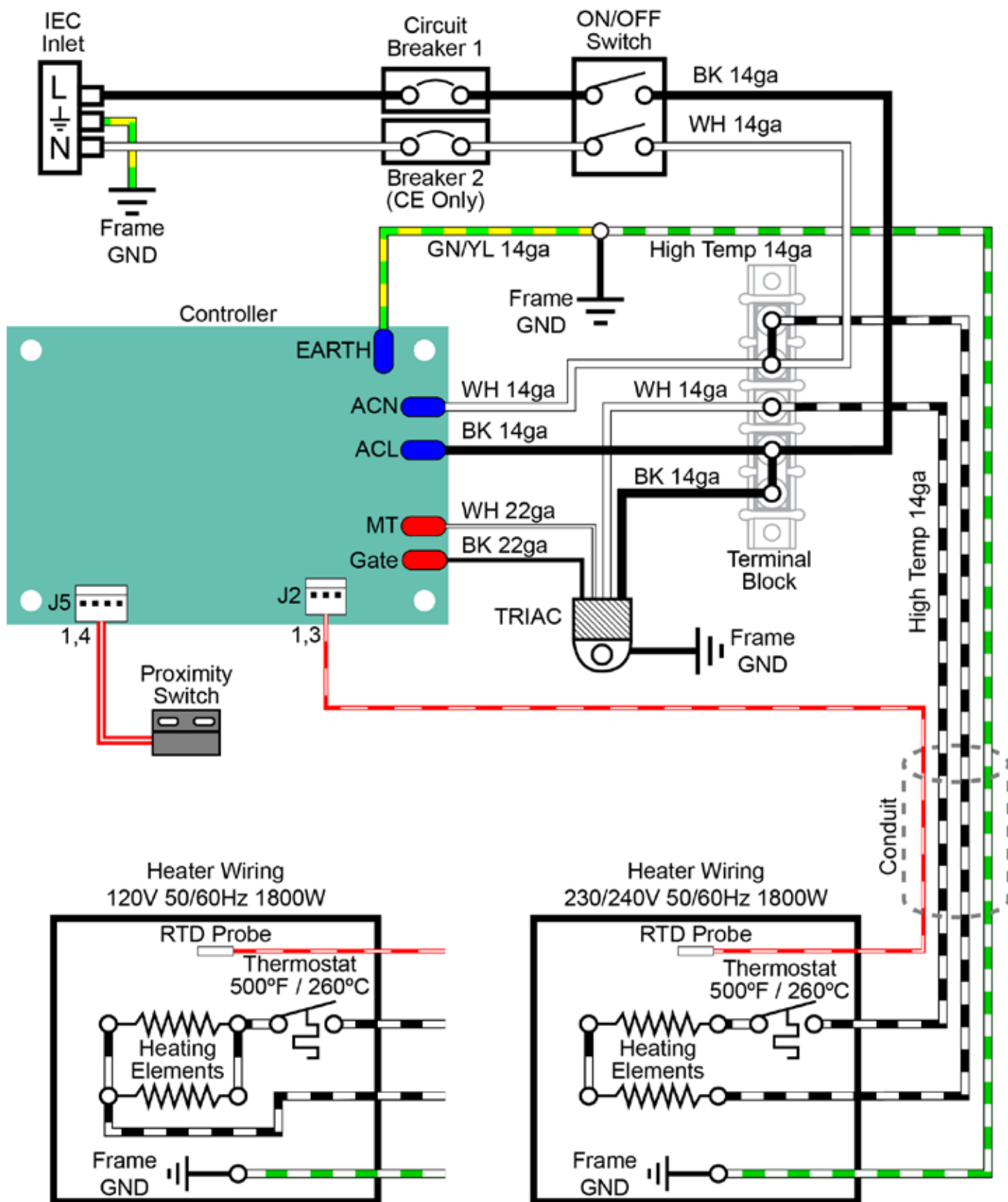

All copyright, trademarks and all other intellectual property rights in this document and its content (including without limitation the design, text, graphics and all equipment and patents described within the document) are owned by or licensed to Hotronix, LLC or otherwise used by Hotronix, LLC as permitted by law. 4/20/2020



Replacement Parts List

#	DESCRIPTION	PART #	QTY
1	A2Z Lower Platen, 15" X 15"	3-1384	1
2	Skinny Adapter Plate	3-1336-1	1
3	Silicone Pad 15" x 15" Black	1-2622	1
4	A2Z Control Cradle	1-2595	1
5	A2Z Control Cover	1-2594	1
6	Controller, Craft	1-2604	1
7	Controller Overlay, A2Z	1-2623	1
8	Power Inlet	1-1759	1
9	Power Switch	1-2076	1
10	TRIAC, STX/MAXX	2-1675	1
11	Terminal Block, 5 Contact	1-1290	1
12	Circuit Breaker 20A	1-1331-3	1
13	Screw, Machine #6-32 x 1/2"	3-1011-19	8
14	Screw, Pan Phillips #4-40 x 1"	3-1011-130	4
15	Screw, Machine #6-32" x 1/4"	3-1011-25	4
16	Conduit Fitting, 1/2" Elbow HPASC	1-2618	2
17	Power Cord, 120V Locking	2-1671	1
17	Power Cord, 220V	1-2186	1
17	Power Cord, 230V European Locking	2-1672	1
18	A2Z Arm Casting	3-1382	1
19	A2Z Handle		2
20	JCN Nut, 1/4"-20	2-1006-2	2
21	Rubber Foot, Small Push-In	1-1056	2
22	Nylon Bushing, Flanged 1/2" x 1/4"	1-2627	4
23	PVC Spacer, 1/2" x 4.5"	1-1049-16	1
24	Foam Grip, Black	1-1540	1
25	Threaded Rod 1/4"-20 x 4.50	1-1042-2	1
26	Nylon Bushing, Flanged 1/2" x 3/8"	1-2628	3
27	Nylon Bushing, Flanged 1" x 1"	1-2282	3
28	Set Screw, 1/4"-20 x 1/4"	3-1011-258	2
29	Pin, 1/2" x 2-3/4"	2-1055-30	1
30	A2Z Heater Spindle	3-1387	1
31	Pin, 1/2" x 4"	2-1055-31	1
32	Hub Cap 1/2"	1-1107-1	6
33	Nylon Washer	1-1048-3	4
34	Zinc Plated Clevis Pin, 1/2"D x 1"L Usable	1-2629	2
35	A2Z Swing Arm		1

#	DESCRIPTION	PART #	QTY
36	3/8-16" x 3/4" HHCS ZINC	3-1011-41	1
37	Knob with Cap, 3/8"-16 Thread	1-2621	3
38	Washer, Split Lock 1/4"	2-1006-44	11
39	Rubber Foot, 1"D with 1/4"-20 Stud	1-2620	4
40	Screw, 1/4"-20 x 3" Socket Head Cap, Zinc	3-1011-280	1
41	A2Z Pressure Link		2
42	Heater, 15" x 15" A2Z	5-1000-1	1
43	Nylon Bushing, Flanged 7/16" x 3/8"	1-2630	1
44	A2Z Heater Cover, 15" x 15"	3-1351	1
45	Screw, 3/8"-16 x 2", Socket Head Cap	3-1011-281	1
46	Vibration Damper	1-1056	4
47	Thermostat	1-2076	2
48	Insulation 15" x 15" x 1/2"	1-2257	1
49	Washer, Plastic Finishing	1-1063	4
50	Screw, #10-24" x 1/2", Phillips Flat Head Thread Rolling	3-1011-217	4
51	Screw, 5/16"-18 x 5", Socket Head Cap Zinc Plated	3-1011-282	1
52	Nut, Hex 3/8"-16 Nylok	2-1006-10	2
53	Washer, 1/4" Faucet PTFE	2-1006-111	2
54	Magnet, Neodymium 0.625" x 0.25" with #6 CSK	1-2486	1
55	Screw, #6 x 3/4" Self Tapping	3-1011-154	1
56	A2Z Base Casting	3-1381	1
57	Proximity Switch	1-1211	1
58	Conduit, 1/2" x 20"	2-1048-3	1
59	A2Z Spine		1
60	A2Z Control Box Support	1-2596	1
61	Screw, 1/4"-20 x 1/2" Hex Head Cap	3-1011-11	11
62	A2Z Control Adapter Plate		1
63	Screw, 1/4"-20 x 5/8" Flat Socket Head	3-1011-283	2
64	1/4"-20 Nylok Nut	2-1006-7	3
65	Nord-Lock Washer 1"	2-1006-94	1
66	Nut, 1"-12 Thin Jam	2-1006-110	1
67	A2Z Swing Stop		1
68	Spring, 1.4" x 3"	1-2631	1
69	Screw, 3/8"-16 x 5", Socket Head Cap	3-1011-284	1

Exploded View

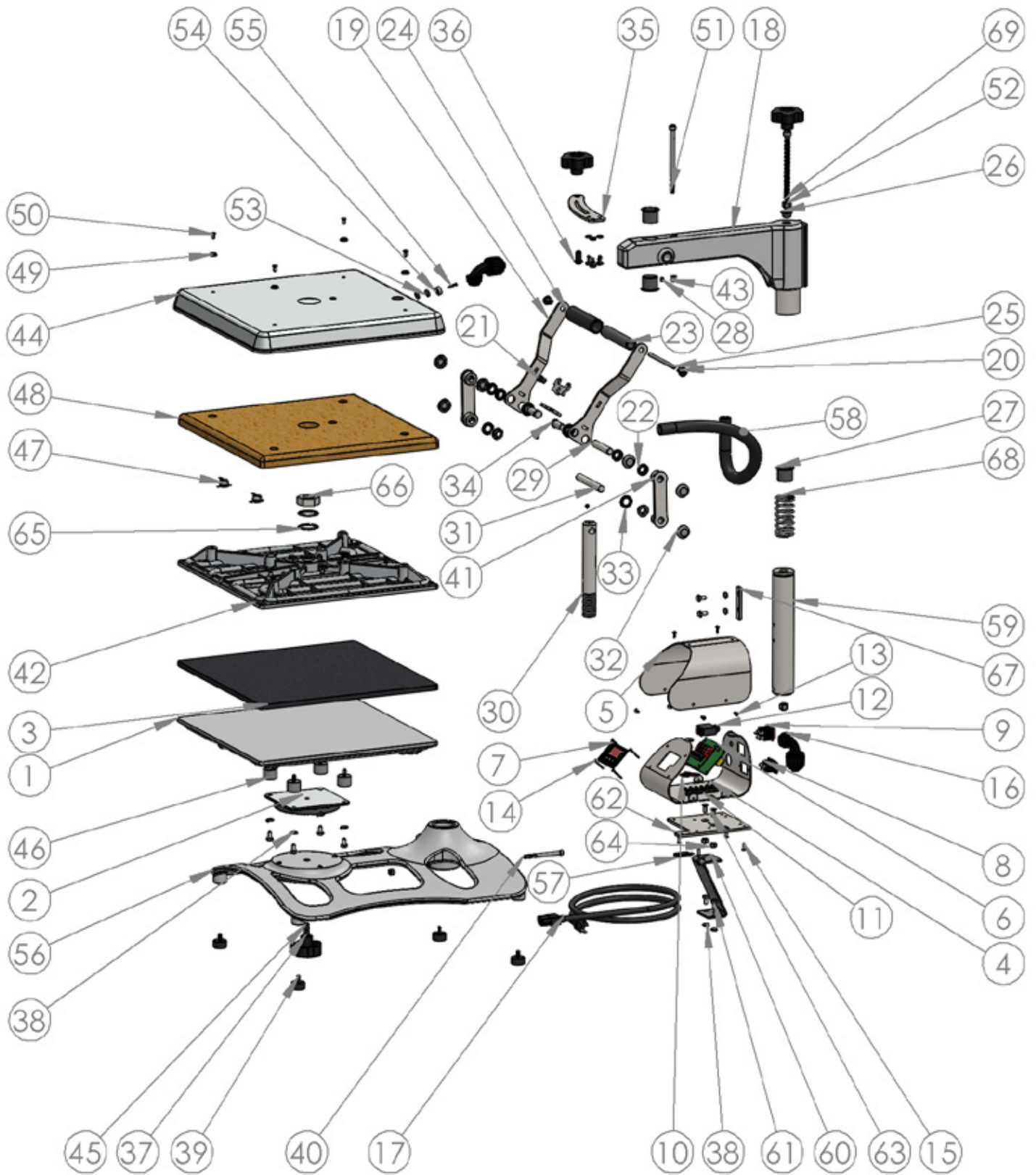



Contact Us

Support@A2ZHeatPress.com

A2ZHeatPress.com