



Autoflash

Assembly, Operating, and Maintenance Instructions For Vastex Autoflash Attachment with Touch Screen Controls



Contents	Page#
• Introduction / Safety	2-3
• Spec Tag Info	4
• Stand Assembly	5-6
• Component Identification	7
• Assembly	7-8
• Controls / Operation	9
• Maintenance	10
• Troubleshooting	10
• Warranty / Terms & Conditions	11

Vastex International, Inc.
 7 Emery St
 Bethlehem, Pa. 18015-1982 USA
 Phone# 610 625-2702 Fax# 610 625-2775
 Web Site www.vastex.com

Authorized Representative in Europe:
 Certification Experts BV
 Nieuwstad 100 1381 CE Weesp,
 The Netherlands
 Tel : + 31 (0) 294 – 48 33 55
 Fax : + 31 (0) 294 – 41 46 87

Electrical Drawing #: _____ Rev: _____

Serial Number: VTX _____ Date: / /

(Please log your machine's serial number and date of purchase for future reference.)

Vastex E-mail assistance

Purchasing & Product Info:
sales@vastex.com

Electrical Support:
stech@vastex.com

Tech Support, Mechanical Setup, and Operation:
techsupport@vastex.com

Screen Printing Issues & Support:
printech@vastex.com

— Introduction

Congratulations, you have chosen a VASTEX Autoflash Attachment. VASTEX has been designing and building screen printing equipment since 1960 and has the knowledge and expertise to supply a quality machine and help you keep it running for years to come. VASTEX has innovated many of the features found in screen printing equipment today from control methods, modular features, air movements, belt tracking and even the dual rotary manual press. All components are tested to be sure they work correctly when the equipment leaves our factory.

— Safety

The Instruction Manual and Safety Instructions must be read and understood by anyone operating the Vastex Conveyor Curing System.

- The operator should read and understand the instruction manual before operating this equipment. Store instruction manual and safety instructions near equipment for easy access to operators.
- VASTEX Autoflash attachment is for use on Vastex Flash units in accordance to the language in this manual. Do not use for any other purpose unless authorized by Vastex International, Inc. Use of this equipment for any other purpose can be dangerous and may cause damage to this equipment, voiding the warranty.
- It is recommended that the area around this equipment be designated as a work area and only authorized employees be allowed in the area.
- Children and pets must be kept clear of the work area.
- Do not place any objects on top of the Autoflash or Flash Head. Surfaces are hot!
- Never leave equipment unattended.
- Do not operate Autoflash with any cover or guard removed.
- Operator must be familiar with controls of the Autoflash and Flash Head.
- Before starting production, the operator must check that all covers and guards are in place, no material has been placed on or under the Autoflash or Flash Head, and the work area is clear of obstructions.
- Always turn off power at the main disconnect at the end of production.
- In case an abnormal symptom occurs, for example excessive vibration, noise, and strong smell or smoke development, turn off the VASTEX Autoflash and contact a qualified technician.
- Do not remove any cover or guard until power at the main disconnect is switched off and locked out. No unauthorized persons are to be allowed inside the control boxes.
- Turn off and lock out power at the main disconnect before any cleaning or maintenance.
- Only qualified technicians should be allowed to make repairs on the VASTEX Autoflash.
- **Noise and vibration:** This equipment does not produce noise exceeding 70 dB(A) at workstations.
- **Operating Temperature:** Vastex Equipment should not be operated in temperatures below 40°F(5°C) or above 105°F (41°C)

— Safety (cont'd) —

- **Stability during use, transportation, assembly, dismantling when out of service, testing, and foreseeable breakdowns:** This equipment is designed and expected to be stable during all foreseeable conditions, so long as the procedures and instructions given in this manual are followed.
- **Safe handling, transport, and storage:** Before storing the unit, detach Flash Head from AutoFlash and store separately. No special handling considerations are necessary, except to be aware of the weight of the equipment and take standard precautions for moving such weights:

Autoflash (AF-120/AF-240) 51 Lb(25 kg) 31" x 22" x 14" (79 x 56 x 36 cm)

— Residual Risks —

Please read and understand all parts of this manual to avoid any Residual Risks.

- Your Vastex Autoflash moves a high temperature heater. There is an inherent danger when dealing with a heat source of this degree. These heaters are often run at temperatures near 1,000° F(538° C). Any body part or item that comes in direct contact with the heater on the Flash Head will be damaged. The heaters are guarded against direct contact from all sides except the bottom.

— Workspace —

- The workspace that your Autoflash occupies must be kept clean and clear of debris.
- Do not store items, especially food or drink, on the top of your Vastex equipment.
- The room that you are operating your Autoflash in should be adequately ventilated. Please refer to the MSDS sheet of the ink you are flashing/curing.

— Important

Please read and understand your Flash Head manual before attempting to use or assemble this Autoflash Attachment. Flash head manuals can be found at www.vastex.com or call us to have one emailed/mailed to you directly. This manual only covers the assembly, operation, and maintenance of your Autoflash Attachment.

Placing your equipment into service and using your machine:

To place your machine into service, follow the assembly instructions on Pages 5-8.

To use your machine, reference the control section on Page 9.

— Spec Tag

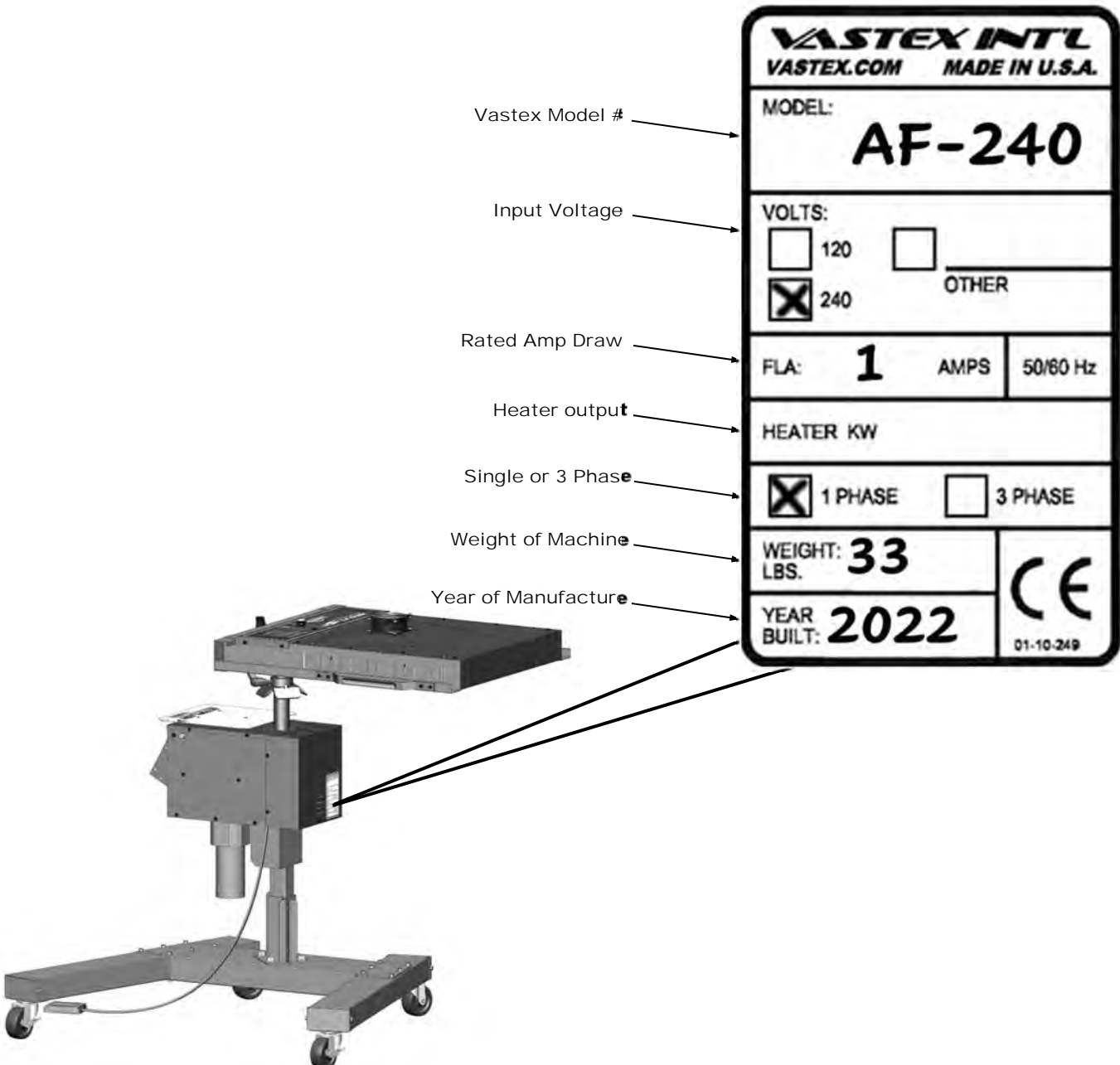

Vastex Model # →

Input Voltage →

Rated Amp Draw →

Heater output →

Single or 3 Phase →

Weight of Machine →

Year of Manufacture →

VASTEX INT'L VASTEX.COM MADE IN U.S.A.		
MODEL: AF-240		
VOLTS: <input type="checkbox"/> 120 <input type="checkbox"/> OTHER <input checked="" type="checkbox"/> 240		
FLA: 1	AMPS	50/60 Hz
HEATER KW		
<input checked="" type="checkbox"/> 1 PHASE <input type="checkbox"/> 3 PHASE		
WEIGHT: 33 LBS.		CE 01-10-249
YEAR BUILT: 2022		

— Assembly (SHHD-STAND)

1) Remove all parts from the box they were shipped in.

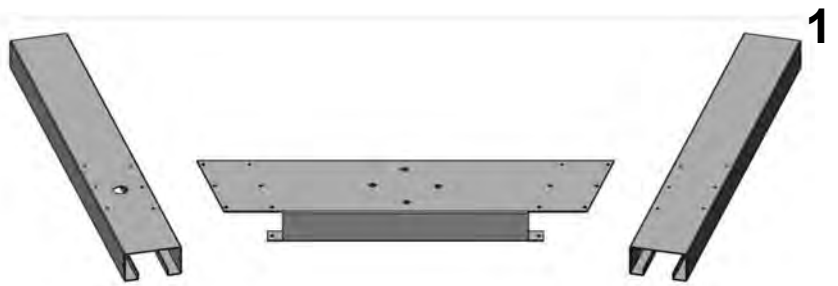

2) Place Legs and Middle on floor as shown. Note hole in left leg for orientation.

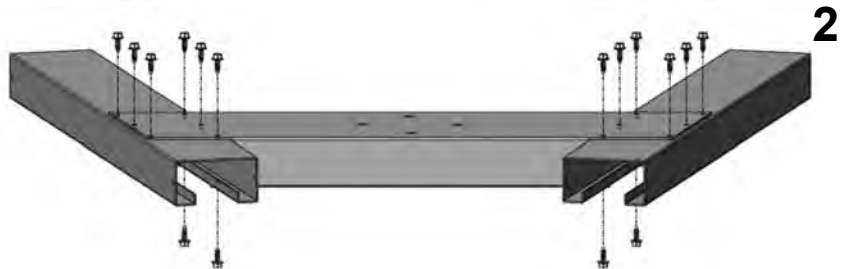

3) Install and Tighten
-(16) #14 Sheet Metal Screws
Use 3/8 Socket or Wrench

4) Install and Tighten (4x)

-Attach Wheel and Stud to each bracket with 1/2" nut.
Use 3/4 Socket or Wrench

-Attach Wheel bracket to Stand Legs using (2) #14 Sheet Metal Screws
Use 3/8 Socket or Wrench

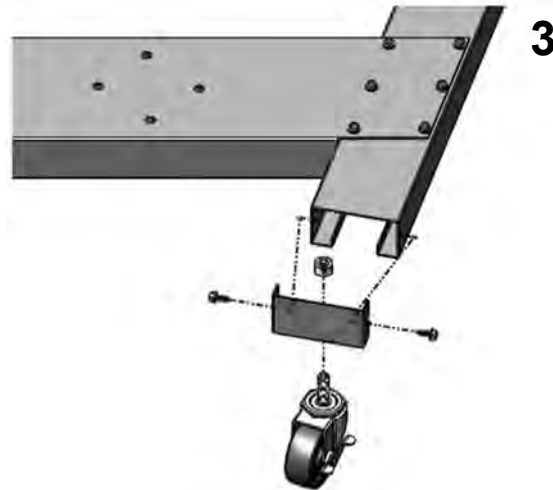

5) Install and Leave Loose
-(4) 3/8 Bolts, lock washers, and nuts

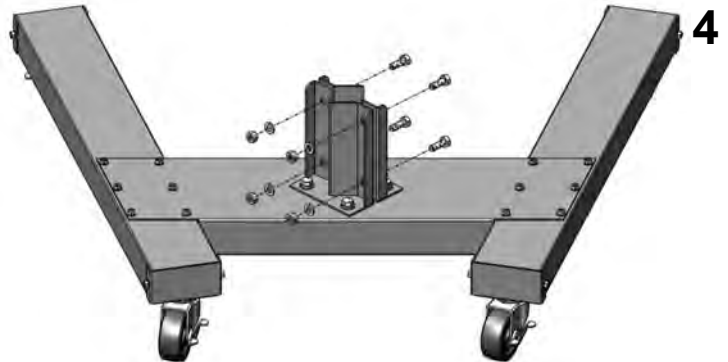

6) Install and Leave Loose
-(4) 3/8 Bolts, washers, and lock washers

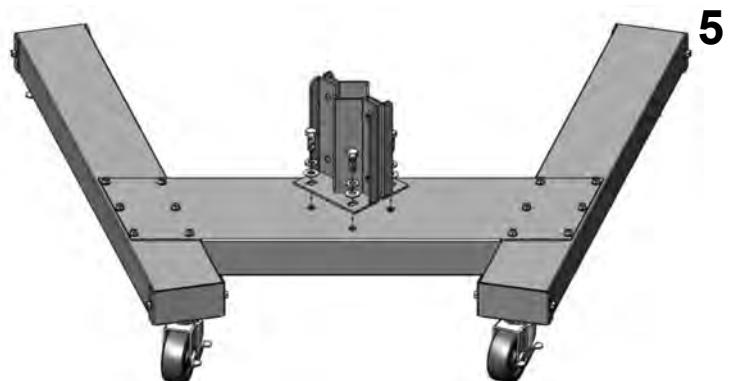

— Assembly (SH-STAND)

- 1) Install and Leave Loose**
- (2) Legs
- (2) 1/4" Bolts and Nuts
Note Orientation of legs

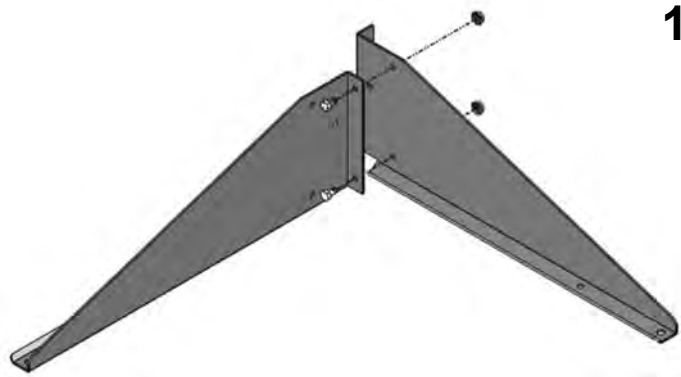

- 2) Install and Leave Loose**
- (1) Leg
- (2) 1/4" Bolts and Nuts

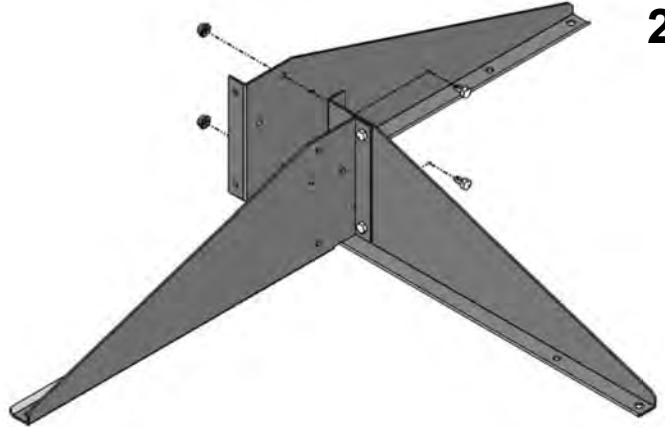

- 3) Install and Leave Loose**
- (1) Leg
- (4) 1/4" Bolts and Nuts

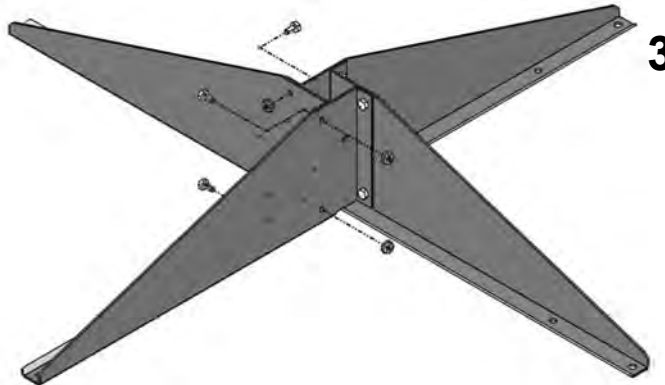

- 4) Install and Tighten**
- (4) Wheels with studs
- (4) 3/8" Nuts
Use 9/16 Socket or Wrench

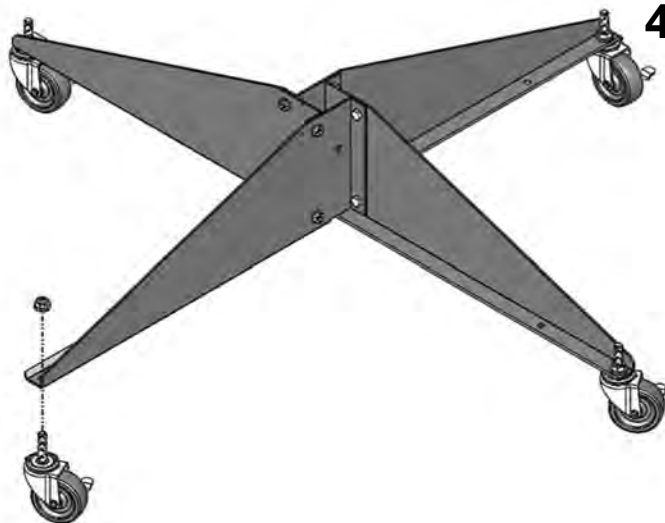

— Component ID

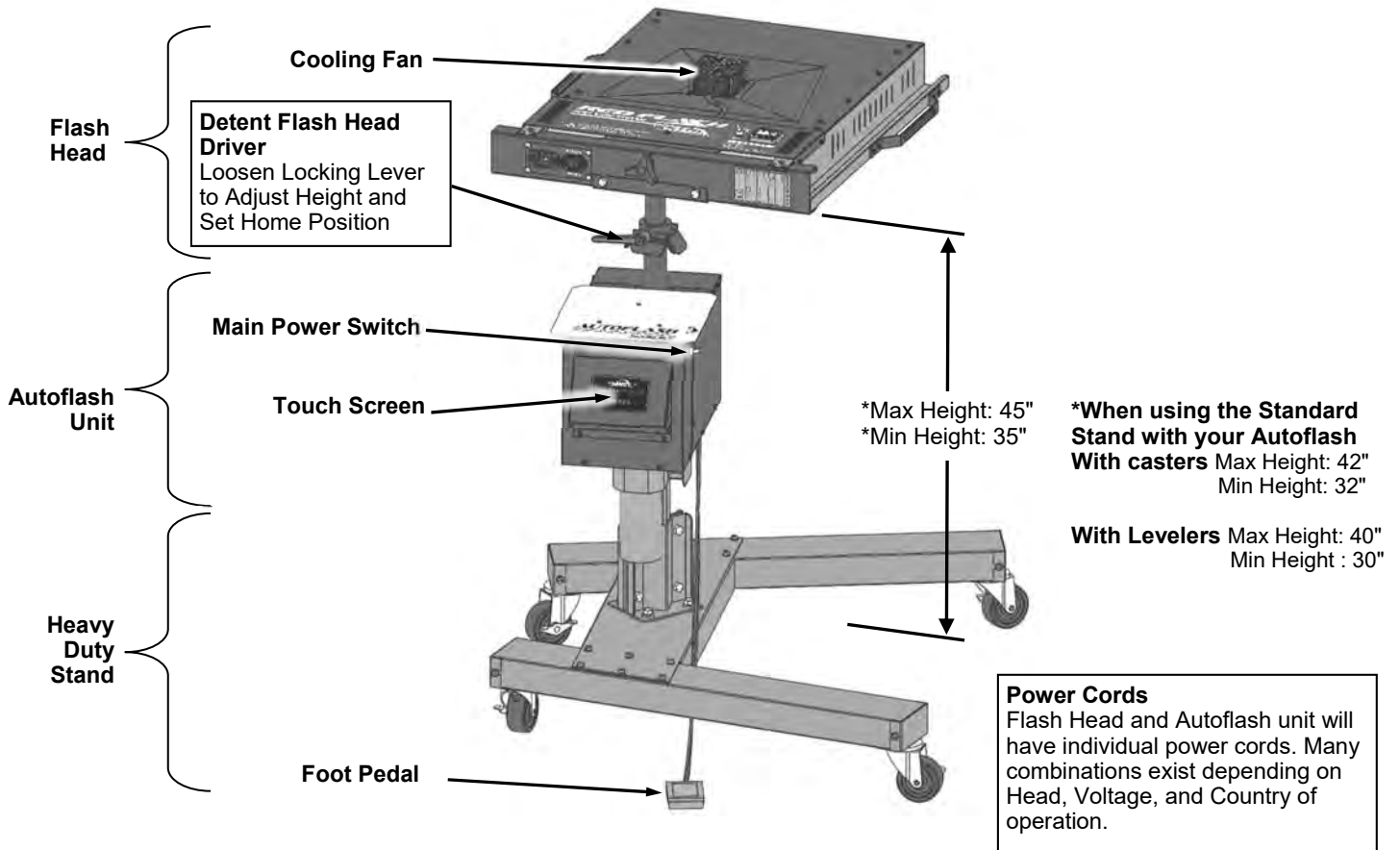

— Select home position

Installing AutoFlash Unit on to SHHD Stand

-Orientation is based on user operation

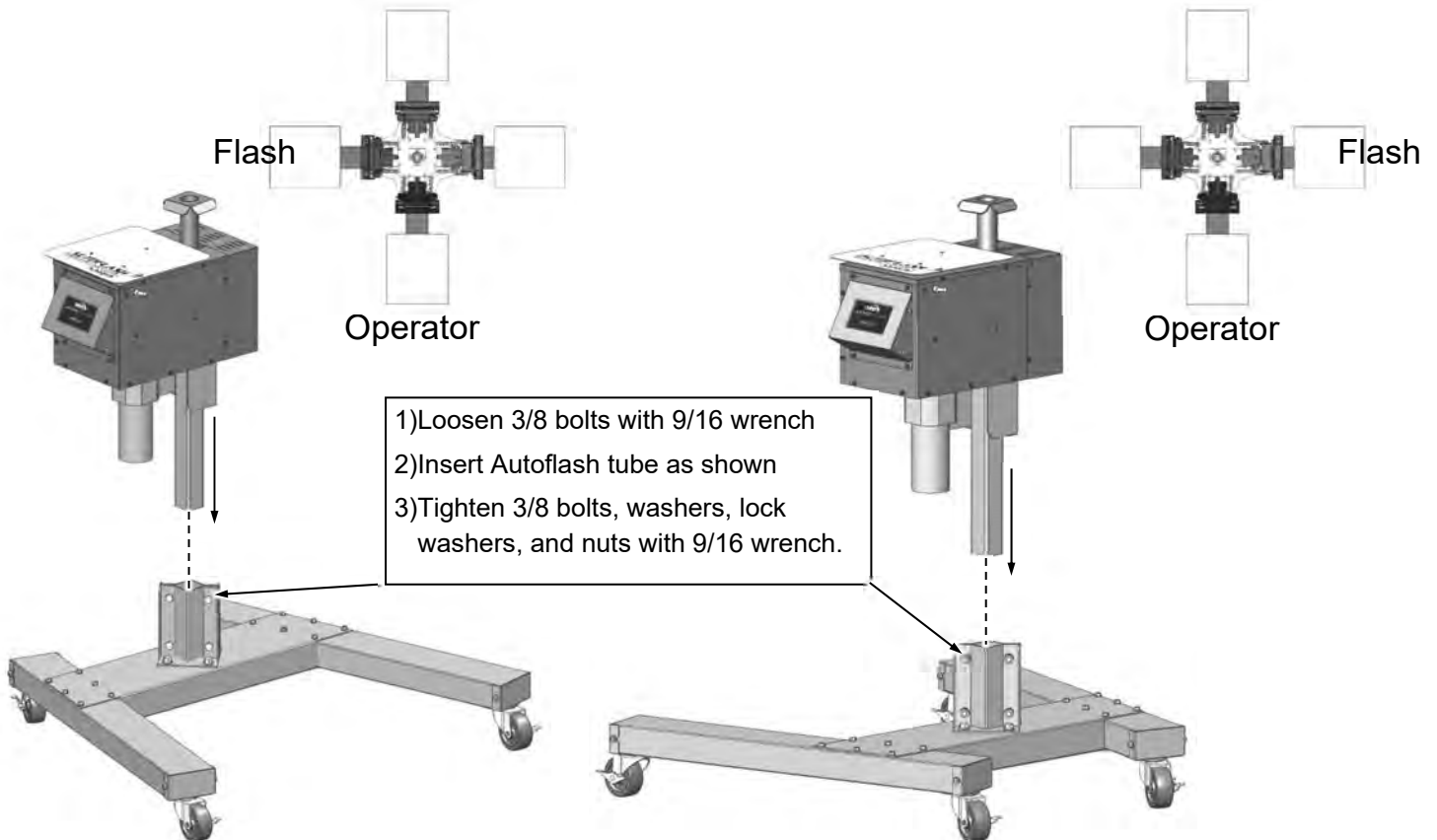

— Assembly Cont'd —

Installing AutoFlash Unit on to Standard Stand

- 1) Loosen 1/4" bolts with 7/16 wrench
- 2) Insert Autoflash tube as shown
- 3) Tighten 1/4" bolts and serrated nuts with 7/16 wrench.
- 4) Insert Tube and Saddle Assembly along with detent clamp as shown below.
- 5) Flash head attaches to Saddle Assembly using (2) 3/8-16 bolts and washers. Tighten well with 9/16 wrench.
- 6) Install pitch knob and tighten until flash head is level to your pallet.

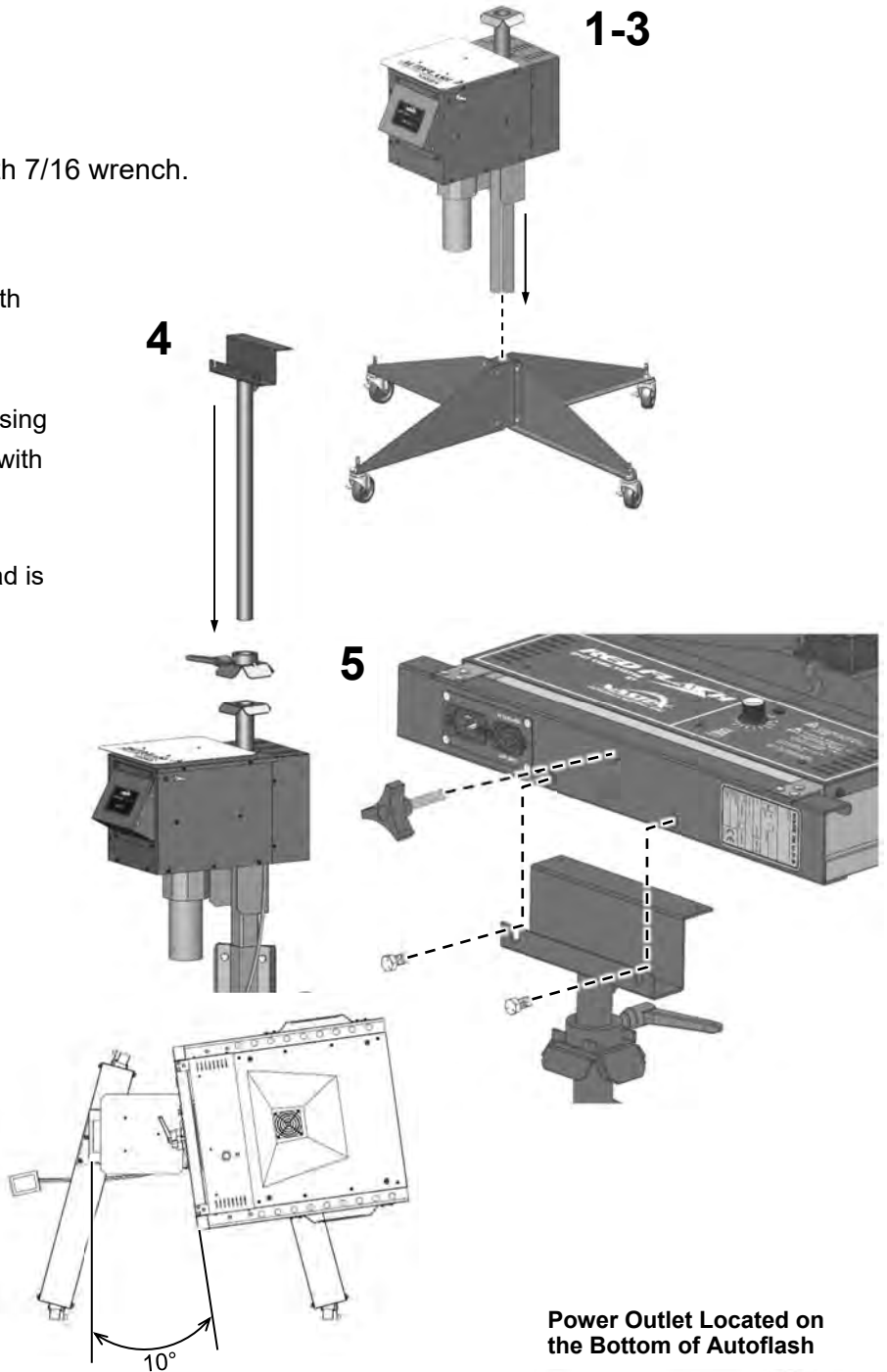

Do Not position the flash head over the control box when in the home position. Excessive heat can damage the electrical components.

- 7) Plug in your Autoflash and Flash head. Refer to wiring diagram and Flash Head manual.

NOTE: If sold as a combo with an Autoflash 240 volt, install the Autoflash power cord to the back of the Flash Head as well.

Power Outlet on Flash Head

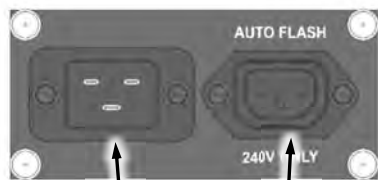

Flash Head Main Power

Autoflash 240V Main Power

Power Outlet Located on the Bottom of Autoflash

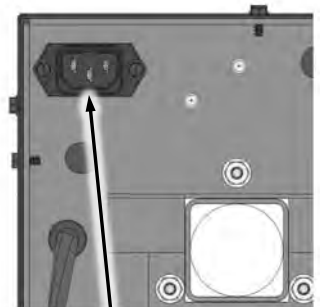

Main Power to Wall Outlet or Flash Head

— Operation

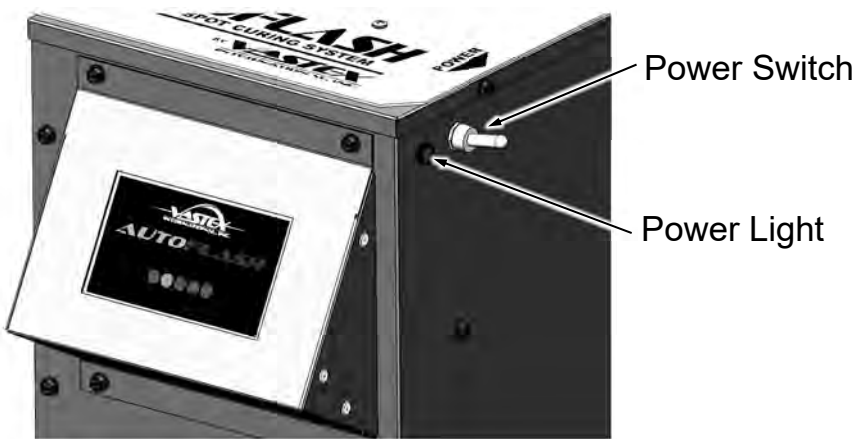

Boot Screen



- Enter Home Screen Setup with Gear
- Set Dwell time with Arrows
- Press Go to Operate

- Select appropriate home Position
-See Pg 7 for desired orientation

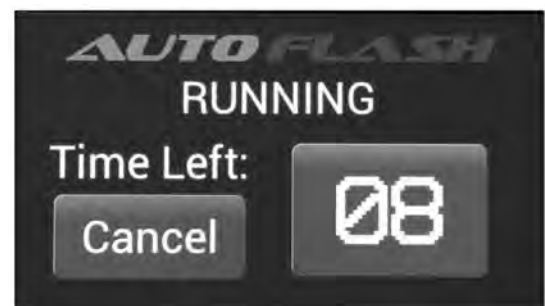
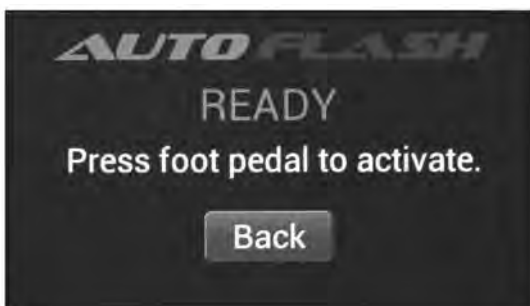

- After pressing go, AutoFlash is ready to run.
- Press Foot Pedal to activate
- Press Back to change Dwell Time

- Displays remaining Dwell Time.
- Press Cancel to return to home position mid cycle.

Maintenance and Troubleshooting

Safe maintenance and troubleshooting:

- Before beginning any maintenance or troubleshooting on your equipment, unplug your machine from its electrical outlet.
- The heat control and/or power switch should be switched off before plugging and/or unplugging the power cord.
- Allow time for the equipment to cool before attempting any service on the heater
- Do not remove any panels with the equipment powered on; any such service must be performed by qualified personnel only.

In the event of a malfunction or breakdown:

Shut off power to the equipment and unplug from electrical outlet. Then, following the troubleshooting charts below. If this does not resolve your issue, please contact Vastex for support.

Troubleshooting Chart—Additional Considerations for AutoFlash Units:

Symptom	Possible Cause	Solution
Unit stops in wrong location	Home and extended positions incorrectly set	Follow instructions on page 9 to set
User wishes to reverse rotation direction of AutoFlash	N/A	Follow instructions on page 9 to reverse direction
Screen does not display anything	Physical Damage or Power issue	Please Call Vastex International

Maintenance:

WEEKLY

- Clean touchscreen with a light screen/lens cleaner. Do not saturate screen when cleaning. Power off machine before cleaning.
- Clean foot pedal of any loose debris or dirt. Power off machine before cleaning.

Vastex Warranty

Doc#01-00-005D Revised 2/20/2018

(1.) Vastex, hereinafter referred to as "seller" warrants only to its original "purchaser", who holds a copy of the original invoice and is the original end user of the equipment in question, its new equipment against manufacturer defects in materials or workmanship on a pro-rated basis. Warranty period begins from date of shipment to the buyer and will only apply to customers paid in full. Warranty periods are as follows: one (1) year for E-1000, three (3) years for all other complete machines (including F-Flash), fifteen (15) years for infrared heaters (excluding F-Flash) installed by Vastex in a new dryer, three (3) years for replacement infrared heaters, and one (1) year for replacement parts. Rubber blankets, light bulbs and glass on exposure units are particularly subject to wear while in use. Wear is not covered by this warranty but as stated above only manufacturers defects are covered. All sales made through Vastex dealers must be certified by that dealer before a warranty replacement is issued. All equipment is thoroughly tested and inspected before packaging. This warranty does not cover minor cosmetic damages that occur during shipment that do not affect the functionality of the equipment.

(2.) This warranty is expressly contingent upon the buyer delivering to seller, at the address below, with all transportation charges prepaid, the part or parts claimed to be defective within the above mentioned warranty periods stated in paragraph one. The defective part or parts will be repaired or replaced at the discretion of Vastex International, Inc. If the equipment in question is less than one (1) year old, it will be shipped to the customer at no charge, with an RGA issued by Vastex for the defective part. The defective part must be shipped back to Vastex freight prepaid within 30 days or the account will be billed. If the equipment is more than a year old, the part will be shipped after we receive the defective part. If it's necessary to expedite the movement of parts and to minimize down time to the buyer, the replacement part shall be supplied on a C.O.D. basis. If testing and analysis of said part by the seller or its supplier discloses that said part is defective, the cost of said part will be refunded to the buyer on a prorated basis.

(3.) Except as otherwise provided herein, the equipment is being sold "as-is". Final determination of the suitability of the equipment for the use contemplated by the buyer, is the sole responsibility of buyer, and seller shall have no responsibility in connection with the suitability.

(4.) All warranties implied by law, including the implied warranties of merchantability and fitness are hereby limited to manufacturer defects in materials or workmanship during the warranty period stated in paragraph one. The express warranty and remedies contained herein and such implied limited warranties are made solely to the sole warranties and remedies and are in lieu of all other warranties, guarantees, agreements, and other liabilities, whether express or implied, and all other remedies for breach of warranty or any other liability of seller, in no event shall seller be liable for consequential damages.

No person, agent, distributor, or service representative is authorized to change, modify or extend the terms hereof in any manner whatsoever.

These terms and conditions are an essential part of the transaction between the parties and constitute the entire agreement between them with respect to the same.

Some states do not allow limitation on how long an implied warranty lasts of the exclusion or limitation of incidental, or consequential damages, so the above limitation may not apply to you.

This warranty gives you specific legal rights, and you may also have other rights which vary from state to state.

Infrared heaters are the only replacement parts covered for a period of (3) years from date of shipment and contingent to receipt of payment in full.

Electrical components cannot be returned once installed unless proven defective.

Please refer to doc. 01-00-015 for specific terms and conditions of sale and the limited warranty.

Please refer to doc. 01-00-017 for V-2000HD printer warranty.

Updates: V1000 to 3 year warranty 01/09/12, Heater warranty to 15 years 01/02/2012.

TERMS AND CONDITIONS OF SALE AND LIMITED WARRANTY Doc.#01-00-015

- Buyer's order will constitute an offer in accordance with the terms hereof and such offer, upon acknowledgment of Seller, will constitute the agreement between Buyer and Seller. Buyer's order after such acknowledgment by Seller will not be subject to cancellation, change or reduction in amount, or suspension by Buyer of deliveries, unless prior to such action Buyer has obtained Seller's written consent. Notwithstanding anything to the contrary in Buyer's Purchase Order or other communications, the parties agree to be bound by these Terms and Conditions. Acceptance of the product by the Buyer shall be deemed to constitute unconditional acceptance of these Terms and Conditions.
- Any of these terms, conditions and provisions of Buyer's order which are inconsistent with Seller's acknowledgment and these Terms and Conditions of Sale shall not be binding on the Seller and shall be considered not applicable to any sale so made. No waiver, alteration or modification of any of the provisions on either side of the document shall be binding upon Seller unless agreed to in writing by Seller.
- (a) All prices are F.O.B. Seller's Plant and method of delivery and routing shall be at Seller's discretion, unless specifically otherwise stated herein. Notwithstanding any agreement to pay freight, delivery of products purchased hereunder to a common carrier or licensed trucker shall constitute delivery to Buyer and be determinative of the date and time of shipment and all risk of loss or damage in transit shall be borne by Buyer. If the Buyer fails to accept the goods from the common carrier or licensed trucker, the Seller shall be entitled to claim payment from the Buyer. Seller shall arrange for storage, the risk and the cost, including insurance costs, to be borne by the Buyer (and Buyer agrees to pay such amounts upon demand) except if the failure to accept delivery is due to any of the exceptions noted in Paragraph 4.
(b) Terms of payment shall be as stated on invoice.
- It is understood that deliveries will be made in accordance with Seller's regular production schedule. Every reasonable effort will be made to meet the Buyer's required delivery dates but Seller will not be liable for damages or be deemed to be in default by reason of any failure to deliver or delay in delivery due to any preference, priority, allocation or allotment order issued by the Government, whether Federal, State or local, or causes beyond its control including but not limited to, Acts of God or a public enemy, acts of Government, fires, floods, epidemics, quarantine restrictions, strikes, lockouts, freight embargoes, severe weather, unavailability of materials or shipping space, delays of carriers or suppliers or delays of any subcontractors. Should delay in delivery be caused by any of the circumstances mentioned in this paragraph, such extension of the delivery period shall be granted as is reasonable under the circumstances of the case. Should delay be caused by an event not specifically mentioned in this paragraph, damages will be limited to cancellation of the purchase order without penalty, and refund of any monies deposited or prepaid on the purchase order with no liability for any consequential or incidental damages.
- Seller reserves the right to increase the prices prior to Seller's acceptance of order and/or after expiration of any price quoted by Seller.
- Unless otherwise stated in writing, Seller's prices do not include sales, excise, value-added or other taxes. Consequently, in addition to the price specified herein, the amount of any present or future sales, use, excise, value-added or other tax applicable to the manufacture, sale, purchase or use of the products hereunder shall be paid by Buyer, or in lieu thereof, Buyer shall provide Seller with a valid tax exemption certificate acceptable to the taxing authorities.
- Seller reserves the right, at any time, to revoke any credit extended to Buyer because of Buyer's failure to pay for any products when due or for any other reason deemed good and sufficient by Seller and in such event, all subsequent shipments shall be paid for prior to at delivery at Seller's option.
- (a) SELLER'S LIABILITY SHALL BE LIMITED TO SELLER'S STATED SELLING PRICE PER UNIT OF ANY DEFECTIVE GOODS AND SHALL IN NO EVENT INCLUDE BUYER'S MANUFACTURING COSTS, LOST PROFITS, GOODWILL, OR ANY OTHER SPECIAL, INDIRECT, INCIDENTAL OR CONSEQUENTIAL DAMAGES, ARISING OUT OF THE AGREEMENT, THIS CONTRACT, THE SALE OF THE PRODUCTS TO THE BUYER OR THE USE OR THE PERFORMANCE OF THE PRODUCTS. Seller may at its discretion repair, replace or give the Buyer credit (pro-rated) for such defective products.
(b) Notwithstanding anything herein to the contrary, Seller shall have no liability for alleged defects with the products which are not specified in written notice from the Buyer to the Seller within thirty-six (36) months from the date of shipment of machines. Seller shall pass to Buyer any warranty received by Seller from the manufacturer of Limited Life Components, which in most cases is 12 to 18 months.
(c) Seller shall have no liability under this Limited Warranty unless Buyer has paid in full for the products. Further, this Limited Warranty is expressly contingent on Buyer's delivery to Seller, all costs prepaid, the defective part(s) within thirty-six (36) months of shipment to Buyer, together with a written statement specifying the alleged defect(s). Any replacement part(s) shall be shipped to Buyer on a C.O.D. basis.
(d) SELLER SPECIFICALLY EXCLUDES ALL WARRANTIES, EXPRESSED, IMPLIED OR OTHERWISE, EXCEPT AS STATED EXPLICITLY IN THESE TERMS AND CONDITIONS OF SALE. SELLER DISCLAIMS THE WARRANTY OF MERCHANTABILITY AND FITNESS FOR A PARTICULAR PURPOSE.
- The remedies herein reserved by Seller shall be cumulative and in addition to any other legal remedies. No waiver of a breach of any portion of this contract shall constitute a waiver of continuing or future breach of such provision or of any other provisions hereof.
- These Terms and Conditions constitute the entire agreement of the parties. No amendments, changes, revisions or discharges hereof in whole or in part shall have any force or effect unless set forth in writing and signed by the parties hereto. This contract shall not be assignable by Buyer voluntarily by operation of law or otherwise without Seller's written consent.
- This contract shall be governed and shall be construed according to the domestic laws of the Commonwealth of Pennsylvania.
- Anything herein to the contrary notwithstanding, any action for alleged breach by Seller of the contract between the parties, including but not limited to any action for breach of the warranties herein set forth, shall be barred unless commenced by Buyer within one (1) year from the date such cause of action accrued.
- This agreement shall inure to the benefit of and be binding upon the parties hereto, their respective successors and permitted assigns.
- All notices required by this contract to be given by either party shall be sent in writing or by facsimile and shall be addressed to the last known address of such other party. Notices shall be deemed to have been received on the fifth business day following deposit in the mail.

