

TrueVIS

LG-640/LG-540/LG-300

User's Manual

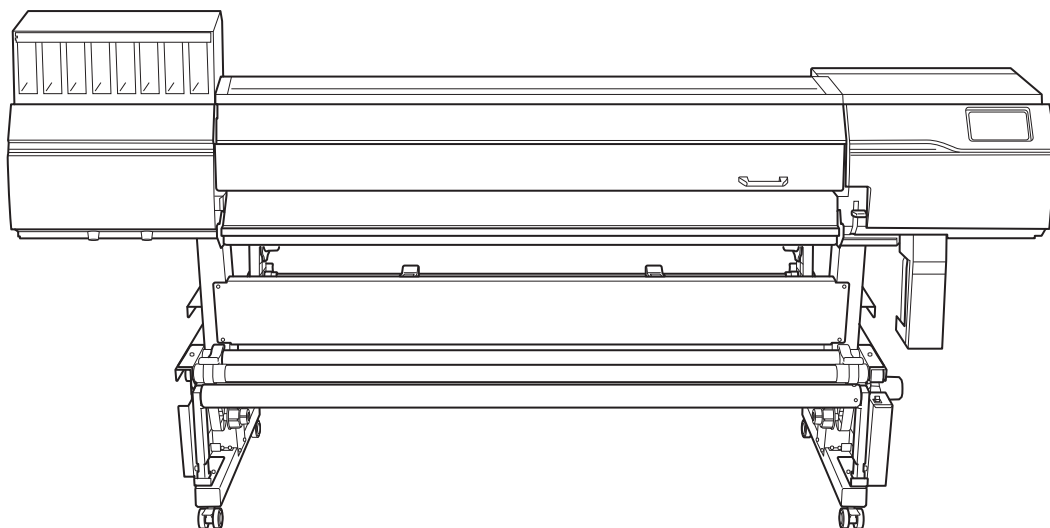

Thank you very much for purchasing this product.

- To ensure correct and safe usage with a full understanding of this product's performance, please be sure to read through this manual completely.
- Unauthorized copying or transferal, in whole or in part, of this manual is prohibited.
- The specifications of this product and the contents of this operation manual are subject to change without notice.
- The operation manual and the product have been prepared and tested as much as possible. If you find any misprints or errors, please inform us.
- Roland DG Corporation assumes no responsibility for any direct or indirect loss or damage that may occur through use of this product, regardless of any failure to perform on the part of this product.
- Roland DG Corporation assumes no responsibility for any direct or indirect loss or damage that may occur with respect to any article made using this product.

FA04332
R5-240830

<https://www.rolanddg.com/>
Copyright © 2023 - 2024 Roland DG Corporation

Contents

Basic Handling Methods	8
Basic Information	9
Part Names and Functions	10
Printer Unit	10
Take-up Unit	15
Operation Panel	16
About the Media Used	22
Types of Media	22
Conditions for Usable Media	23
Take-up Unit	24
Take-up Unit Use Conditions	24
About the Paper Tube	24
Drain Bottle	25
Removing the Drain Bottle	25
Basic Operations	26
Power Supply Operations	27
Turning the Power On	27
Turning the Power Off	28
Precautions When Operating the Power Supply	29
Sleep Mode (Power-saving Feature)	30
Setup of New Media	31
Setup of Roll Media	31
Setup of Sheet Media	56
Setup of Registered Media	70
Setup of Roll Media	70
Setup of Sheet Media	93
Checking before Output	105
LAN (Local Area Network) Settings	105
Preventing Sedimentation in Inks	106
Pausing and Canceling Output	107
Pausing and Resuming Output	107
Canceling Output	108
Separating the Media	109
Removing Media from the Take-up Unit	111
Replacing Ink	113
Out-of-ink Warnings	113
Ink Replacement Method	114
Preventing Sedimentation in Inks	118
Replacing the Cleaning Liquid	119
Out-of-cleaning-liquid Warnings	119
Cleaning Liquid Replacement Method	120
Output Method	123
Preparations for Output and Output Methods	124
Preparations before Daily Operations	125
Checking the Daily Workflow	125
Manual Cleaning Method	126
Printing Method	132
Preparations for Printing Output	132
Starting Output	136
Cutting Method	138
Preparations for Cutting Output	138

Starting Output	142
Printing and Cutting Method	143
Preparations for Printing and Cutting Output	143
Starting Output	150
How to Cut with Crop Marks	152
Preparations for Output with Crop Marks	152
Starting Output with Crop Marks	159
Preparations for Cutting Output	161
Starting Cutting Output	164

Optimizing Quality and Efficiency 165

Optimizing the Output Quality	166
Using the Correction Functions	167
Automatically Making Required Adjustments	167
Manual Adjustment: Reducing Horizontal Bands (Feed Correction)	168
Manual Adjustment: Adjusting the Misalignment of the Ink Landing Position (Media Gap Adjustment)	170
Configuring Settings to Match the Properties of the Media	172
Changing the Print Head Height	172
Using Media That Wrinkles Easily/Does Not Move Smoothly	174
Setting the Take-up Unit	175
Preventing Misaligned Media	177
Use Middle Pinch Rollers When Pulling Back or Feeding Media	177
Heating the Media to Prevent It from Coming Loose	178
Setting the Standby Heater Temperature	179
Setting the Output Heater Temperature	181
Accurately Adjusting the Cutting Settings	183
Fine-tuning the Cutting Conditions	183
Accurately Adjusting the Cutting-in Amount	185
Making Adjustments When Cutting the Print Surface	186
Performing Distance Correction during Cutting	189
Cutting to Make It Possible to Cut Corners Attractively (Over Cut)	190
Prioritizing the Cutting Settings of This Machine over the Software RIP Settings	192
Accurately Adjusting the Settings for Printing and Cutting	193
Correcting the Misalignment of Printing and Cutting	193
Correcting the Misalignment of the Printing and Cutting Positions during Cutting	196
Accurately Adjusting the Settings for Cutting with Crop Marks	198
Correcting the Misalignment of Printing and Cutting with Crop Marks (Concurrent Test for Printing and Cutting with Crop Marks)	198
Correcting the Misalignment of Printing and Cutting with Crop Marks (Separate Test for Printing/ Cutting with Crop Marks)	201
Correcting the Reading Sensor	206
Avoiding Printing Cancellation Due to Cleaning	207
Cleaning during Printing	207
Optimizing Work Efficiency	210
Managing the Media Settings	211
Changing the Media Settings	211
Checking the Registered Media Settings	213
Changing the Media Name	215
Duplicating Media Settings	216
Duplicating Media Settings for Cutting	217
Deleting Media Settings	218
Adjusting the Output-start Location	219
Setting the Base Point	219
Reducing Output Time	221
Speeding Up Output for Narrow Media	221
Other Useful Functions	222

Performing Printing Tests Arranged Horizontally	222
Optimizing Operation Management	223
Managing the Operations Appropriately and Efficiently	224
Setting the Current Date/Time and Using It for Maintenance	224
Checking the Remaining Media	225
Showing/Hiding Notifications	227
Displaying the Remaining Time until Cleaning Is Performed	228
Setting the Activation Interval for Sleep Mode (Power-saving Feature)	230
Managing the Basic Settings of the Printer	231
Changing the Display Language	231
Changing the Units of Measurement	232
Viewing Printer Information	233
Viewing Network Information	234
Adjusting the Brightness of the Operation Panel	235
Turning Off Operation Panel Sounds	236
Returning All Settings to Factory Defaults	237
Maintenance	238
Introduction	239
Important Notes on Handling and Use	240
Printer	240
Ink Cartridges	240
Basic Maintenance Knowledge	241
Types and Timing of Maintenance	241
Measures When the Printer Is Not in Use for a Prolonged Period	243
Regular Maintenance	244
Print Head Check before Printing	245
Performing a Nozzle Drop-out Test	245
Cleaning the Machine	246
Cleaning the Media Path	246
Cleaning the Cutting Carriage Roller	247
Cleaning around the Print Heads	248
Manual Cleaning Method	249
Consumable Products and Parts Related to Manual Cleaning	255
Cleaning That Must Be Performed Once a Month or More	256
When UV-LED Device Cleaning Is Necessary	256
How to Clean the UV-LED Devices	257
Disposing of Discharged Fluid	260
Precautions for Disposing of Discharged Fluid	261
If the Discharged Fluid Disposal Message Appears	262
Advanced Maintenance	264
When Dot Drop-out or Dot Displacement Occurs	265
Normal Cleaning Method	265
When Normal Cleaning Is Not Effective	267
Medium Cleaning Method	267
Powerful Cleaning Method	269
When Uneven Color Issues Occur with White Ink	271
Ink Circulating Method	271
Method for Eliminating Uneven Color Issues with Powerful Cleaning	272
Method for Ink Renewal Inside Damper	273
Handling Severe Dot Drop-out, Dot Displacement, and Uneven Colors	276
Ink Renewal Method	276
Partially Restricting the Print Heads Used for Printing	280

Emergency Measure) Cleaning the Print Head Surface	282
When the Operation Panel Is Dirty	285
Operation Panel Cleaning Method	285
Replacing Consumable Parts	286
Replacing Parts for Maintenance	287
Replacing the Wiper	287
Replacing the Print Head Caps	290
Replacing the wiper cleaner	292
Replacing the UV Mist Filters	294
Replacing the Flushing Sponge	296
Replacing the Blade/Separating Knife	298
Replacing the Blade	298
Replacing the Separating Knife	304
Consumable Parts That Require Inquiries before Replacement	306

Troubleshooting Methods **307**

Output Quality Problems	308
Printed results are coarse or contain horizontal stripes	309
Do the print heads cause dot drop-out?	309
Is the print head height appropriate?	309
Have you carried out [Feed Correction]?	309
Have you carried out [Media Gap Adjustment] (ink landing position correction)?	309
Is the printer installed in a level and stable location?	310
Is the print mode suitable?	310
Is the media loaded correctly?	310
Are the [Media Settings] appropriate?	310
The media becomes soiled when printed	311
Do the print heads come into contact with the media?	311
Are the print heads dirty?	311
Are the pinch rollers or the media clamps dirty?	311
Colors are unstable or uneven	312
Did you shake the ink cartridges before installing them?	312
Are colors still uneven after mixing the ink by shaking the ink cartridges?	312
Is the media wrinkled?	312
Was printing paused partway through?	313
Was cleaning performed during printing?	313
Is the printer installed in a level and stable location?	313
Is the media loaded correctly?	313
Are the operating parameters set to appropriate values?	313
Are the [Media Settings] appropriate?	313
Are the irradiation windows of the UV-LED devices dirty?	314
Cutting Is Misaligned, Skewed, or Not Clean	315
Is the media loaded correctly?	315
Are the settings for the cutting conditions appropriate?	315
Is the length of output too long?	315
Are you using media that exhibits large expansion and contraction?	315
Is the setting for the [Cutting Distance Correction] menu item (under [Cutting Settings]) correct?	315
Are the pinch rollers placed on the proper locations?	316
Have you corrected the misalignment of printing and cutting?	316
Is the blade holder installed appropriately?	316
Is the blade worn?	316
Is there any buildup of pieces of material or dust inside the blade holder?	316
Problems in Cutting with Crop Marks	317
Automatic Detection of Crop Marks Fails	318
Are the margins from the pinch rollers to the crop marks too small?	318

Is the media wrinkled or warped?	318
Is the media size too large?	318
Are you using media that is likely to reflect light?.....	318
Are you using transparent media?	318
Printing and Cutting Are Misaligned.....	319
Have you corrected the misalignment of printing and cutting with crop marks?	319
Media Feed Problems	320
Media Wrinkles or Shrinks	321
Is the media loaded and set up straight and securely?	321
Was loaded media allowed to stand for some time?	321
Are the media clamps installed?	321
Was the media loaded while the front heater was hot?	321
Is the temperature of the front heater too high?	321
Is the humidity of the room too high?	321
Is the media sagging?	321
Media Feeding Is Not Straight.....	322
Is the media loaded and set up straight and securely?	322
Media Feeding Is Not Smooth	323
Is some other object coming into contact with the media?	323
Is the media too thick?	323
Are the grit rollers dirty?.....	323
A Media Jam Occurs!	324
Is an error message displayed?	324
Is the media warped or wrinkled?	324
Is the height of the print heads too low?	324
Are the grit rollers dirty?.....	324
Are the media clamps installed?	324
Is the media loaded and set up straight and securely?	324
Is some other object coming into contact with the media?	325
Is the media too thick?	325
Machine Problems	326
The Print Heads Do Not Move	327
What to Do First	327
If the Print Heads Still Do Not Move	327
The printer unit does not run	329
Is the power switched on?.....	329
Is [Output possible.] displayed?	329
Are any covers open?	329
Is the message [Output is currently paused.] displayed on the screen?.....	329
Is a message displayed on the screen?	329
Are the cables connected?	329
Is the LAN routing appropriate?	330
Are the LAN settings correct?.....	330
Did the software RIP end abnormally?	330
Is an [Ink Cartridge Error] displayed?	330
The Front Heater Does Not Become Hot	332
Has the media been set up?	332
Is [Front Heater] turned on?	332
Is the temperature of the room too low?	332
Cannot Separate the Media	333
Is the separating knife installed?.....	333
Messages on the Operation Panel.....	334
Messages	335
[When output, cleaning, and other operations are completed, discard the discharged fluid.]	335
[The time for manual cleaning has arrived.].....	335
[The time for wiper replacement has arrived.]	335

[The time for cap replacement has arrived.]	335
[The time for wiper cleaner replacement has arrived.]	335
[The time for UV mist filter replacement has arrived.]	336
[The time for flushing sponge replacement has arrived.]	336
[Print head protection mode has activated.]	336
[Replace the cleaning liquid pouch.]	336
[Install the cleaning liquid pouch.]	337
[Remaining cleaning liquid level low.]	337
[The time for ink mixing has arrived.]	337
[Operation of the take-up unit stopped.]	337
[Place the middle pinch rollers over all the grit rollers.]	338
[Install the media clamps correctly.]	338
[Media clamps could not be detected.]	338
[The LAN cable is not connected.]	339
[Connection is requiring too much time. Manually setting the IP address will improve the connection speed.]	339
[There is ink that has expired.]	339
[The media could not be detected automatically. Manually set the printing area.]	339
Error Messages	341
[Ink Cartridge Error]	341
[Cover Open Error]	341
[Media End Error]	341
[Pinch Lever Error]	341
[Media Loading Error]	342
[Drain Bottle Error]	342
[Crop Mark Detection Error]	342
[Unable to Fill Wiper Cleaning Liquid]	343
[Pinch Roller Error]	343
[Print Head Height Mismatch]	343
[Insufficient Media Width]	343
[Motor Error]	344
[Print Head Dry-out Error]	344
[Low Temperature Error]	344
[High Temperature Error]	344
[Pump Stop Error]	345
[Cleaning Error (Ink Cartridge)]	345
[Cleaning Error (Drain Bottle)]	345
[Take-up Unit Communication Error]	346
[Service Call]	346
[Software error]	346

Appendix..... 347

Operations When Moving the Unit	348
Preparing to Move the Machine	349
Step 1: Removing Media and the Blade Holder	349
Step 2: Circulating the Ink (Only When Using White Ink)	351
Step 3: Discarding the Discharged Fluid	352
Step 4: Secure the print heads in place using the retainer.	354
Step 5: Reinstalling the Machine	356
Main Specifications	358
Printing/Cutting Area	359
Maximum Area	359
Maximum Printing Area When Using Crop Marks	360
Media Separation Location during Continuous Printing	361
About the Blade	362
Memo	363

About this Manual.....	364
Software.....	365

Basic Handling Methods

Basic Information

Part Names and Functions.....	10
Printer Unit.....	10
Take-up Unit	15
Operation Panel	16
About the Media Used	22
Types of Media	22
Conditions for Usable Media	23
Take-up Unit.....	24
Take-up Unit Use Conditions.....	24
About the Paper Tube.....	24
Drain Bottle	25
Removing the Drain Bottle.....	25

Part Names and Functions

Printer Unit

Front

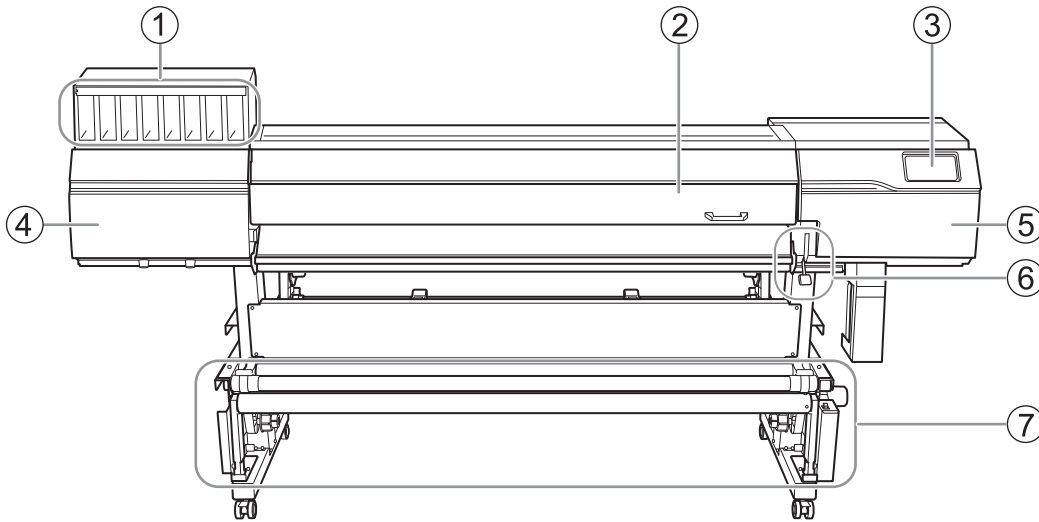

No.	Name	Function overview
①	Ink slots	Store the ink cartridges. Insert ink cartridges in which ink pouches have been loaded.
②	Front cover	Prevents contact with the print heads and other such fast-moving parts when the machine is operating. This cover also blocks ultraviolet light from the UV lamp and prevents dust from entering the machine. Keep this cover closed when not loading media or performing maintenance.
③	Operation panel	Used to perform all machine operations including printing, setup, and maintenance. P. 16 Operation Panel
④	Left cover	Provides access to the interior of the left side of the machine. Open this cover when performing maintenance such as cleaning around the print heads.
⑤	Right cover	Provides access to the interior of the right side of the machine. Open this cover when performing maintenance such as cleaning and part replacement.
⑥	Loading lever (front)	Secures the media in place and releases it. Use this lever when working at the front of the machine. Lowering the lever secures the media in place.
⑦	Take-up Unit	Takes up the media after printing. This prevents the printed media from touching the floor.

Rear

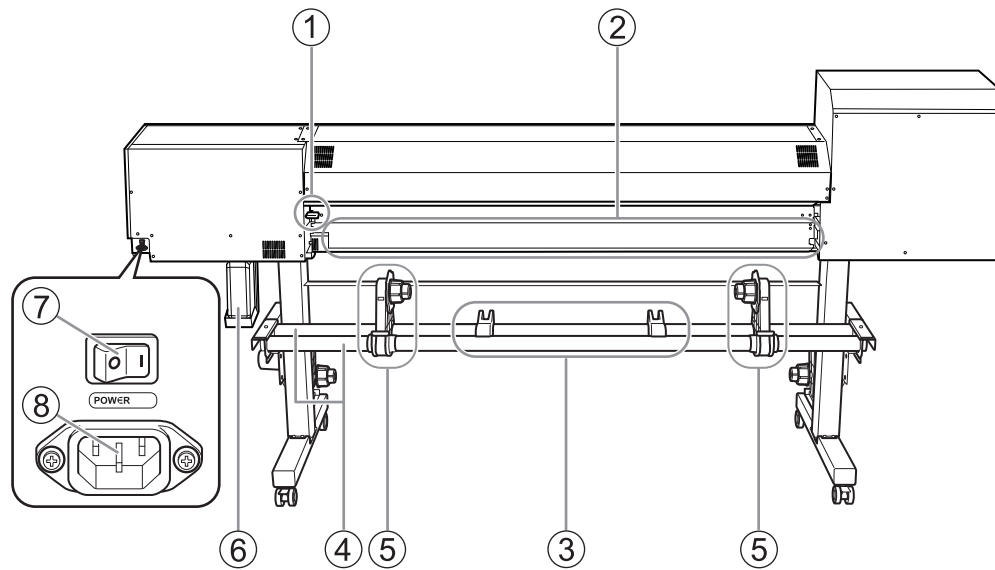

No.	Name	Function overview
①	Loading lever (rear)	Secures the media in place and releases it. Use this lever when working at the back of the machine. Lowering the lever secures the media in place.
②	Rear UV shield	Blocks the light from the UV lamp during printing. Open this shield when you load the media and close it when you are finished loading the media. Printing is not possible with the UV shield open.
③	Media stays	Temporarily hold the roll media in place. Temporarily place the roll media on these stays when loading this media on the media holders.
④	Shafts	Used to adjust the positions of the media stays and media holders. The media stays and media holders are moved to the left or right along this shaft to match the width of the media.
⑤	Media holders	Hold the roll media. Fit the paper tube of the media onto the end caps of the media holders.
⑥	Drain bottle	Accumulates the discharged cleaning liquid and ink. When discharged fluid is nearly overflowing from the bottle, an error is displayed and printing is not possible.
⑦	Main power switch	Switches the main power of the machine on/off.
⑧	Power-cord connector	Used to connect the power cable from which power is supplied to the machine.

Side

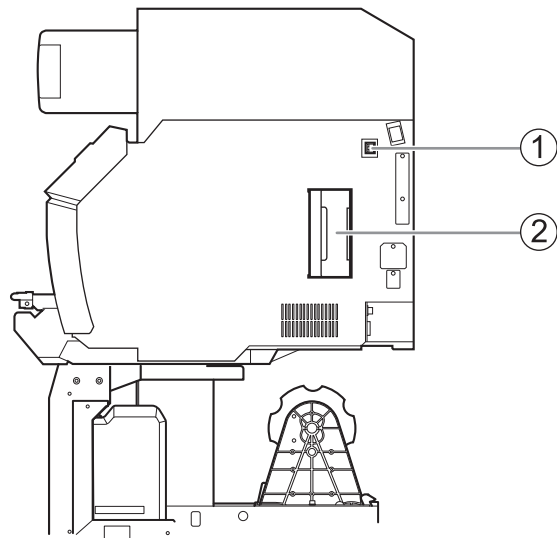

No.	Name	Function overview
①	Ethernet connector	Use this to connect an Ethernet cable.
②	Cleaning liquid slot	Stores a cleaning cartridge containing a cleaning liquid pouch.

Front Cover Interior/Print Head Area

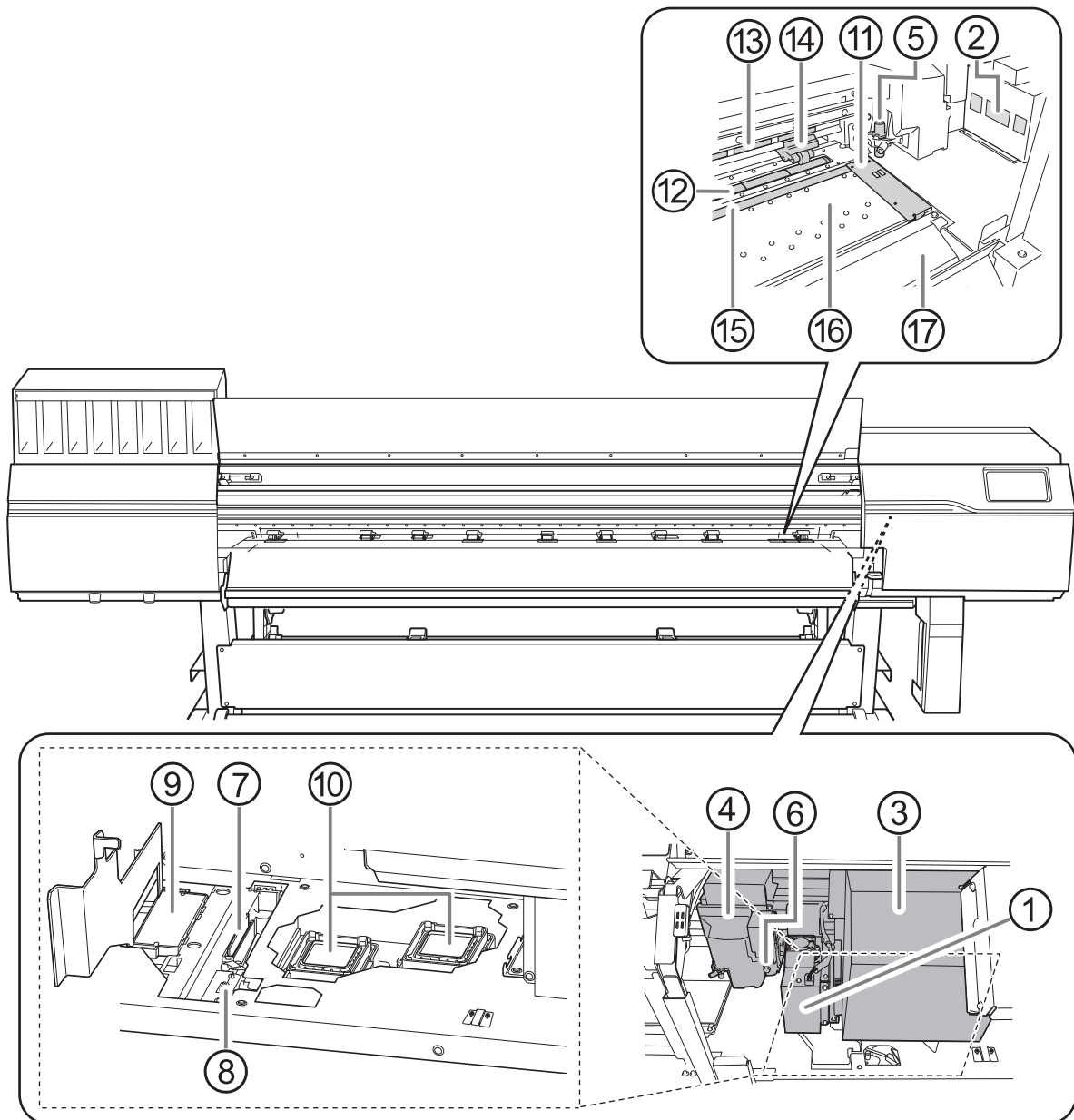

No.	Name	Function overview
①	UV-LED device	Shines the UV light on the print surface to cure the ink.
②	UV mist filters	Absorb the ink mist that flows into the UV-LED device.
③	Print-head carriage	Transports the built-in print heads and UV-LED device.
④	Cutting carriage	The blade and the separating knife are inside here. This part transports the blade and separating knife to the left and right.
⑤	Blade holder	Holds the blade used during cutting.
⑥	Separating knife	The knife used to separate the media.
⑦	Wiper	Cleans the print heads, removing dirt and excess ink that have adhered to these heads.
⑧	Wiper cleaner	Removes ink and dirt that have adhered to the wiper.
⑨	Flushing sponge	Absorbs ink flushed from the print heads.

No.	Name	Function overview
⑩	Print head caps	Prevent the print heads from drying out by sealing the print heads to protect the ink emission surface when the print heads are at the right side of the machine, such as when waiting for printing.
⑪	Media clamp	Each clamp holds down the left or right edge of the media, keeping the media from coming loose and preventing fuzz on the cut edge of the media from touching the print heads.
⑫	Grit roller	Transports the media.
⑬	Grit pattern	This indicates the location of a grit roller. When loading media, be sure to place the pinch rollers within the ranges indicated by these patterns.
⑭	Pinch roller (left pinch roller, right pinch roller, and middle pinch roller)	Each pinch roller is lowered/raised according to the operation of the loading levers. Lowering a loading lever lowers the pinch rollers, clamping the media. The pinch rollers are called the left pinch roller, the right pinch roller, and the middle pinch roller according to their positions.
⑮	Blade protector	This is the path that the blade takes during cutting. It protects the tip of the blade.
⑯	Platen	This is the path over which the media passes. A suction fan that keeps the media from coming loose is built in.
⑰	Apron	This is the path over which the media passes. The apron has a built-in heater that heats the media and prevents it from coming loose.

If a Cover Opens during Operation

If the front cover, left cover, right cover, or rear UV shield (hereinafter these items are all referred to as the "cover") opens during an output operation, the machine makes an emergency stop. When an emergency stop occurs, a message prompting you to close the cover appears on the screen. Close the covers as directed in the instructions shown on the screen.

When the cover is closed, you will be able to continue the operation.

If you cannot continue the operation even after you close the cover, a nonrecoverable error may have occurred.

RELATED LINKS

- [P. 341 Error Messages](#)

Take-up Unit

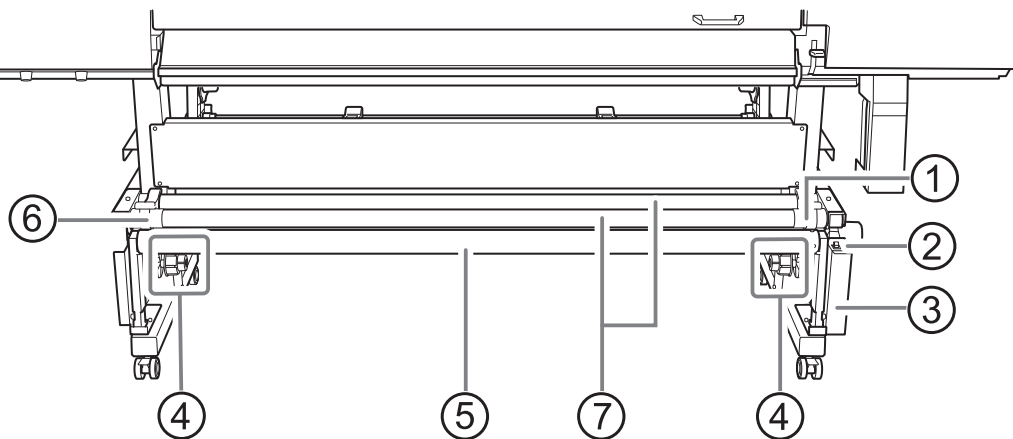

No.	Name	Function overview
①	Motorized media holder	Holds the right side of the paper tube for take-up. Move this part to the right or left to match the width of the paper tube and insert this tube to the appropriate positions on the end caps. The media holder's built-in motor rotates the end caps to take up the media.
②	MANUAL switch	Use this switch when taking up the media. Use it when you cannot reach the operation panel.
③	Control box	This controls the media take-up.
④	End caps	Hold the paper tube for take-up. Insert this tube to the appropriate positions on the end caps.
⑤	Dancer roller	Adjusts the tension applied to the media to ensure there is no slack in the media and that it is not too tight. Lower this roller to the rear when not using the take-up unit.
⑥	Left media holder	Holds the left side of the paper tube for take-up. Move this part to the right or left to match the width of the paper tube and insert this tube to the appropriate positions on the end caps.
⑦	Shafts	Adjust the position of the media holders. The media holders are moved to the left or right along these shafts to match the width of the media.

Operation Panel

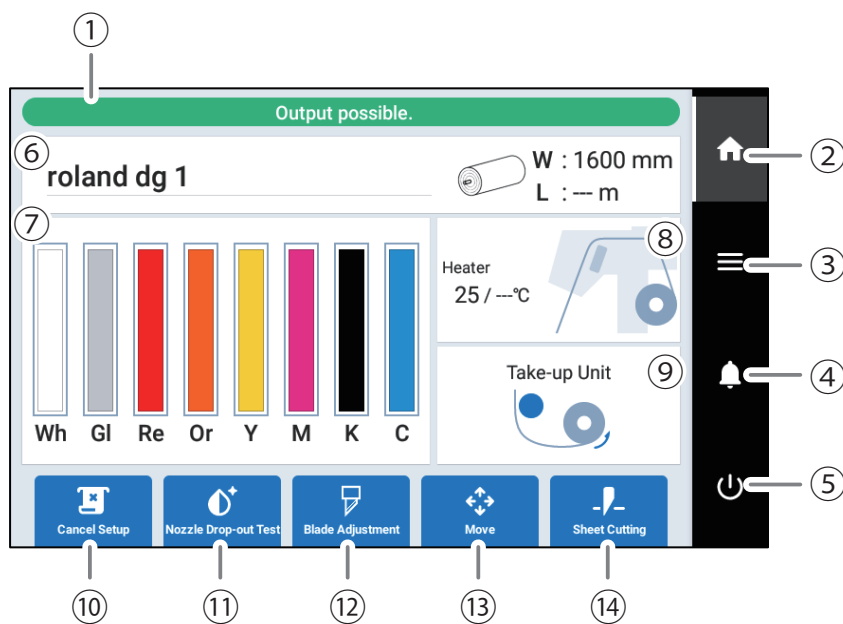

No.	Name	Details
①	Status bar	Displays the printer status and indicates the next operation.
②	Home	Displays the home screen.
③	Menu	Displays various setting menus.
④	Notifications	Displays important information. When there are notifications, their number is displayed next to the icon.
⑤	Sub power	Controls the power to the operation panel.
⑥	Media information	Displays the media name, media width (W), and remaining media (L). This information is only displayed when media has been set up and there is media remaining. Tap the media width (W) or the remaining media (L) to display the [Remaining Media Management] screen on which you can set the remaining media. P. 225 Checking the Remaining Media
⑦	Amount of ink remaining	Displays the amount of ink remaining in each cartridge. If it is time to replace a color,  is displayed next to the corresponding ink cartridge. Tap this icon to display the detailed information for the ink.
⑧	Front heater temperature	The front heater temperature is displayed as current temperature/set temperature. In the figure shown here, the heater is off. If it is on, the heater part is displayed in red. Tap one of these items to display a screen for: <ul style="list-style-type: none"> • <u>When media has not been set up</u> You can set the [Standby Heater Temperature]. • <u>When media has been set up</u> You can set the [Heater Temperature].
⑨	Take-up Unit	Displays the status of the take-up unit. Tap this icon to display the [Take-up] screen on which you can set the [Take-up Method] and [Take-up Direction].
⑩	[Setup]/[Cancel Setup]	Starts/cancels the setting up of the media. P. 31 Setup of New Media P. 70 Setup of Registered Media

No.	Name	Details
⑪	[Cleaning]/[Nozzle Drop-out Test]	Displays the menu related to the printing test and cleaning for the nozzle drop-out check.
⑫	[Blade Adjustment]	Sets cutting conditions. This is only enabled when media has been set up.
⑬	[Move]	Feeds the media and moves the carriage. You can also set the position moved to as the right edge of the output area (the base point). P. 219 Adjusting the Output-start Location
⑭	[Sheet Cutting]	Activates the separating knife, allowing the media to be separated and perforated lines to be cut. An example application is that cutting perforated lines allows the media to be separated after it is taken up.

Menu List

Tap  to display the list of operations.

MEMO

[Media Settings] only appears when media has been set up.

Level 1	Level 2	Level 3	Level 4	Details	
[Media Settings] ^{*1}	[List of Media Settings]			Lists the settings of the media that has been set up. Tap a setting to move to a screen for changing this setting.	
	[Printing Settings]	[Print Head Height]		Checks/changes the head height.	
		[Batch Automatic Correction]		Adjustments are performed in the following order: [Multi Sensor Adjustment], [Media Gap Adjustment], then [Feed Correction].	
		[Feed Correction]	[Simple Correction (Auto)]		Adjusts the media feed amount during printing. With [Simple Correction (Auto)], a test pattern is printed and then read with a sensor to automatically set the correction value.
			[Detailed Correction (Manual)]		Adjusts the media feed amount during printing. With [Detailed Correction (Manual)], a test pattern is printed, and then the correction value is entered manually after the printed correction value is checked visually.
		[Media Gap Adjustment]	[Simple Correction (Auto)]		Corrects the ink landing position. With [Simple Correction (Auto)], a test pattern is printed and then read with a sensor to automatically set the correction value.
			[Detailed Correction (Manual)]		Corrects the ink landing position. With [Detailed Correction (Manual)], a test pattern is printed, and then the correction value is entered manually after the printed correction value is checked visually.
	[Cutting Settings]	[Blade Adjustment]		Sets cutting conditions such as [Blade Force] and [Cutting Speed].	
		[Print & Cut Position Adjustment]		Corrects misalignment in the printing position and the cutting position during printing and cutting.	
		[Crop Cut Position Adjustment]		Corrects misalignment in the crop mark positions and the cutting position when cutting with crop marks.	
		[Cutting Distance Correction]		Corrects misalignment in the cutting line length due to changes in the media movement distance.	
		[Over Cut]		Cutting the corners of the border of the cutting line slightly longer makes it possible to cut the corners attractively.	
[Media Settings] ^{*1}	[Heater Temperature]			Sets the front heater temperature when media has been set up.	
	[Other Media Settings]	[Multi Sensor Adjustment]		Optimizes the status of the multi sensor used when reading crop marks and with the automatic correction function.	
		[Media Suction Force]		Adjusts the media suction force of the platen.	
		[Printing Movement Range]		Select the carriage movement range during printing from [Output Data Width], [Media Width], and [Full Width].	
		[Middle Pinch Auto Raise/Lower]		Causes the middle pinch rollers to go up automatically during pullback printing or printing and cutting.	
[Batch Media Settings]			The minimum settings required for media setup can be configured by following the on-screen instructions on the operation panel.		

Level 1	Level 2	Level 3	Level 4	Details
[Media Management]				<p>Displays a list of registered media. Up to 50 media names can be saved, and the following operations on media settings are possible.</p> <ul style="list-style-type: none"> • Checking setting details in a list • Changing media names • Copying media settings • Deleting media settings
[Cleaning]	[Printing Test]			<p>Before printing, use [Nozzle Drop-out Test] to check whether ink is discharged from the print heads correctly. If nozzle drop-out is present, perform cleaning appropriate for the severity of the drop-out. If faulty ink discharge cannot be improved, the problematic nozzle can be identified with [Nozzle Mask Test], making it possible to stop using this nozzle.</p>
	[Normal Cleaning]			<p>If dot drop-out or dot displacement occurs, select the nozzle from [Group A], [Group B], and [Both], and then perform cleaning of the print heads. If the problem cannot be fixed, perform more powerful cleaning. [Powerful Cleaning] also has the effect of improving uneven colors with white ink.</p> <p>If the media has already been set up, the [After cleaning, perform a printing test.] menu appears. When this is turned on, a printing test is performed after cleaning.</p>
	[Medium Cleaning]			
	[Powerful Cleaning]			
		[Manual Cleaning]		
[Maintenance]	[Wiper Replacement]			<p>Replaces the wiper used in cleaning the print heads.</p>
	[Blade Replacement]			<p>Replaces the blade used in cutting.</p>
	[Separating Knife Replacement]			<p>Replaces the separating knife used in media separation.</p>
	[Cap Replacement]			<p>Replaces the print head caps, which are used to protect the print heads from drying out and from dust.</p>
	[Wiper Cleaner Replacement]			<p>Replaces the wiper cleaner used to wipe away dirt from the wiper.</p>
	[UV Mist Filter Replacement]			<p>Replaces the UV mist filters used to absorb ink mist.</p>
	[Flushing Sponge Replacement]			<p>Replaces the flushing sponge used to absorb the flushed ink.</p>
	[Ink Renewal]			<p>Perform this operation when ink discharge issues or uneven colors are not resolved even after [Normal Cleaning], [Medium Cleaning], [Powerful Cleaning], and [Manual Cleaning]. However, this operation consumes a large amount of ink and may damage the print heads, so do not perform it more than necessary.</p>
	[Ink Renewal Inside Damper] ^{*2}			<p>Use this operation to stabilize output when uneven color issues with white ink are not resolved even after shaking the ink cartridge to mix the ink or performing [Ink Circulation]. However, this operation consumes a large amount of ink and may damage the print heads, so do not perform it more than necessary.</p>
	[Ink Circulation] ^{*2}			<p>Circulates ink to prevent uneven color issues with white ink.</p> <p>If the media has already been set up, the [After ink circulation, perform a printing test.] menu appears. When this is turned on, a printing test is performed after [Ink Circulation].</p>
	[Drain Bottle]			<p>A message appears when discharged fluid has collected in the drain bottle. Use this menu item to discard this fluid.</p>

Part Names and Functions

Level 1	Level 2	Level 3	Level 4	Details
[Preferences]	[Media Edge Detection]			Sets whether to detect the leading and trailing edges of the media. When using transparent media, whose edges cannot be detected, the media can be set up without detecting the edges by selecting [Disable].
	[Take-up]			Sets the [Take-up Method] and [Take-up Direction] for the take-up unit.
	[Remaining Media Management]			Sets the amount of remaining media that has been set up and displays this amount. This amount can also be printed on the media.
	[Skewing Correction Support at Setup]			Provides support, preventing skewed installation of the media by making a sound and operating an automatic suction fan during setup.
	[Printing Test Position]			Sets the direction for test pattern printing: [Feed] or [Scan].
	[Perforated Sheet Cutting]			Sets the perforated sheet cutting conditions.
	[Standby Heater Temperature]			Sets the front heater temperature when media has not been set up.
	[Prefeeding at Output]			Prefeeds the media when it is fed out, such as during cutting, preventing the pulling of the media with undue force.
	[Priority for Cutting Settings]			Sets whether to prioritize the cutting settings of the machine or the software RIP.
	[Ink Circulation Interval] ^{*2}			Sets the frequency of white ink circulation.
	[Notifications On/Off]			When this is set to on, notifications are displayed at the appropriate times. <ul style="list-style-type: none"> • [Ink Mixing Notification]^{*2} • [Middle Pinch Roller Placement Notification] • [Media Clamp Placement Notification] • [Ink Expiration Date Notification]
	[Time Remaining before Cleaning during Printing]			Sets whether to display the remaining time until cleaning is performed automatically. When this is turned on, the Cleaning and Count Clear menu will be displayed on the setting screen and the remaining time until cleaning is performed will be displayed on the home screen.
	[Sleep Time]			Sets the time until sleep mode (the state in which the power-saving features operate) activates.
[Reset to Factory Defaults]			Returns all settings other than [Language] and [Units] to their factory default values.	
[System Information]	[Machine Information]			Displays the [Model], [Serial Number], [Ink Type], [Firmware Version], and [MAC Address].
	[Network]			Sets the [Obtain IP Address Automatically], [IP Address], [Subnet Mask], and [Default Gateway] to connect the machine to a computer.
	[Units]			Sets the [Length] and [Temperature].
	[Language]			Sets the language. The language can be set to Japanese, English, French, Italian, German, Spanish (Europe), Spanish (South America), or Portuguese (South America).
	[Date/Time]			Sets the current year, month, day, hour, minute, and second.
	[Screen Brightness]			Sets the brightness of the operation panel's screen.
	[Screen Operation Sound]			Turns the operation sound of the operation panel on/off.
	[License]			Displays the license information of the operation panel.

*1 This setting only appears when media has been set up.

*2 This menu item is only displayed on machines when the ink type includes white ink.

About the Media Used

Types of Media

In this manual, the paper used for output is called "media." The two main types of media used in this machine are shown below.

- Roll media: Media wound onto a paper tube
- Sheet media: Media not wound onto a paper tube such as standard-size media

Various paper types of roll media and sheet media are selectable according to your purpose. For detailed information about each media, contact your media supplier.

Conditions for Usable Media

This machine cannot print on every kind of media. When selecting media, be sure to carry out testing in advance to make sure that satisfactory printing results are obtained.

Size

	64-inch model	54-inch model	30-inch model
Width *1	335 to 1.625 mm (13.2 to 64 in.)	295 to 1.371 mm (11.7 to 54 in.)	182 to 762 mm (7.2 to 30 in.)
Cutable media thickness*1	0.08 to 0.22 mm (3.2 to 8.6 mil; depends on the material of the media)		
Maximum media thickness (including backing paper)*1	When performing printing only: 1.0 mm (39.4 mil) When performing cutting: 0.4 mm (15 mil)		
Maximum roll outer diameter	250 mm (9.8 in.)		
Paper tube (core) inner diameter	76.2 mm (3 in.) or 50.8 mm (2 in.)		

*1 Applies to both roll and sheet media

Maximum Roll Weight

- 64-inch model: 45 kg (99 lb.)
- 54-inch model: 35 kg (77 lb.)
- 30-inch model: 30 kg (66 lb.)

MEMO

If using the take-up unit, this specification depends on the conditions of the take-up unit.

Other Conditions

Media such as the following cannot be used.

- Media whose end is attached to the paper tube (core)
- Media that is severely warped or that has a strong tendency to reroll
- Media that cannot withstand the heat of the media heating system
- Media whose paper tube (core) is bent or crushed
- Media that bends under its own weight when loaded
- Media on a sagging roll
- Media that is rolled unevenly

Take-up Unit

Take-up Unit Use Conditions

Never pull the media with excessive force.

If the media is pulled with excessive force, the protection function will activate and cause an error. Make sure to observe the following to prevent the media from being pulled with excessive force.

- Do not operate the manual switch on the take-up unit while leaving media secured with the loading lever.

It may cause an error because the media is pulled with excessive force.

Never use the automatic separation function for media.

If automatic cut-off of media is set in the software RIP, the media will be cut off after each page is printed. When continually printing and taking up multiple pages, disable the automatic cut-off function in the software RIP. If the media is separated, take-up will be interrupted at that point.

MEMO

Perforated sheet cutting can be set with the software RIP. With this type of cutting, the media is not separated, so the take-up unit can be used.

About the Paper Tube

Paper tubes are consumable items.

Paper tubes are components that wear out. Although replacement timing will vary depending on use, watch the condition of the paper tube and replace at an appropriate time so that the media can be taken up in good working order.

Use the paper tube of the media you are using. To purchase the included paper tube, contact your authorized Roland DG Corporation dealer or visit our website (<https://www.rolanddg.com/>).

Drain Bottle

Removing the Drain Bottle

Do not remove the drain bottle during maintenance operations and output.

Doing so may lead to unstable machine operation or dripping discharged fluid.

Only remove the drain bottle from the machine when:

- The message [**Discard the discharged fluid.**] appears and you are disposing of discharged fluid.
- You are disposing of discharged fluid by tapping [**Maintenance**]>[**Drain Bottle**] accessed with .

Basic Operations

Power Supply Operations	27
Turning the Power On	27
Turning the Power Off	28
Precautions When Operating the Power Supply	29
Sleep Mode (Power-saving Feature)	30
Setup of New Media	31
Setup of Roll Media	31
Setup of Sheet Media	56
Setup of Registered Media	70
Setup of Roll Media	70
Setup of Sheet Media	93
Checking before Output	105
LAN (Local Area Network) Settings	105
Preventing Sedimentation in Inks	106
Pausing and Canceling Output	107
Pausing and Resuming Output	107
Canceling Output	108
Separating the Media	109
Removing Media from the Take-up Unit	111
Replacing Ink	113
Out-of-ink Warnings	113
Ink Replacement Method	114
Preventing Sedimentation in Inks	118
Replacing the Cleaning Liquid	119
Out-of-cleaning-liquid Warnings	119
Cleaning Liquid Replacement Method	120

Power Supply Operations

Turning the Power On

⚠ WARNING

Remove any loaded media or switch off the sub power when printing is not being performed. The continued application of heat at a single location may cause the release of toxic gases from the media or pose a fire hazard.

Procedure

1. Close the front cover.
2. Turn on the main power switch.

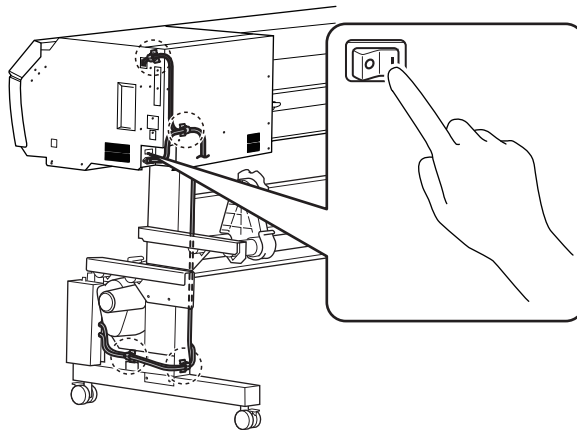

3. Tap the operation panel.

The power to the operation panel is switched on.

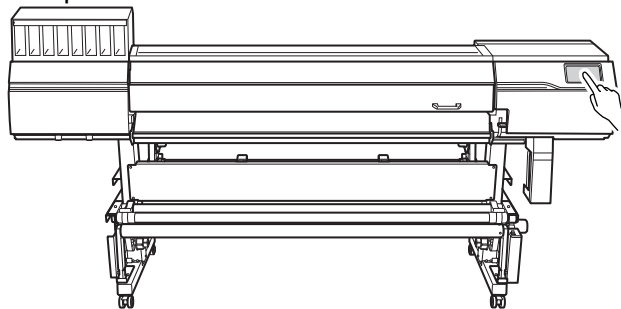

4. When instructions appear on the screen, tap the operation panel again.

Turning the Power Off

⚠ WARNING

Remove any loaded media or switch off the sub power when printing is not being performed. The continued application of heat at a single location may cause the release of toxic gases from the media or pose a fire hazard.

Procedure

1. When printing is complete, tap  on the operation panel.

The confirmation screen appears.

2. Tap [Yes].
The sub power switches off automatically.

3. Raise the loading lever and remove the media.

If you will leave the sub power on while not using the machine, set it as shown below.

- Raise the loading lever.

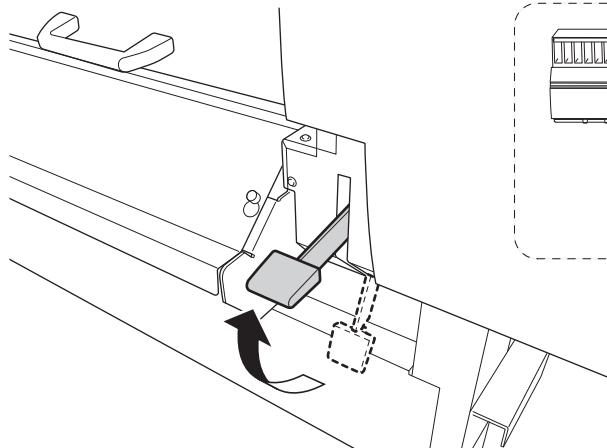

- Lower the dancer roller toward the rear.

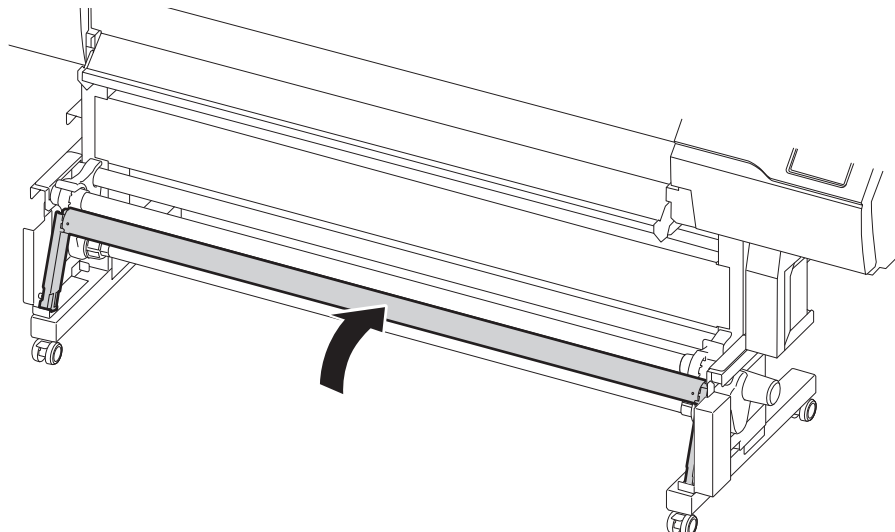

Precautions When Operating the Power Supply

Always keep the main power switched on.

Never switch off the main power. Leaving the main power enables automatic maintenance to be carried out periodically. If the automatic maintenance is not carried out, it may result in the breakdown of this machine, such as the breakdown of the print heads.

Never switch off the main power or unplug the power cord suddenly while operation is in progress.

Switching off the main power or unplugging the power cord suddenly while operation is in progress may damage the print heads. Be sure to first switch off the sub power. If the main power is accidentally switched off, immediately turn the main power and sub power back on.

Sleep Mode (Power-saving Feature)

This machine is provided with a power-saving feature that switches to a low-power "sleep mode" when a fixed interval passes with no operation. The factory default for the time after which the machine switches to sleep mode is 30 minutes. The operation panel turns off when the machine enters sleep mode. Using the operation panel or performing operations such as sending print data from the computer restores the machine to its normal mode.

This sleep mode setting can be changed. However, we recommend setting the activation time for sleep mode to 30 minutes or less to reduce power consumption and prevent problems such as overheating.

RELATED LINKS

- [P. 230 Setting the Activation Interval for Sleep Mode \(Power-saving Feature\)](#)

Setup of New Media

⚠ CAUTION

Do not touch the dancer roller needlessly.

The media take-up unit and feeder may move suddenly, which may result in injury.

Setup of Roll Media

Load the roll media on the printer. When the loading is finished, [Output possible.] is displayed as the status. This work is referred to as "Setup of Media."

⚠ CAUTION

Load the roll media correctly.

Otherwise the media may fall and cause injury.

⚠ CAUTION

The roll media is approximately 45 kg (99.21 lb.) (54-inch model: 35 kg [77.16 lb.], 30-inch model: 30 kg [66.14 lb.]).

To avoid injury, handle the roll media with care.

⚠ CAUTION

Never load media that weighs over 45 kg (99.21 lb.) (54-inch model: 35 kg [77.16 lb.], 30-inch model: 30 kg [66.14 lb.]).

The machine may fail to withstand the weight and tip over or cause the media to fall.

1. Install the media on the media holders.

The media holders of this machine are designed to be used with a paper tube (core) with an inner diameter of 2 inches or 3 inches.

⚠ WARNING

Handling roll media is an operation that must be performed by 2 persons or more, and care must be taken to prevent falls.



Attempting to lift heavy media in a manner that taxes your strength may cause physical injury. Also, if dropped, such items may cause injury.

Procedure

1. Tap  on the operation panel.

The sub power is switched on.

2. When using a take-up unit, use the following procedure to set it.

- (1) Tap .
- (2) Tap [Preferences]>[Take-up]>[Take-up Direction].
- (3) Select [Backward] or [Forward].
- (4) Tap [Save].
- (5) Tap  to go back to the original screen.

3. Open the front cover.

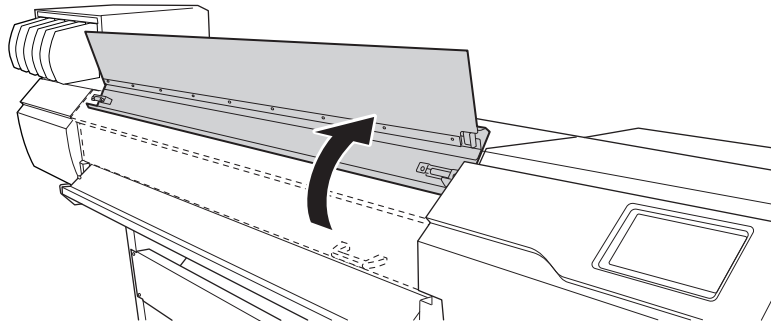

4. Move the media clamps to the outside of the grit rollers on the left and right edges respectively.

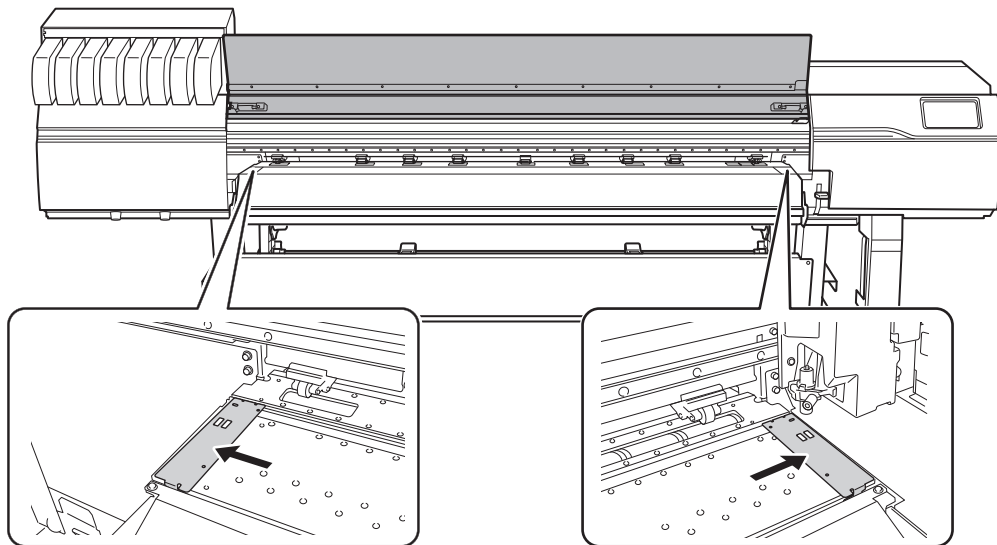

5. Move to the rear of the printer and open the rear UV shield.

- a. Open the rear UV shield (①).
- b. Push the rear UV shield to the front of the machine, and then place this shield on the left and right stoppers (②).

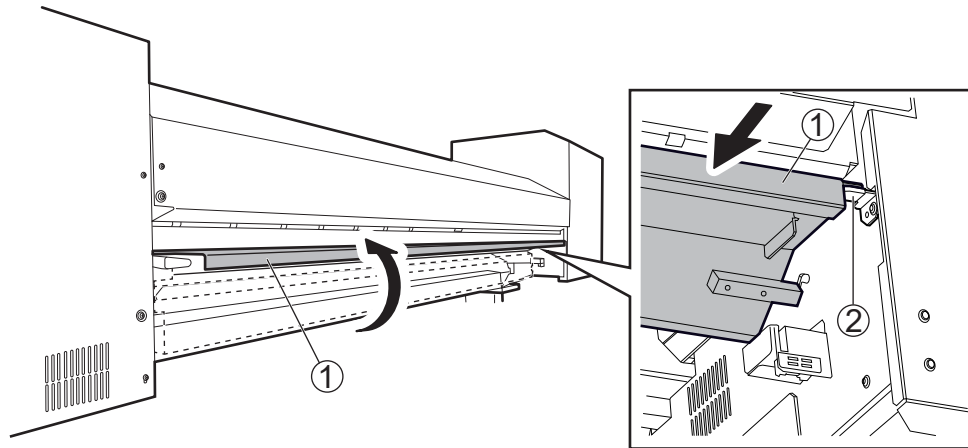

6. Release the locking mechanisms of the media holders, and then draw them to the left and right ends respectively.

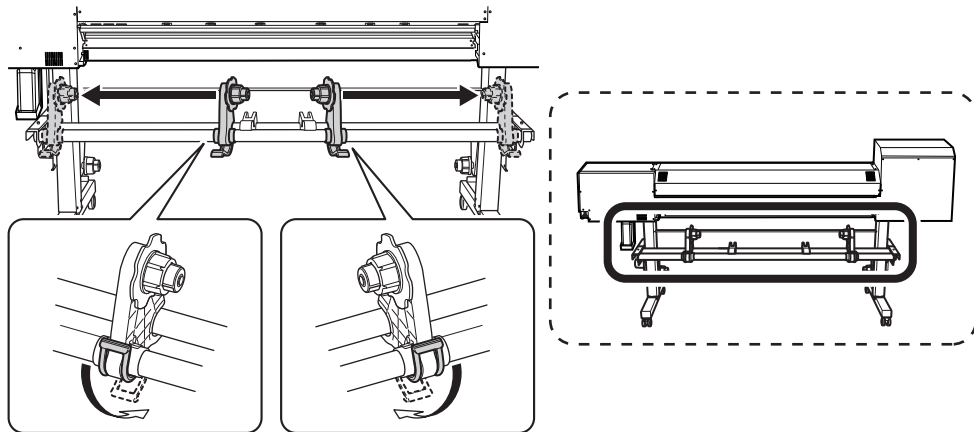

7. Place the media on the machine.

IMPORTANT

Do not leave media on the media stays or the pipes for a long period of time. The media may become deformed. Exercise caution.

- **Media with an outer diameter of 220 mm (8.66 in.) or less**

Place the media stays at positions that are $1/4$ the length of the media from each end of the media, and then load the media.

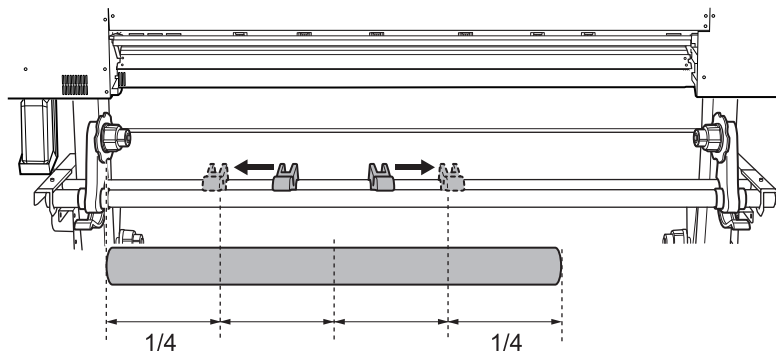

- **Media with an outer diameter exceeding 220 mm (8.67 in.)**
 - a. Rotate the media stays to draw them to the media holders.

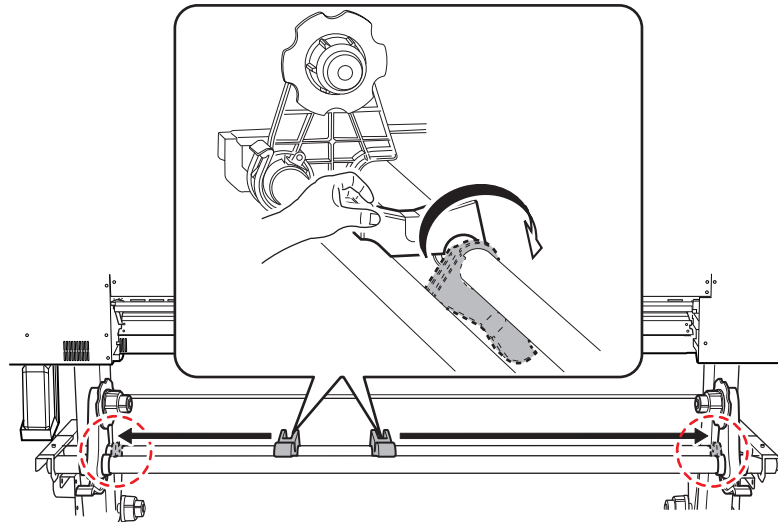

b. Place the media directly between the two pipes.

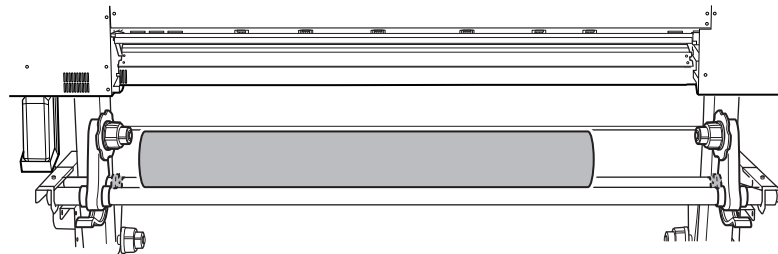

8. Fit the paper tube (core) of the media onto the end cap of the left media holder.

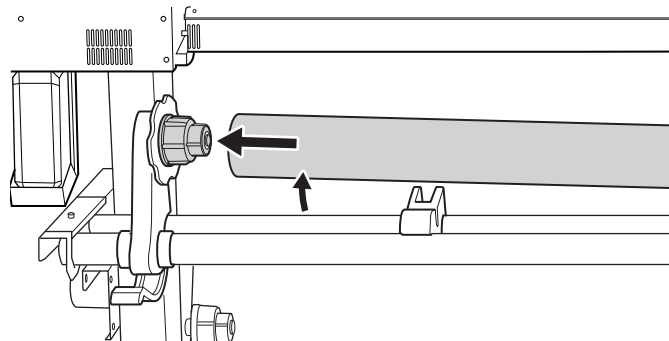

9. Move the right media holder to fit its end cap onto the paper tube (core) of the media.
Fit the paper tube onto the media holders securely to prevent the media from moving easily.

IMPORTANT

Do not secure the media holders in place just yet.

In the following procedure, you will adjust the positions of the media holders before securing them in place. Do not secure them in place just yet.

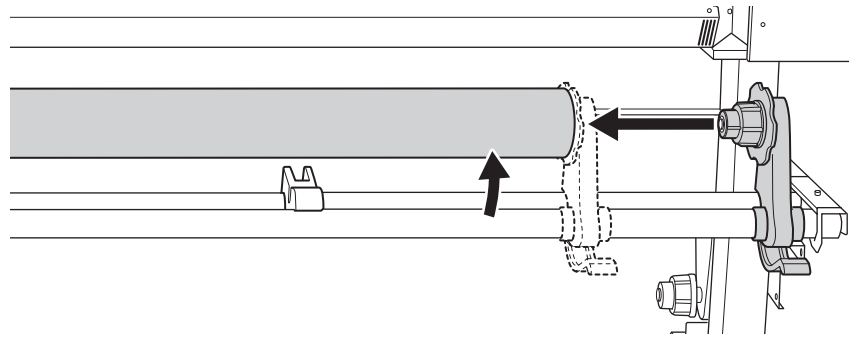

The next operation to perform varies depending on the media type and the Preferences. Proceed as shown below.

- For general media: [2. A: Determine the positions of the media.](#)(P. 36)
- For transparent media or if **[Preferences]>[Media Edge Detection]** is set to **[Disable]**: [2. B: Determine the positions of the media \(\[Media Edge Detection\]: \[Disable\]\).](#)(P. 42)

2. A: Determine the positions of the media.

This section describes how to use the suction fan to prevent media skewing. When using transparent media, whose edges cannot be detected, and when [Preferences]>[Media Edge Detection] is set to [Disable], the suction fan does not activate, so media cannot be loaded with this procedure. In these cases, refer to 2. B: Determine the positions of the media ([Media Edge Detection]: [Disable]).(P. 42).

By default, [Skewing Correction Support at Setup] is set to [Enable].

Procedure

1. Determine the left and right positions of the media with the grit patterns used as the reference.

Note the following points when determining the positions.

- Hold the media holders from the outside and move them.
- Ensure that the left edge of the media is positioned so that it is within the range of the grit pattern of the left edge.
- Ensure that the right edge of the media is positioned so that it is within the range of one of the grit patterns.

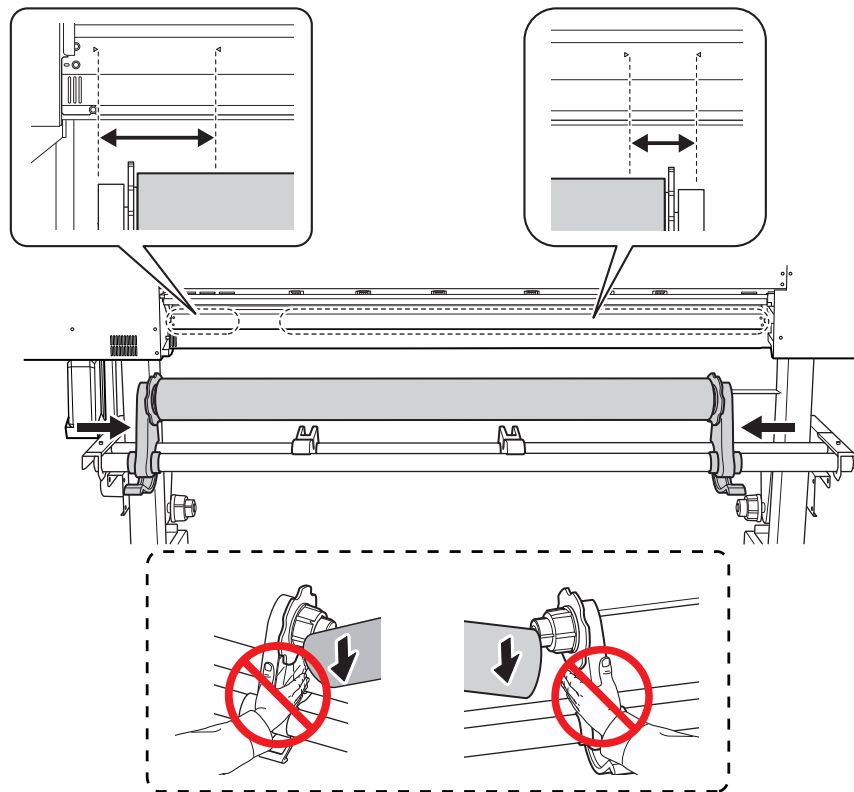

⚠ CAUTION

Do not hold places other than those instructed. Do not move the media by holding it directly.

Otherwise the media may fall off the media holder and cause injury.

IMPORTANT

Firmly decide the left and right side positions of the media at this point.

After this procedure is completed, if the left and right side positions do not fit the proper positions when securing the media with pinch rollers, you will have to go back to this step to redo this procedure. If you just

hold the media to readjust its position forcibly, the media will be skewed during printing, which will have an adverse effect on the printing results.

2. Secure the media holders.

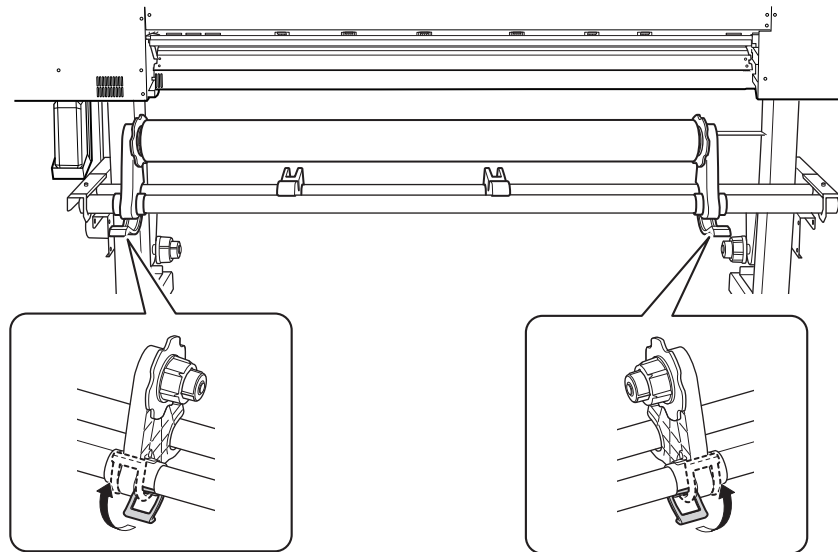

3. Use the following procedure to load the media.

Doing so will prevent media skewing.

- (1) Pass the leading edge of the media between the pinch rollers (A) and the grit rollers (B).

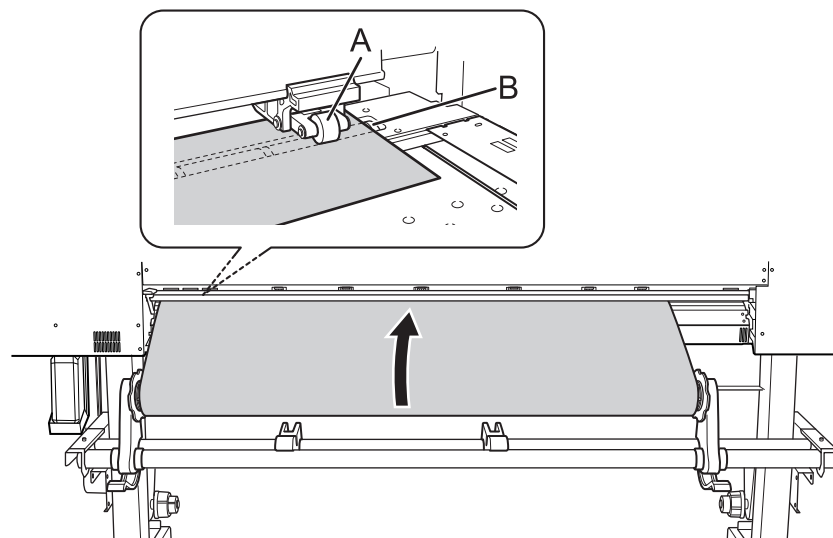

- (2) Feed the media until you hear a beep, and then additionally feed approximately 20 cm (7.87 in.) of the media.

You will hear a beep. Approximately 5 seconds later, you will hear two beeps, and then the suction fan will activate. While this fan is operating, the position of the media will be maintained even if you remove your hands from it.

- (3) Hold the media holder flange, turning it in the take-up direction to eliminate the slack in the media.

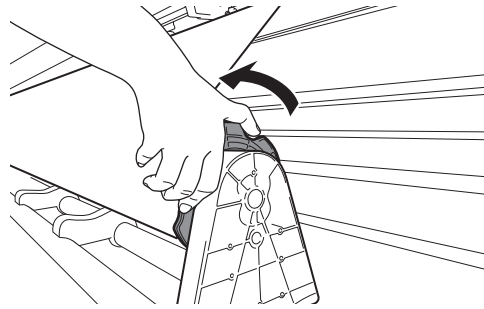

(4) Once the media is taut, additionally take up approximately 10 cm (3.94 in.) of media.

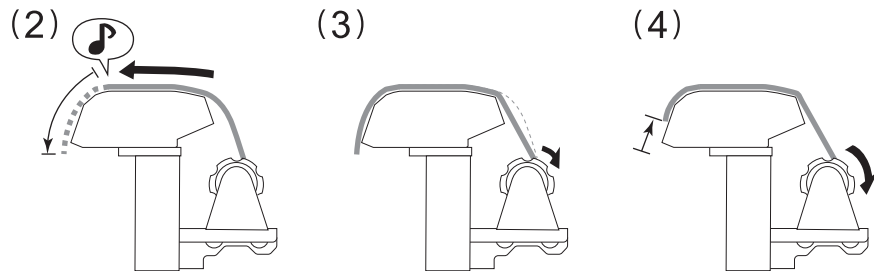

MEMO

If you take up too much media, you will hear two short beeps and the suction fan will stop. Take up the media, and then redo the procedure from step (1).

4. Close the rear UV shield.

- a. Pull the rear UV shield (①) to the back of the machine, and then remove this shield from the left and right stoppers (②).
- b. Close the rear UV shield.

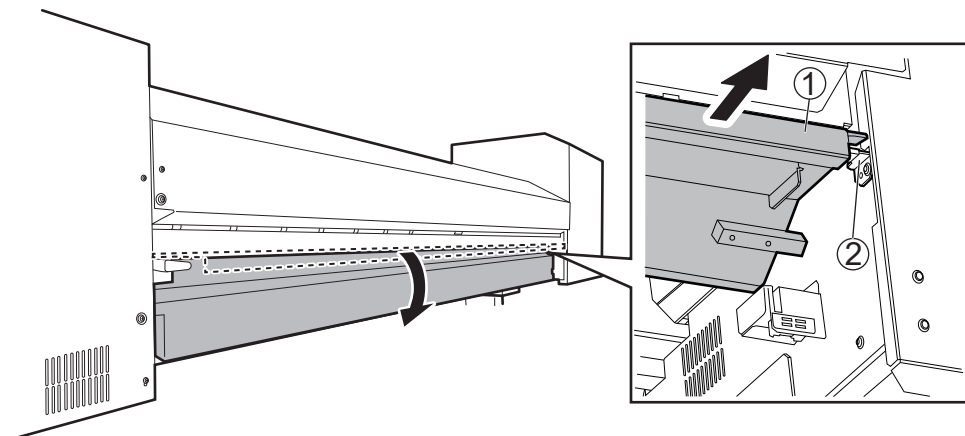

- 5. (Move to the front of the printer.) Make sure both edges of the media are above the grit rollers. Be sure to place the right edge of the media on the right-end grit roller.**

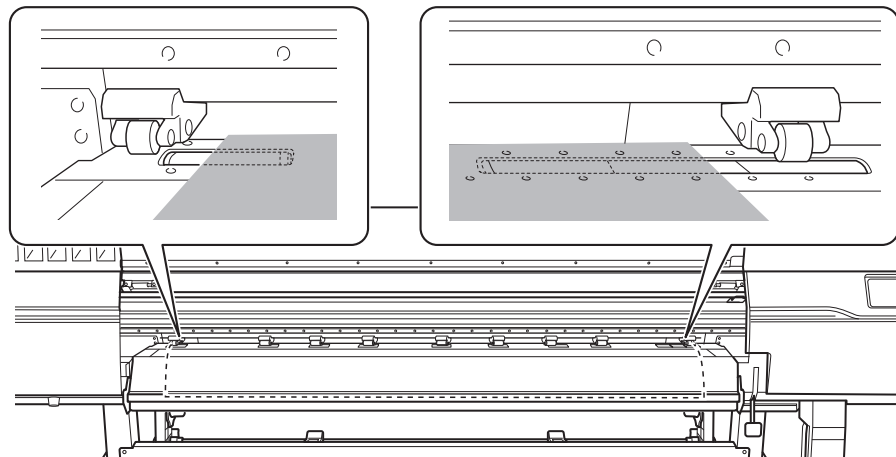

- 6. Move the left and right pinch rollers, placing them on both edges of the media.**
Position them approximately 10 mm (0.39 in.) from each edge of the media.

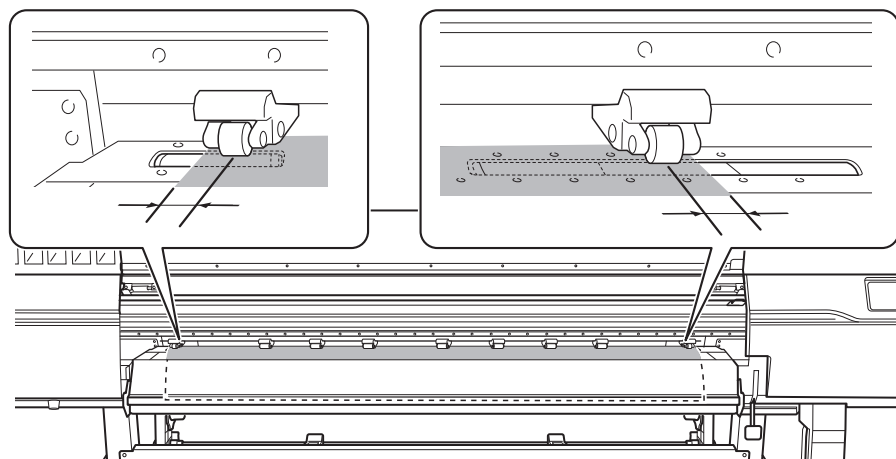

IMPORTANT

- Be sure to use the left and right pinch rollers. The force with which the media is pinched varies between the middle pinch rollers and the left and right pinch rollers. Using the middle pinch rollers to pinch the media edges will lead to unstable media feeding.
- If you want to readjust the media position, return to the back of the printer, release the media holders, and then redo the procedure from step 1. If you just stand at the front of the printer and hold the media to readjust its position forcibly, the media will be skewed during printing or will come loose, which will affect the printing quality.

MEMO

To smoothly move the pinch rollers, push down close to the rail.

- 7. Move the middle pinch rollers (B) over all the remaining grit rollers (A) covered by the media.**
There are grit patterns (C) wherever there are grit rollers.

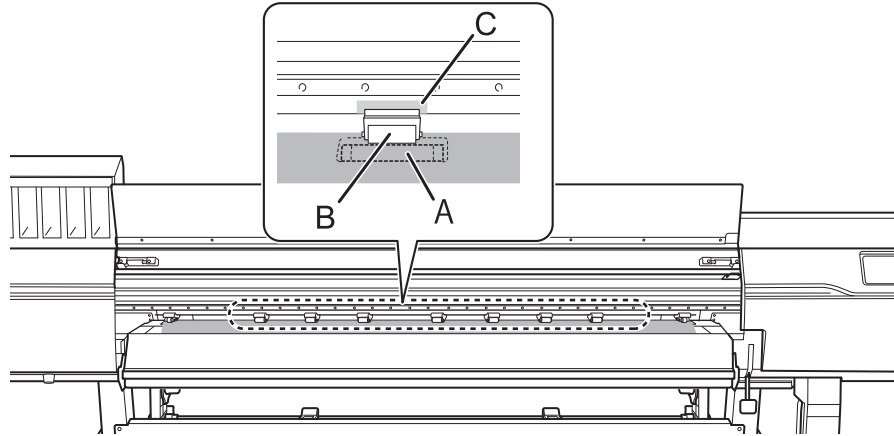

IMPORTANT

- Place the middle pinch rollers over all the grit patterns within the media width. If you have forgotten to place the middle pinch rollers, the media will be skewed during printing or will come loose, which will have an effect on the printing quality.
- The middle pinch roller will not lower onto the three grit rollers from the right end. Place the middle pinch roller on a grit roller other than these three.

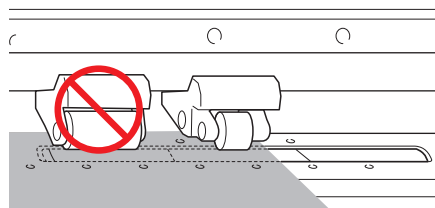

- There may be extra middle pinch rollers depending on the width of the media being used. Move the extra middle pinch rollers to positions where no grit patterns are present. Where no grit patterns are present, the middle pinch rollers will not come down.

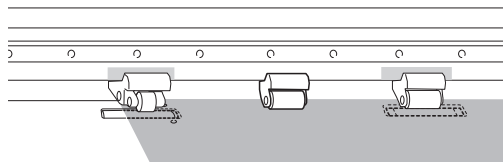

8. Lower the loading lever (front).

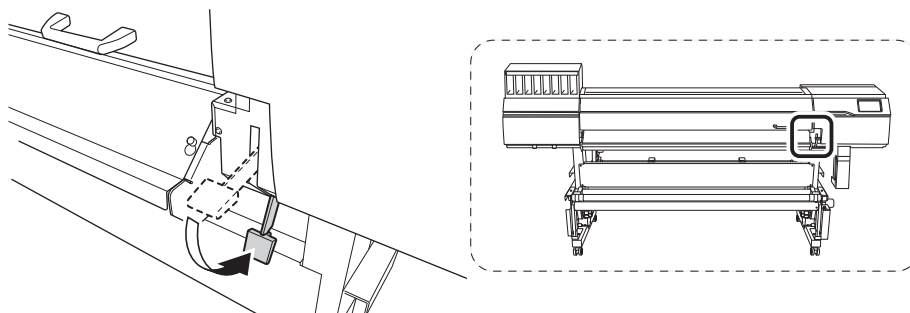

IMPORTANT

If you want to readjust the media position, return to the back of the printer, release the media holders, and then redo the procedure from step 1. If you just stand at the front of the printer and hold the media to readjust its position forcibly, the media will be skewed during printing or will come loose, which will affect the printing quality.

9. Line up the edges of the media with the centers of the holes of the left and right media clamps.

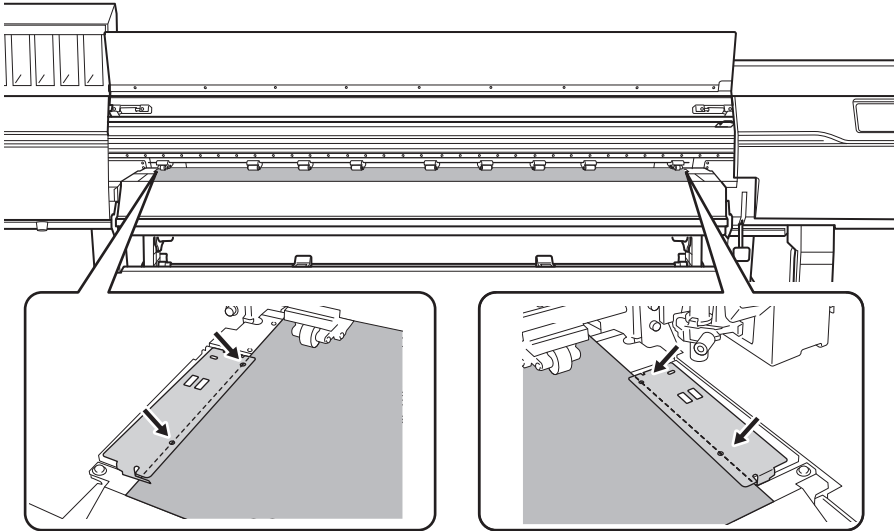

10. Close the front cover.

2. B: Determine the positions of the media ([Media Edge Detection]: [Disable]).

This section describes how to determine the positions of the media without using the suction fan. Refer to this information when using transparent media, whose edges cannot be detected, and when [Preferences]>[Media Edge Detection] is set to [Disable].

Procedure

1. Determine the left and right positions of the media with the grit patterns used as the reference.

Note the following points when determining the positions.

- Hold the media holders from the outside and move them.
- Ensure that the left edge of the media is positioned so that it is within the range of the grit pattern of the left edge.
- Ensure that the right edge of the media is positioned so that it is within the range of one of the grit patterns.

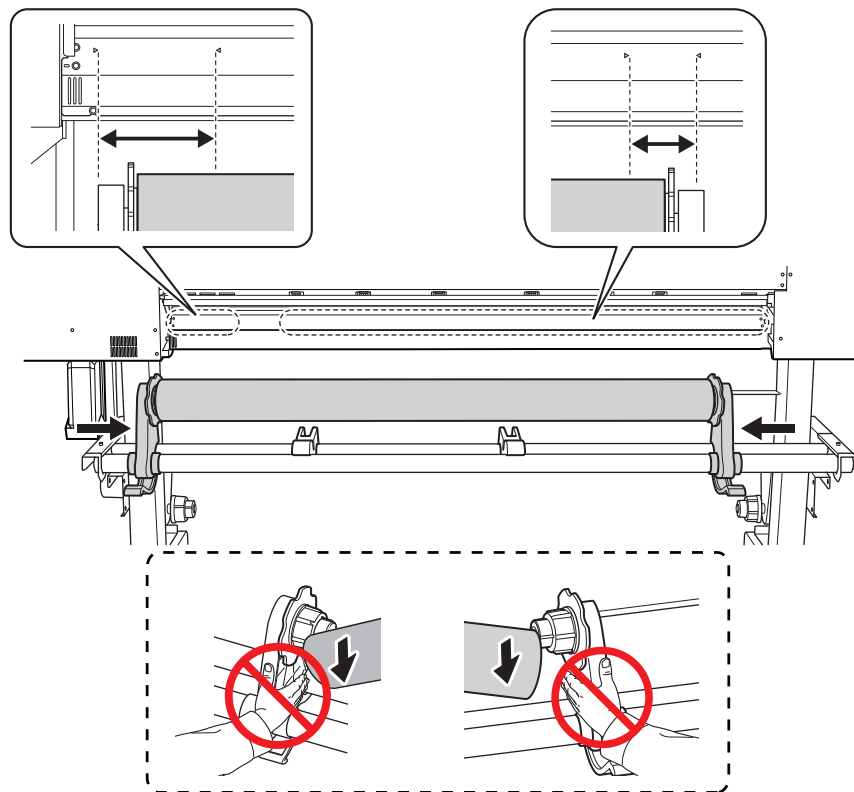

⚠ CAUTION

Do not hold places other than those instructed. Do not move the media by holding it directly.

Otherwise the media may fall off the media holder and cause injury.

IMPORTANT

Firmly decide the left and right side positions of the media at this point.

After this procedure is completed, if the left and right side positions do not fit the proper positions when securing the media with pinch rollers, you will have to go back to this step to redo this procedure. If you just hold the media to readjust its position forcibly, the media will be skewed during printing, which will have an adverse effect on the printing results.

2. Secure the media holders.

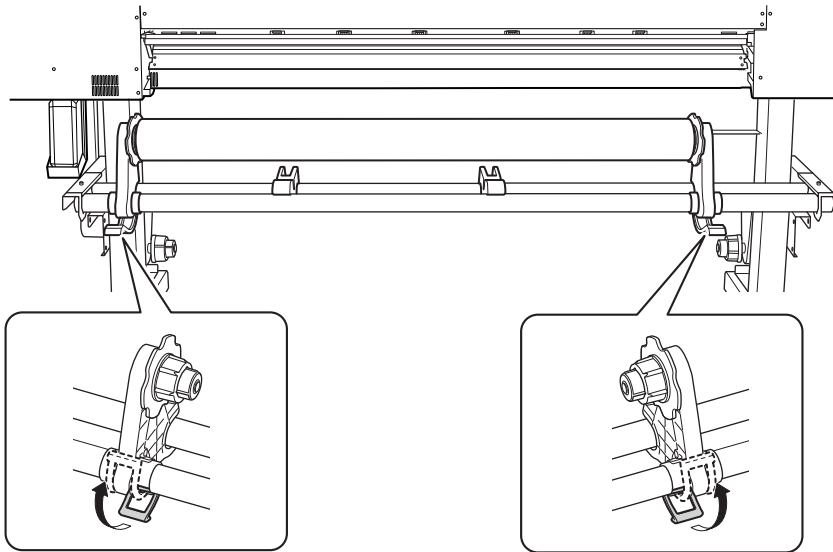

3. Pass the leading edge of the media between the pinch rollers (A) and the grit rollers (B).

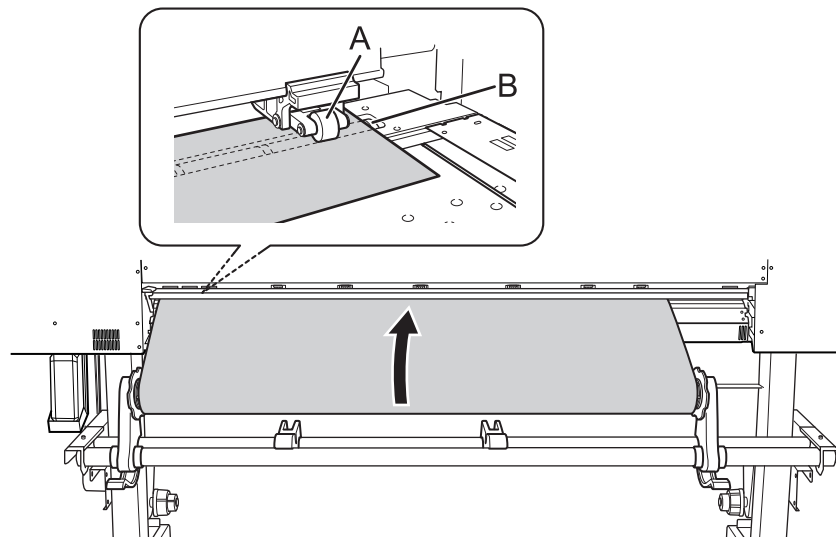

**4. Lower the loading lever (rear).
The media is held in place.**

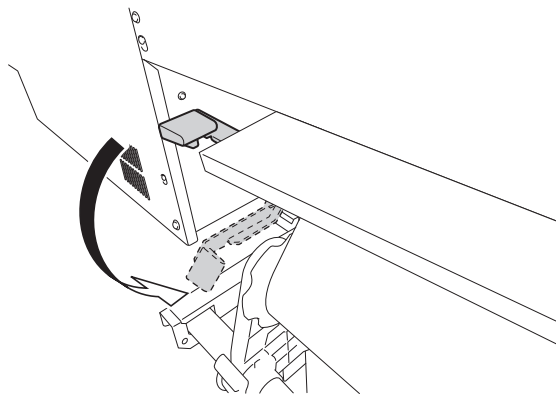

5. Close the rear UV shield.

- a. Pull the rear UV shield (①) to the back of the machine, and then remove this shield from the left and right stoppers (②).
- b. Close the rear UV shield.

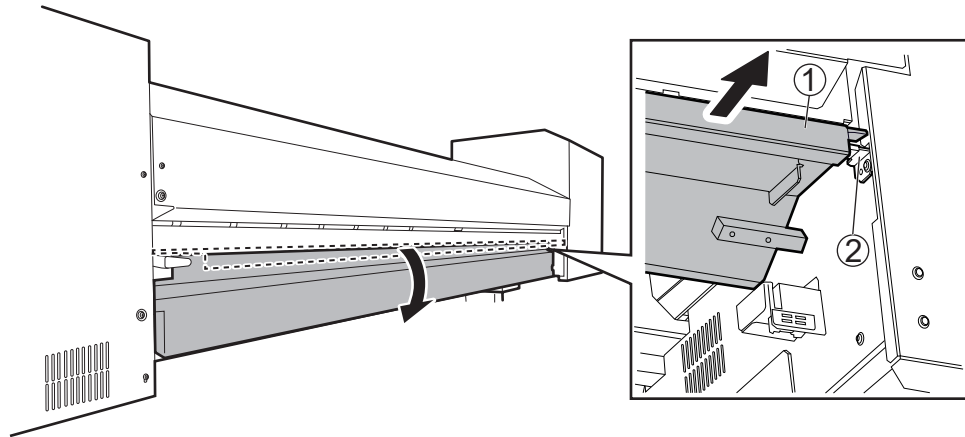

6. (Move to the front of the printer.) Gently hold down the media and raise the loading lever (front). The media is released.

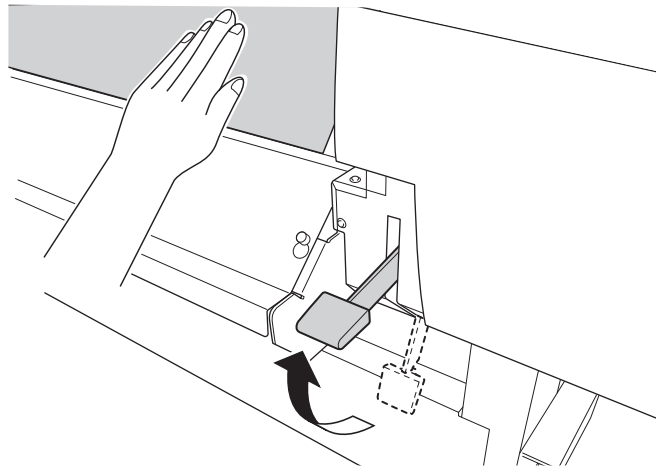

7. Pull out the media over the apron.

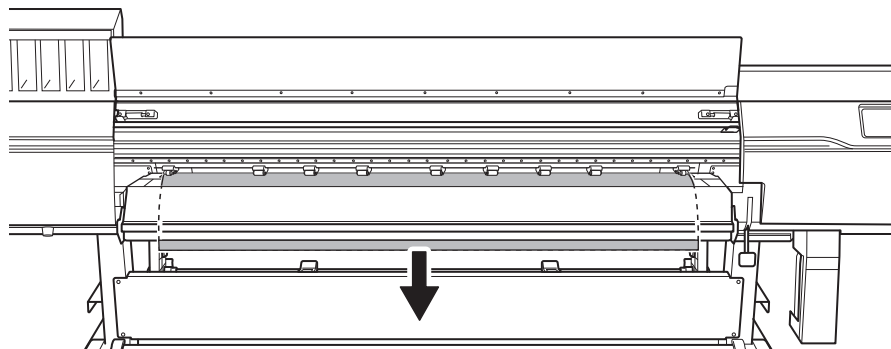

8. Make sure both edges of the media are above the grit rollers. Be sure to place the right edge of the media on the right-end grit roller.

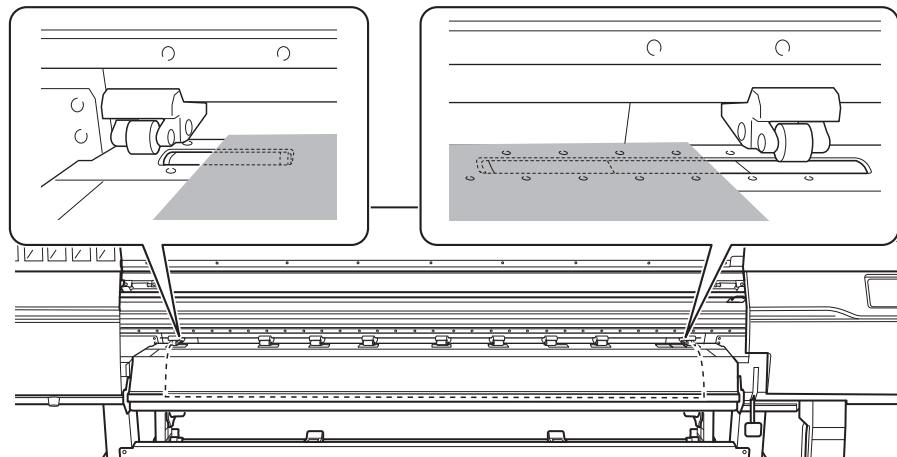

- 9. Move the left and right pinch rollers, placing them on both edges of the media.**
Position them approximately 10 mm (0.39 in.) from each edge of the media.

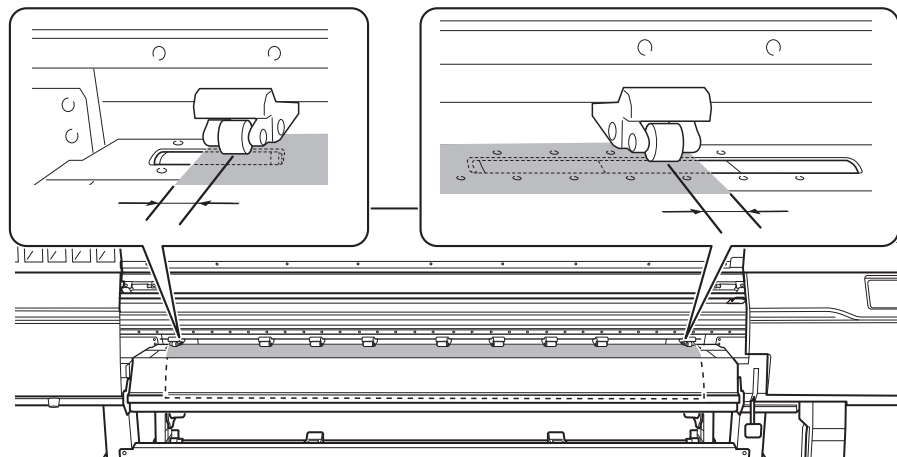

IMPORTANT

- Be sure to use the left and right pinch rollers. The force with which the media is pinched varies between the middle pinch rollers and the left and right pinch rollers. Using the middle pinch rollers to pinch the media edges will lead to unstable media feeding.
- If you want to readjust the media position, return to the back of the printer, release the media holders, and then redo the procedure from step 1. If you just stand at the front of the printer and hold the media to readjust its position forcibly, the media will be skewed during printing or will come loose, which will affect the printing quality.

MEMO

To smoothly move the pinch rollers, push down close to the rail.

- 10. Move the middle pinch rollers (B) over all the remaining grit rollers (A) covered by the media.**
There are grit patterns (C) wherever there are grit rollers.

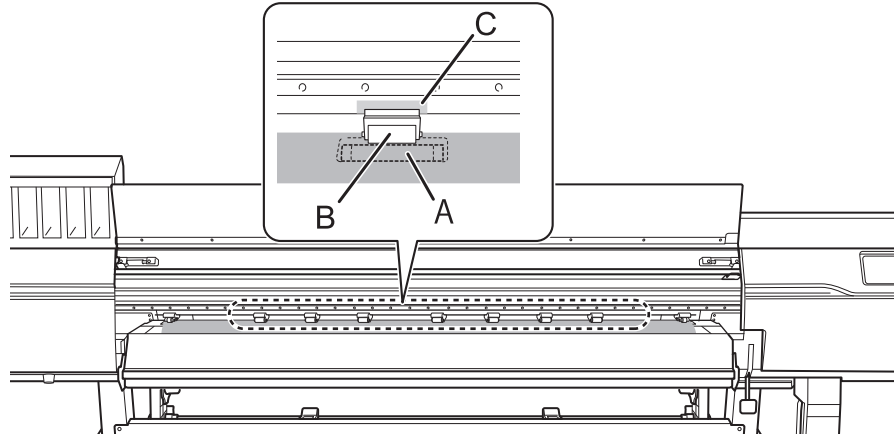

IMPORTANT

- Place the middle pinch rollers over all the grit patterns within the media width. If you have forgotten to place the middle pinch rollers, the media will be skewed during printing or will come loose, which will have an effect on the printing quality.
- The middle pinch roller will not lower onto the three grit rollers from the right end. Place the middle pinch roller on a grit roller other than these three.

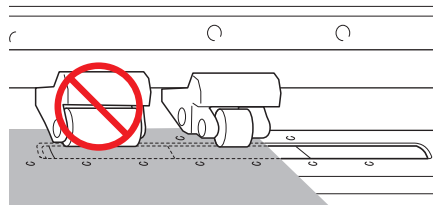

- There may be extra middle pinch rollers depending on the width of the media being used. Move the extra middle pinch rollers to positions where no grit patterns are present. Where no grit patterns are present, the middle pinch rollers will not come down.

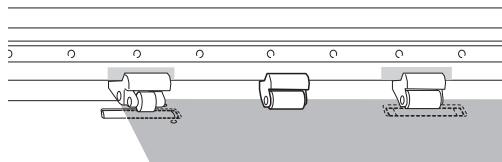

11. Hold the media at the center and pull it out, being sure to keep it straight and all areas of the media to be taut.

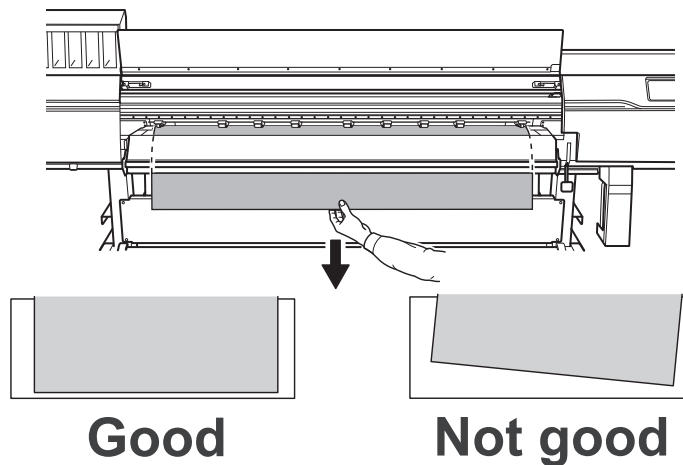

12. Lower the loading lever (front).

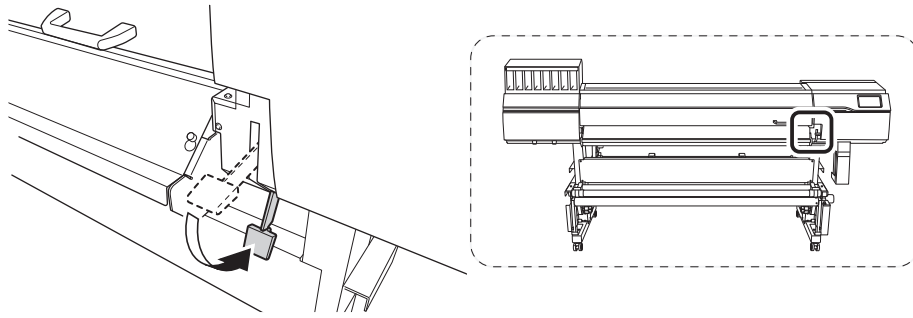

13. Line up the edges of the media with the centers of the holes of the left and right media clamps.

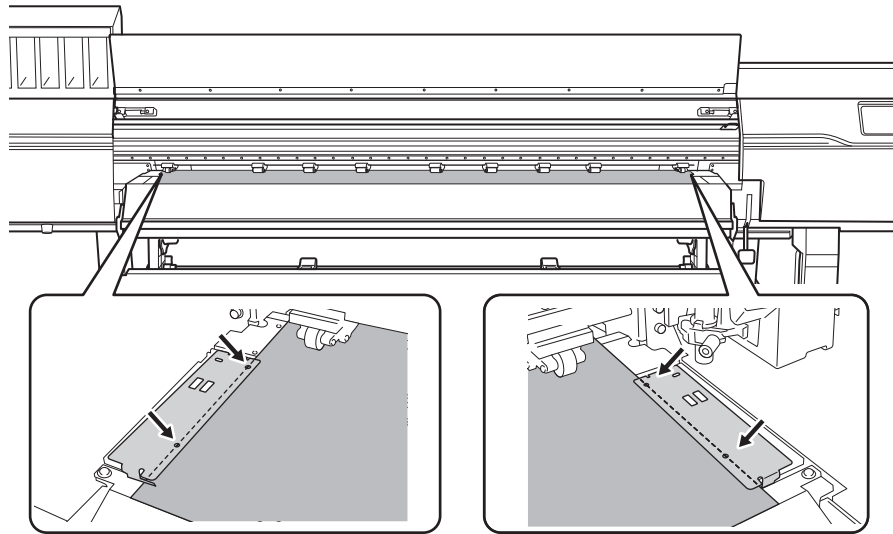

14. Close the front cover.

3. Register the media.

Procedure

1. Tap  [Setup].

2. Select [New].

3. Tap [Next].

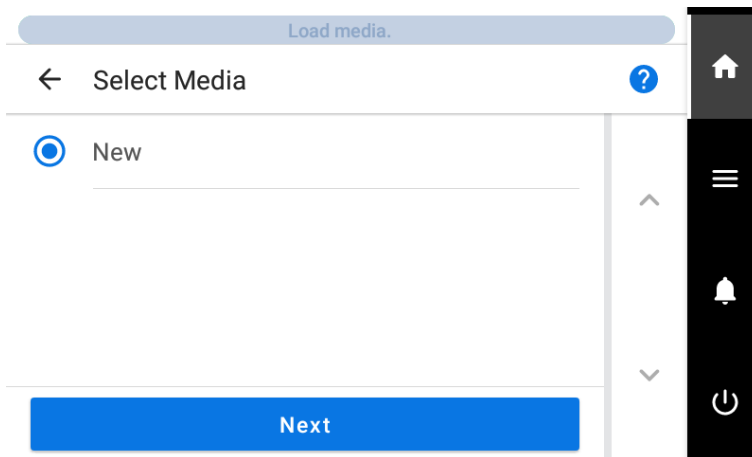

4. Enter a new media name and tap [OK].

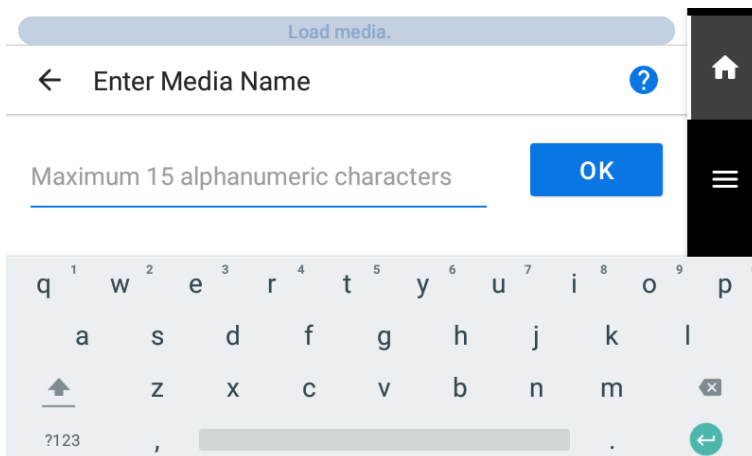

5. Tap [Next].

6. The [Setup Method] screen appears. Select whether to use the take-up unit.

7. Tap [Start Setup].

The cutting carriage moves and detects the width of the media and the positions of the media clamps. This operation is called initialization.

8. When [The media could not be detected automatically. Manually set the printing area.] appears, use the following procedure to configure the settings.



MEMO

This message may appear when media with high reflectance is set up.

(1) Tap [OK].

(2) Tap [Change].

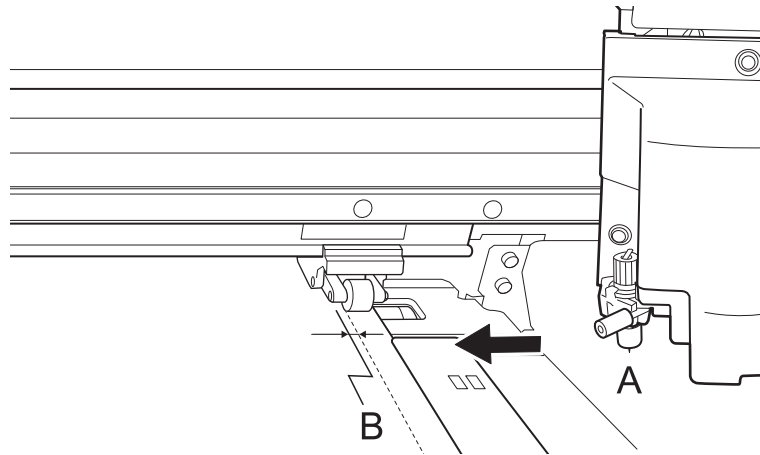

The [Set the right edge of the printing area within the area specified by the pinch rollers.] screen appears.

(3) Hold down  or  to move the center of the blade (A) approximately 2 mm (0.08 in.) to the inside (B) from the left edge of the right pinch roller.



(4) Tap [OK].

The [Set the left edge of the printing area within the area specified by the pinch rollers.] screen appears.

(5) Hold down  or  to move the center of the blade (A) approximately 2 mm (0.08 in.) to the inside (B) from the right edge of the left pinch roller.

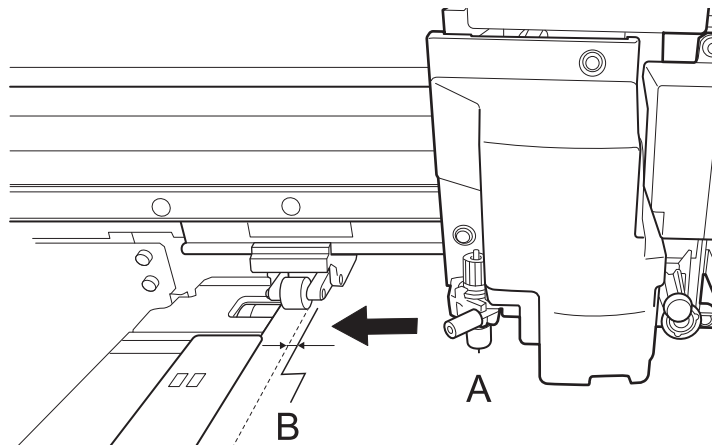

(6) Tap [OK].

The set left and right positions are applied to the [Printing Area (Width)].

(7) Tap [OK].

4. Load the media in the take-up unit.

If you will not use the take-up unit, proceed to [5. Configure settings to match the media.](#) (P. 54).

Procedure

1. Lower the dancer roller toward the rear.

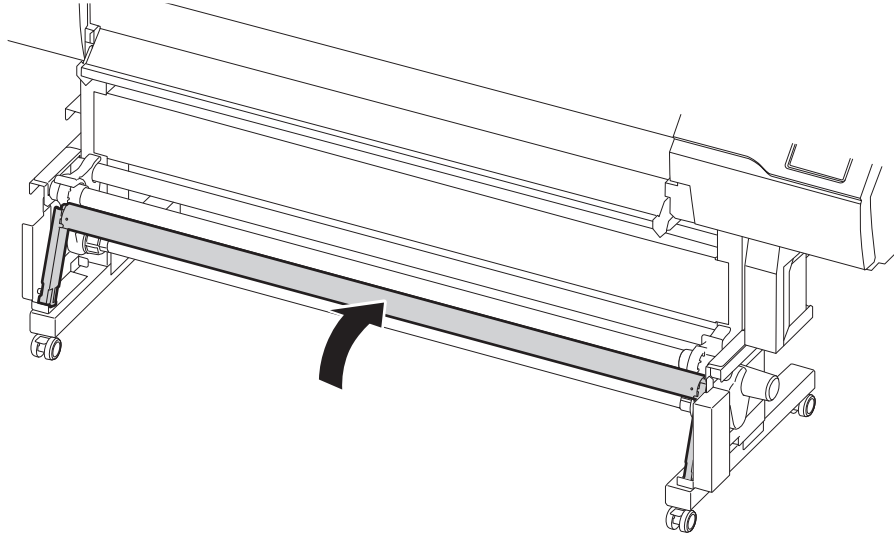

2. Follow the procedure below to load a paper tube on the media holders of the take-up unit.
Prepare a paper tube wider than the media that has been set up.

IMPORTANT

Paper tubes are consumable items.

Watch the condition of the paper tube and replace at an appropriate time so that the media can be taken up in good working order.

- (1) Release the media holders to enable their movement.

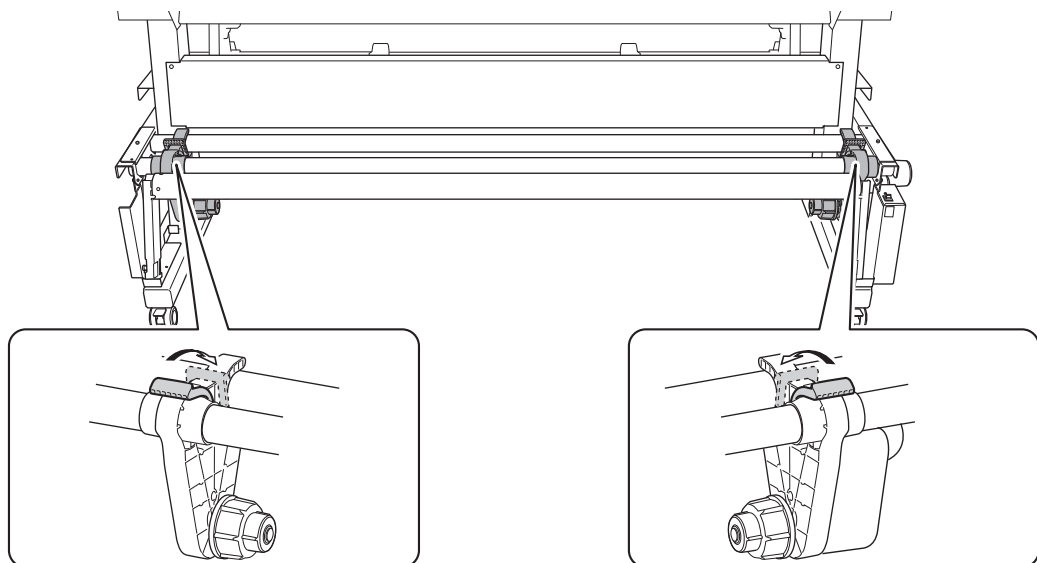

- (2) Fit the paper tube onto the right end cap.
Fit the paper tube securely right to the end of the end cap.
- (3) Push the left media holder into the paper tube.

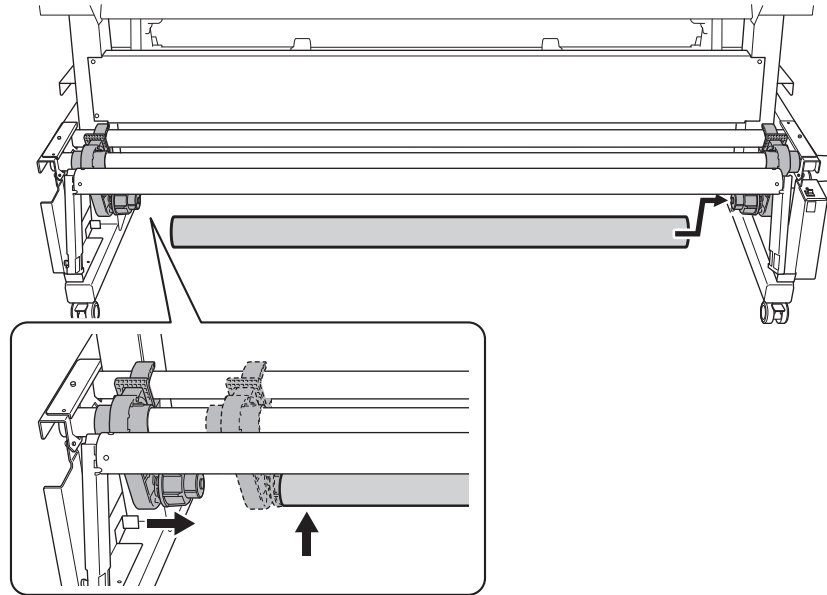

3. Hold down  on the operation panel to feed out the media until the tip of the media reaches the paper tube.

Media is fed out 10 mm (0.39 in.) each time you hold down this button. Holding down the button lets you feed out paper continuously.

Good

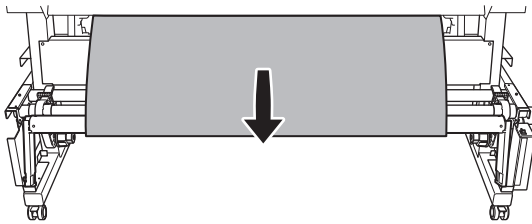

Not Good

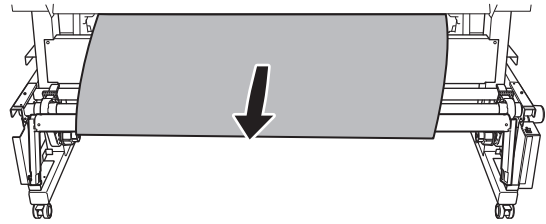

MEMO

Feed out the media until it can wrap around at least 1/4 of the paper tube.

When using the FORWARD setting	When using the BACKWARD setting

4. Follow the procedure below to adjust the positions of the media holders.

(1) Move both media holders so that it is possible to see the paper tube from the right edge of the media.

Hold the media holders from the outside and move them.

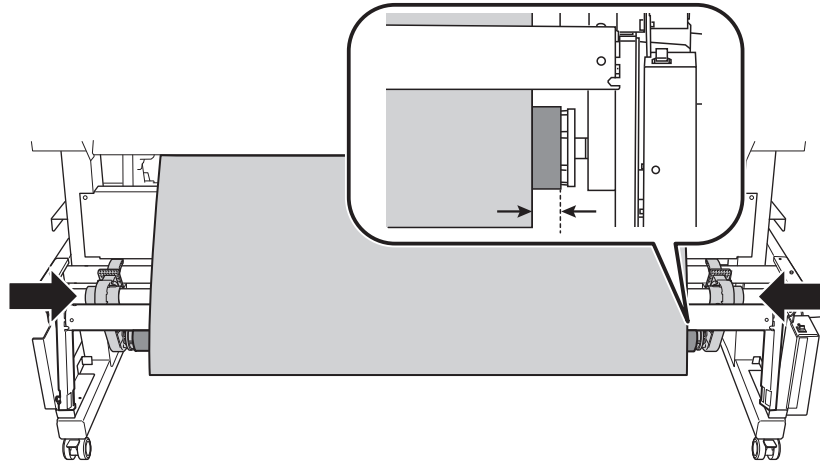

(2) Secure the left and right media holders.

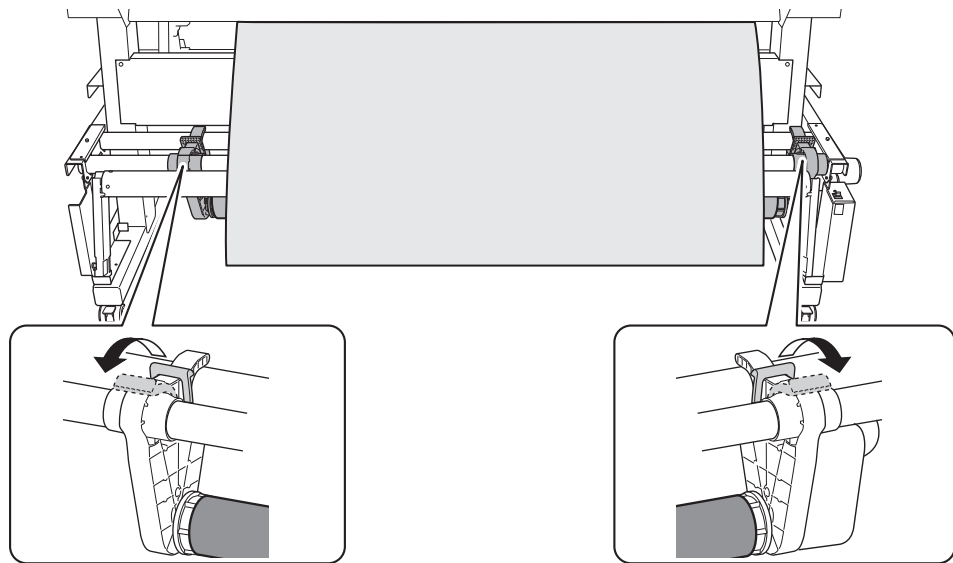

5. Follow the procedure below to secure the media on the paper tube.

Secure the media in the [Take-up Direction] set in step 2 of 1. [Install the media on the media holders.](#)(P. 31).

- (1) While pulling the media so that it does not sag, secure the center of the media on the paper tube with adhesive tape.
- (2) While pulling the media from the center toward the outer edges, secure the left and right edges of the media on the paper tube with adhesive tape.

- When using the FORWARD setting

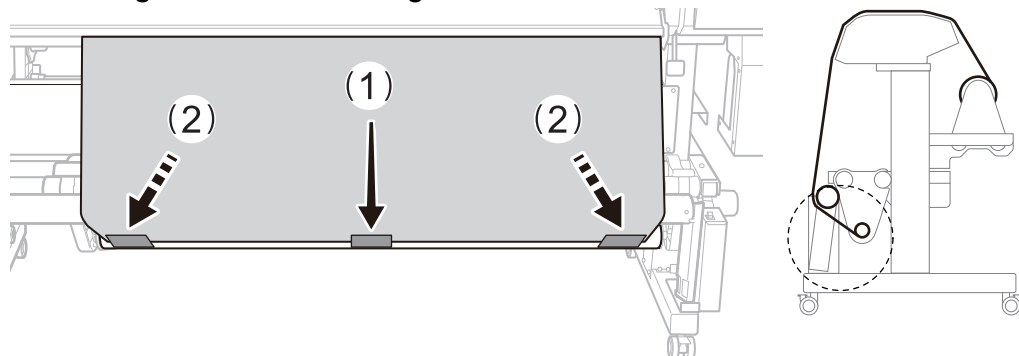

- When using the BACKWARD setting

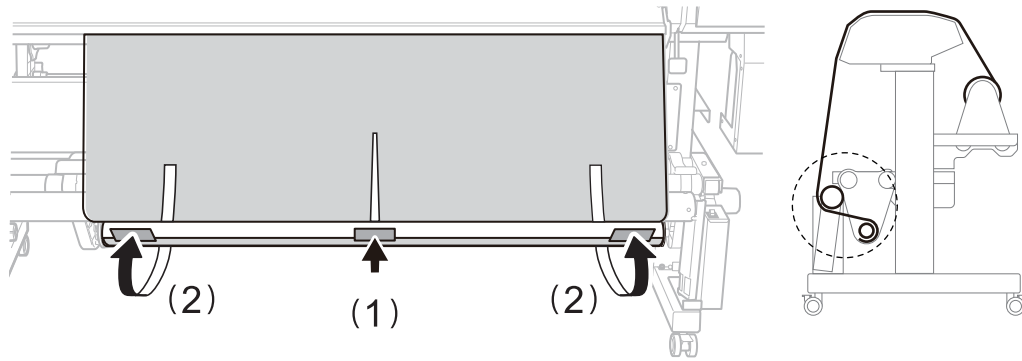

6. Tap [OK].
A small amount of the media is fed out.
7. Lower the dancer roller toward the front.

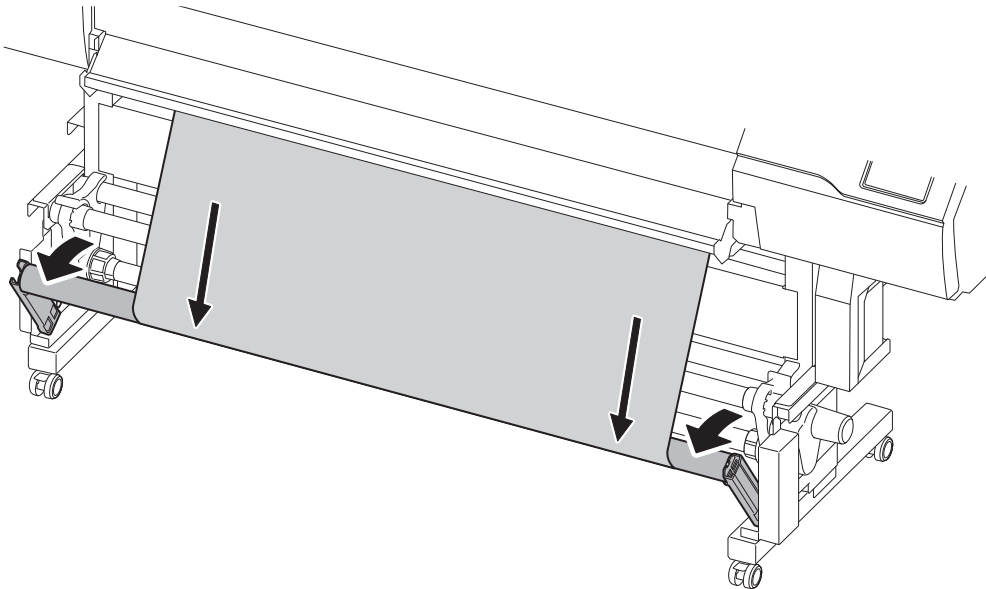

8. Tap [OK].

5. Configure settings to match the media.

To ensure the optimal output according to the media size and type, set the minimal amount of items. All items set here can be set individually as well.

Procedure

1. On the [Select Media Output Type] screen, select the output type and tap [Next].
 - [Print Only/Print & Cut]
Proceed to step 2.
 - [Cut Only]
Switch to the [Multi Sensor Adjustment] screen. When automatic adjustment is finished, tap [OK]. This completes the settings for [Cut Only].
If the adjustment failed, respond to the failure according to the information in [Correcting the Reading Sensor\(P. 206\)](#).
2. Use the [Print Head Height] screen to adjust the print head height.
 - If this is not necessary, tap [Next].
 - Follow the procedure below to make adjustments.
 - a. Tap [Change]
 - b. Open the front cover.
 - c. Move the height-adjustment lever to adjust the head height.
 - d. Close the front cover.
 - e. Tap [OK].
 - f. Tap [Next].
 For details on this work, refer to [Changing the Print Head Height\(P. 172\)](#).
3. On the [Nozzle Drop-out Test] screen, configure the [Printing Test] and [Output Start Location] settings.
 - If this is not necessary, tap [Next].
 - To perform a [Printing Test], tap [Printing Test]>[Execute]. For details on what to do after the printing test, refer to [Step 2: Normal Cleaning Method\(P. 134\)](#).
When the printing test finishes, tap [Next].
4. On the [Select Media Adjustment Method] screen, select the adjustment method.
Here, the media feed correction for reducing horizontal bands and the correction of the landing position of the ink will be adjusted.

MEMO

[Simple Correction (Auto)] is the recommended adjustment. You can determine the correction values with [Detailed Correction (Manual)].

- Follow the procedure below to make automatic adjustments.
 - a. Tap [Simple Correction (Auto)]>[Next].
 - b. Tap [Execute] on the [Batch Automatic Correction] screen.
On successful completion of automatic adjustment, the home screen appears. This completes the settings.
For more information, refer to [Automatically Making Required Adjustments\(P. 167\)](#).
- Follow the procedure below to make manual adjustments.

- a. Tap **[Detailed Correction (Manual)]**>**[Next]**.
- b. Tap **[Execute]** on the **[Multi Sensor Adjustment]** screen.
Adjust the reading sensor to the optimal condition. If the adjustment failed, respond to the failure according to the information in [Correcting the Reading Sensor\(P. 206\)](#).
- c. Tap **[Next]**.
- d. Perform a printing test on the **[Detailed Feed Correction (Manual)]** screen.
Set the correction value from the printing test result. For more information, refer to [Manual Adjustment: Reducing Horizontal Bands \(Feed Correction\)\(P. 168\)](#).
- e. Tap **[Save and Proceed]**.
- f. Perform a printing test on the **[Detailed Media Gap Adjustment (Manual)]** screen.
Set the correction values from the printing test result. For more information, refer to [Manual Adjustment: Adjusting the Misalignment of the Ink Landing Position \(Media Gap Adjustment\)\(P. 170\)](#).
- g. Tap **[Save and Exit]**.

IMPORTANT

When printing and cutting or just cutting, rewind the media from the take-up device to slacken the media. If sufficient media is not wound on the paper tube immediately after setup, this operation may not be performed well, lowering the cutting quality and preventing continued take-up. When performing cutting immediately after attaching the media to the paper tube, first feed enough media to carry out take-up a few times and set the base point.

This completes the setup of the media.

Setup of Sheet Media

Load the sheet media on the printer. When the loading is finished, [Output possible.] is displayed as the status. This work is referred to as "Setup of Media."

1. A: Determine the positions of the media.

When using transparent media, whose edges cannot be detected, and when [Preferences]>[Media Edge Detection] is set to [Disable], the suction fan does not activate, so media cannot be loaded with this procedure. In these cases, refer to [1. B: Determining the Positions of Media \(If \[Media Edge Detection\]: \[Disable\]\)](#)(P. 61).

By default, [Skewing Correction Support at Setup] is set to [Enable].

Procedure

1. Tap  on the operation panel.
The sub power is switched on.
2. Open the front cover.
3. Move the media clamps to the outside of the grit rollers on the left and right edges respectively.

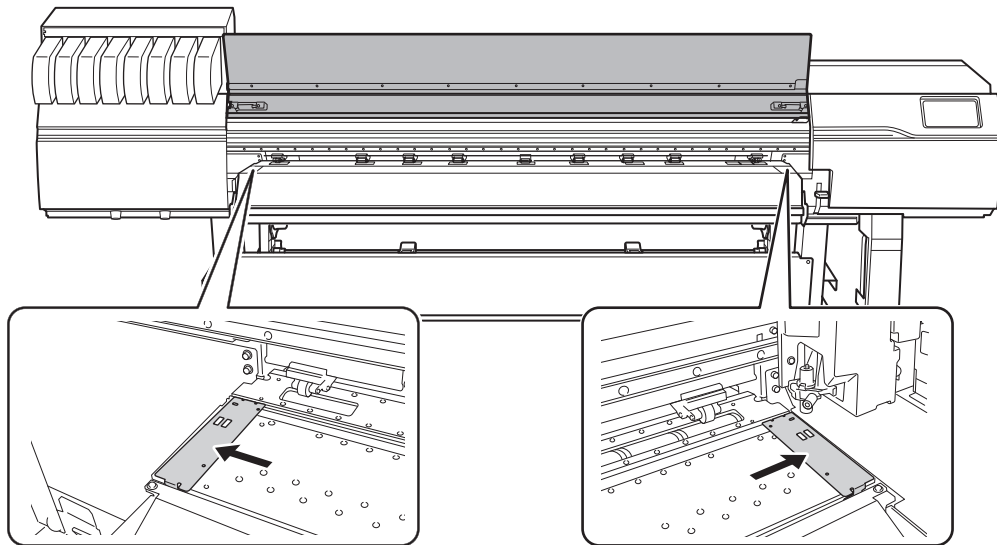

4. Release the locking mechanisms of the media holders, and then draw them to the left and right ends respectively.

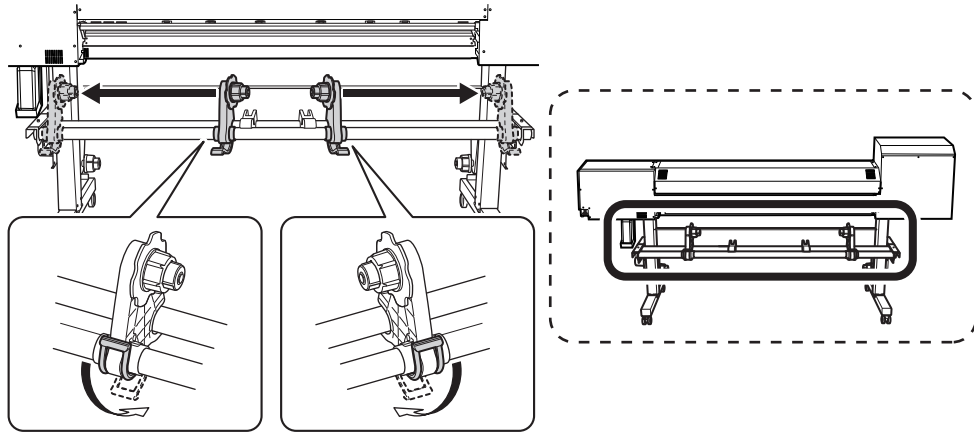

5. Move to the rear of the printer and open the rear UV shield.

- a. Open the rear UV shield (①).
- b. Push the rear UV shield to the front of the machine, and then place this shield on the left and right stoppers (②).

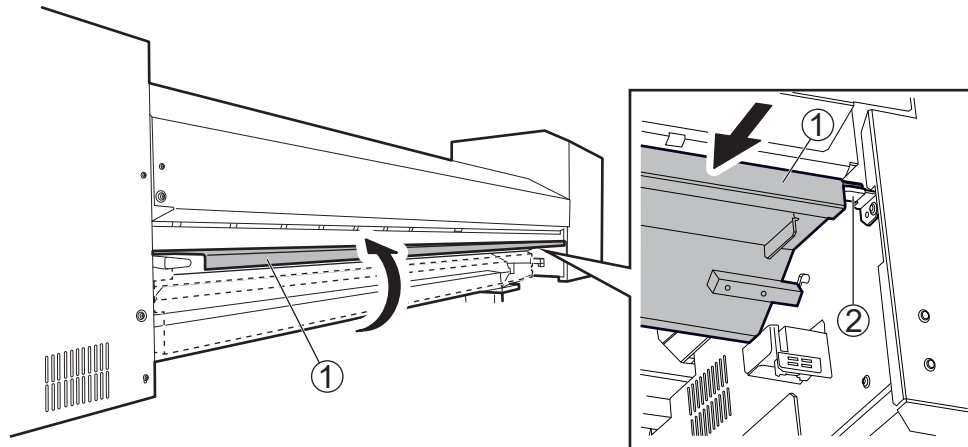

6. From the rear of the printer, pass the leading edge of the media between the pinch rollers (A) and the grit rollers (B).

You will hear a beep. Approximately 5 seconds later, you will hear two beeps, and then the suction fan will activate. While this fan is operating, the media will not move backward even if you remove your hands from it.

When loading the media from the front of the printer, feed the leading edge of the media (the side where printing will start) over the platen, and then pull the media to the front to activate the suction fan.

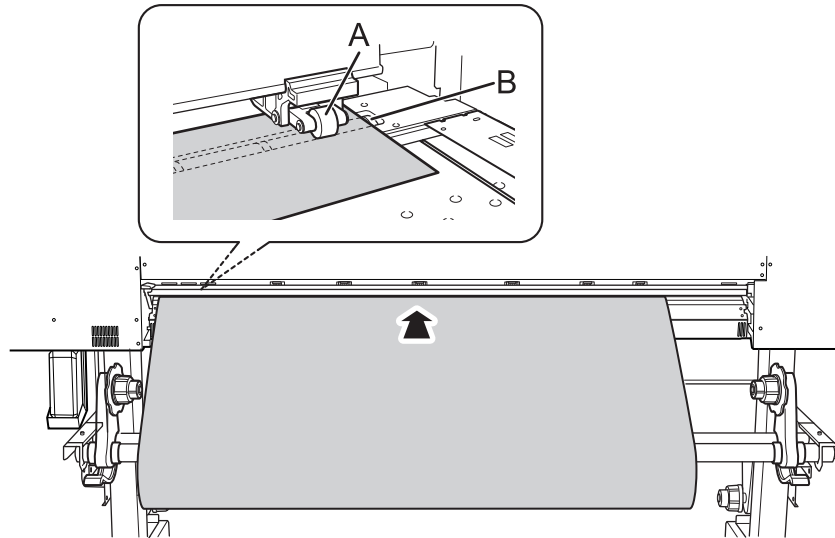

7. Close the rear UV shield.

- a. Pull the rear UV shield (①) to the back of the machine, and then remove this shield from the left and right stoppers (②).
- b. Close the rear UV shield.

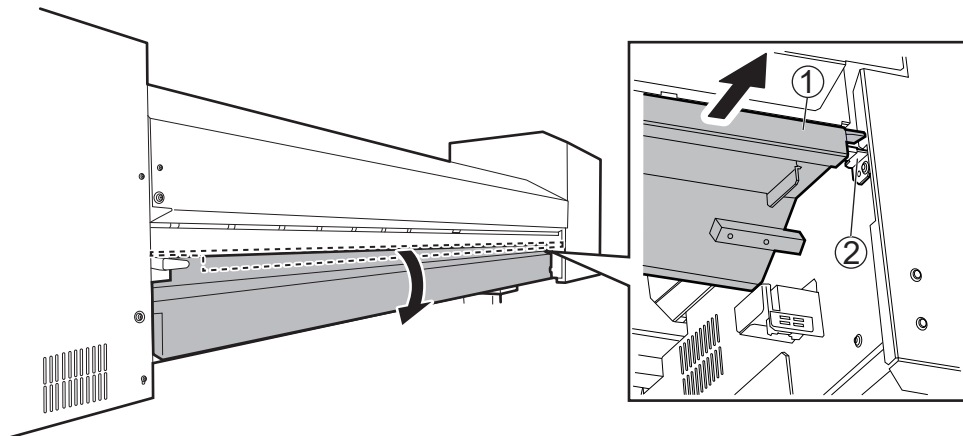

8. (Move to the front of the printer.) Make sure both edges of the media are above the grit rollers. Be sure to place the right edge of the media on the right-end grit roller.

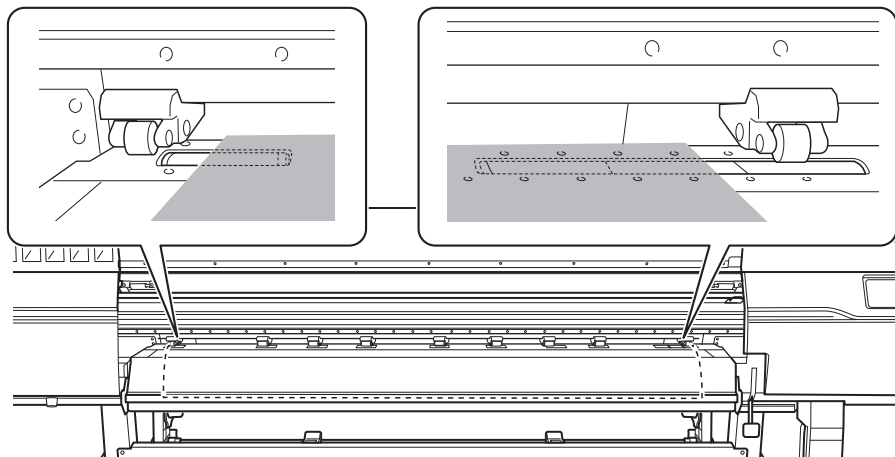

9. Move the left and right pinch rollers, placing them on both edges of the media.

Position them approximately 10 mm (0.39 in.) from each edge of the media.

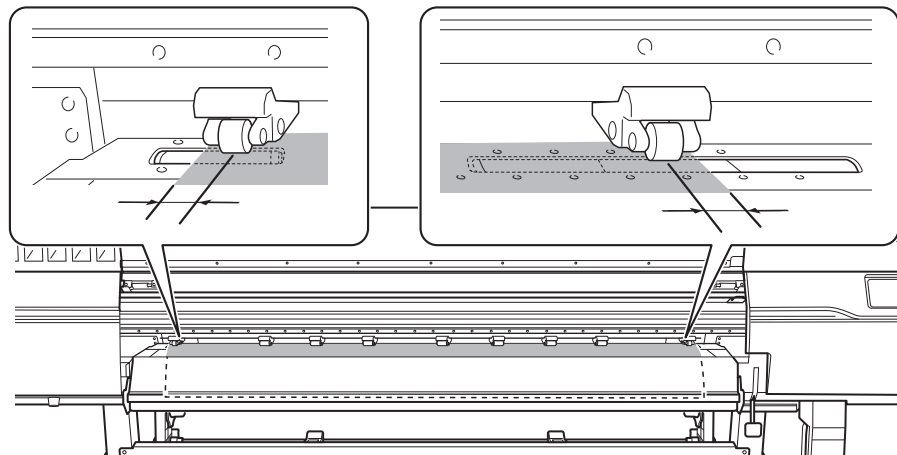

IMPORTANT

- Be sure to use the left and right pinch rollers. The force with which the media is pinched varies between the middle pinch rollers and the left and right pinch rollers. Using the middle pinch rollers to pinch the media edges will lead to unstable media feeding.
- If you want to readjust the media position before securing it in place, redo the procedure from step 5.

MEMO

To smoothly move the pinch rollers, push down close to the rail.

- 10.** Move the middle pinch rollers (B) over all the remaining grit rollers (A) covered by the media. There are grit patterns (C) wherever there are grit rollers.

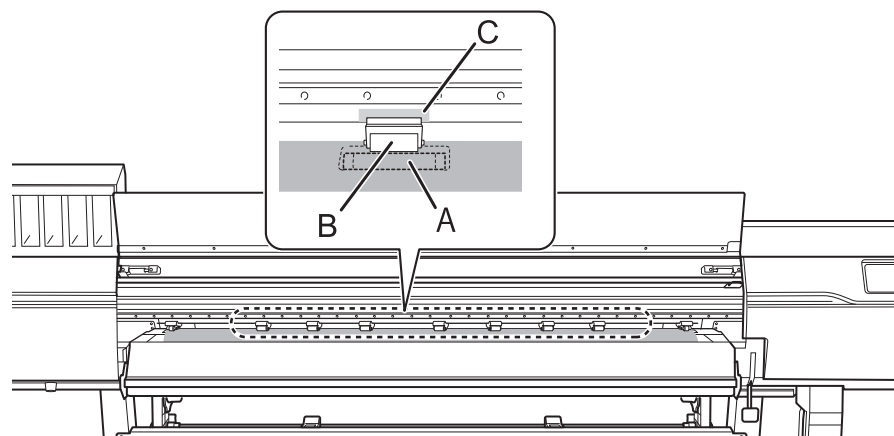

IMPORTANT

- Place the middle pinch rollers over all the grit patterns within the media width. If you have forgotten to place the middle pinch rollers, the media will be skewed during printing or will come loose, which will have an effect on the printing quality.
- The middle pinch roller will not lower onto the three grit rollers from the right end. Place the middle pinch roller on a grit roller other than these three.

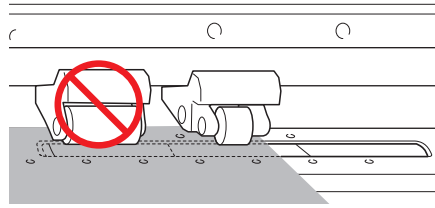

- There may be extra middle pinch rollers depending on the width of the media being used. Move the extra middle pinch rollers to positions where no grit patterns are present. Where no grit patterns are present, the middle pinch rollers will not come down.

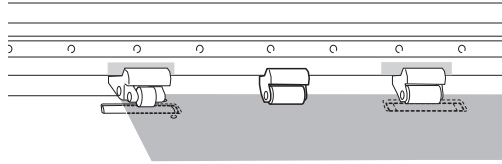

11. Lower the loading lever (front).

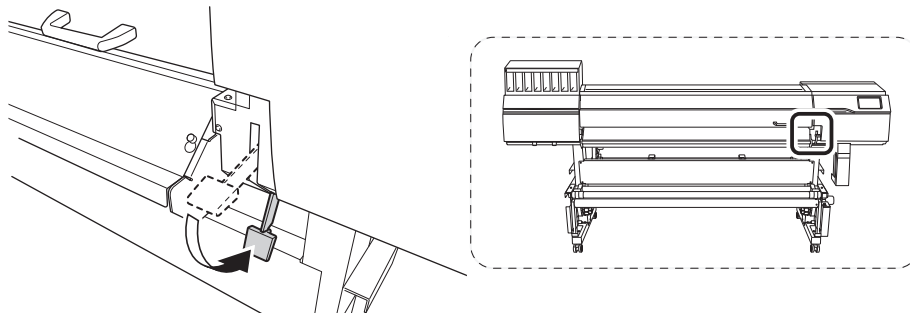

IMPORTANT

If you want to readjust the media position before securing it in place, redo the procedure from step 5.

12. Line up the edges of the media with the centers of the holes of the left and right media clamps.

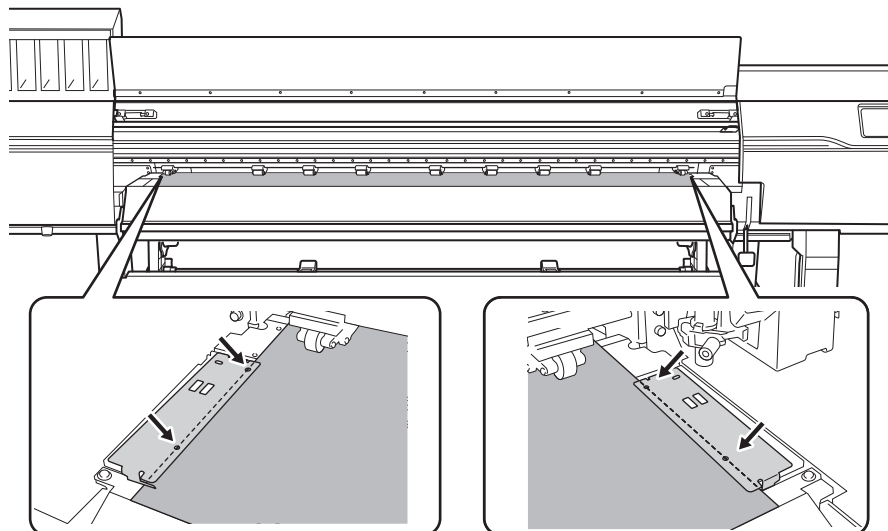

13. Close the front cover.

1. B: Determining the Positions of Media (If [Media Edge Detection]: [Disable])

Use the following procedure to determine the positions of the media when using transparent media, whose edges cannot be detected, and when [Preferences]>[Media Edge Detection] is set to [Disable].

Procedure

1. Tap  on the operation panel.
The sub power is switched on.

2. Open the front cover.

3. Move the media clamps to the outside of the grit rollers on the left and right edges respectively.

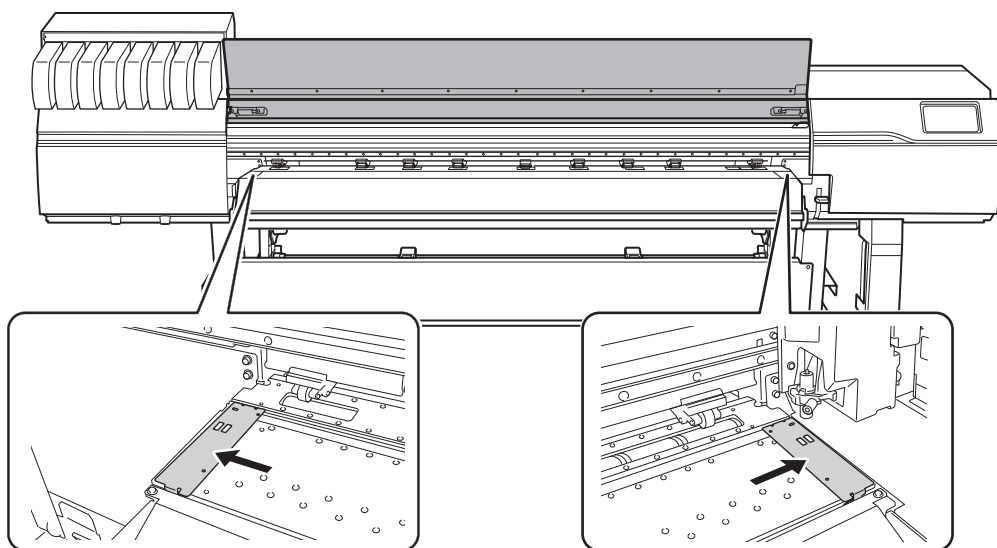

4. Release the locking mechanisms of the media holders, and then draw them to the left and right ends respectively.

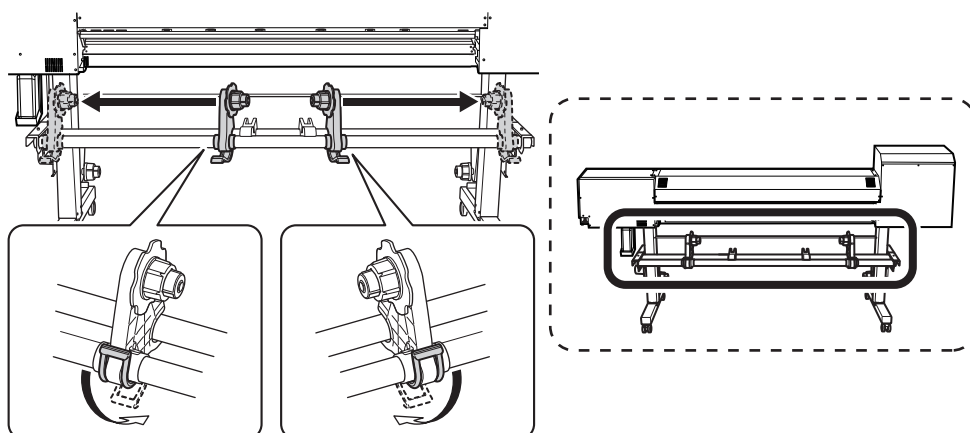

5. Move to the rear of the printer and open the rear UV shield.
 - a. Open the rear UV shield (①).

- b. Push the rear UV shield to the front of the machine, and then place this shield on the left and right stoppers (②).

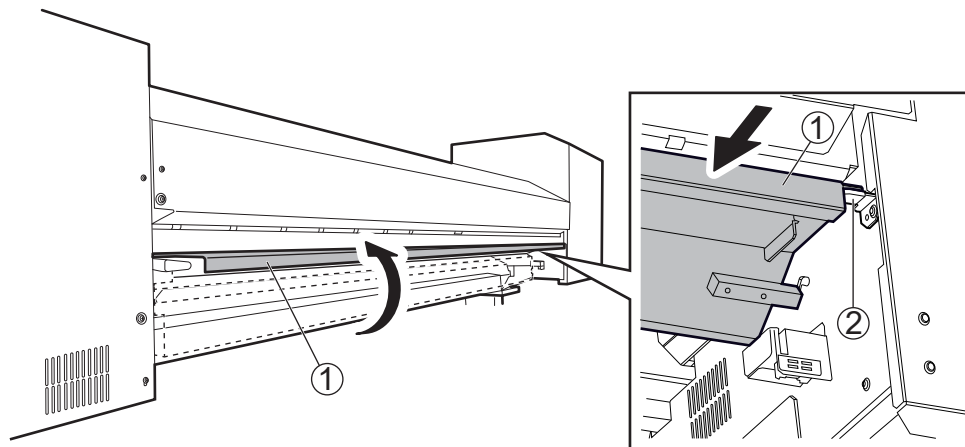

6. Pass the leading edge of the media between the pinch rollers (A) and the grit rollers (B).

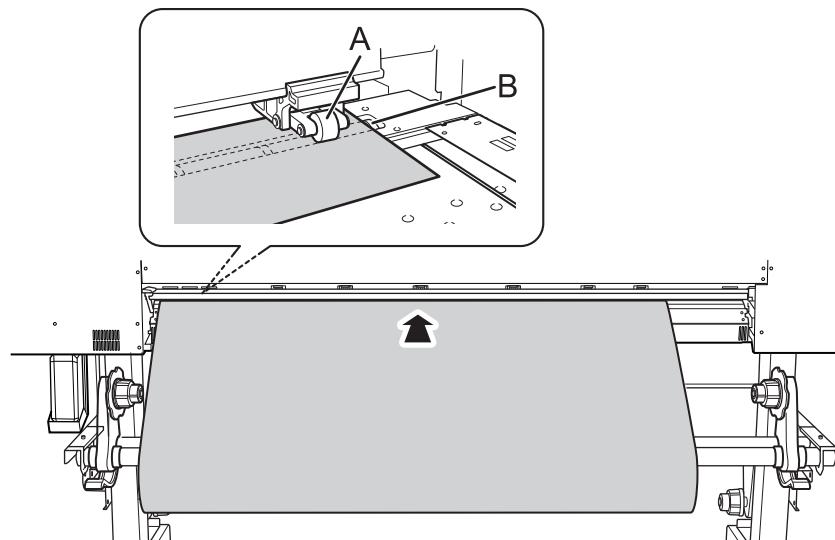

7. Lower the loading lever (rear).
The media is held in place.

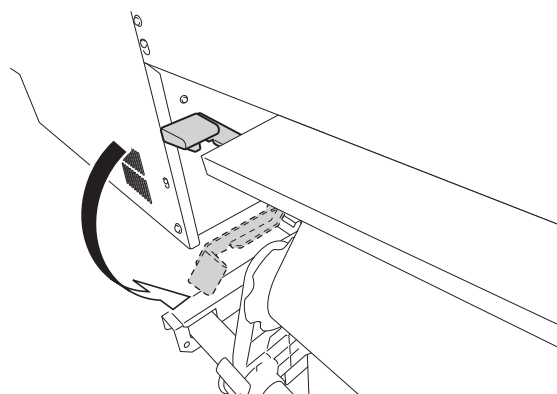

8. Close the rear UV shield.
- a. Pull the rear UV shield (①) to the back of the machine, and then remove this shield from the left and right stoppers (②).
- b. Close the rear UV shield.

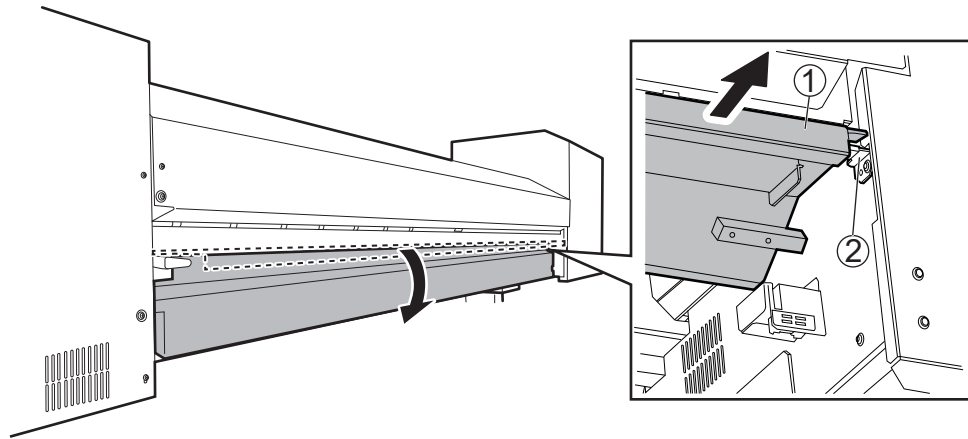

9. (Move to the front of the printer.) Gently hold down the media and raise the loading lever (front). The media is released.

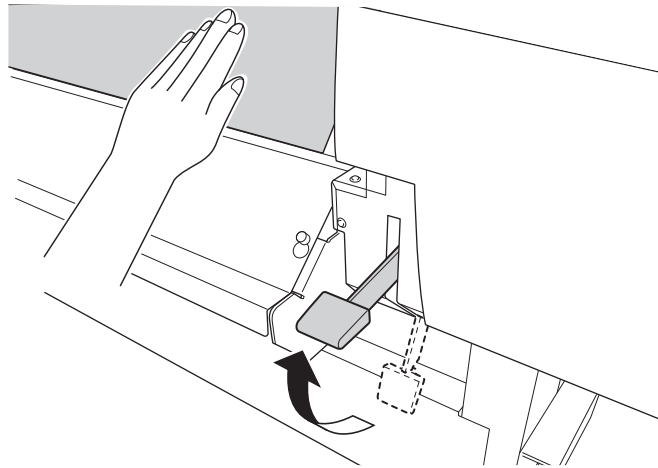

10. Make sure both edges of the media are above the grit rollers. Be sure to place the right edge of the media on the right-end grit roller.

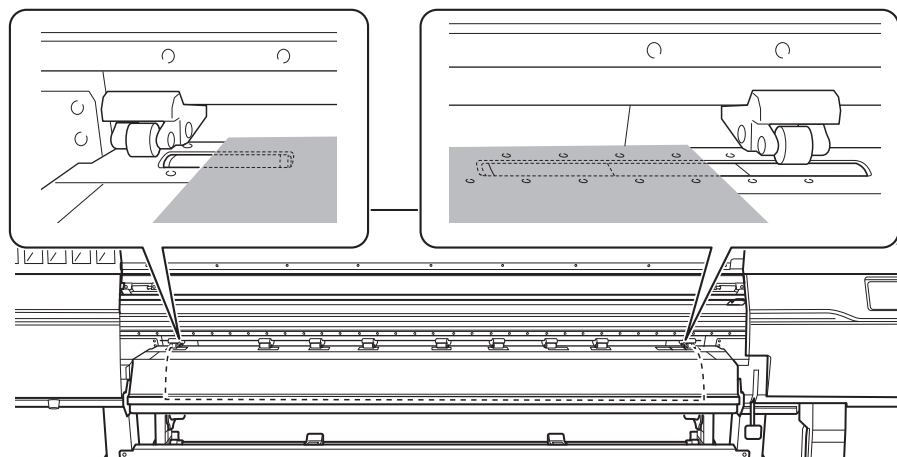

11. Move the left and right pinch rollers, placing them on both edges of the media. Position them approximately 10 mm (0.39 in.) from each edge of the media.

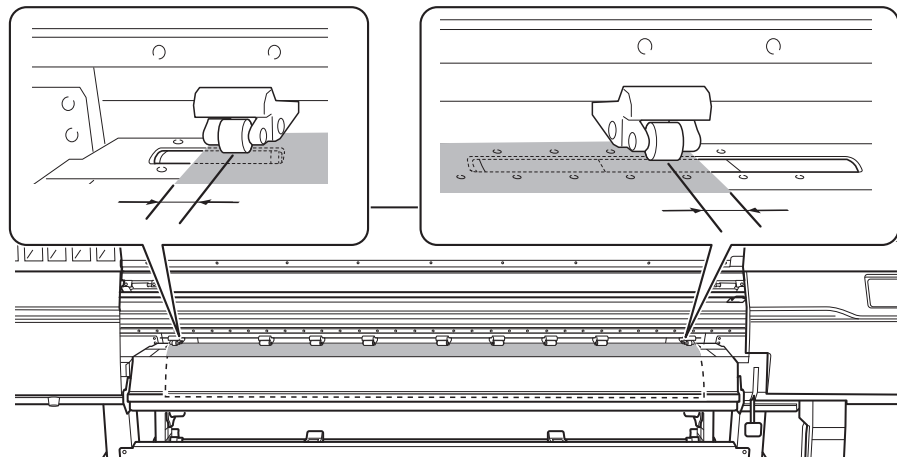

IMPORTANT

Be sure to use the left and right pinch rollers. The force with which the media is pinched varies between the middle pinch rollers and the left and right pinch rollers. Using the middle pinch rollers to pinch the media edges will lead to unstable media feeding.

MEMO

To smoothly move the pinch rollers, push down close to the rail.

12. Move the middle pinch rollers (B) over all the remaining grit rollers (A) covered by the media. There are grit patterns (C) wherever there are grit rollers.

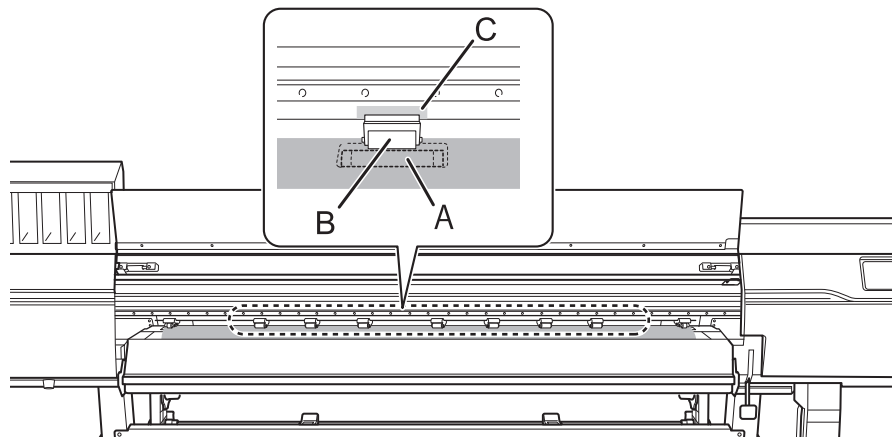

IMPORTANT

- Place the middle pinch rollers over all the grit patterns within the media width. If you have forgotten to place the middle pinch rollers, the media will be skewed during printing or will come loose, which will have an effect on the printing quality.
- The middle pinch roller will not lower onto the three grit rollers from the right end. Place the middle pinch roller on a grit roller other than these three.

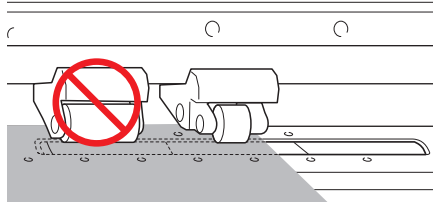

- There may be extra middle pinch rollers depending on the width of the media being used. Move the extra middle pinch rollers to positions where no grit patterns are present. Where no grit patterns are present, the middle pinch rollers will not come down.

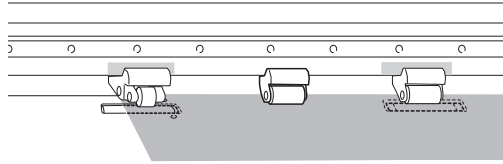

13. Lower the loading lever (front).

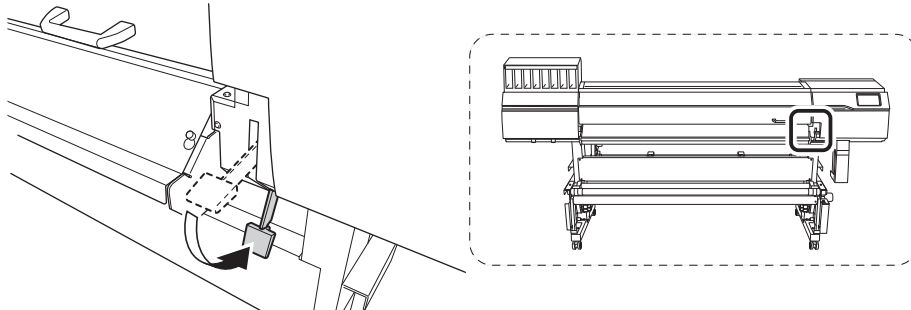

IMPORTANT

If you want to readjust the media position before securing it in place, redo the procedure from step 10.

14. Line up the edges of the media with the centers of the holes of the left and right media clamps.

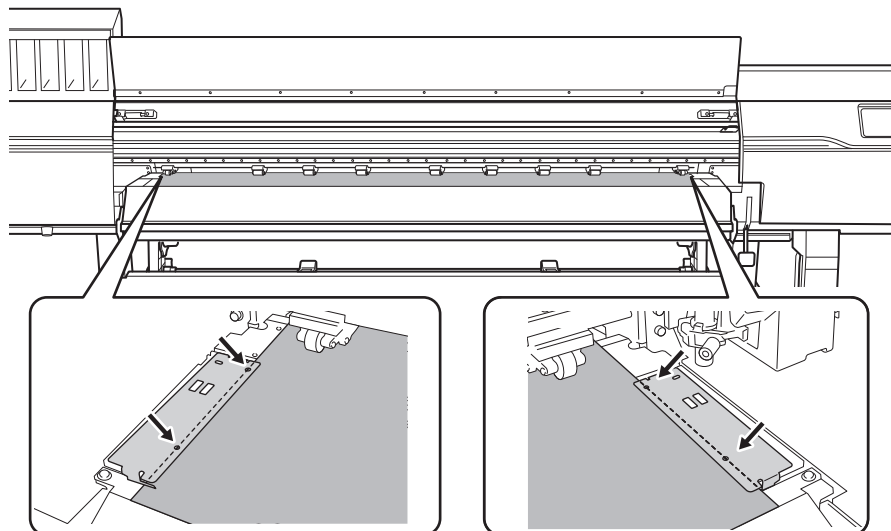

15. Close the front cover.

2. Register the media.

Procedure

1. Tap  [Setup].

2. Select [New].

3. Tap [Next].

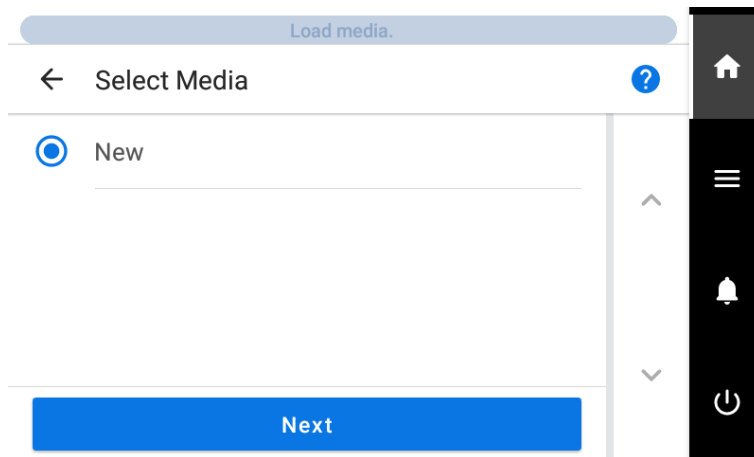

4. Enter a new media name and tap [OK].

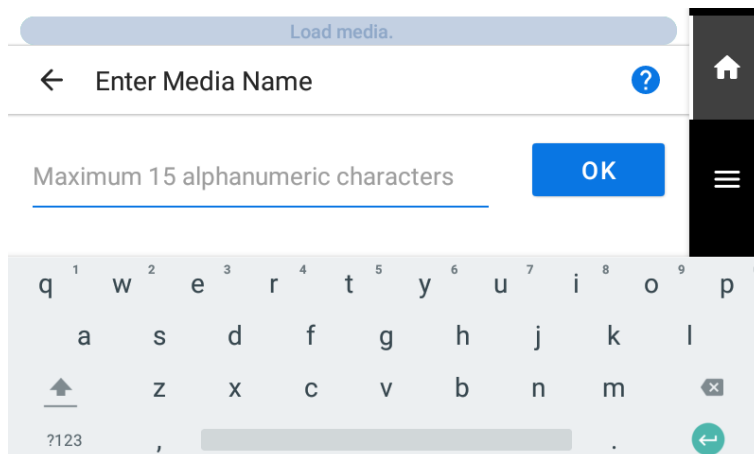

5. Tap [Next].

6. The [Setup Method] screen appears. Select whether to use the take-up unit.

7. Tap [Start Setup].

The cutting carriage moves and detects the width of the media and the positions of the media clamps. This operation is called initialization.

8. When [The media could not be detected automatically. Manually set the printing area.] appears, use the following procedure to configure the settings.



MEMO

This message may appear when media with high reflectance is set up.

(1) Tap [OK].

(2) Tap [Change].

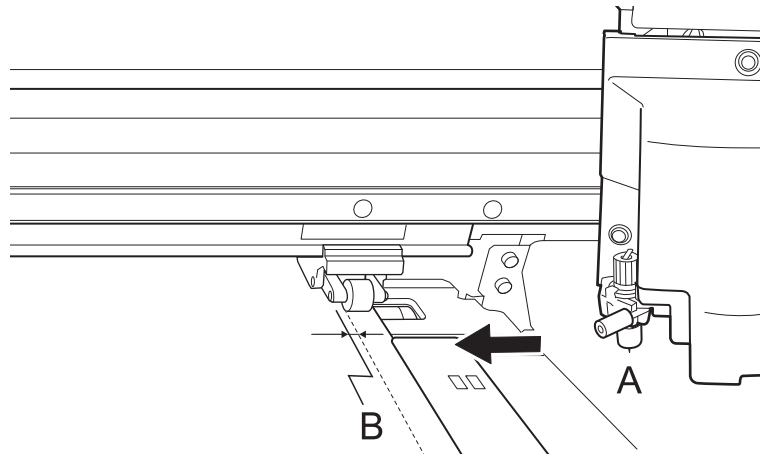

The [Set the right edge of the printing area within the area specified by the pinch rollers.] screen appears.

(3) Hold down  or  to move the center of the blade (A) approximately 2 mm (0.08 in.) to the inside (B) from the left edge of the right pinch roller.



(4) Tap [OK].

The [Set the left edge of the printing area within the area specified by the pinch rollers.] screen appears.

(5) Hold down  or  to move the center of the blade (A) approximately 2 mm (0.08 in.) to the inside (B) from the right edge of the left pinch roller.

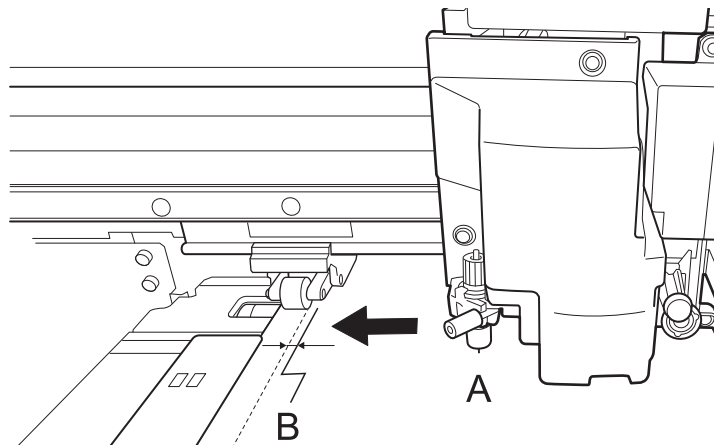

(6) Tap [OK].

The set left and right positions are applied to the [Printing Area (Width)].

(7) Tap [OK].

3. Configure settings to match the media.

To ensure the optimal output according to the media size and type, set the minimal amount of items. All items set here can be set individually as well.

Procedure

1. On the [Select Media Output Type] screen, select the output type and tap [Next].
 - [Print Only/Print & Cut]
Proceed to step 2.
 - [Cut Only]
Switch to the [Multi Sensor Adjustment] screen. When automatic adjustment is finished, tap [OK]. This completes the settings for [Cut Only].
If the adjustment failed, respond to the failure according to the information in [Correcting the Reading Sensor\(P. 206\)](#).
2. Use the [Print Head Height] screen to adjust the print head height.
 - If this is not necessary, tap [Next].
 - Follow the procedure below to make adjustments.
 - a. Tap [Change]
 - b. Open the front cover.
 - c. Move the height-adjustment lever to adjust the head height.
 - d. Close the front cover.
 - e. Tap [OK].
 - f. Tap [Next].
 For details on this work, refer to [Changing the Print Head Height\(P. 172\)](#).
3. On the [Nozzle Drop-out Test] screen, configure the [Printing Test] and [Output Start Location] settings.
 - If this is not necessary, tap [Next].
 - To perform a [Printing Test], tap [Printing Test]>[Execute]. For details on what to do after the printing test, refer to [Step 2: Normal Cleaning Method\(P. 134\)](#).
4. On the [Select Media Adjustment Method] screen, select the adjustment method.
Here, the media feed correction for reducing horizontal bands and the correction of the landing position of the ink will be adjusted.

MEMO

[Simple Correction (Auto)] is the recommended adjustment. You can determine the correction values with [Detailed Correction (Manual)].

- Follow the procedure below to make automatic adjustments.
 - a. Tap [Simple Correction (Auto)]>[Next].
 - b. Tap [Execute] on the [Batch Automatic Correction] screen.
On successful completion of automatic adjustment, the home screen appears. This completes the settings.
For more information, refer to [Automatically Making Required Adjustments\(P. 167\)](#).
- Follow the procedure below to make manual adjustments.
 - a. Tap [Detailed Correction (Manual)]>[Next].

-
- b. Tap **[Execute]** on the **[Multi Sensor Adjustment]** screen.
Adjust the reading sensor to the optimal condition. If the adjustment failed, respond to the failure according to the information in [Correcting the Reading Sensor\(P. 206\)](#).
 - c. Tap **[Next]**.
 - d. Perform a printing test on the **[Detailed Feed Correction (Manual)]** screen.
Set the correction value from the printing test result. For more information, refer to [Manual Adjustment: Reducing Horizontal Bands \(Feed Correction\)\(P. 168\)](#).
 - e. Tap **[Save and Proceed]**.
 - f. Perform a printing test on the **[Detailed Media Gap Adjustment (Manual)]** screen.
Set the correction values from the printing test result. For more information, refer to [Manual Adjustment: Adjusting the Misalignment of the Ink Landing Position \(Media Gap Adjustment\)\(P. 170\)](#).
 - g. Tap **[Save and Exit]**.

This completes the setup of the media.

Setup of Registered Media

⚠ CAUTION

Do not touch the dancer roller needlessly.

The media take-up unit and feeder may move suddenly, which may result in injury.

Setup of Roll Media

Load the roll media on the printer. When the loading is finished, [Output possible.] is displayed as the status. This work is referred to as "Setup of Media."

⚠ CAUTION

Load the roll media correctly.

Otherwise the media may fall and cause injury.

⚠ CAUTION

The roll media is approximately 45 kg (99.21 lb.) (54-inch model: 35 kg [77.16 lb.], 30-inch model: 30 kg [66.14 lb.]).

To avoid injury, handle the roll media with care.

⚠ CAUTION

Never load media that weighs over 45 kg (99.21 lb.) (54-inch model: 35 kg [77.16 lb.], 30-inch model: 30 kg [66.14 lb.]).

The machine may fail to withstand the weight and tip over or cause the media to fall.

1. Install the media on the media holders.

The media holders of this machine are designed to be used with a paper tube (core) with an inner diameter of 2 inches or 3 inches.

⚠ WARNING

Handling roll media is an operation that must be performed by 2 persons or more, and care must be taken to prevent falls.



Attempting to lift heavy media in a manner that taxes your strength may cause physical injury. Also, if dropped, such items may cause injury.

Procedure

1. Tap  on the operation panel.

The sub power is switched on.

2. When using a take-up unit, use the following procedure to set it.

- (1) Tap .
- (2) Tap [Preferences]>[Take-up]>[Take-up Direction].
- (3) Select [Backward] or [Forward].
- (4) Tap [Save].
- (5) Tap  to go back to the original screen.

3. Open the front cover.

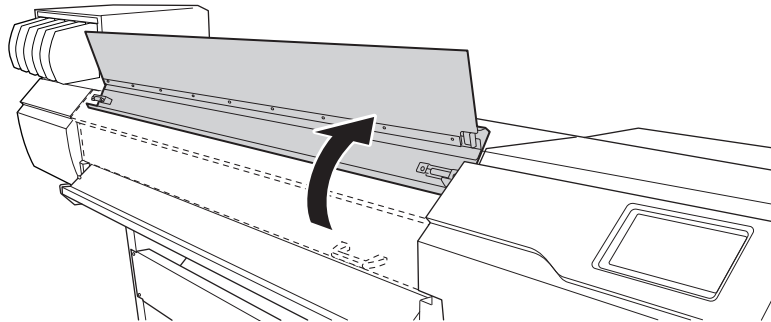

4. Move the media clamps to the outside of the grit rollers on the left and right edges respectively.

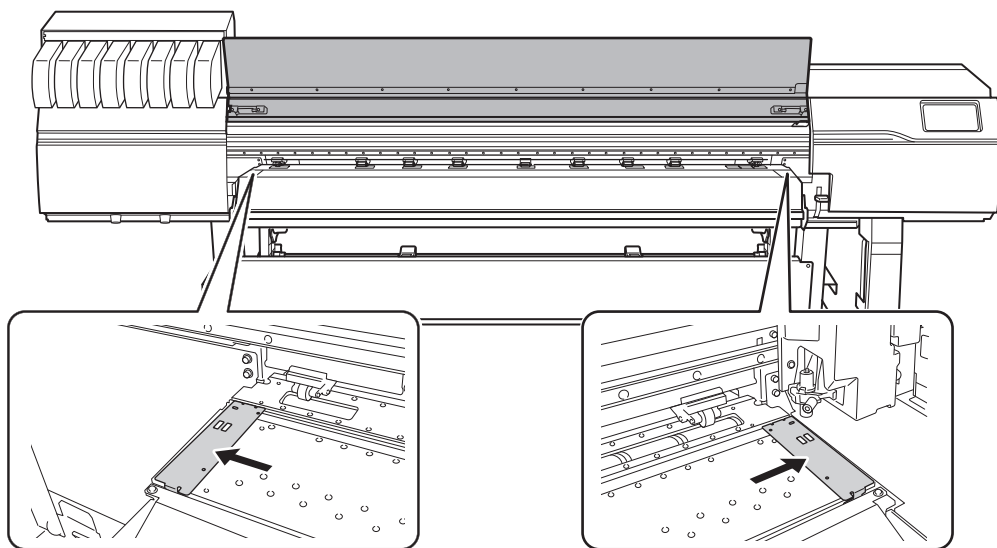

5. Move to the rear of the printer and open the rear UV shield.

- a. Open the rear UV shield (①).
- b. Push the rear UV shield to the front of the machine, and then place this shield on the left and right stoppers (②).

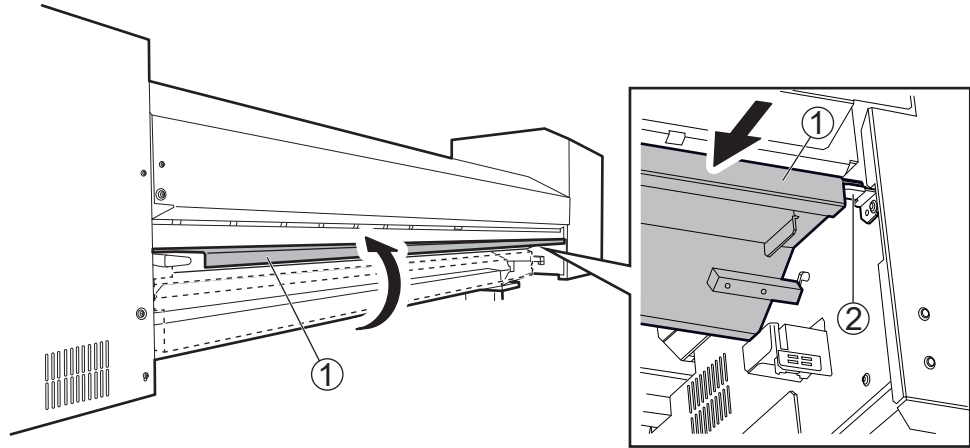

6. Release the locking mechanisms of the media holders, and then draw them to the left and right ends respectively.

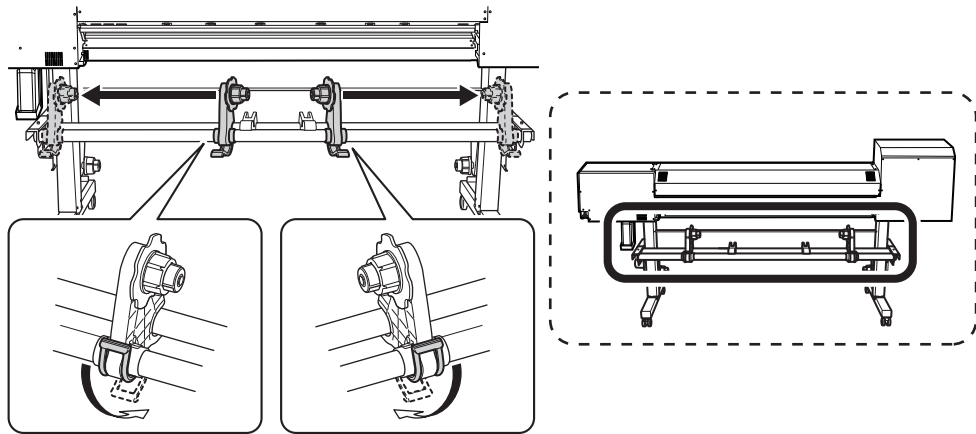

7. Place the media on the machine.

IMPORTANT

Do not leave media on the media stays or the pipes for a long period of time. The media may become deformed. Exercise caution.

- **Media with an outer diameter of 220 mm (8.66 in.) or less**

Place the media stays at positions that are 1/4 the length of the media from each end of the media, and then load the media.

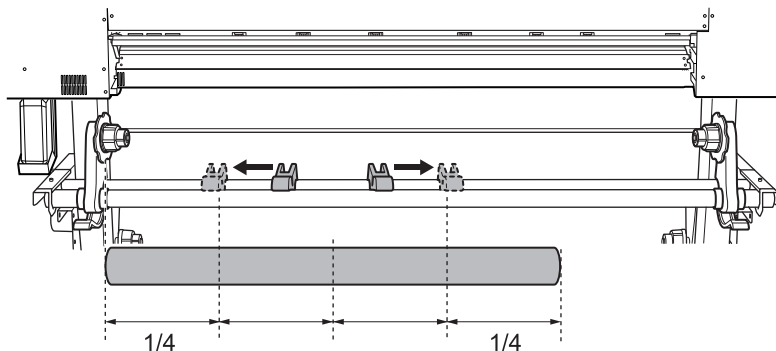

- **Media with an outer diameter exceeding 220 mm (8.67 in.)**
 - a. Rotate the media stays to draw them to the media holders.

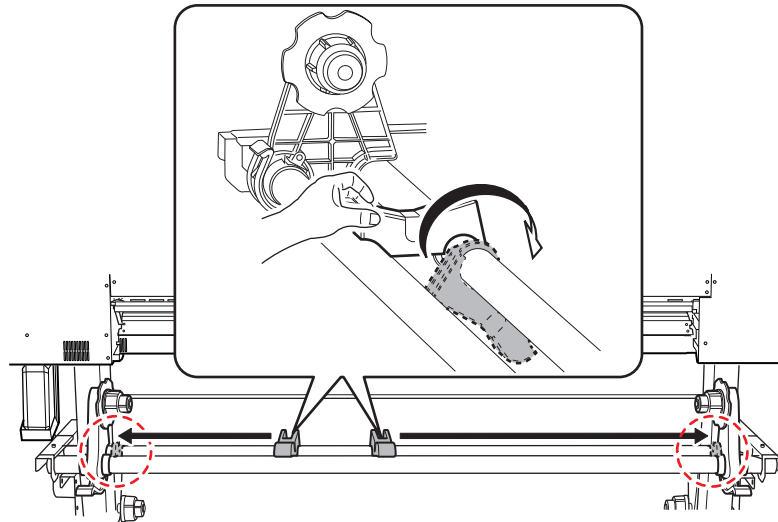

b. Place the media directly between the two pipes.

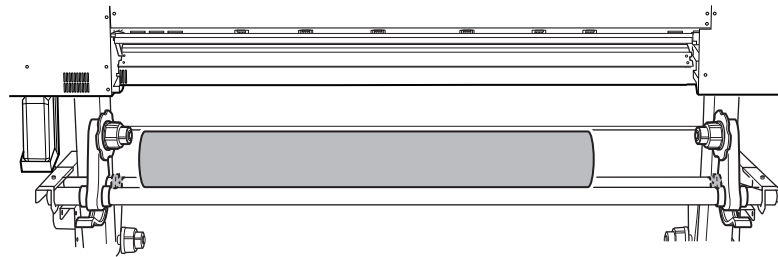

8. Fit the paper tube (core) of the media onto the end cap of the left media holder.

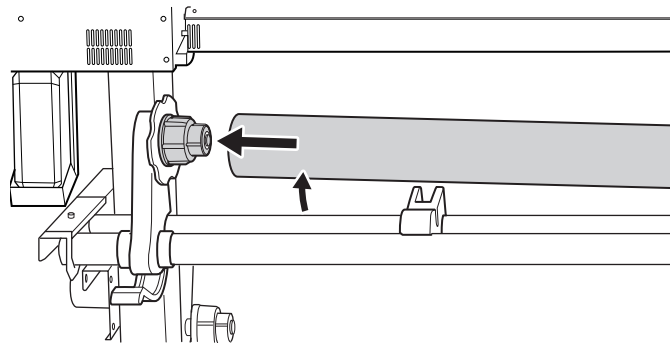

9. Move the right media holder to fit its end cap onto the paper tube (core) of the media.
Fit the paper tube onto the media holders securely to prevent the media from moving easily.

IMPORTANT

Do not secure the media holders in place just yet.

In the following procedure, you will adjust the positions of the media holders before securing them in place.
Do not secure them in place just yet.

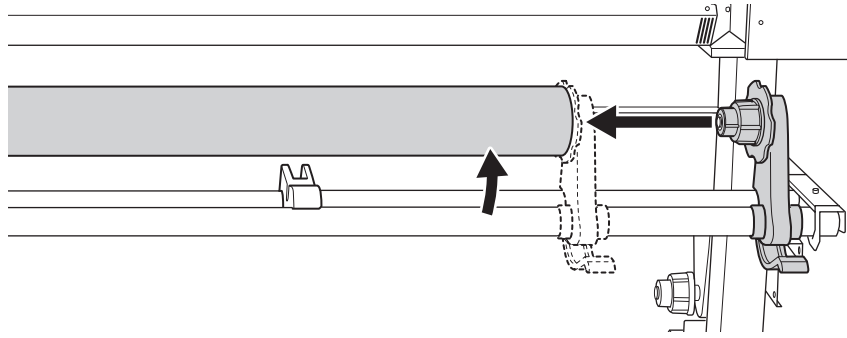

2. A: Determine the positions of the media.

This section describes how to use the suction fan to prevent media skewing. When using transparent media, whose edges cannot be detected, and when [Preferences]>[Media Edge Detection] is set to [Disable], the suction fan does not activate, so media cannot be loaded with this procedure. In these cases, refer to [2. B: Determine the positions of the media \(\[Media Edge Detection\]: \[Disable\]\).\(P. 81\)](#).

By default, [Skewing Correction Support at Setup] is set to [Enable].

Procedure

1. Determine the left and right positions of the media with the grit patterns used as the reference.

Note the following points when determining the positions.

- Hold the media holders from the outside and move them.
- Ensure that the left edge of the media is positioned so that it is within the range of the grit pattern of the left edge.
- Ensure that the right edge of the media is positioned so that it is within the range of one of the grit patterns.

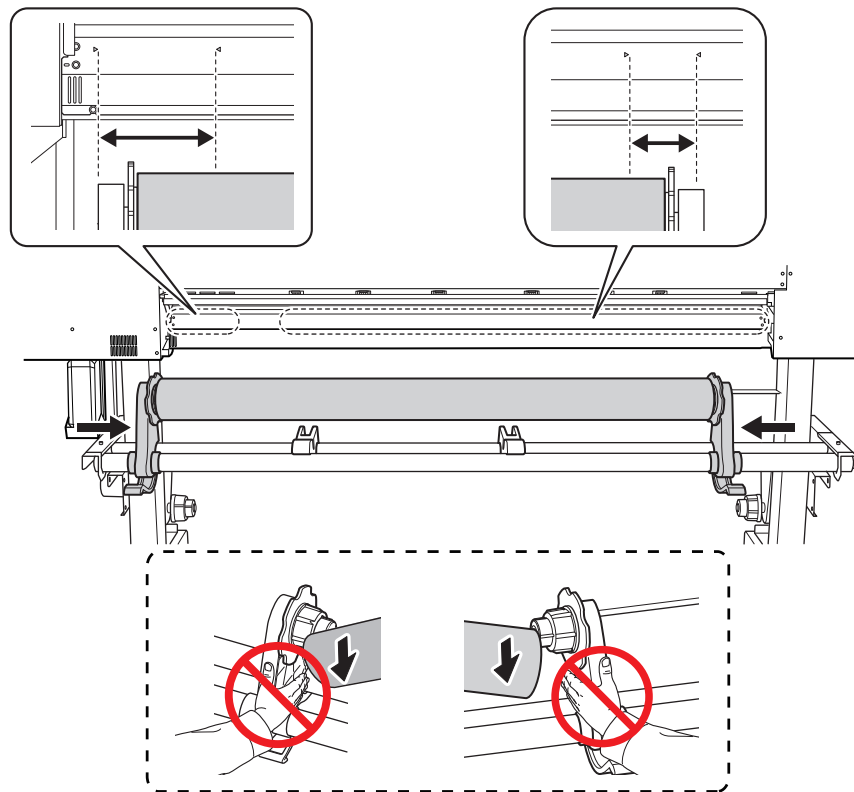

⚠ CAUTION

Do not hold places other than those instructed. Do not move the media by holding it directly.

Otherwise the media may fall off the media holder and cause injury.

IMPORTANT

Firmly decide the left and right side positions of the media at this point.

After this procedure is completed, if the left and right side positions do not fit the proper positions when securing the media with pinch rollers, you will have to go back to this step to redo this procedure. If you just

hold the media to readjust its position forcibly, the media will be skewed during printing, which will have an adverse effect on the printing results.

2. Secure the media holders.

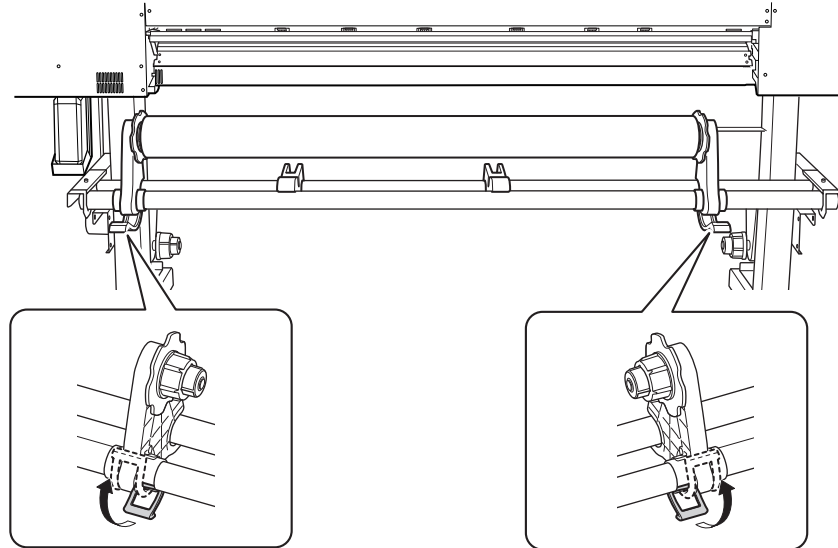

3. Use the following procedure to load the media.

Doing so will prevent media skewing.

- (1) Pass the leading edge of the media between the pinch rollers (A) and the grit rollers (B).

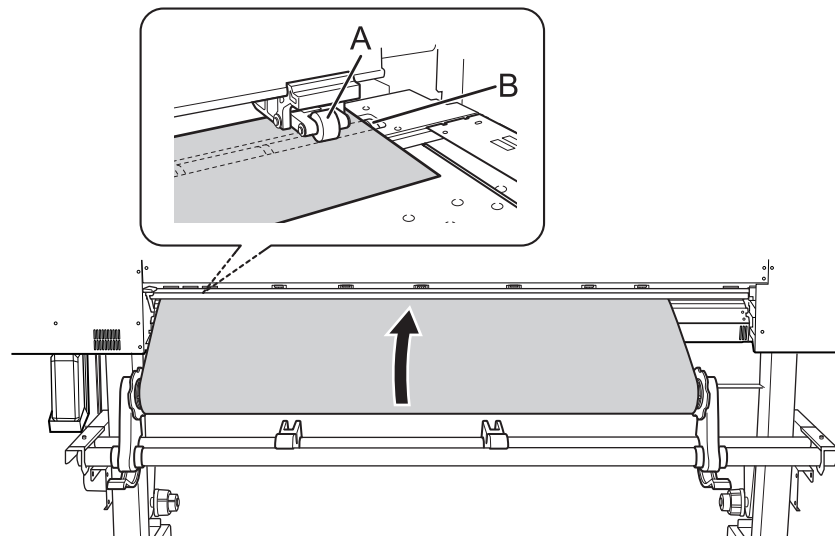

- (2) Feed the media until you hear a beep, and then additionally feed approximately 20 cm (7.87 in.) of the media.

You will hear a beep. Approximately 5 seconds later, you will hear two beeps, and then the suction fan will activate. While this fan is operating, the position of the media will be maintained even if you remove your hands from it.

- (3) Hold the media holder flange, turning it in the take-up direction to eliminate the slack in the media.

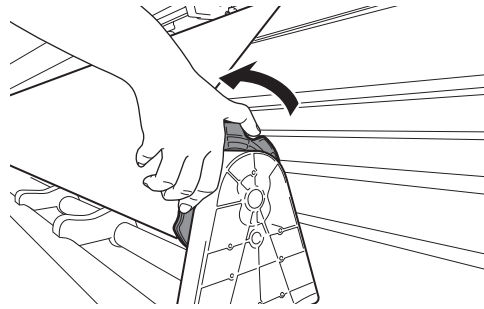

(4) Once the media is taut, additionally take up approximately 10 cm (3.94 in.) of media.

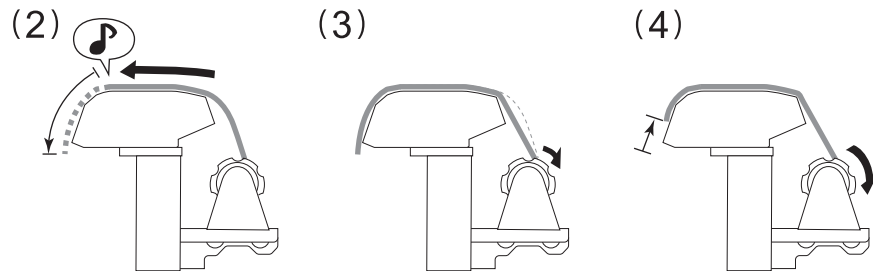

MEMO

If you take up too much media, you will hear two short beeps and the suction fan will stop. Take up the media, and then redo the procedure from step (1).

4. Close the rear UV shield.

- a. Pull the rear UV shield (①) to the back of the machine, and then remove this shield from the left and right stoppers (②).
- b. Close the rear UV shield.

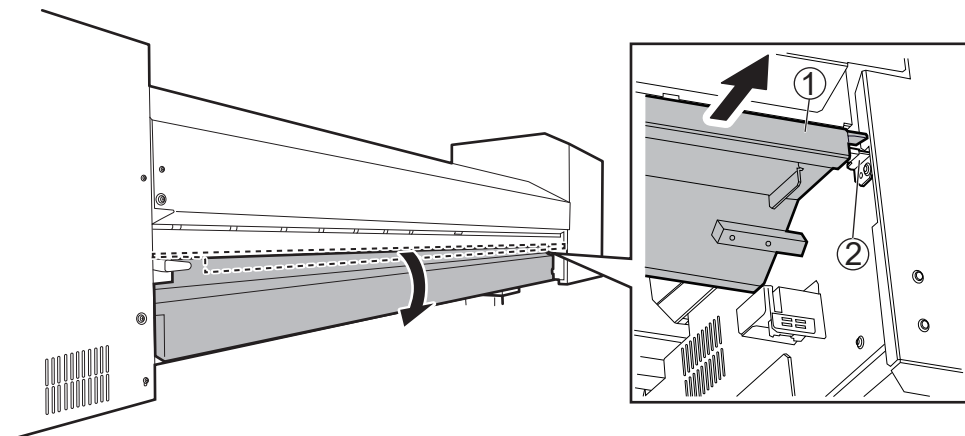

5. (Move to the front of the printer.) Make sure both edges of the media are above the grit rollers. Be sure to place the right edge of the media on the right-end grit roller.

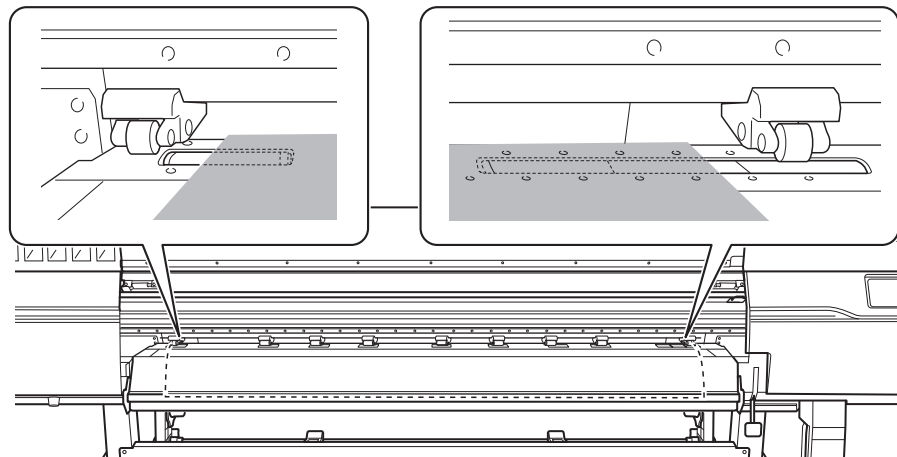

- 6. Move the left and right pinch rollers, placing them on both edges of the media.**
Position them approximately 10 mm (0.39 in.) from each edge of the media.

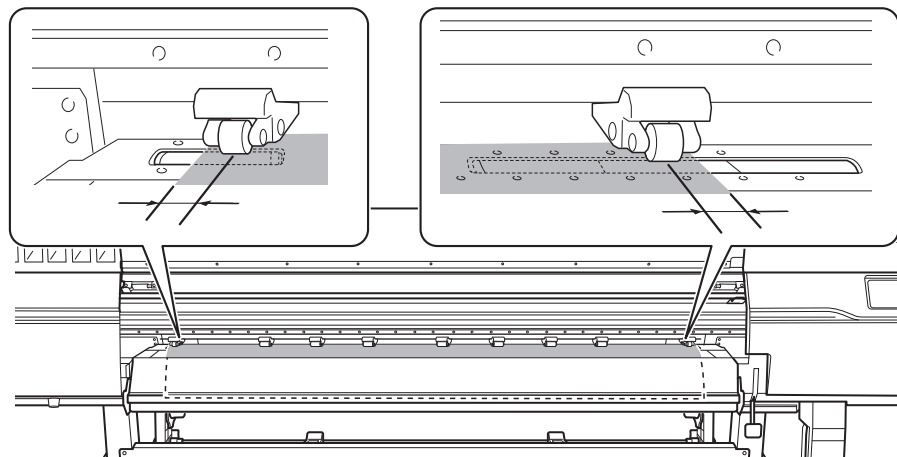

IMPORTANT

- Be sure to use the left and right pinch rollers. The force with which the media is pinched varies between the middle pinch rollers and the left and right pinch rollers. Using the middle pinch rollers to pinch the media edges will lead to unstable media feeding.
- If you want to readjust the media position, return to the back of the printer, release the media holders, and then redo the procedure from step 1. If you just stand at the front of the printer and hold the media to readjust its position forcibly, the media will be skewed during printing or will come loose, which will affect the printing quality.

MEMO

To smoothly move the pinch rollers, push down close to the rail.

- 7. Move the middle pinch rollers (B) over all the remaining grit rollers (A) covered by the media.**
There are grit patterns (C) wherever there are grit rollers.

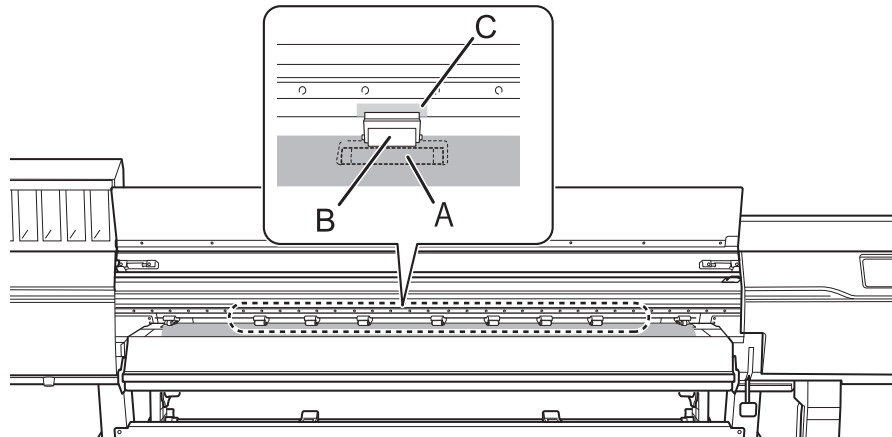
**IMPORTANT**

- Place the middle pinch rollers over all the grit patterns within the media width. If you have forgotten to place the middle pinch rollers, the media will be skewed during printing or will come loose, which will have an effect on the printing quality.
- The middle pinch roller will not lower onto the three grit rollers from the right end. Place the middle pinch roller on a grit roller other than these three.

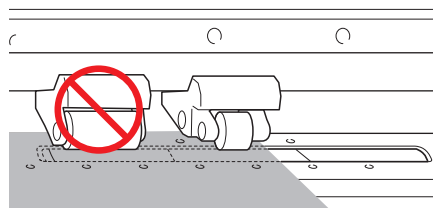

- There may be extra middle pinch rollers depending on the width of the media being used. Move the extra middle pinch rollers to positions where no grit patterns are present. Where no grit patterns are present, the middle pinch rollers will not come down.

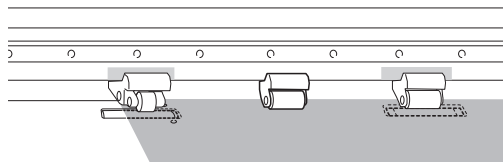
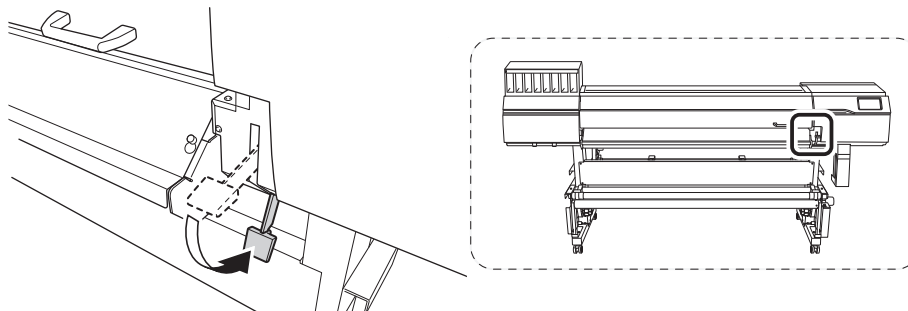
**8. Lower the loading lever (front).****IMPORTANT**

If you want to readjust the media position, return to the back of the printer, release the media holders, and then redo the procedure from step 1. If you just stand at the front of the printer and hold the media to readjust its position forcibly, the media will be skewed during printing or will come loose, which will affect the printing quality.

9. Line up the edges of the media with the centers of the holes of the left and right media clamps.

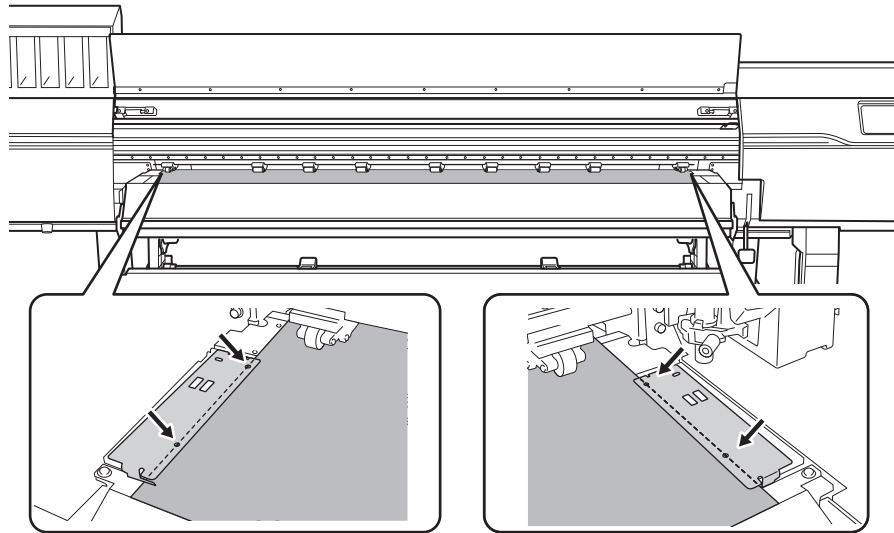

10. Close the front cover.

2. B: Determine the positions of the media ([Media Edge Detection]: [Disable]).

This section describes how to determine the positions of the media without using the suction fan. Refer to this information when using transparent media, whose edges cannot be detected, and when [Preferences]>[Media Edge Detection] is set to [Disable].

Procedure

1. Determine the left and right positions of the media with the grit patterns used as the reference.

Note the following points when determining the positions.

- Hold the media holders from the outside and move them.
- Ensure that the left edge of the media is positioned so that it is within the range of the grit pattern of the left edge.
- Ensure that the right edge of the media is positioned so that it is within the range of one of the grit patterns.

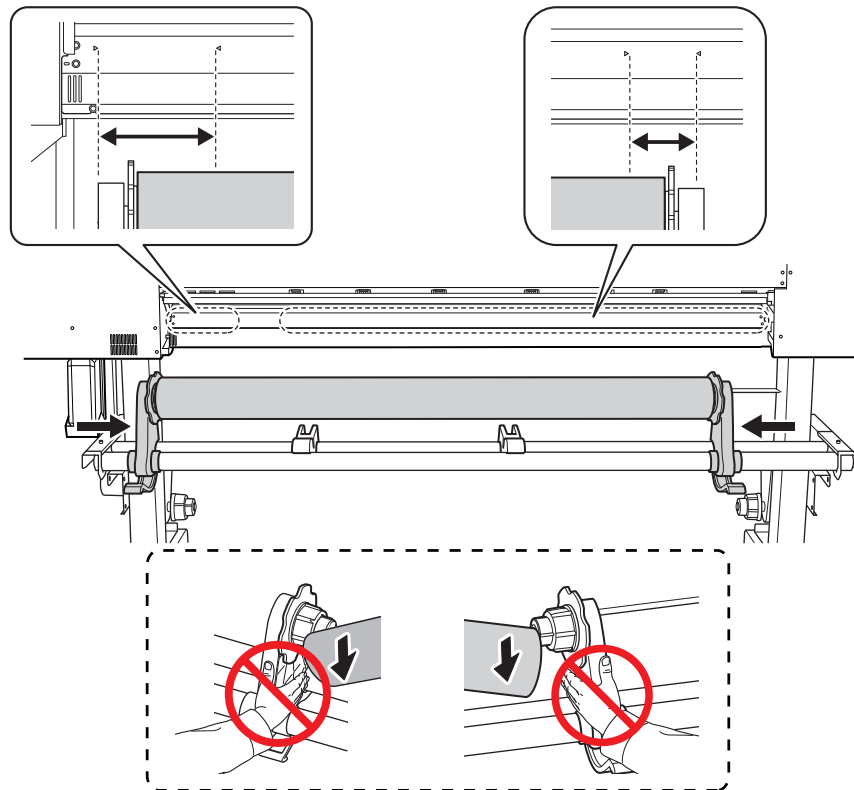

⚠ CAUTION

Do not hold places other than those instructed. Do not move the media by holding it directly.

Otherwise the media may fall off the media holder and cause injury.

IMPORTANT

Firmly decide the left and right side positions of the media at this point.

After this procedure is completed, if the left and right side positions do not fit the proper positions when securing the media with pinch rollers, you will have to go back to this step to redo this procedure. If you just hold the media to readjust its position forcibly, the media will be skewed during printing, which will have an adverse effect on the printing results.

2. Secure the media holders.

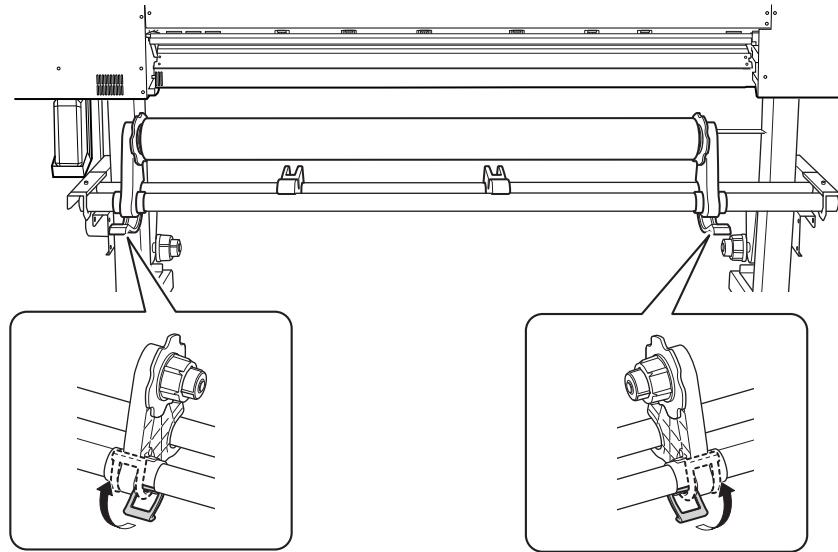

3. Pass the leading edge of the media between the pinch rollers (A) and the grit rollers (B).

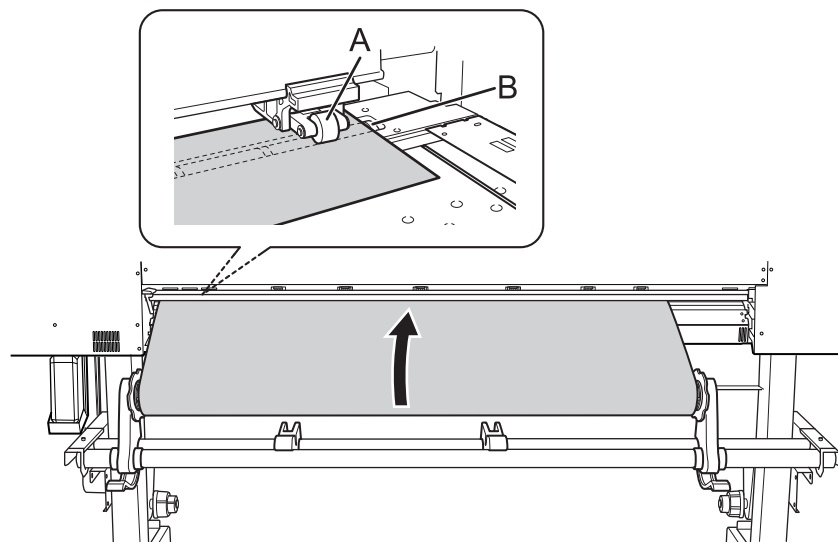

4. Lower the loading lever (rear).
The media is held in place.

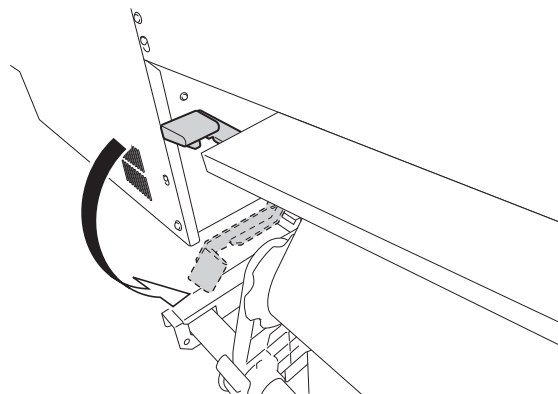

5. Close the rear UV shield.

- a. Pull the rear UV shield (①) to the back of the machine, and then remove this shield from the left and right stoppers (②).
- b. Close the rear UV shield.

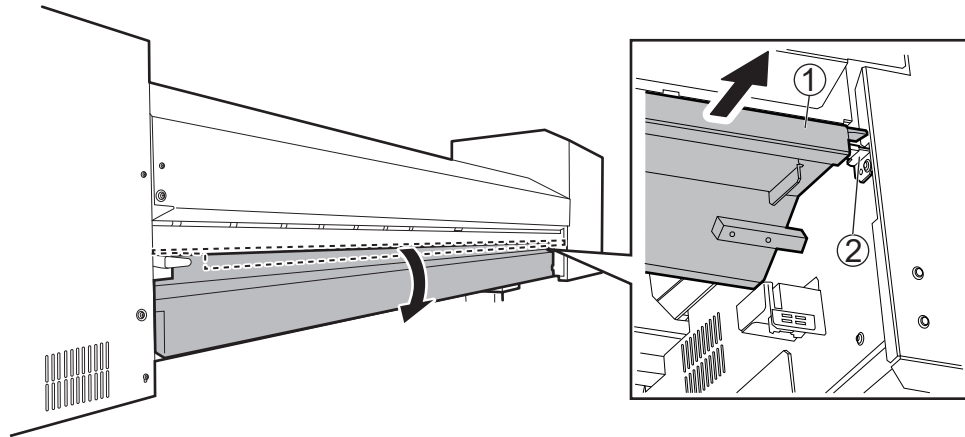

6. (Move to the front of the printer.) Gently hold down the media and raise the loading lever (front). The media is released.

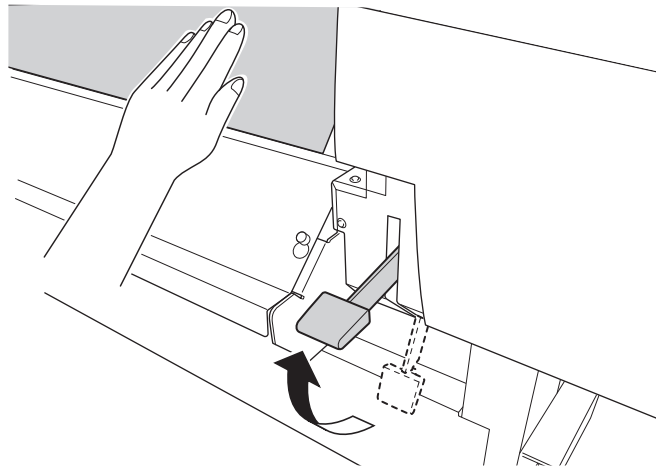

7. Pull out the media over the apron.

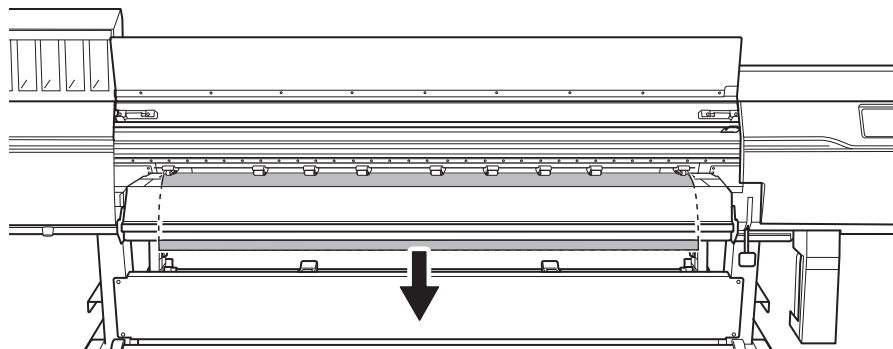

8. Make sure both edges of the media are above the grit rollers. Be sure to place the right edge of the media on the right-end grit roller.

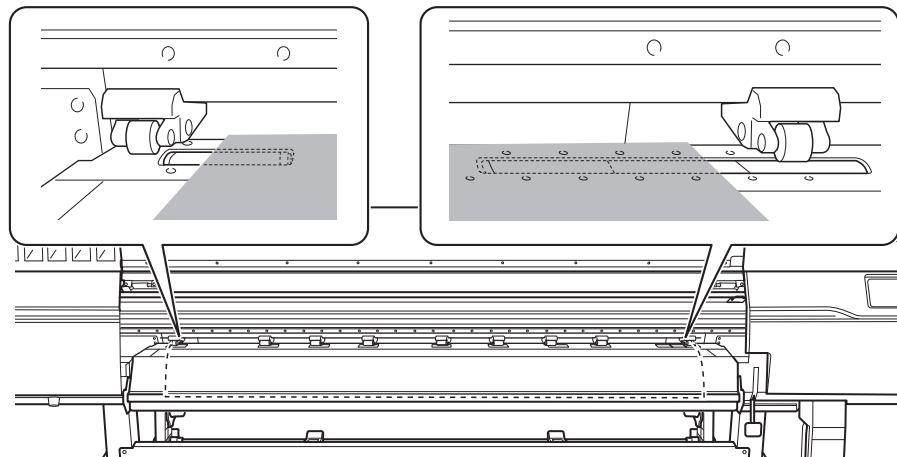

- 9. Move the left and right pinch rollers, placing them on both edges of the media.**
Position them approximately 10 mm (0.39 in.) from each edge of the media.

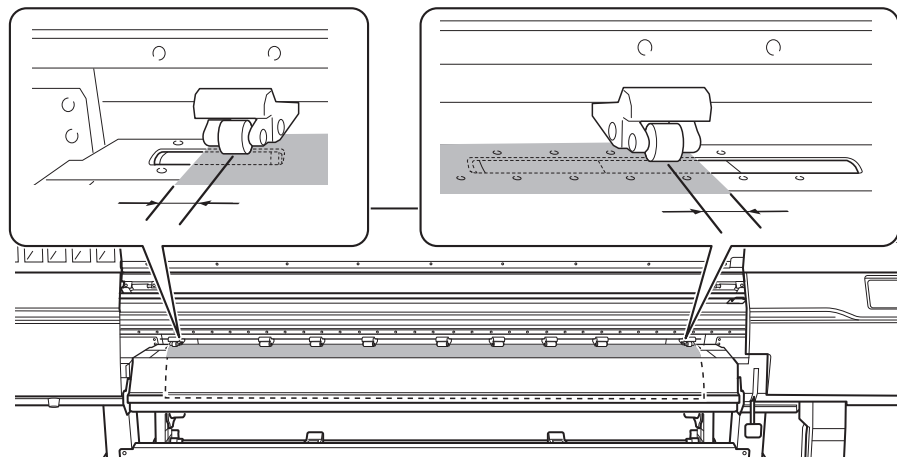

IMPORTANT

- Be sure to use the left and right pinch rollers. The force with which the media is pinched varies between the middle pinch rollers and the left and right pinch rollers. Using the middle pinch rollers to pinch the media edges will lead to unstable media feeding.
- If you want to readjust the media position, return to the back of the printer, release the media holders, and then redo the procedure from step 1. If you just stand at the front of the printer and hold the media to readjust its position forcibly, the media will be skewed during printing or will come loose, which will affect the printing quality.

MEMO

To smoothly move the pinch rollers, push down close to the rail.

- 10. Move the middle pinch rollers (B) over all the remaining grit rollers (A) covered by the media.**
There are grit patterns (C) wherever there are grit rollers.

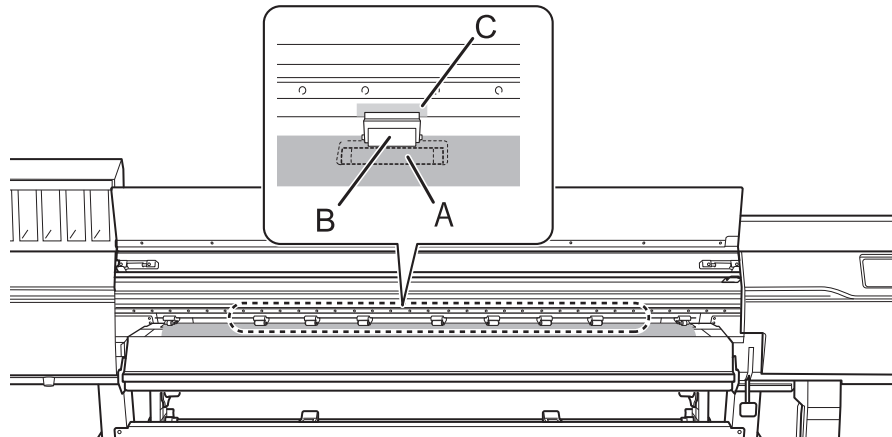

IMPORTANT

- Place the middle pinch rollers over all the grit patterns within the media width. If you have forgotten to place the middle pinch rollers, the media will be skewed during printing or will come loose, which will have an effect on the printing quality.
- The middle pinch roller will not lower onto the three grit rollers from the right end. Place the middle pinch roller on a grit roller other than these three.

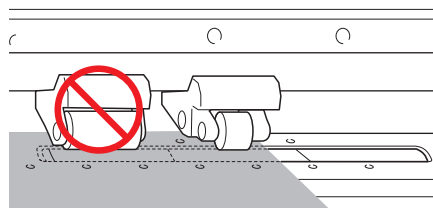

- There may be extra middle pinch rollers depending on the width of the media being used. Move the extra middle pinch rollers to positions where no grit patterns are present. Where no grit patterns are present, the middle pinch rollers will not come down.

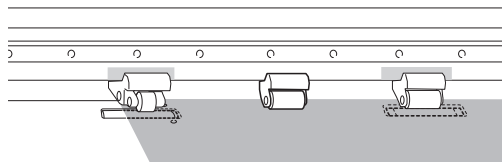

11. Hold the media at the center and pull it out, being sure to keep it straight and all areas of the media to be taut.

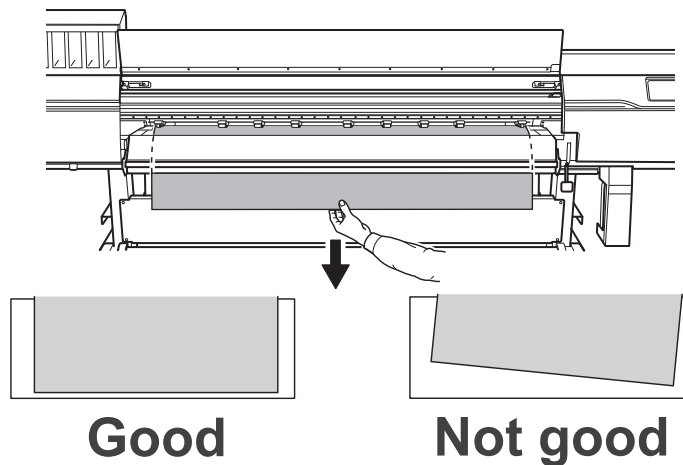

12. Lower the loading lever (front).

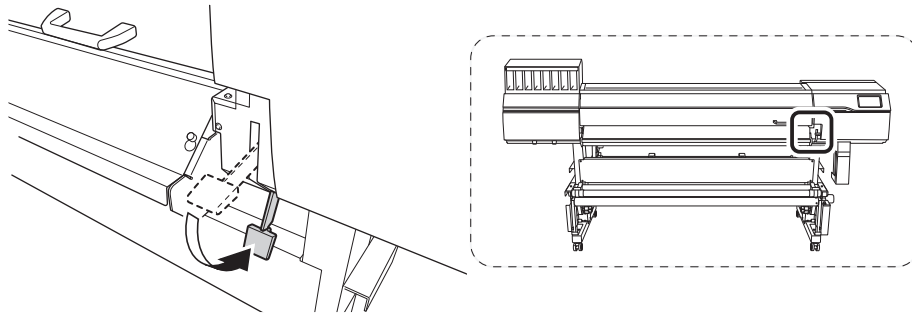

13. Line up the edges of the media with the centers of the holes of the left and right media clamps.

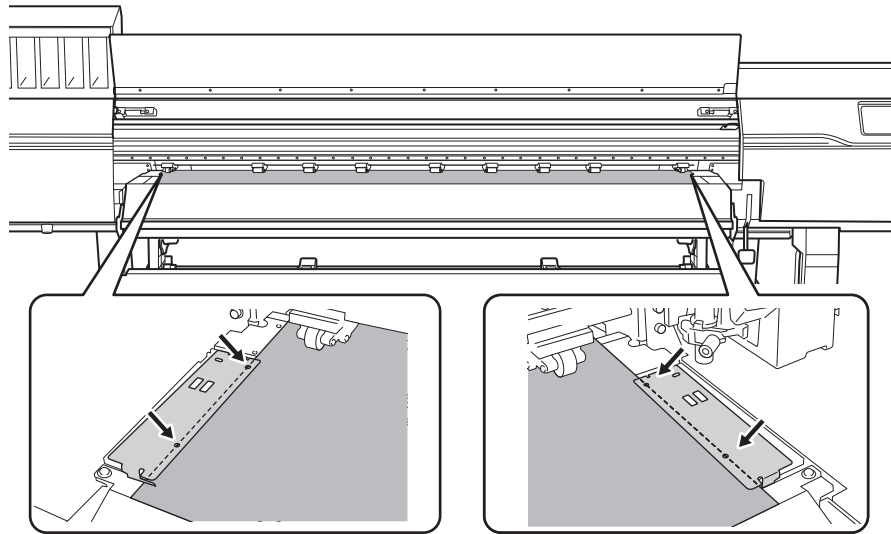

14. Close the front cover.

3. Select the media.

Procedure





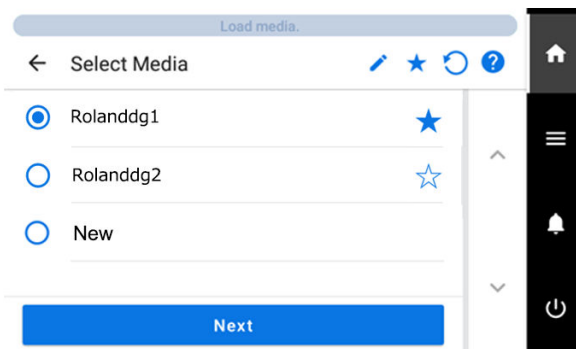



1. Tap  [Setup].

The registered media is displayed in a list.



2. Select the media name to use.

MEMO

- Tapping  makes it possible to search the registered media by keyword.
To reset the entered keyword, tap .
- Tapping  to the right of the media name will change the symbol to , and the media will be registered to Favorites.
Tap the favorites filter () at the top of the operation panel to turn the filter on () and show only favorited media.
Tap  to turn the Favorites filter off.
- Tap  to turn the Favorites filter off () and reset all keywords.
- Keyword searching and the Favorites filter can be used at the same time.



3. Tap [Next].
4. The [Setup Method] screen appears. Select whether to use the take-up unit.
5. Tap [Start Setup].
The cutting carriage moves and detects the width of the media and the positions of the media clamps. This operation is called initialization.
6. When [Printing Area (Width)] screen appears, use the following procedure to configure the settings.

MEMO

The media selected in step 2 is media whose printing area was set manually when registered as new media. The printing area must be set manually each time, so the [Printing Area (Width)] screen appears.

- (1) Tap [Change].

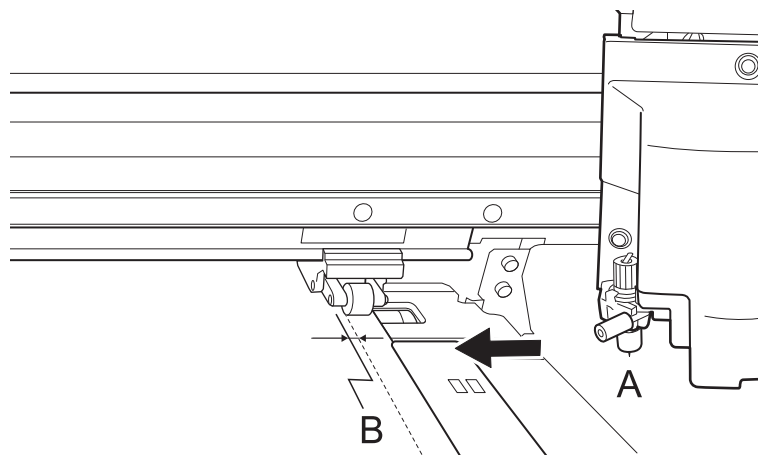

The [Set the right edge of the printing area within the area specified by the pinch rollers.] window appears.

- (2) Hold down  or  to move the center of the blade (A) approximately 2 mm (0.08 in.) to the inside (B) from the left edge of the right pinch roller.



- (3) Tap [OK].

The [Set the left edge of the printing area within the area specified by the pinch rollers.] window appears.

- (4) Hold down  or  to move the center of the blade (A) approximately 2 mm (0.08 in.) to the inside (B) from the right edge of the left pinch roller.

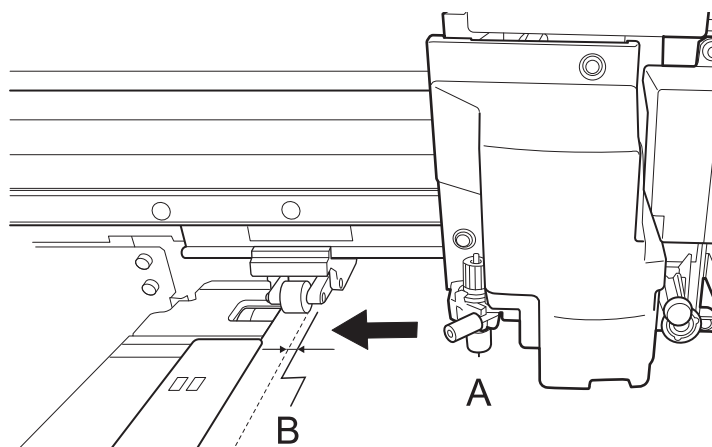

- (5) Tap [OK].

The set left and right positions are applied to the [Printing Area (Width)].

- (6) Tap [OK].

4. Load the media in the take-up unit.

If you will not use the take-up unit, setup is complete.

Procedure

1. Lower the dancer roller toward the rear.

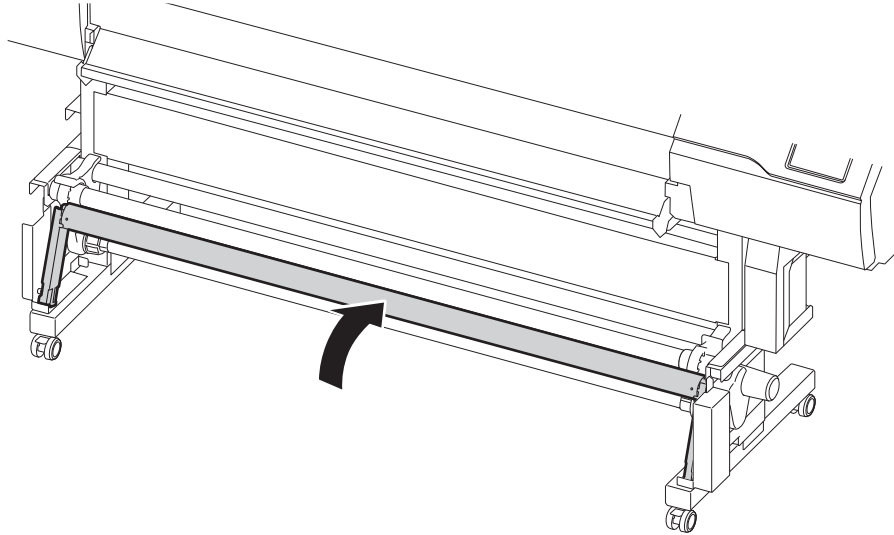

2. Follow the procedure below to load a paper tube on the media holders of the take-up unit.
Prepare a paper tube wider than the media that has been set up.

IMPORTANT

Paper tubes are consumable items.

Watch the condition of the paper tube and replace at an appropriate time so that the media can be taken up in good working order.

- (1) Release the media holders to enable their movement.

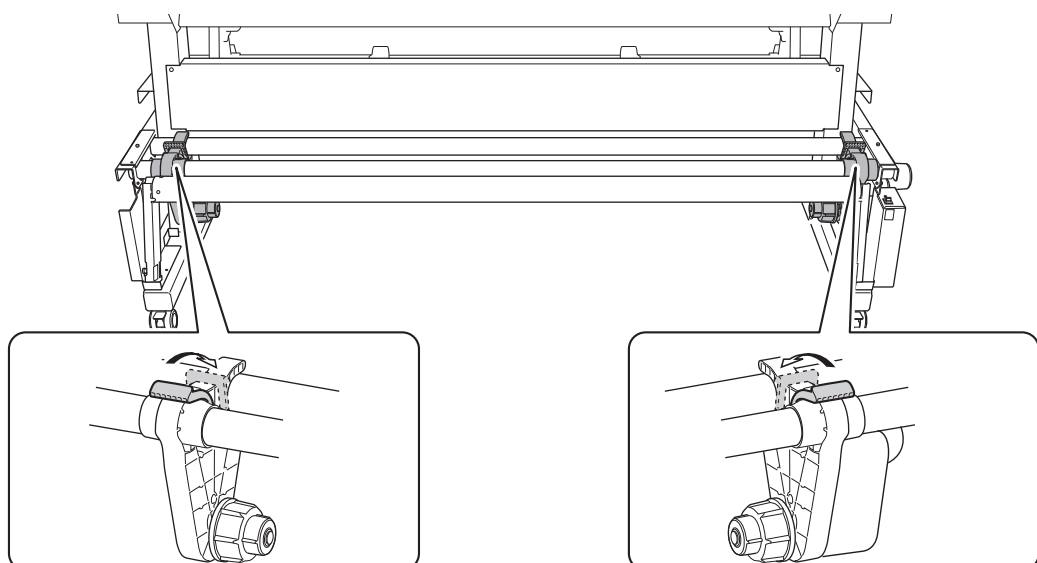

- (2) Fit the paper tube onto the right end cap.
Fit the paper tube securely right to the end of the end cap.
- (3) Push the left media holder into the paper tube.

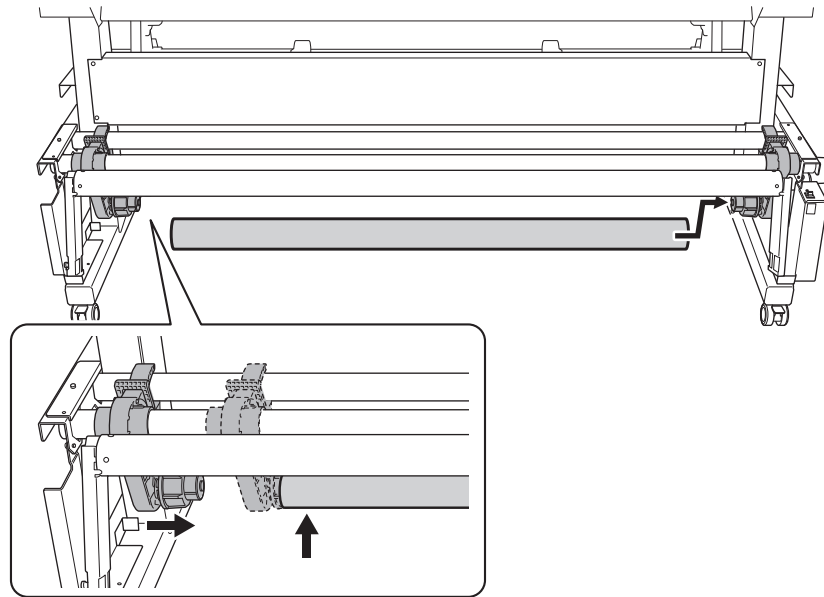

3. Hold down  on the operation panel to feed out the media until the tip of the media reaches the paper tube.

Media is fed out 10 mm (0.39 in.) each time you hold down this button. Holding down the button lets you feed out paper continuously.

Good

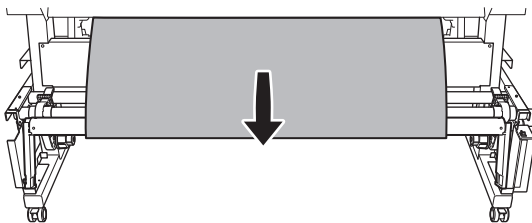

Not Good

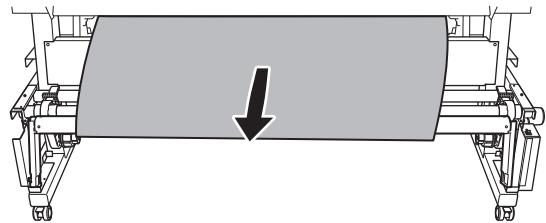

MEMO

Feed out the media until it can wrap around at least 1/4 of the paper tube.

When using the FORWARD setting	When using the BACKWARD setting

4. Follow the procedure below to adjust the positions of the media holders.
- (1) Move both media holders so that it is possible to see the paper tube from the right edge of the media.
Hold the media holders from the outside and move them.

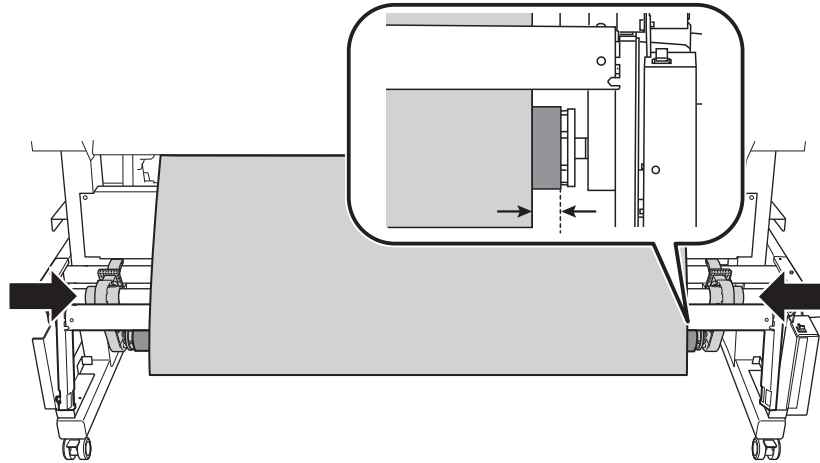

(2) Secure the left and right media holders.

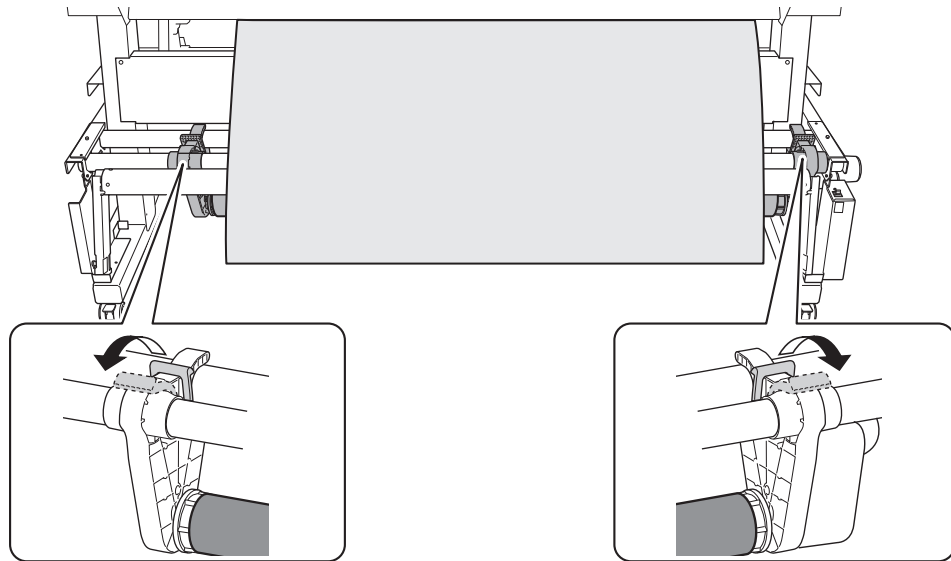

5. Follow the procedure below to secure the media on the paper tube.

Secure the media in the [Take-up Direction] set in step 2 of 1. [Install the media on the media holders.](#) (P. 70).

- (1) While pulling the media so that it does not sag, secure the center of the media on the paper tube with adhesive tape.
- (2) While pulling the media from the center toward the outer edges, secure the left and right edges of the media on the paper tube with adhesive tape.

- When using the FORWARD setting

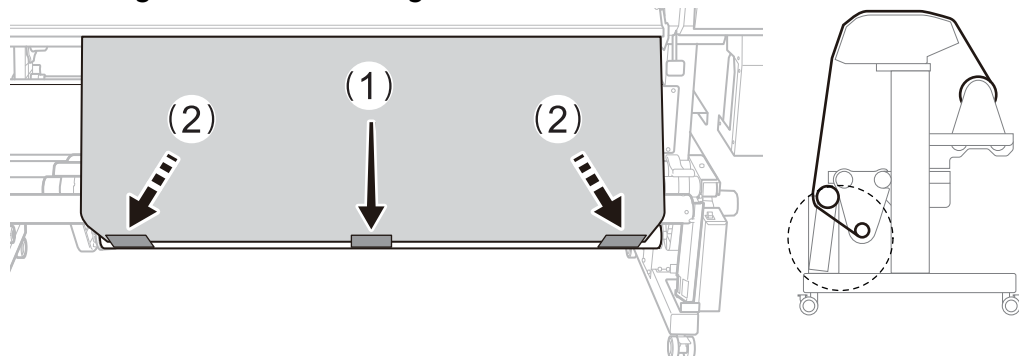

- When using the BACKWARD setting

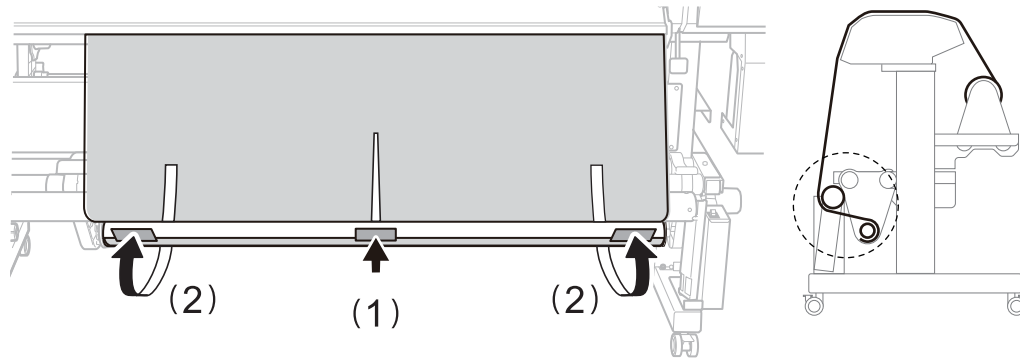

6. Tap [OK].
A small amount of the media is fed out.
7. Lower the dancer roller toward the front.

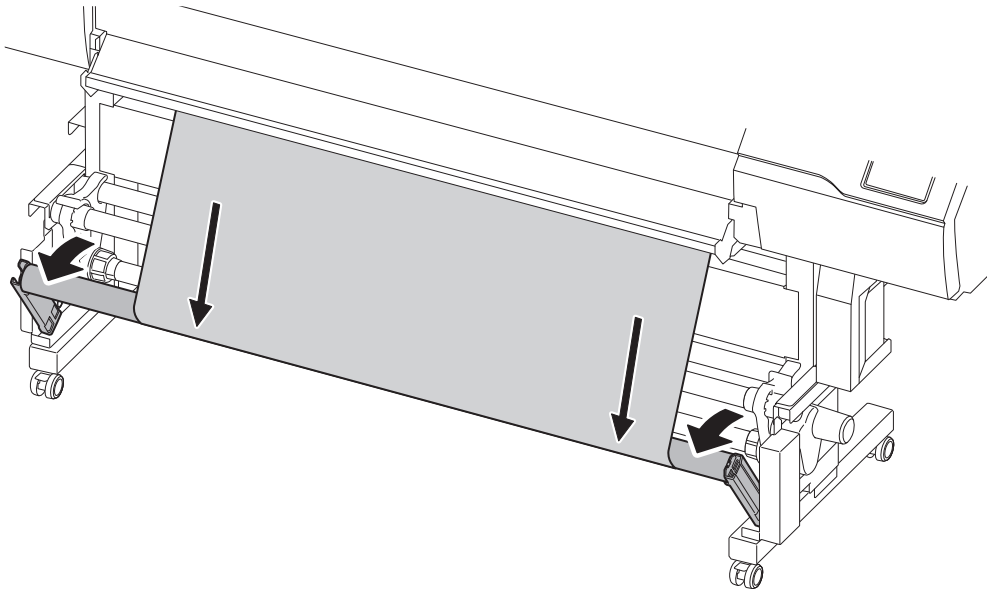

8. Tap [OK].

IMPORTANT

When printing and cutting or just cutting, rewind the media from the take-up device to slacken the media. If sufficient media is not wound on the paper tube immediately after setup, this operation may not be performed well, lowering the cutting quality and preventing continued take-up. When performing cutting immediately after attaching the media to the paper tube, first feed enough media to carry out take-up a few times and set the base point.

Setup of Sheet Media

Load the sheet media on the printer. When the loading is finished, [Output possible.] is displayed as the status. This work is referred to as "Setup of Media."

1. A: Determine the positions of the media.

When using transparent media, whose edges cannot be detected, and when [Preferences]>[Media Edge Detection] is set to [Disable], the suction fan does not activate, so media cannot be loaded with this procedure. In these cases, refer to [1. B: Determining the Positions of Media \(If \[Media Edge Detection\]: \[Disable\]\)\(P. 98\)](#).

By default, [Skewing Correction Support at Setup] is set to [Enable].

Procedure

1. Tap  on the operation panel.
The sub power is switched on.
2. Open the front cover.
3. Move the media clamps to the outside of the grit rollers on the left and right edges respectively.

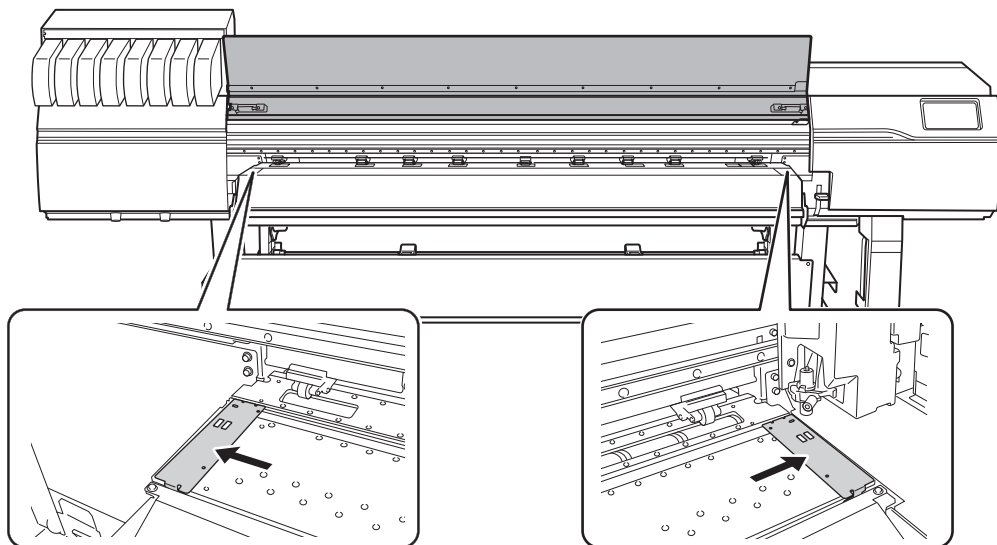

4. Release the locking mechanisms of the media holders, and then draw them to the left and right ends respectively.

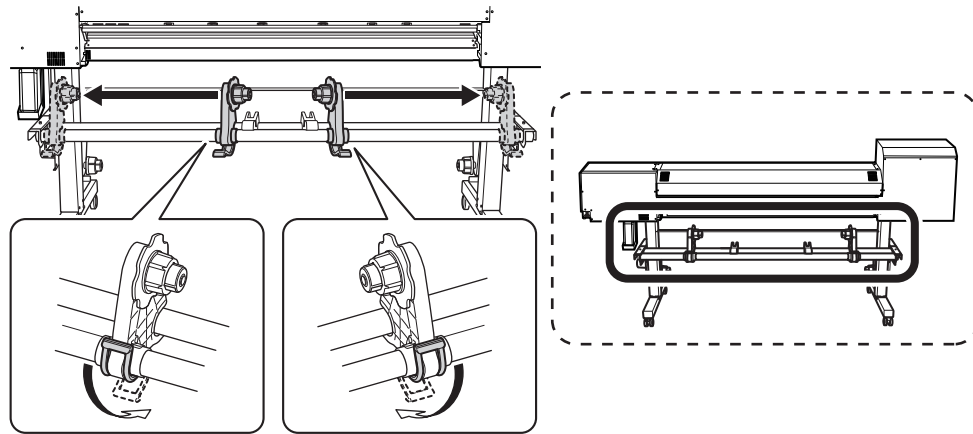

5. Move to the rear of the printer and open the rear UV shield.

- a. Open the rear UV shield (①).
- b. Push the rear UV shield to the front of the machine, and then place this shield on the left and right stoppers (②).

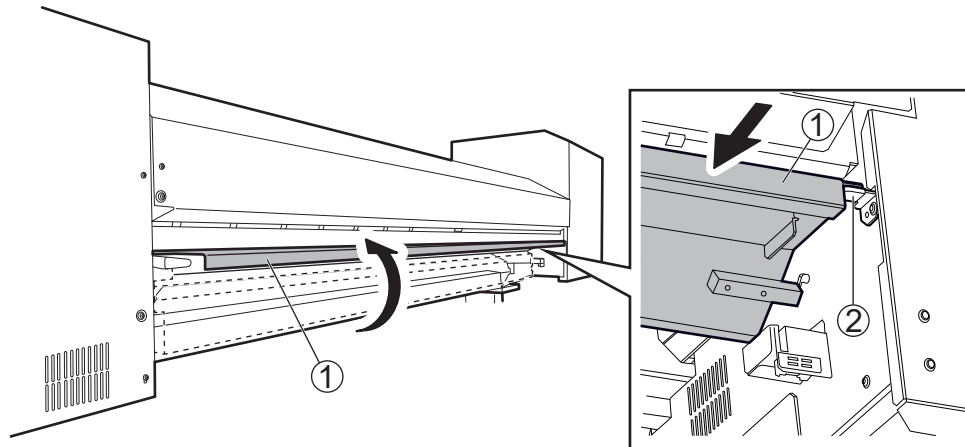

6. From the rear of the printer, pass the leading edge of the media between the pinch rollers (A) and the grit rollers (B).

You will hear a beep. Approximately 5 seconds later, you will hear two beeps, and then the suction fan will activate. While this fan is operating, the media will not move backward even if you remove your hands from it.

When loading the media from the front of the printer, feed the leading edge of the media (the side where printing will start) over the platen, and then pull the media to the front to activate the suction fan.

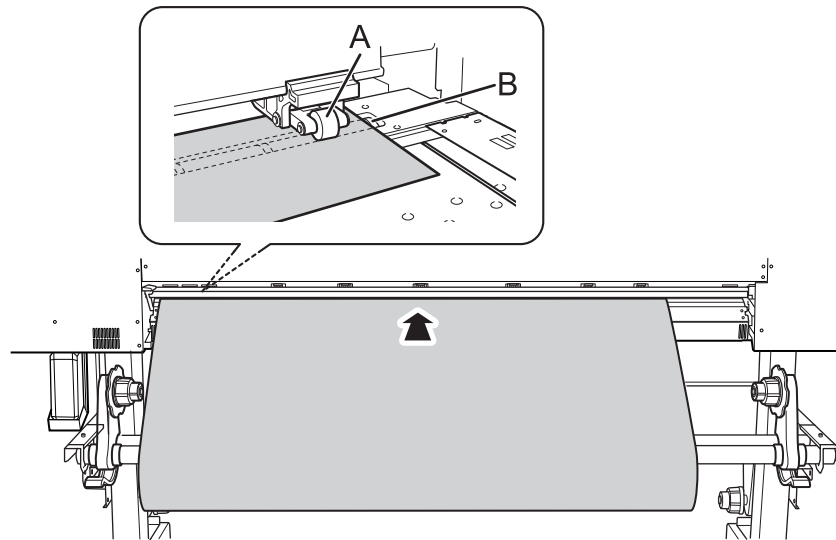

7. Close the rear UV shield.

- a. Pull the rear UV shield (①) to the back of the machine, and then remove this shield from the left and right stoppers (②).
- b. Close the rear UV shield.

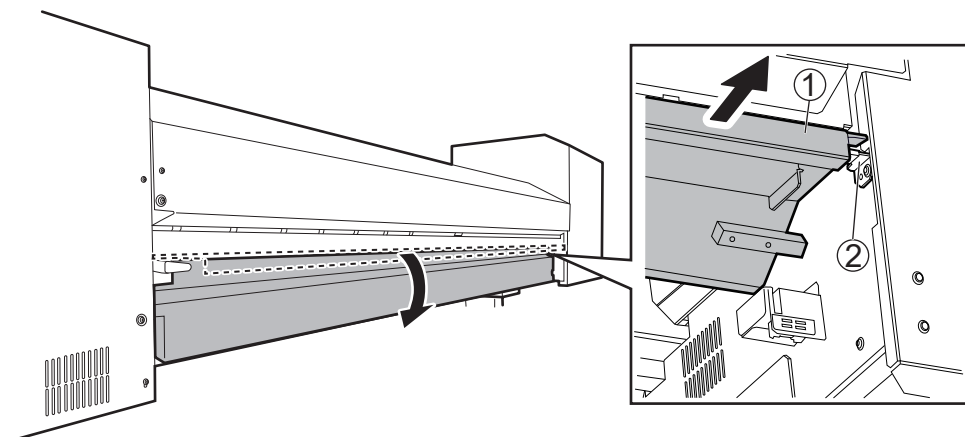

- 8. (Move to the front of the printer.) Make sure both edges of the media are above the grit rollers. Be sure to place the right edge of the media on the right-end grit roller.**

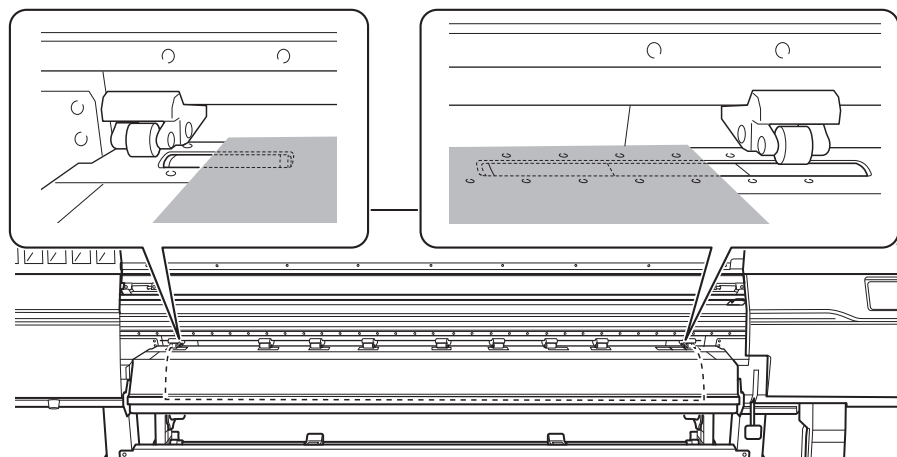

- 9. Move the left and right pinch rollers, placing them on both edges of the media.**

Position them approximately 10 mm (0.39 in.) from each edge of the media.

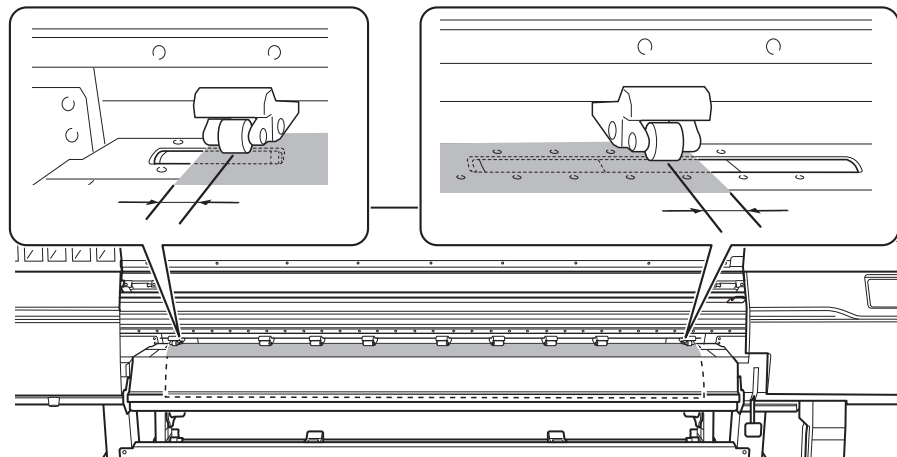

IMPORTANT

Be sure to use the left and right pinch rollers. The force with which the media is pinched varies between the middle pinch rollers and the left and right pinch rollers. Using the middle pinch rollers to pinch the media edges will lead to unstable media feeding.

MEMO

To smoothly move the pinch rollers, push down close to the rail.

10. Move the middle pinch rollers (B) over all the remaining grit rollers (A) covered by the media. There are grit patterns (C) wherever there are grit rollers.

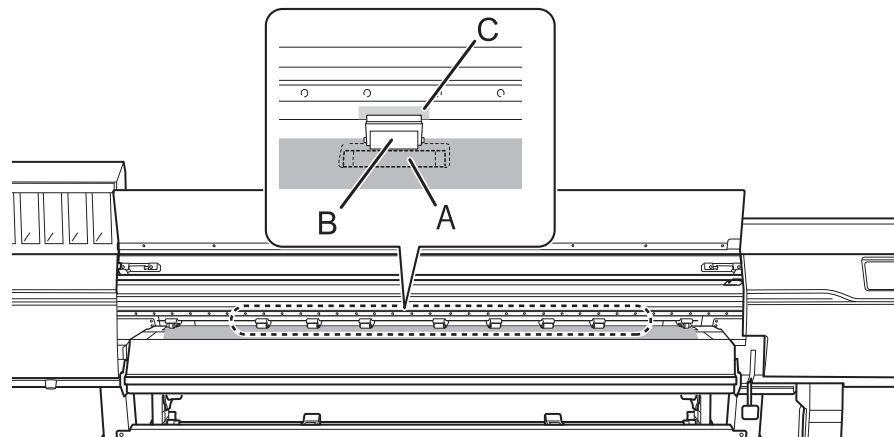

IMPORTANT

- Place the middle pinch rollers over all the grit patterns within the media width. If you have forgotten to place the middle pinch rollers, the media will be skewed during printing or will come loose, which will have an effect on the printing quality.
- The middle pinch roller will not lower onto the three grit rollers from the right end. Place the middle pinch roller on a grit roller other than these three.

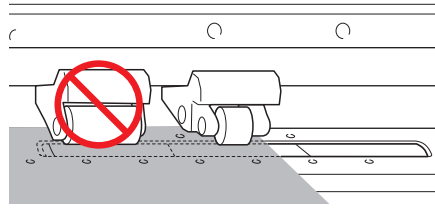

- There may be extra middle pinch rollers depending on the width of the media being used. Move the extra middle pinch rollers to positions where no grit patterns are present. Where no grit patterns are present, the middle pinch rollers will not come down.

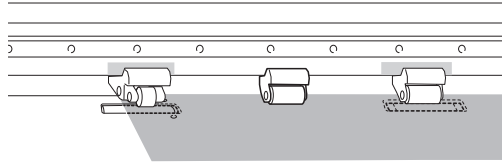

11. Lower the loading lever (front).

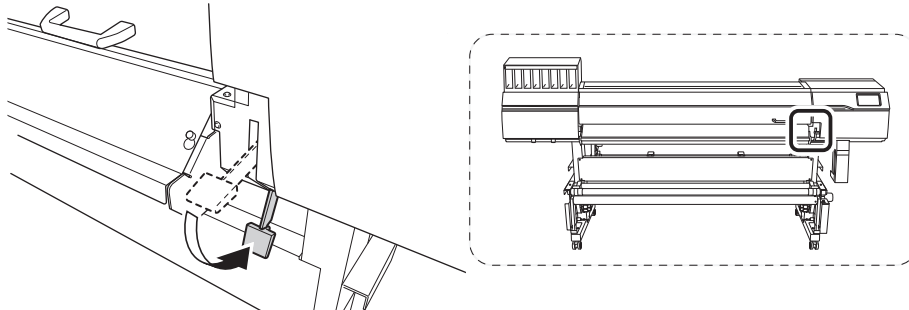

IMPORTANT

If you want to readjust the media position before securing it in place, redo the procedure from step 5.

12. Line up the edges of the media with the centers of the holes of the left and right media clamps.

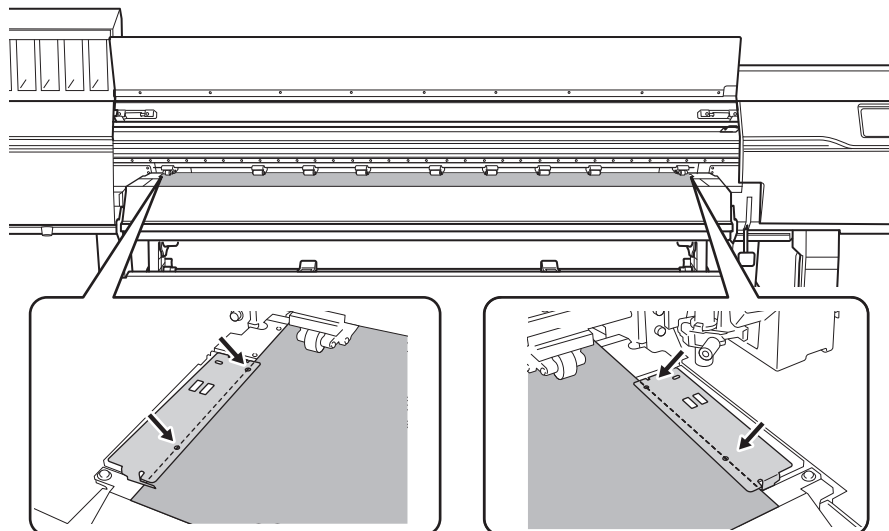

13. Close the front cover.

1. B: Determining the Positions of Media (If [Media Edge Detection]: [Disable])

Use the following procedure to determine the positions of the media when using transparent media, whose edges cannot be detected, and when [Preferences]>[Media Edge Detection] is set to [Disable].

Procedure

1. Tap  on the operation panel.
The sub power is switched on.
2. Open the front cover.
3. Move the media clamps to the outside of the grit rollers on the left and right edges respectively.

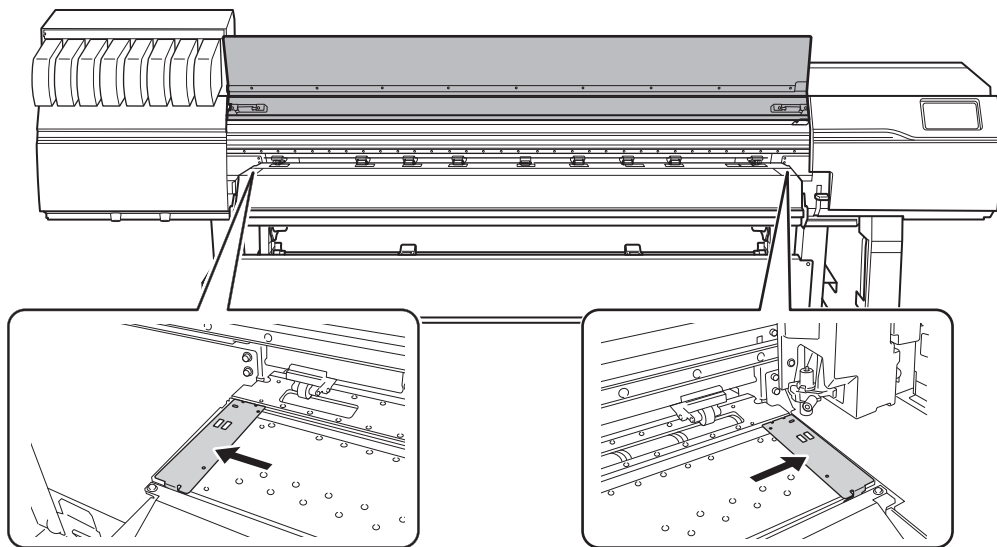

4. Release the locking mechanisms of the media holders, and then draw them to the left and right ends respectively.

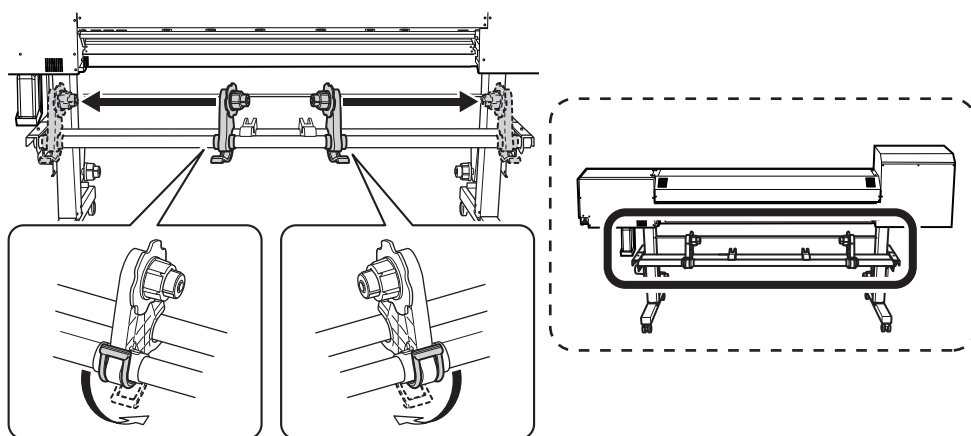

5. Move to the rear of the printer and open the rear UV shield.
 - a. Open the rear UV shield (①).

- b. Push the rear UV shield to the front of the machine, and then place this shield on the left and right stoppers (②).

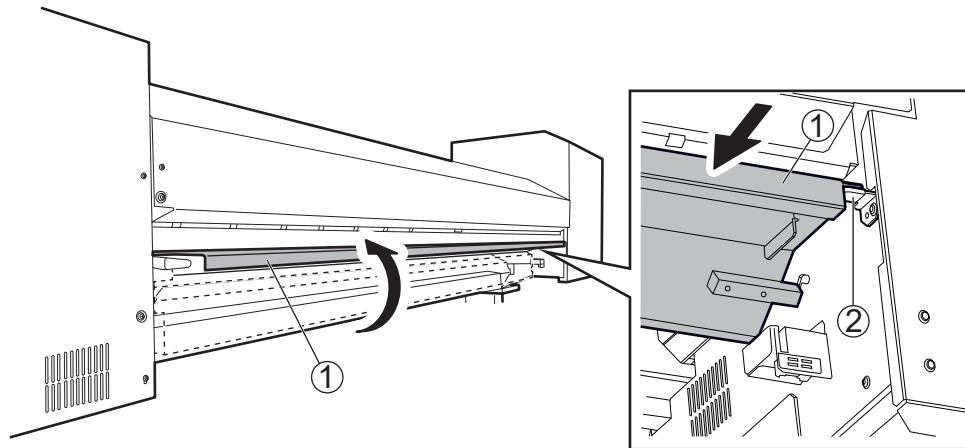

6. Pass the leading edge of the media between the pinch rollers (A) and the grit rollers (B).

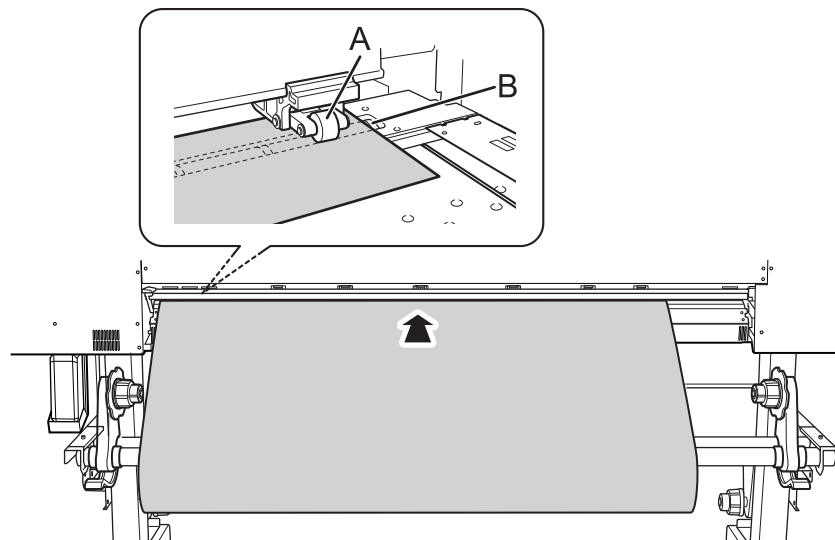

7. Lower the loading lever (rear).
The media is held in place.

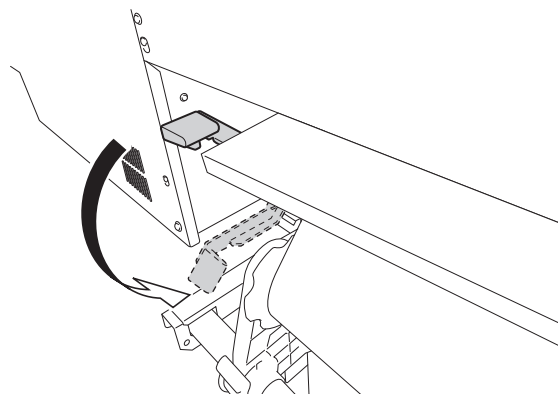

8. Close the rear UV shield.
- Pull the rear UV shield (①) to the back of the machine, and then remove the left and right ends of this shield from the stoppers (②).
 - Close the rear UV shield.

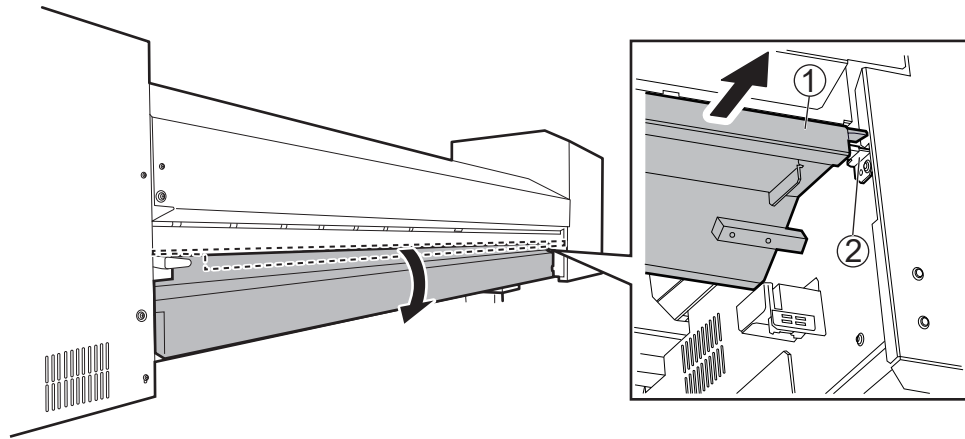

9. (Move to the front of the printer.) Gently hold down the media and raise the loading lever (front). The media is released.

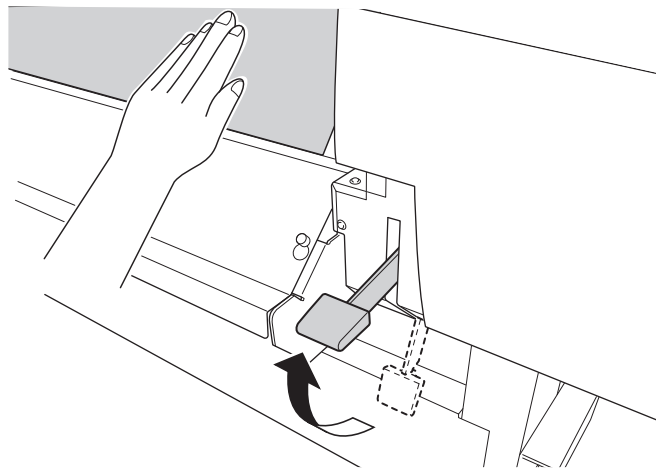

10. Make sure both edges of the media are above the grit rollers. Be sure to place the right edge of the media on the right-end grit roller.

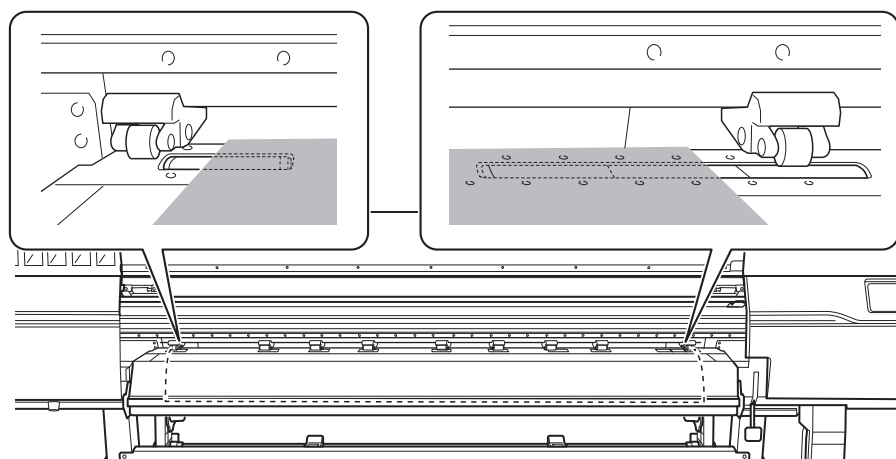

11. Move the left and right pinch rollers, placing them on both edges of the media. Position them approximately 10 mm (0.39 in.) from each edge of the media.

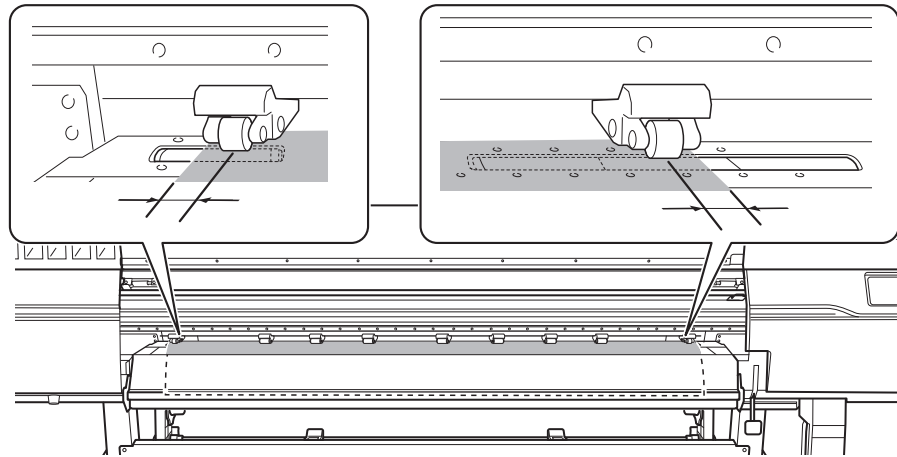
**IMPORTANT**

Be sure to use the left and right pinch rollers. The force with which the media is pinched varies between the middle pinch rollers and the left and right pinch rollers. Using the middle pinch rollers to pinch the media edges will lead to unstable media feeding.

MEMO

To smoothly move the pinch rollers, push down close to the rail.

12. Move the middle pinch rollers (B) over all the remaining grit rollers (A) covered by the media. There are grit patterns (C) wherever there are grit rollers.

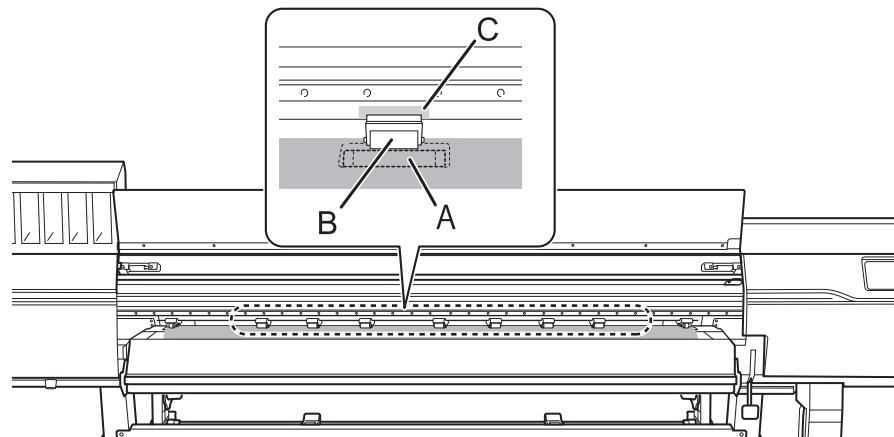
**IMPORTANT**

- Place the middle pinch rollers over all the grit patterns within the media width. If you have forgotten to place the middle pinch rollers, the media will be skewed during printing or will come loose, which will have an effect on the printing quality.
- The middle pinch roller will not lower onto the three grit rollers from the right end. Place the middle pinch roller on a grit roller other than these three.

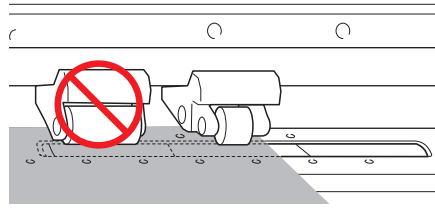

- There may be extra middle pinch rollers depending on the width of the media being used. Move the extra middle pinch rollers to positions where no grit patterns are present. Where no grit patterns are present, the middle pinch rollers will not come down.

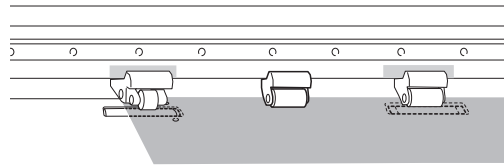

13. Lower the loading lever (front).

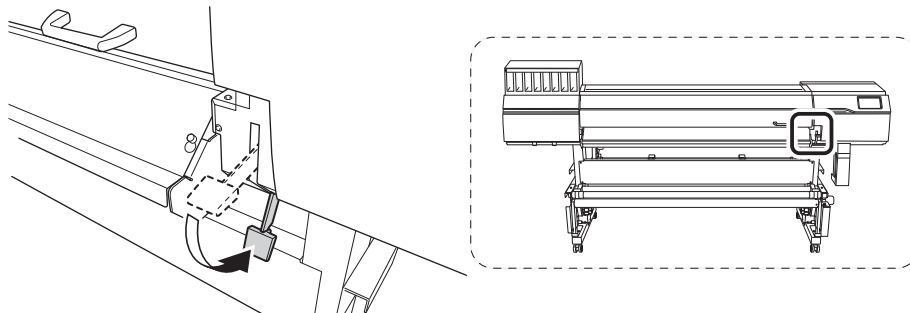

IMPORTANT

If you want to readjust the media position before securing it in place, redo the procedure from step 10.

14. Line up the edges of the media with the centers of the holes of the left and right media clamps.

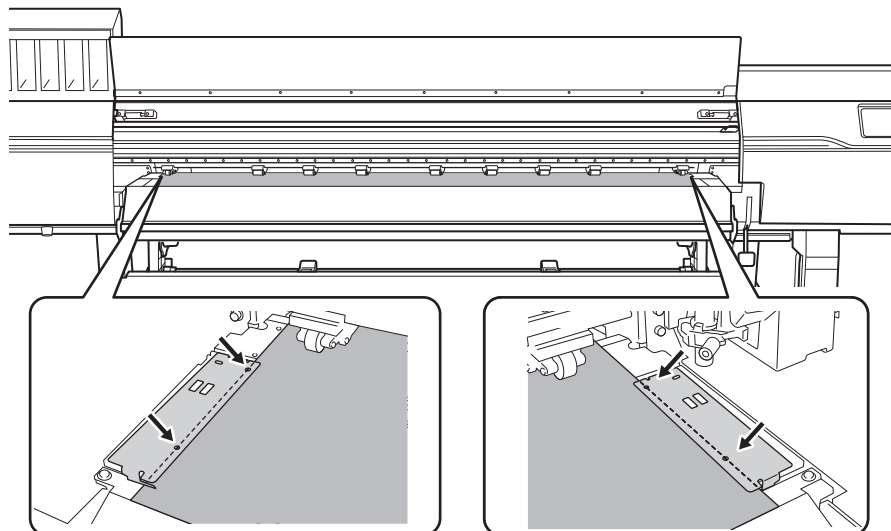

15. Close the front cover.

2. Select the media.

Procedure





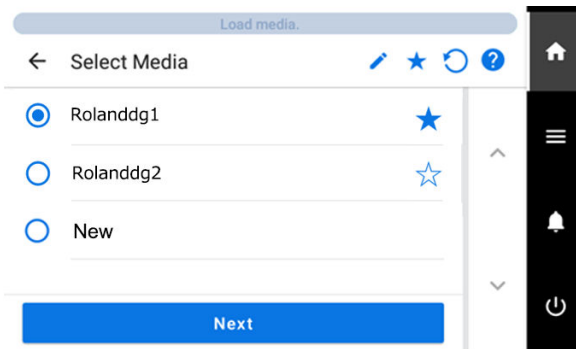



1. Tap  [Setup].

The registered media is displayed in a list.



2. Select the media name to use.

MEMO

- Tapping  makes it possible to search the registered media by keyword.
To reset the entered keyword, tap .
- Tapping  to the right of the media name will change the symbol to , and the media will be registered to Favorites.
Tap the favorites filter () at the top of the operation panel to turn the filter on () and show only favorited media.
Tap  to turn the Favorites filter off.
- Tap  to turn the Favorites filter off () and reset all keywords.
- Keyword searching and the Favorites filter can be used at the same time.



3. Tap [Next].
4. The [Setup Method] screen appears. Select whether to use the take-up unit.
5. Tap [Start Setup].
The cutting carriage moves and detects the width of the media and the positions of the media clamps. This operation is called initialization.
6. When [Printing Area (Width)] screen appears, use the following procedure to configure the settings.

MEMO

The media selected in step 2 is media whose printing area was set manually when registered as new media. The printing area must be set manually each time, so the [Printing Area (Width)] screen appears.

- (1) Tap [Change].

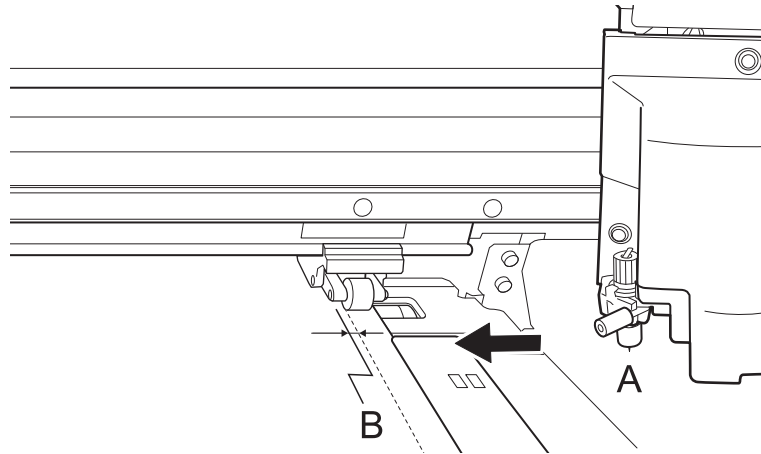

The [Set the right edge of the printing area within the area specified by the pinch rollers.] window appears.

- (2) Hold down  or  to move the center of the blade (A) approximately 2 mm (0.08 in.) to the inside (B) from the left edge of the right pinch roller.



- (3) Tap [OK].

The [Set the left edge of the printing area within the area specified by the pinch rollers.] window appears.

- (4) Hold down  or  to move the center of the blade (A) approximately 2 mm (0.08 in.) to the inside (B) from the right edge of the left pinch roller.

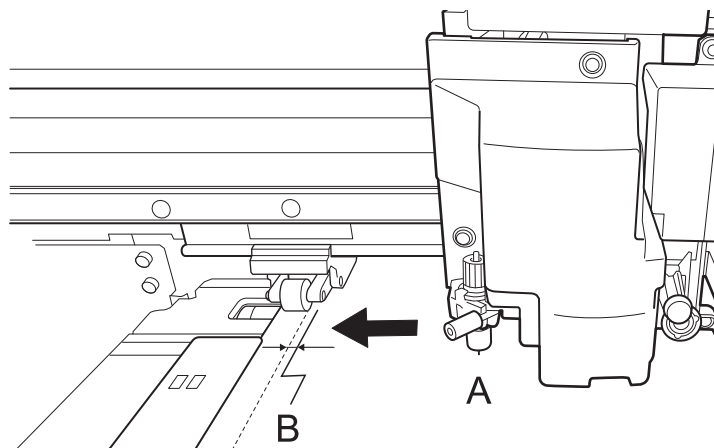

- (5) Tap [OK].

The set left and right positions are applied to the [Printing Area (Width)].

- (6) Tap [OK].

Checking before Output

LAN (Local Area Network) Settings

Check that you can perform communication through the LAN (Local Area Network).

The LAN is enabled if the status LED on the LAN connector located on the side of the printer is lit in green.

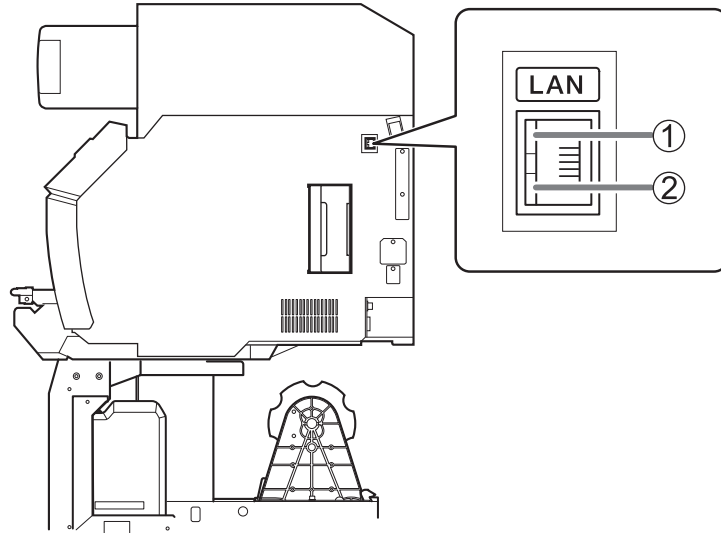

①	Activity LED	This flashes orange while data is being received from the network.
②	Status LED	This indicates the status of the communication function. When it lights in green, communication is possible.

Preventing Sedimentation in Inks

The precipitation of the ingredients in the ink disables printing in normal color. So that the ink mixes well, shake the ink cartridge horizontally with a stroke length of around 5 cm (2 in.) from each end of the ink cartridge.

Shake the ink cartridges:

- All inks: When replaced with a new product.
- White ink: Each day (before starting the day's operations).

Remove the white ink cartridge, shake it 50 times (about 20 seconds), and then reinsert this cartridge.

The ingredients in white ink tend to settle. Each day, before starting the day's operations, be sure to shake this cartridge. Allowing the ink to stand can cause the settled material to harden, resulting in malfunctions or other problems.

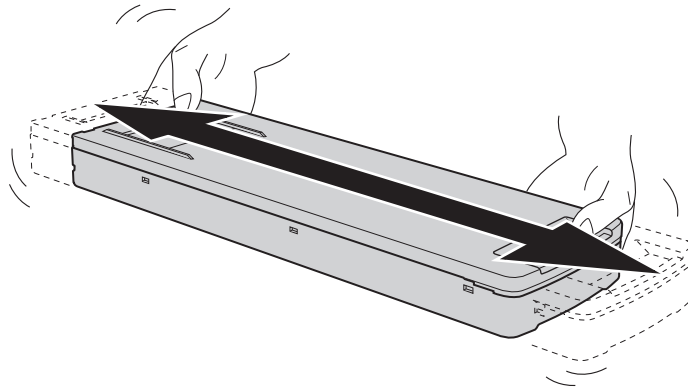

IMPORTANT

- Before shaking the ink cartridge, wipe off any ink from around its mouth. If you do not wipe off the ink, it may splatter when you shake the ink cartridge.
- When you shake the ink cartridge, firmly hold it with both hands to prevent the cover from coming loose. The cover or ink pouch coming loose and falling may cause damage or printer malfunctions.
- When you have finished mixing the ink, reattach the ink cartridge immediately. Taking time to reattach the ink cartridge will adversely affect the ink path.
- Even if you are not using the printer, shake the white ink cartridge 50 times (about 20 seconds) once a week.

Pausing and Canceling Output

You can pause and cancel output before it finishes.

Pausing and Resuming Output

IMPORTANT

We do not recommend resuming printing because horizontal bands are produced at the place where printing was paused.

MEMO

Some menu items can be operated during output, but return to the home screen before pausing output.

Procedure

1. During output, tap [Pause].
This pauses the printing operation.
2. Tap [Resume].

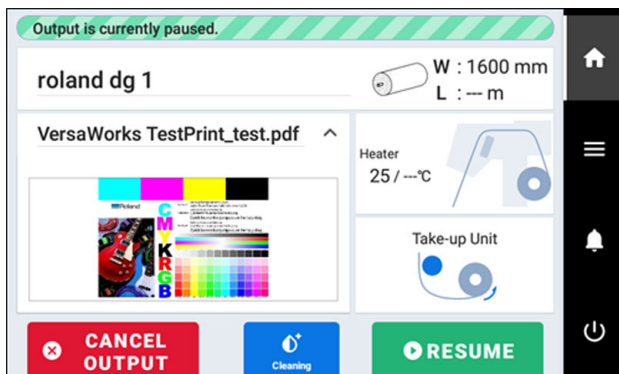

The printing operation resumes.

Canceling Output

Procedure

1. During output, tap [Pause].
This pauses the printing operation.
2. Tap [Cancel Output] when the following screen appears.

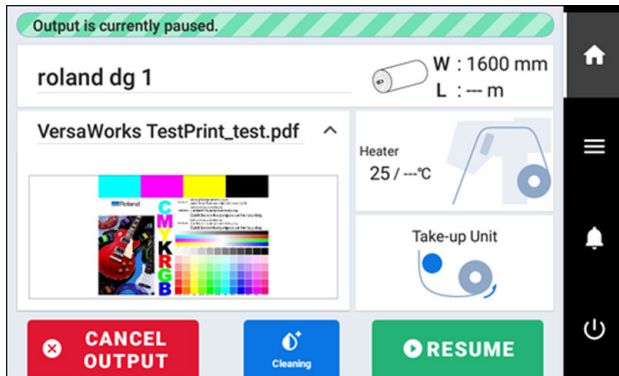

Output is canceled.

3. Stop sending the output data from the computer.

Separating the Media



After printing, use [Sheet Cutting] or [Perforated Sheet Cutting] to separate the media.

Procedure

1. Close the front cover.
2. If necessary, use the following procedure to set the separation position.

(1) Tap .

(2) Tap  [Move].

(3) Tap  or  to set the media to the separation position.

The media is separated at the position in the following figure. Use the media clamp holes as a guideline for this position.

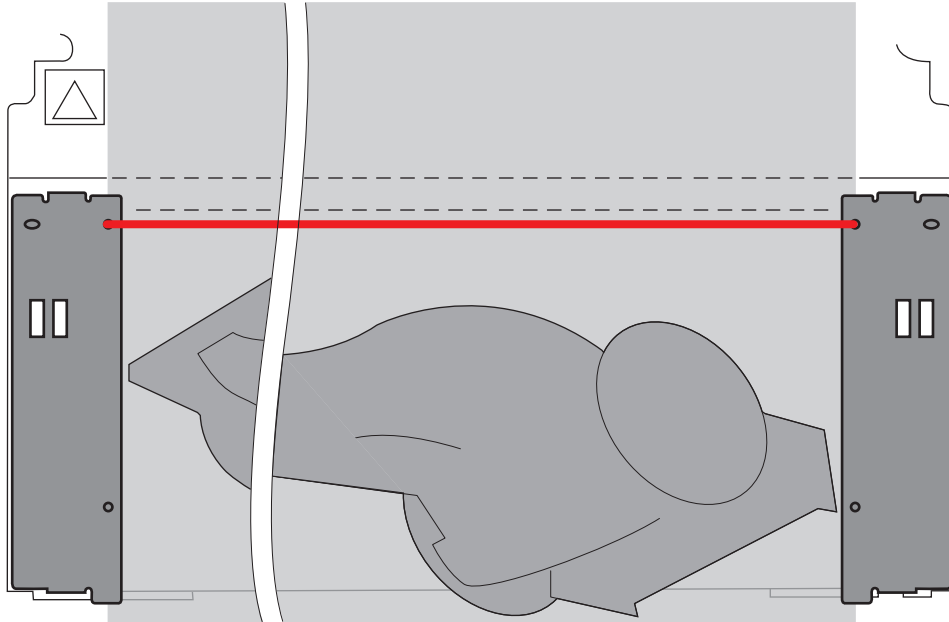

(4) Tap [Set Base Point Here].

The separation position is set, and you are returned to the home screen.

3. Tap  [Sheet Cutting] on the operation panel.

4. Select the sheet cutting method.

[Sheet Cutting]	This separates the media.
[Perforated Sheet Cutting]	The media is perforated without being separated.

MEMO

If the media is separated even after you select **[Perforated Sheet Cutting]**, use **[Preferences]>[Perforated Sheet Cutting]** to change to the **[Increase Uncut Locations]** setting. If the media is heavy or has a large amount that is slack, it can be retained without being separated.

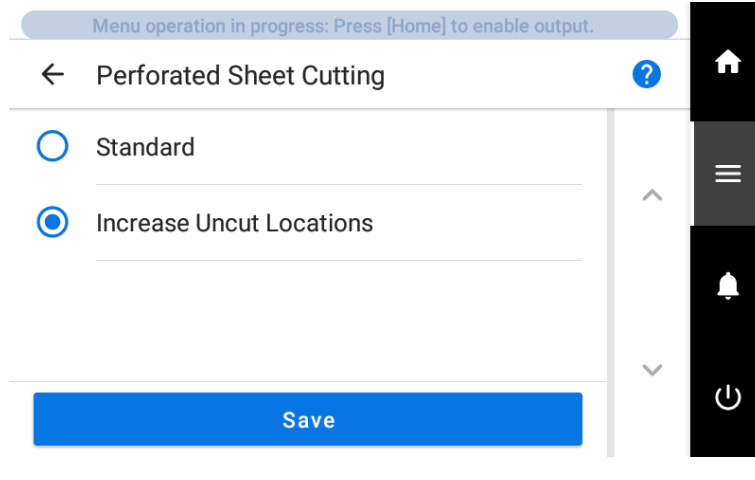

5. Tap **[Execute]**.

The media is separated. If **[Perforated Sheet Cutting]** was selected in step 4, the media is perforated.

- You can configure settings in the software RIP for automatic media separation after output has finished. For information on how to configure the settings, refer to the documentation for the software RIP you are using.
- When using a take-up unit, take-up may be interrupted by media separation, so we recommend you turn off the automatic separation function or insert perforated sheet cutting with the included software RIP to ensure the media is not separated.

IMPORTANT

Separation Operations

- If the distance from the end of the media to the separation location is short, separation may not be performed smoothly.

When Using a Take-up Unit

- Do not operate the manual switch on the take-up unit leaving the loading lever lowered. Tension is applied to the media by the take-up unit, so avoid operations that pull the media with excessive force.

Give Attention to the Media Composition

- For some types of media, separation is not possible.
- Some types of media may remain on the platen after separation. If the media remains on the platen, remove it by hand.

Removing Media from the Take-up Unit

When output is complete, separate the media, take up the media manually, and then remove the media.

⚠ WARNING

Handling roll media is an operation that must be performed by 2 persons or more, and care must be taken to prevent falls.

Attempting to lift heavy media in a manner that taxes your strength may cause physical injury. Also, if dropped, such items may cause injury.

Procedure

1. Lower the dancer roller toward the rear.

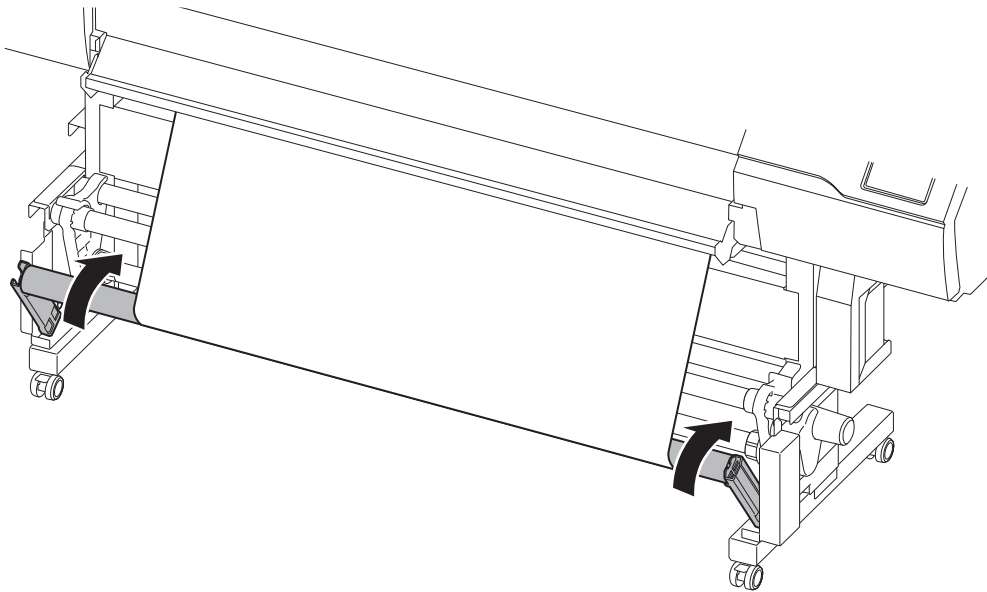

2. Close the front cover.

3. With the media held down, tap  [Sheet Cutting] on the operation panel.

4. Select [Sheet Cutting] and tap [Execute].

IMPORTANT

Give Attention to the Media Composition

- For some types of media, separation is not possible.
- Some types of media may remain on the platen after separation. If the media remains on the platen, remove it by hand.

5. Use the MANUAL switch to take-up the media.

Removing Media from the Take-up Unit

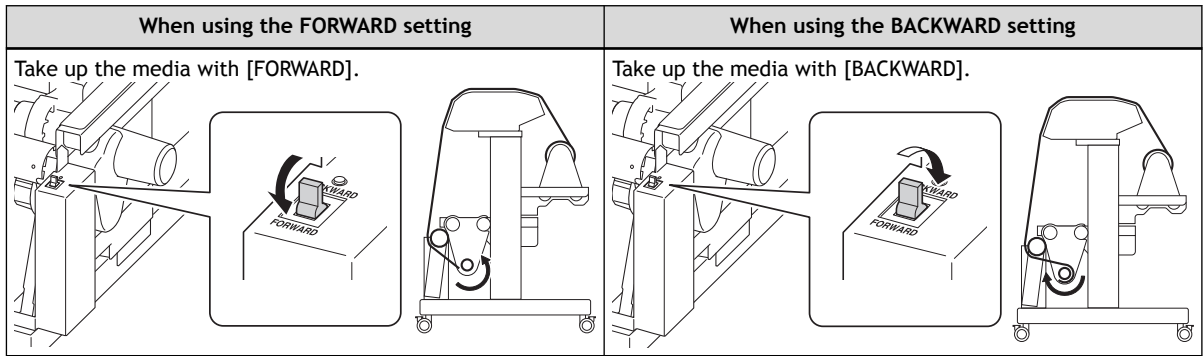

6. While supporting the media from below, loosen the securing lever on the left media holder.

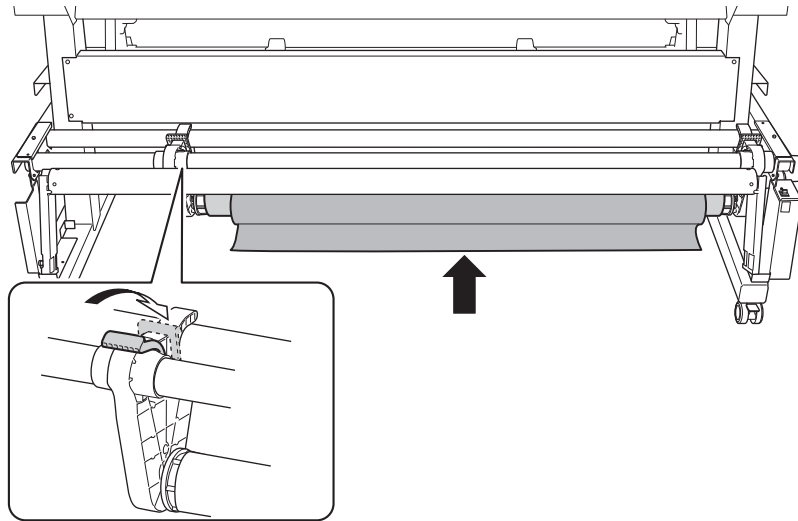

7. With the media supported, pull the paper tube and media from the end cap.

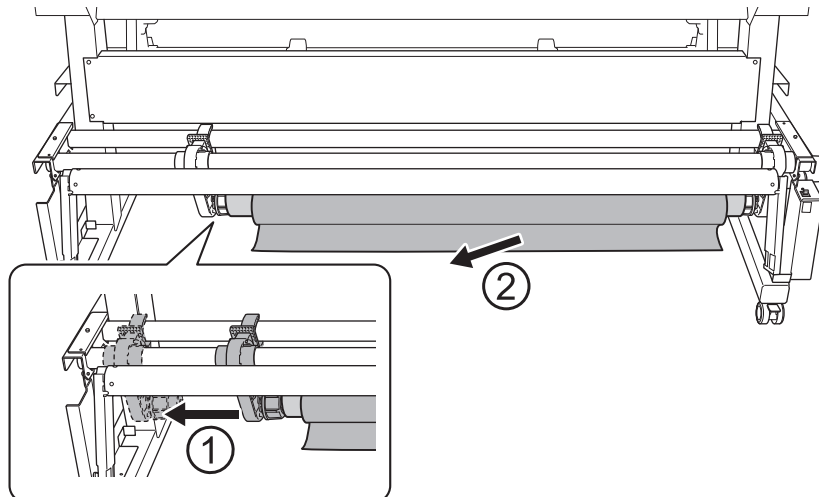

Replacing Ink

Out-of-ink Warnings

When an ink cartridge runs out of ink, an [Ink Cartridge Error] appears.

[Empty] is displayed for ink that has run out. Check the display screen, and then replace the empty ink.

IMPORTANT

- If ink runs out during printing, printing is paused.
- If ink runs out during cleaning, cleaning is canceled.

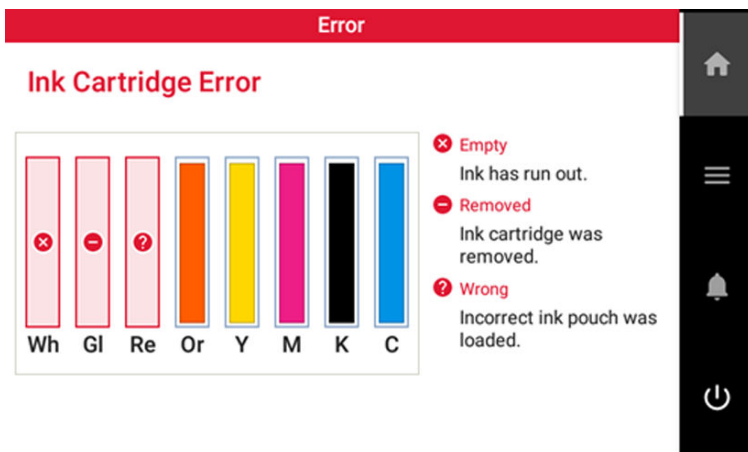

IMPORTANT

Never reuse an ink pouch within an ink cartridge for which the machine shows a sign indicating no ink.

Occasionally the machine will show a sign indicating no ink even if there is a small amount of ink remaining in the pouch, but nevertheless do not use it. Such an ink pouch is in a state where drawing ink from it is impossible. Using it in such a state may force air into the ink path and cause printer malfunctions.

RELATED LINKS

- [P. 114 Ink Replacement Method](#)

Ink Replacement Method

⚠ WARNING

Never store ink, cleaning liquid, or discharged fluid in any of the following locations.

- Any location exposed to open flame
- Any location where high temperature may occur
- Near bleach or any other such oxidizing agent or explosive material
- Any location within the reach of children

Fire may be a danger. Accidental ingestion by children may pose a health hazard.

IMPORTANT

Precautions regarding ink pouch replacement

- Be sure to replace each pouch with an item of identical type and color.
- Never use an ink pouch that has already been used in another machine even if it is an identical type.
- Never mix different types of items.
- Never leave the machine with an ink cartridge removed. The print heads may become clogged.
- Do not remove or insert ink cartridges during printing, cleaning, or ink circulation. Ink may leak.
- If the cover of an ink cartridge does not lock securely, this cartridge needs to be replaced.

For information about purchasing ink cartridges, contact your authorized dealer or visit our website (<https://www.rolanddg.com/>).

IMPORTANT

Never reuse an ink pouch within an ink cartridge for which the machine shows a sign indicating no ink.

Occasionally the machine will show a sign indicating no ink even if there is a small amount of ink remaining in the pouch, but nevertheless do not use it. Such an ink pouch is in a state where drawing ink from it is impossible. Using it in such a state may force air into the ink path and cause printer malfunctions.

Procedure

1. Pull out from the machine the ink cartridge of the color to replace.

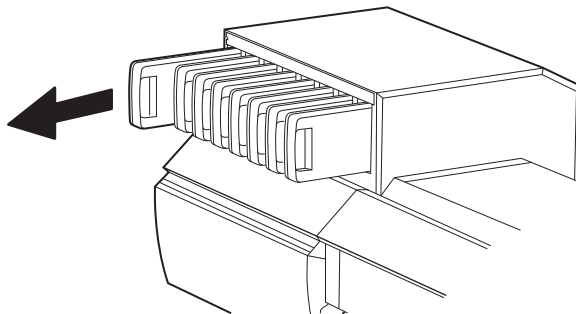

2. Remove the cover of the cartridge.
 - a. Keep the side with the arrow mark face up.
 - b. Remove the cover by sliding it in the direction indicated by the arrow.

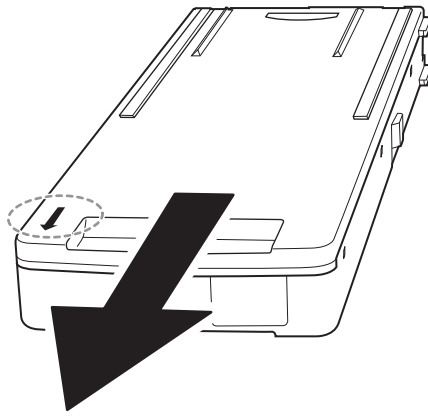

3. Remove the used ink pouch from the cartridge case.

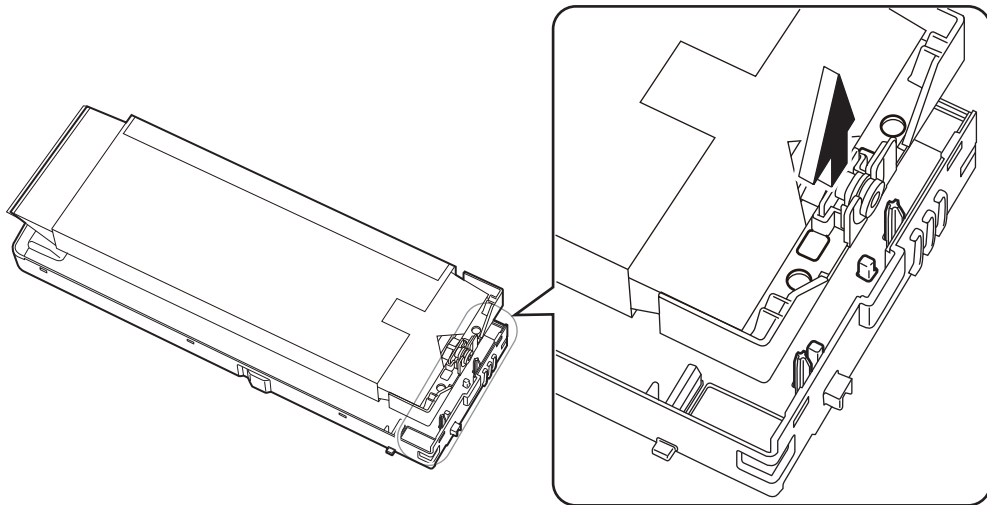

4. Load a new ink pouch in the cartridge case.

MEMO

Pass the protrusions on the cartridge case through the holes on the ink pouch to load it in the correct position.

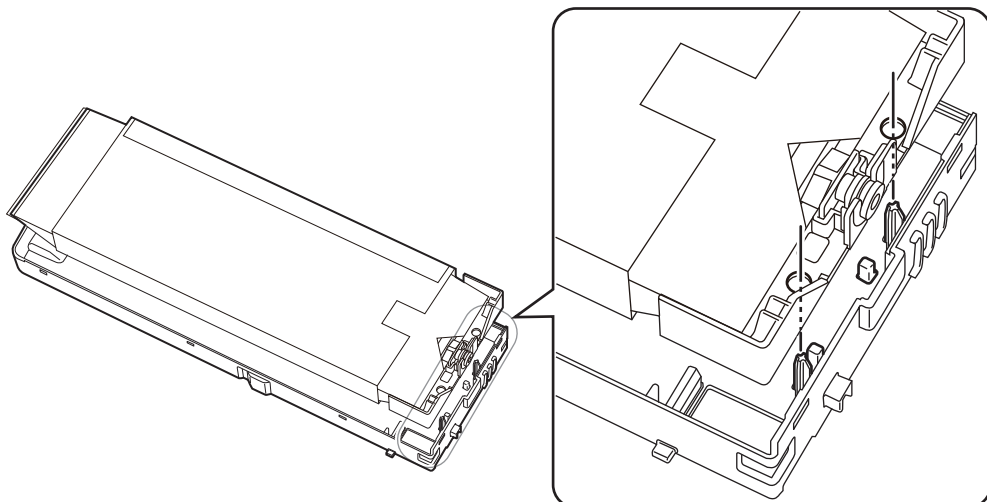

5. Attach the cover to the cartridge case.
 - a. Insert the protrusions (A) at the back of the cover into the holes in the cartridge case.

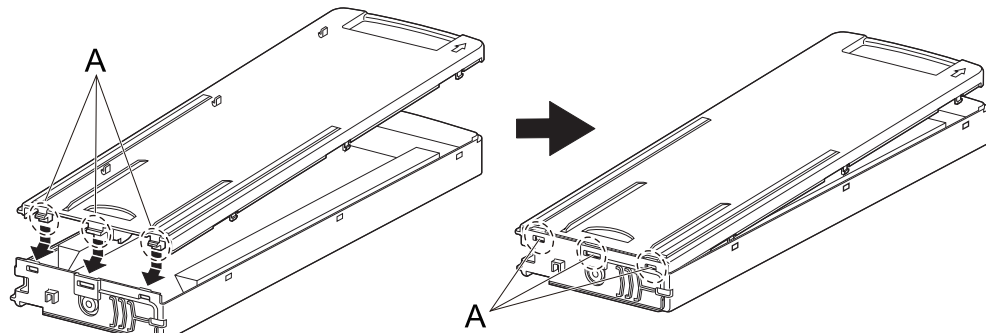

- b. Push the cover to fit its hooks into the holes in the cartridge case.

There are hooks in six locations. Check that all the hooks are seated in the holes and that the cover does not come loose from the cartridge case.

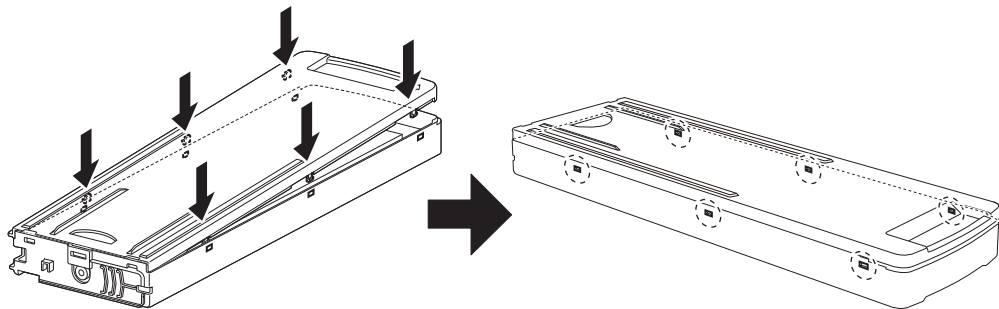

6. Gently shake the ink cartridge.

Shake the ink cartridge 50 times (for approximately 20 seconds) horizontally with a stroke length of 5 cm (1.97 in.) from each end of the cartridge.

IMPORTANT

When you shake the ink cartridge, firmly hold it with both hands to prevent the cover from coming loose. The cover or ink pouch coming loose and falling may cause damage or printer malfunctions.

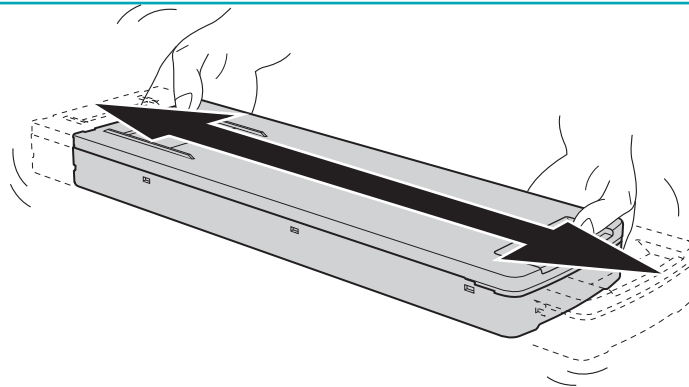

7. Load the ink cartridge in its ink slot.

Orient the cartridge so its protrusion (①) is face up, and then, while keeping the cartridge level, insert the cartridge as far as it will go.

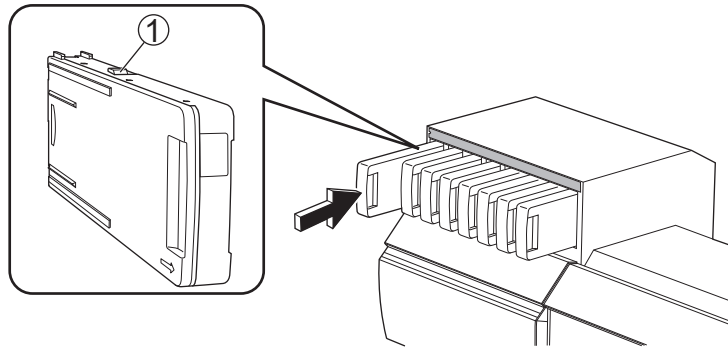
**IMPORTANT**

- If an ink cartridge contains an empty ink pouch, do not insert this cartridge into its ink slot. Doing so may force air into the ink path and cause printer malfunctions.
- Check the color names indicated on the ink slots and the ink cartridges to load these cartridges in their correct positions.

Preventing Sedimentation in Inks

The precipitation of the ingredients in the ink disables printing in normal color. So that the ink mixes well, shake the ink cartridge horizontally with a stroke length of around 5 cm (2 in.) from each end of the ink cartridge.

Shake the ink cartridges:

- All inks: When replaced with a new product.
- White ink: Each day (before starting the day's operations).

Remove the white ink cartridge, shake it 50 times (about 20 seconds), and then reinsert this cartridge.

The ingredients in white ink tend to settle. Each day, before starting the day's operations, be sure to shake this cartridge. Allowing the ink to stand can cause the settled material to harden, resulting in malfunctions or other problems.

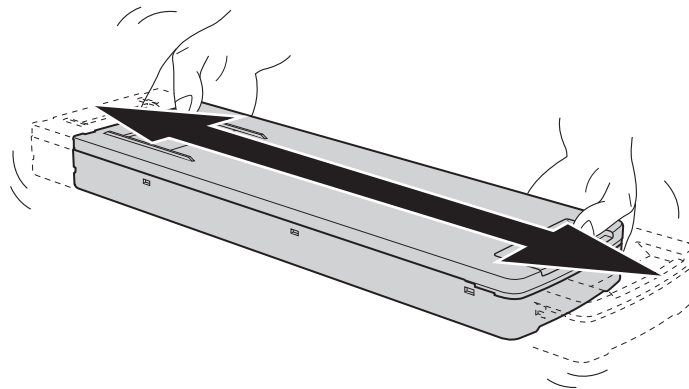

IMPORTANT

- Before shaking the ink cartridge, wipe off any ink from around its mouth. If you do not wipe off the ink, it may splatter when you shake the ink cartridge.
- When you shake the ink cartridge, firmly hold it with both hands to prevent the cover from coming loose. The cover or ink pouch coming loose and falling may cause damage or printer malfunctions.
- When you have finished mixing the ink, reattach the ink cartridge immediately. Taking time to reattach the ink cartridge will adversely affect the ink path.
- Even if you are not using the printer, shake the white ink cartridge 50 times (about 20 seconds) once a week.

Replacing the Cleaning Liquid

Out-of-cleaning-liquid Warnings

If the cleaning liquid runs out, [Replace the cleaning liquid pouch.] appears on the screen. Tap [OK] to close this message.

You can also check the message by tapping

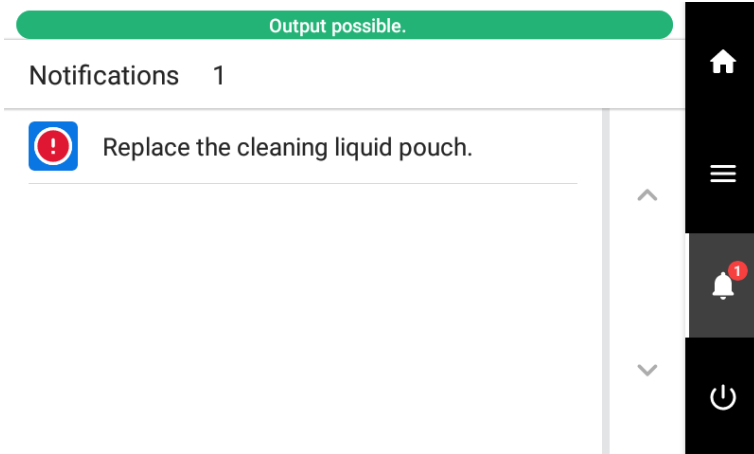

RELATED LINKS

- [P. 120 Cleaning Liquid Replacement Method](#)

Cleaning Liquid Replacement Method

⚠ WARNING

Never store ink, cleaning liquid, or discharged fluid in any of the following locations.

- Any location exposed to open flame
- Any location where high temperature may occur
- Near bleach or any other such oxidizing agent or explosive material
- Any location within the reach of children

Fire may be a danger. Accidental ingestion by children may pose a health hazard.

IMPORTANT

Precautions regarding cleaning liquid pouch replacement

- Never insert or remove the cleaning cartridge with undue force. Cleaning liquid may leak.
- If the cover of the cleaning cartridge does not lock securely, this cartridge needs to be replaced.

For information about purchasing cleaning cartridges, contact your authorized dealer or visit our website (<https://www.rolanddg.com/>).

Procedure

1. Pull out the cleaning cartridge from the machine.

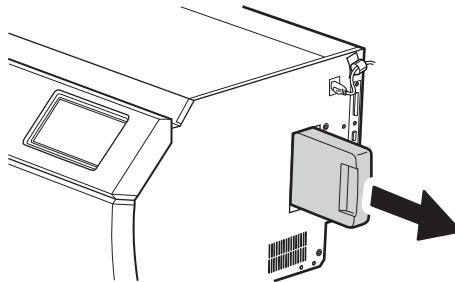

2. Remove the cover of the cartridge.
 - a. Keep the side with the arrow mark face up.
 - b. Remove the cover by sliding it in the direction indicated by the arrow.

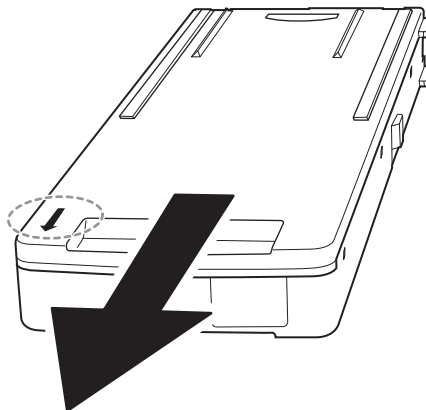

3. Remove the used cleaning liquid pouch from the cartridge case.

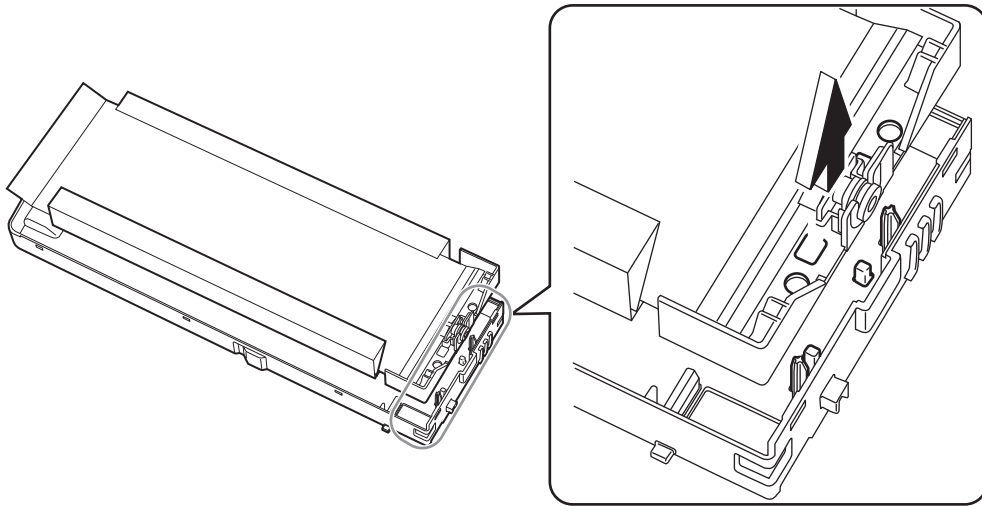

4. Load a new cleaning liquid pouch in the cartridge case.

MEMO

Pass the protrusions on the cartridge case through the holes on the cleaning liquid pouch to load it in the correct position.

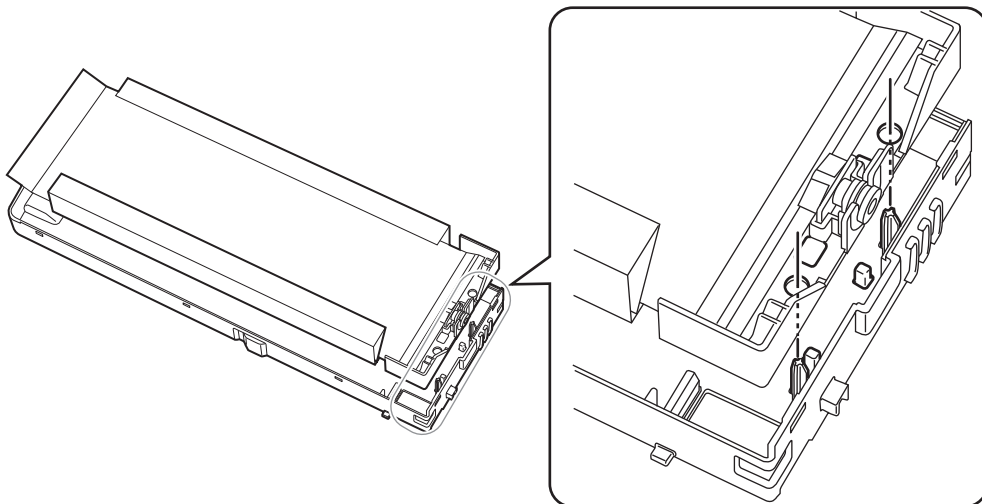

5. Attach the cover to the cartridge case.

- a. Insert the protrusions at the back of the cover (A) into the holes on the cartridge case.

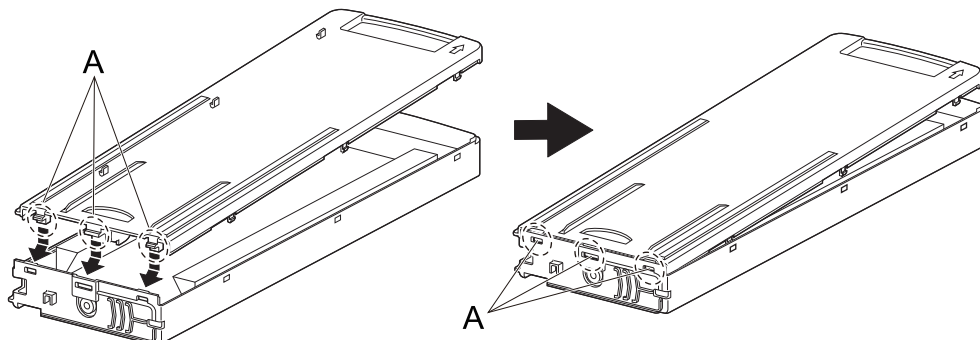

- b. Press down on the cover to fit the cover hooks into the holes on the cartridge case.

Replacing the Cleaning Liquid

There are six hooks. Check that all the hooks have been fit into the holes and that the cover does not come free from the cartridge case.

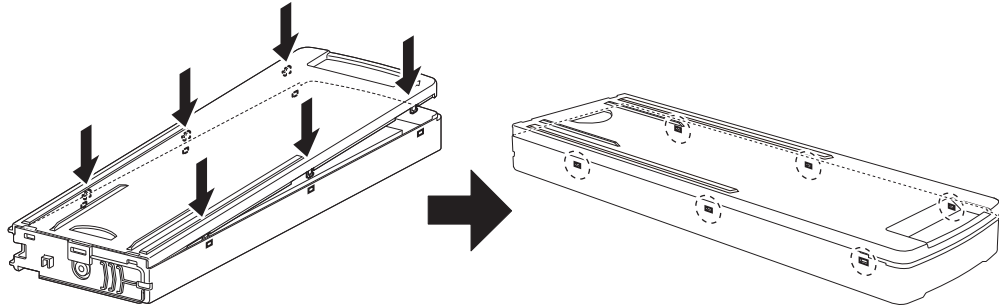

6. Load the cleaning cartridge in the cleaning liquid slot.

Orient the cartridge so its protrusion (①) is face up, and then, while keeping the cartridge level, insert the cartridge as far as it will go.

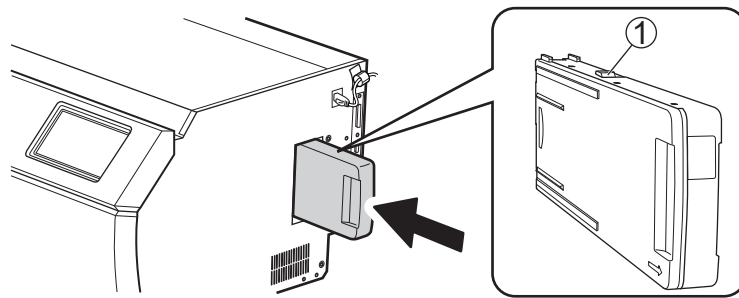

7. Tap [Yes] when the cleaning liquid pouch replacement confirmation screen appears.

If you tap [Yes] to reset the amount of cleaning liquid remaining, the cleaning liquid pouch will be identified as a new product.

MEMO

If you tap [Yes] on the cleaning liquid pouch replacement confirmation screen even though you have not replaced the cleaning liquid pouch, the amount of cleaning liquid remaining is reset. In this situation, no notification will appear even if the amount of cleaning liquid remaining is very small, and the message [Replace the cleaning liquid pouch.] will appear when the cleaning liquid runs out. To ensure you have enough time to prepare the replacement cleaning liquid, tap [No] if you have not replaced the cleaning liquid.

Output Method

Preparations for Output and Output Methods

Preparations before Daily Operations	125
Checking the Daily Workflow	125
Manual Cleaning Method	126
Printing Method	132
Preparations for Printing Output.....	132
Starting Output	136
Cutting Method	138
Preparations for Cutting Output	138
Starting Output	142
Printing and Cutting Method	143
Preparations for Printing and Cutting Output.....	143
Starting Output	150
How to Cut with Crop Marks	152
Preparations for Output with Crop Marks	152
Starting Output with Crop Marks.....	159
Preparations for Cutting Output	161
Starting Cutting Output	164

Preparations before Daily Operations

Checking the Daily Workflow

This section explains the basic workflow of daily operations.

Performing appropriate maintenance at the correct times can help prevent malfunction as well as bring out the full potential of this machine.

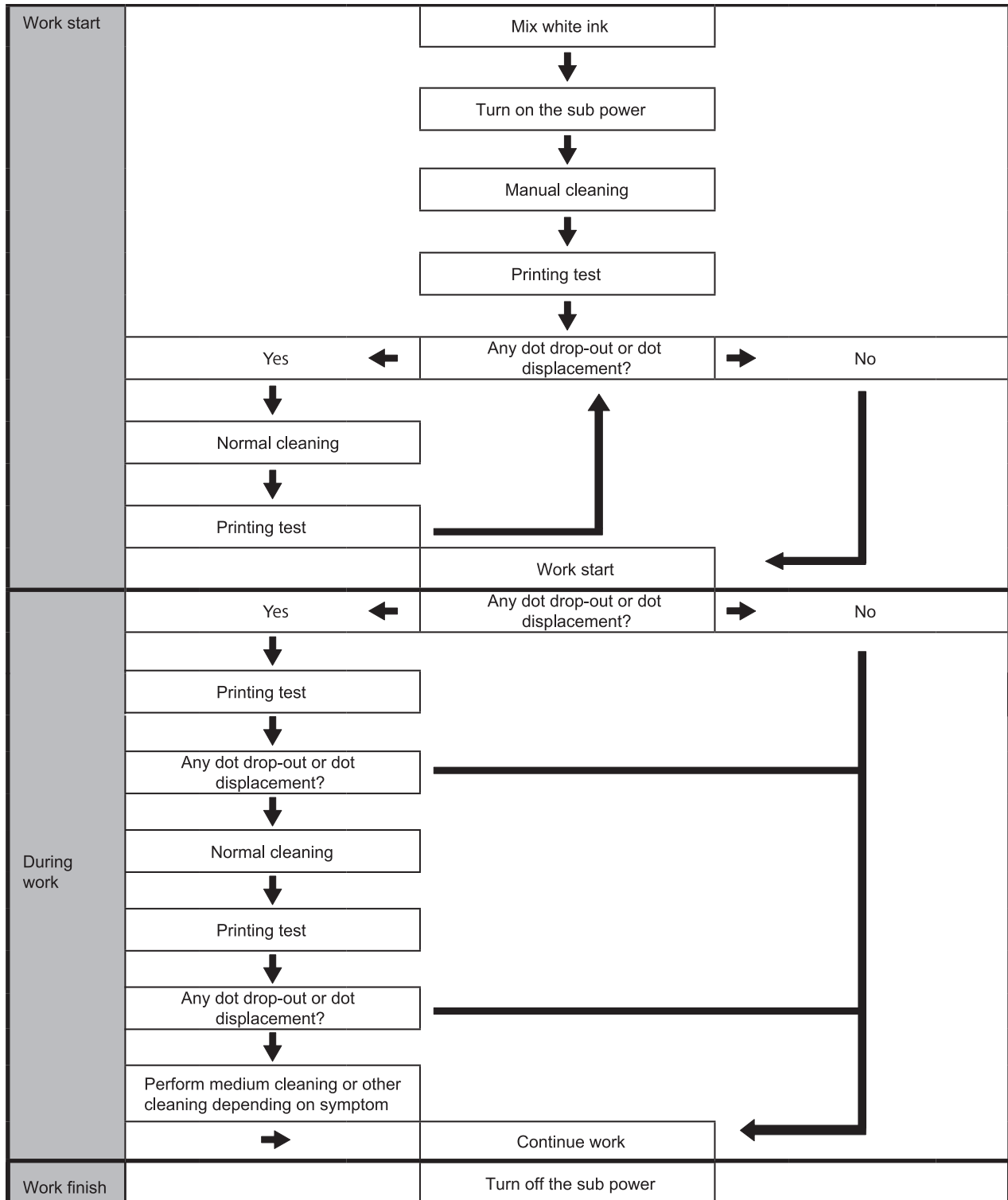

Manual Cleaning Method

Perform manual cleaning:

- Before daily operations
- When the notification [The time for manual cleaning has arrived.] appears.
- Before sending the print data if you want to perform unmanned printing at night.
- When dot drop-out or ink drip issues that cannot be improved with powerful cleaning occur.

⚠ CAUTION

Do not perform cleaning immediately after printing has finished. (Wait approximately 15 minutes after printing finishes.)

The area around the UV-LED device is hot and may cause burns.

⚠ WARNING

Be sure to perform operations as specified by the instructions, and never touch any area not specified in the instructions.

Sudden movement of the machine may cause injury.



IMPORTANT

Important notes on this procedure

- Before attempting this operation, remove any media.
- To prevent the print heads from drying out, finish this procedure in 10 minutes or less. A warning beep sounds after 10 minutes.
- Never use any implements other than the included cleaning sticks. Cotton swabs or other lint-producing items may damage the print heads.
- Do not use cleaning liquid other than the included cleaning liquid.
- Be sure to use new cleaning sticks. Reusing cleaning sticks will adversely affect the printing results.
- Do not put a cleaning stick that has been used for cleaning into the cleaning liquid. Doing so will deteriorate the cleaning liquid.
- Never rub the print head surface (nozzle surface).
- If you use up the cleaning sticks or cleaning liquid, contact your authorized dealer or visit our website (<https://www.rolanddg.com/>).

When an alarm sounds during cleaning

- A warning beep sounds 10 minutes after operation starts. Stop work, close all the covers, and then tap [Finish All] to end the manual cleaning mode. After that, restart the procedure from the beginning.

Required items	
	
Cleaning sticks	Cleaning liquid

1. Clean the print head caps.

Procedure

1. Remove any media.



2. Tap .

3. Tap [Manual Cleaning].

4. Tap [Execute].

The print heads move to the left end of the machine.

5. Follow the instructions on the operation panel to perform [Manual Cleaning].

- Tap  or  to check the procedure.
- If you complete the work without viewing the instructions, tap [Finish All].

IMPORTANT

- Be sure to use one of the included cleaning sticks.
- Do not use a previously used cleaning stick.
- Do not put a previously used cleaning stick into the cleaning liquid.



IMPORTANT

Use a pair of tweezers to remove the pieces of hardened ink that are 3 mm (0.12 in.) or more in length. Do not use excessive force when pulling on pieces of hardened ink that are difficult to remove. Doing so may damage the print head caps.

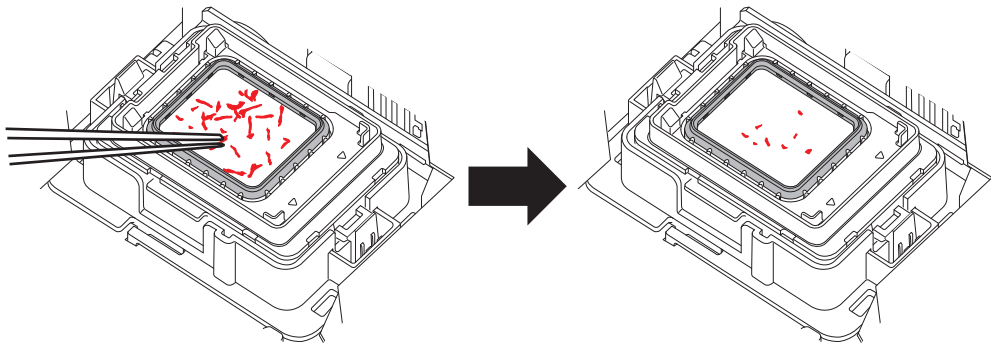

When you have finished cleaning, close the right cover.

2. Clean the print heads.

Procedure

1. Open the left cover.

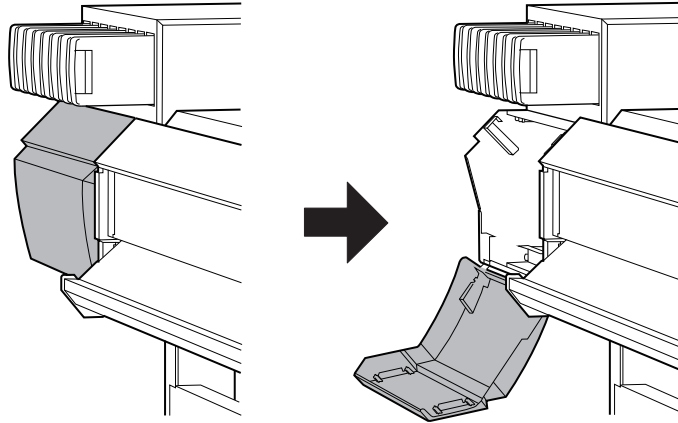

2. Moisten a new cleaning stick with the cleaning liquid.

IMPORTANT

- Be sure to use one of the included cleaning sticks.
- Do not use a previously used cleaning stick.
- Do not put a previously used cleaning stick into the cleaning liquid.



3. Clean the locations shown in the following figure.
Be especially careful to clean away any fibrous dust (lint).

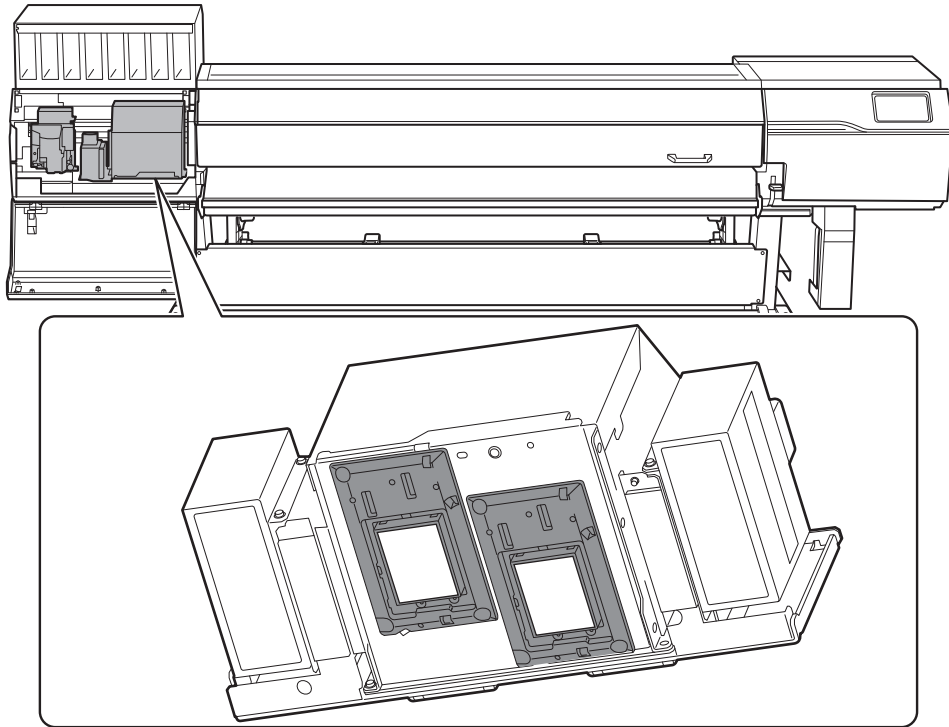

- (1) Press the wide surface of the cleaning stick against the left side and wipe it off. Then, press the opposite surface (which is clean) against the right side and wipe it off.

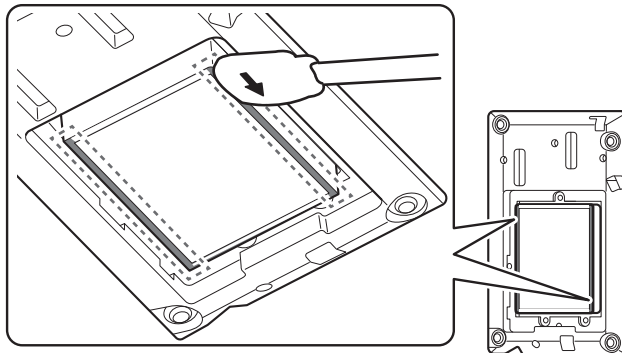

- (2) Stand the cleaning stick upright and wipe off all sides.

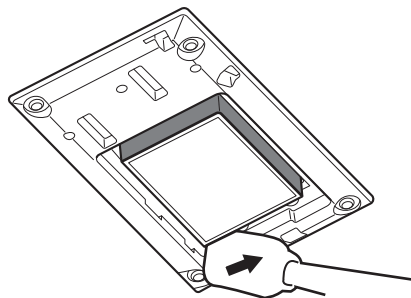

- (3) Use the wide surface of the cleaning stick to wipe away any dirt from the area shown in the figure. If this area has any ink or cleaning liquid that appears likely to drip, use a dry cloth that is not fluffy to gently wipe away the ink or cleaning liquid.

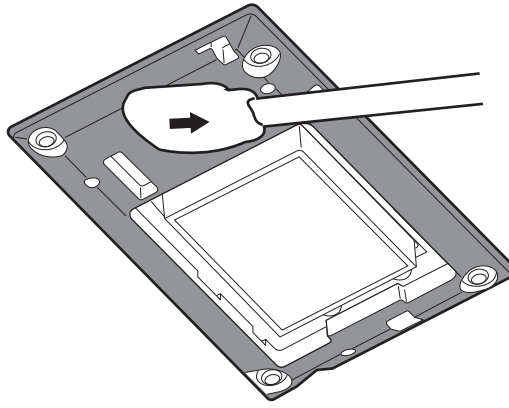

4. Close the left cover.

5. Tap [Finish All].

[Normal cleaning in progress.] is displayed at the top of the screen, and cleaning starts. The (approximate) remaining time for the procedure is displayed on the screen.

6. Tap  to go back to the original screen.

3. Perform a printing test to check the results.

Procedure

1. Set up the media.
P. 31 Setup of New Media
2. Tap  [Nozzle Drop-out Test] on the home screen.
3. Tap [Execute] next to [Printing Test].
Printing of the test pattern starts.

MEMO

Depending on the color of the media used, it may be difficult to check the white ink test pattern.

Tap  [Nozzle Drop-out Test] on the home screen, and then select [Cleaning]>[Printing Test]>[Nozzle Drop-out Test (Base: Black)] to make the base of the white ink black, making it easier to check the white ink. [Nozzle Drop-out Test (Base: Black)] is not displayed if the machine is not equipped with white ink.

4. Check whether there is dot drop-out or dot displacement in the test pattern.
Missing blocks indicate dot drop-out. Collapsed or inclined blocks indicate dot displacement.

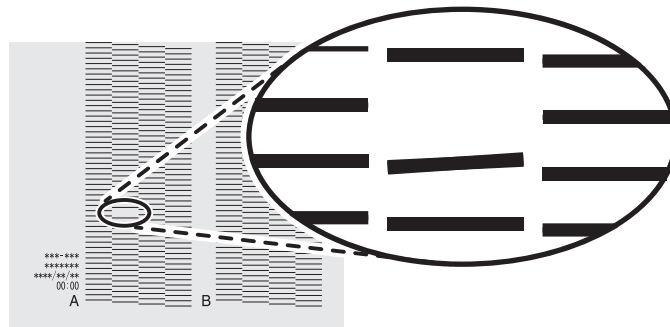

5. If you have opened the front cover, close it.

If no dot drop-out or dot displacement occurs, this operation is finished. Tap  to go back to the original screen.

If dot drop-out or dot displacement is present, perform cleaning such as normal cleaning.

RELATED LINKS

- P. 265 When Dot Drop-out or Dot Displacement Occurs

Printing Method

Preparations for Printing Output

Step 1: Performing a Nozzle Drop-out Test

Before you carry out actual printing, perform a printing test to ensure no dot drop-out or dot displacement occurs. If dot drop-out or dot displacement occurs, perform cleaning of the print heads (normal cleaning).

MEMO

When performing printing tests successively, you can select **[Feed]** (vertical printing) or **[Scan]** (horizontal printing) as the printing position for the second and later tests in comparison to the first test.

[P. 222 Performing Printing Tests Arranged Horizontally](#)

Procedure

1. Set up the media.
2. Tap  **[Nozzle Drop-out Test]** on the home screen.
3. Tap **[Execute]** next to **[Printing Test]**.
Printing of the test pattern starts.

MEMO

Depending on the color of the media used, it may be difficult to check the white ink test pattern.

Tap  **[Nozzle Drop-out Test]** on the home screen, and then select **[Cleaning]>[Printing Test]>[Nozzle Drop-out Test (Base: Black)]** to make the base of the white ink black, making it easier to check the white ink. **[Nozzle Drop-out Test (Base: Black)]** is not displayed if the machine is not equipped with white ink.

4. Check whether there is dot drop-out or dot displacement in the test pattern.
Missing blocks indicate dot drop-out. Collapsed or inclined blocks indicate dot displacement.

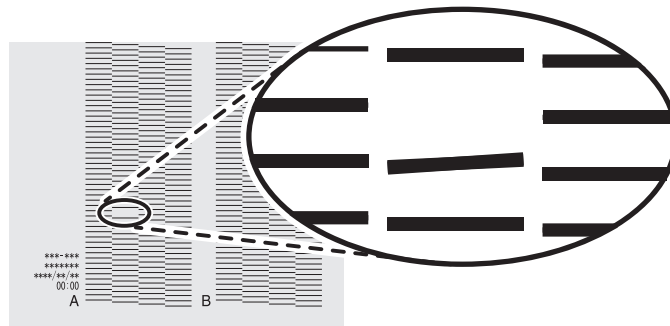

5. If you have opened the front cover, close it.
If no dot drop-out or dot displacement occurs, preparations for output are finished.

RELATED LINKS

- [P. 265 When Dot Drop-out or Dot Displacement Occurs](#)

Step 2: Normal Cleaning Method

MEMO

If the media has already been set up, the [After cleaning, perform a printing test.] menu appears on the [Normal Cleaning] screen. When this setting is turned on, a printing test is performed after cleaning.

Procedure

1. Check for the group with dot drop-out or dot displacement by viewing the results of the printing test. The space from "A" to "B" is group A. The space from "B" to the right side is group B.

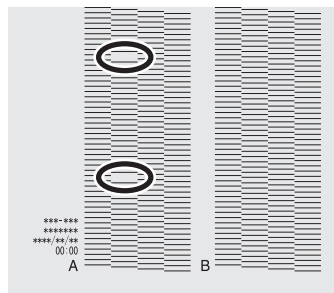

MEMO

If the printing-test results are difficult to interpret, check the results in a bright location, changing your line of vision. They are visible using the reflection of the light.

2. Tap [Cleaning].
3. Tap [Normal Cleaning].
The screen shown below appears.

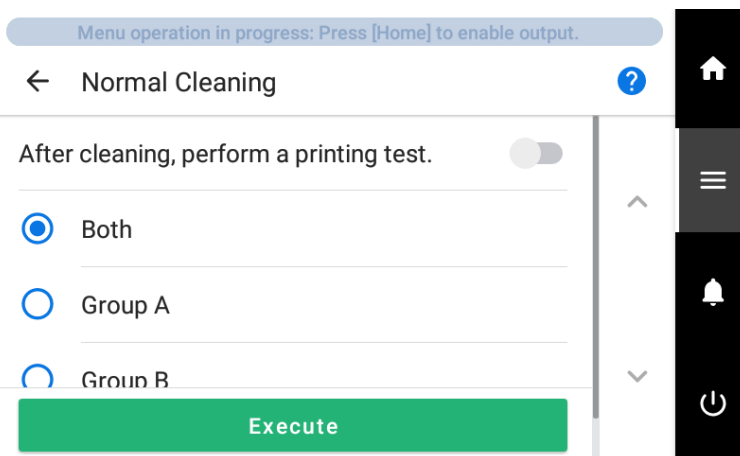

4. Select the group of print heads to clean.
5. Tap [Execute].
Cleaning will start. The status is displayed as [Normal cleaning in progress.] at the top of the operation panel.
On completion, you will return to the original screen.

6. Tap  .

7. Perform a printing test again.

8. Check to make sure the dot drop-out or dot displacement has been corrected.

If the problem persists, try performing normal cleaning again. If the printer has been used for a long period, dot drop-outs may not be fixed even after performing normal cleaning two or three times. If this is the case, clean using a different method.

RELATED LINKS

- [P. 132 Performing a Nozzle Drop-out Test](#)
- [P. 267 When Normal Cleaning Is Not Effective](#)

Starting Output

⚠ WARNING

Never touch the print-head carriage while output is in progress.

The print-head carriage moves at high speed. Coming into contact with the moving carriage may cause injury.

⚠ CAUTION

Do not touch the dancer roller needlessly.

The media take-up unit and feeder may move suddenly, which may result in injury.

IMPORTANT

If you are using white ink

Before the start of daily operations, remove just the white ink cartridge, shake it 50 times (about 20 seconds), and then reinsert it.

The ingredients in white ink tend to settle. Each day, before starting the day's operations, be sure to shake this cartridge. Allowing the ink to stand can cause the settled material to harden, resulting in malfunctions or other problems.

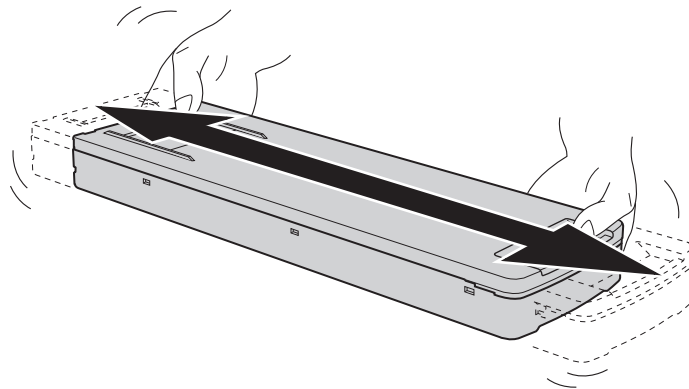

- Before shaking the ink cartridge, wipe off any ink from around its mouth. If you do not wipe off the ink, it may splatter when you shake the ink cartridge.
- When you shake the ink cartridge, firmly hold it with both hands to prevent the cover from coming loose. The cover or ink pouch coming loose and falling may cause damage or printer malfunctions.
- When you have finished mixing the ink, reattach the ink cartridge immediately. Taking time to reattach the ink cartridge will adversely affect the ink path.
- Even if you are not using the printer, shake the white ink cartridge 50 times (about 20 seconds) once a week.

Procedure

1. Close the front cover.
2. Make sure [Output possible.] is displayed at the top of the operation panel.
3. Send the output data from the computer.
For information on how to create the output data, refer to the documentation for the software RIP.

MEMO

- When you send the output data, [Ink circulation in progress.] or [Normal cleaning in progress.] may be displayed on the screen. These indicate the preparation operations performed before output. Output will begin after the time displayed on the screen elapses.
- If [Heater warm up in progress. Please wait.] is displayed, wait until the set temperature is reached.

- The data being output can be viewed as an image. Tap  shown in the following figure to switch to the remaining ink screen. Tap this icon again to return to the screen for checking the data being output. However, this functionality is limited to software RIPs that support the display of the output data image (thumbnail).

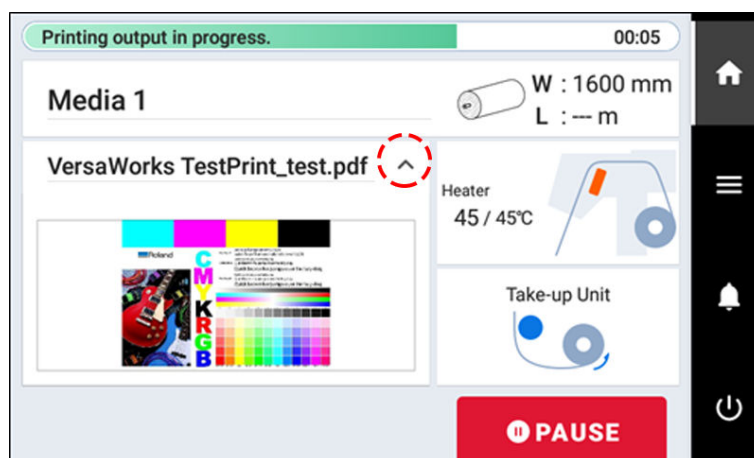

IMPORTANT

Output Is Not Possible in These Situations

- The machine does not run when a cover (front, left, right, or the rear UV shield) is open.
- Data from the computer is not accepted when [Load media.] is displayed.
- Output does not start while [Heater warm up in progress. Please wait.] is displayed.
- On menu screens where [Menu operation in progress: Press [Home] to enable output.] is displayed, output doesn't start even when data is sent from the computer. When you return to a menu item where output is possible or tap  to return to the home screen, output starts.

Points that must be observed

- Do not open a cover (front, left, right, or the rear UV shield) while output is in progress. Doing so interrupts printing.
- When you are performing printing, clamp the edges of the media with the media clamps. Otherwise, the edges of the media may warp and catch on the print heads.
- During output, do not touch the media. Doing so may obstruct the media feed or cause the media to rub against the print heads, which may result in a paper jam or damage to the heads.
- Keep the loading lever raised when the machine is not in use.

When not using the machine, remove any media and store it in a suitable environment.

- If the machine is left with the media loaded, the media may be damaged, which may adversely affect printing. When not using the machine, remove any media and store it in a suitable environment.

RELATED LINKS

- [P. 179 Setting the Standby Heater Temperature](#)

Cutting Method

Preparations for Cutting Output

Step 1: Switch off the heater.

MEMO

This work is not necessary if you have selected sheet media or created media with [Duplicating Media Settings for Cutting](#)(P. 217).

Procedure

1. Tap  to display the home screen.

2. Tap the following part.

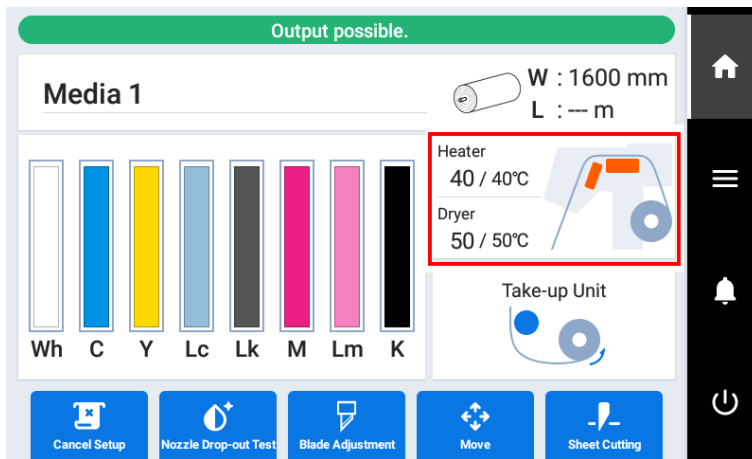

3. Check that Front Heater is off.

If Front Heater is on, tap  to turn it off .

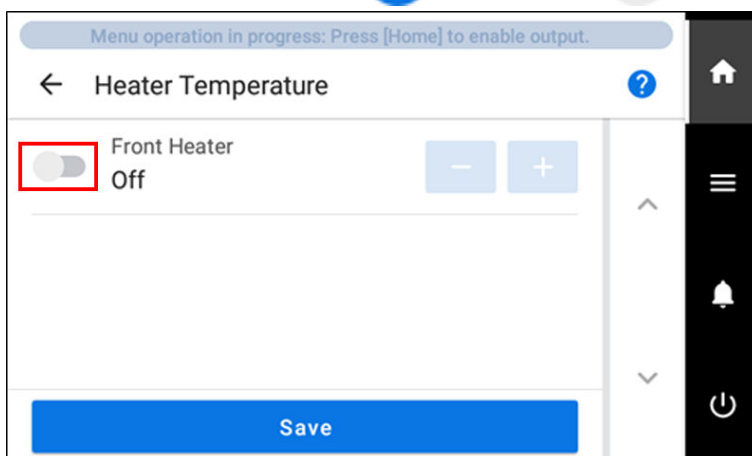



4. Tap [Save] to confirm your entry.

-
5. Tap  to go back to the original screen.

Step 2: Preventing Pulling of the Media with Undue Force

Procedure

1. Tap .
2. Tap [Preferences]>[Prefeeding at Output].
3. Select [Enable].
4. Tap [Save] to confirm your entry.
5. Tap  to go back to the original screen.

Step 3: Adjusting Cutting

For high-quality cutting, we recommend carrying out a cutting test to check the cutting quality for the media before you perform actual cutting. Adjust the blade force depending on the cutting quality.

Procedure

1. Close the front cover.
2. Tap  [Blade Adjustment] on the home screen.
3. Tap [Execute] next to [Cutting Test].
The test pattern is cut.
4. Peel off the cut shapes and change the [Blade Adjustment] settings according to the cutting quality.
Check that the two shapes are peeled off separately, a blade trace (red line) remains on the backing paper, and the backing paper is not cut.

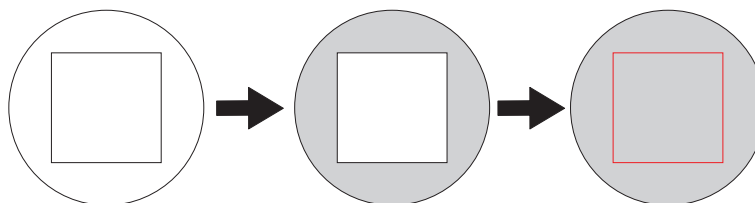

- **Two shapes are peeled off separately**
You do not need to perform the setting because the blade force is appropriate.
- **Two shapes are peeled off together**
Increase the blade force.
- **Backing paper is also cut**
Decrease the blade force.

5. Tap [Save].
The changed settings are saved.
6. Tap [Execute] next to [Cutting Test].
The test pattern is cut.
7. Check whether the correction was successful.

In the [Blade Adjustment] menu, you can also make settings for other cutting conditions in addition to the blade force.

RELATED LINKS

- [P. 183 Fine-tuning the Cutting Conditions](#)

Starting Output

⚠ WARNING

Never touch the cutting carriage while output is in progress.

The cutting carriage moves at high speed. Coming into contact with the moving carriage may cause injury.

⚠ CAUTION

Do not touch the dancer roller needlessly.

The media take-up unit and feeder may move suddenly, which may result in injury.

Procedure

1. Close the front cover.

2. Tap  to display the home screen.

3. Make sure [Output possible.] is displayed at the top of the operation panel.

4. Send the output data from the computer.

For information on how to create the output data, refer to the documentation for the software RIP.

IMPORTANT

Output Is Not Possible in These Situations

- The machine does not run when a cover (front, left, right, or the rear UV shield) is open.
- Data from the computer is not accepted when [Load media.] is displayed.
- On menu screens where [Menu operation in progress: Press [Home] to enable output.] is displayed, output doesn't start even when data is sent from the computer. When you return to a menu item where output is possible or tap  to return to the home screen, output starts.

Points that must be observed

- Do not open a cover (front, left, right, or the rear UV shield) while output is in progress. Doing so interrupts printing.
- When you are performing printing, clamp the edges of the media with the media clamps. Otherwise, the edges of the media may warp and catch on the print heads.
- During output, do not touch the media. Doing so may obstruct the media feed or cause the media to rub against the print heads, which may result in a paper jam or damage to the heads.
- Keep the loading lever raised when the machine is not in use.

When not using the machine, remove any media and store it in a suitable environment.

- If the machine is left with the media loaded, the media may be damaged, which may adversely affect printing. When not using the machine, remove any media and store it in a suitable environment.

Printing and Cutting Method

Preparations for Printing and Cutting Output

Step 1: Performing a Nozzle Drop-out Test

Before you carry out actual printing, perform a printing test to ensure no dot drop-out or dot displacement occurs. If dot drop-out or dot displacement occurs, perform cleaning of the print heads (normal cleaning).

MEMO

When performing printing tests successively, you can select **[Feed]** (vertical printing) or **[Scan]** (horizontal printing) as the printing position for the second and later tests in comparison to the first test.

[P. 222 Performing Printing Tests Arranged Horizontally](#)

Procedure

1. Set up the media.
2. Tap  **[Nozzle Drop-out Test]** on the home screen.
3. Tap **[Execute]** next to **[Printing Test]**.
Printing of the test pattern starts.

MEMO

Depending on the color of the media used, it may be difficult to check the white ink test pattern.

Tap  **[Nozzle Drop-out Test]** on the home screen, and then select **[Cleaning]>[Printing Test]>[Nozzle Drop-out Test (Base: Black)]** to make the base of the white ink black, making it easier to check the white ink. **[Nozzle Drop-out Test (Base: Black)]** is not displayed if the machine is not equipped with white ink.

4. Check whether there is dot drop-out or dot displacement in the test pattern.
Missing blocks indicate dot drop-out. Collapsed or inclined blocks indicate dot displacement.

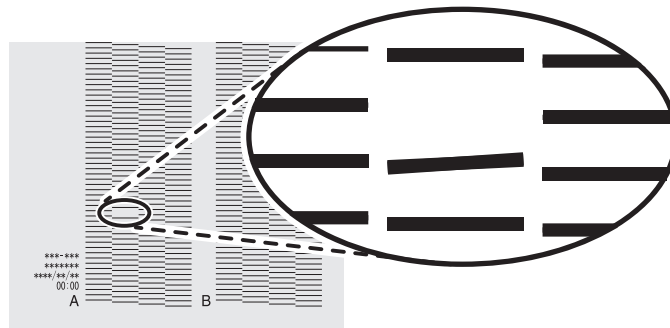

5. If you have opened the front cover, close it.
If no dot drop-out or dot displacement occurs, preparations for output are finished.

RELATED LINKS

- [P. 265 When Dot Drop-out or Dot Displacement Occurs](#)

Step 2: Normal Cleaning Method

MEMO

If the media has already been set up, the [After cleaning, perform a printing test.] menu appears on the [Normal Cleaning] screen. When this setting is turned on, a printing test is performed after cleaning.

Procedure

1. Check for the group with dot drop-out or dot displacement by viewing the results of the printing test. The space from "A" to "B" is group A. The space from "B" to the right side is group B.

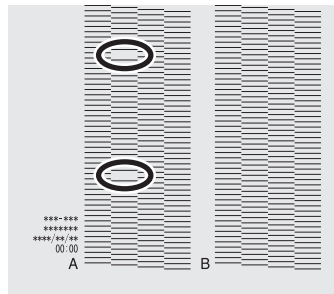

MEMO

If the printing-test results are difficult to interpret

Check the results in a bright location, changing your line of vision. They are visible using the reflection of the light.

2. Tap [Cleaning].
3. Tap [Normal Cleaning].
The screen shown below appears.

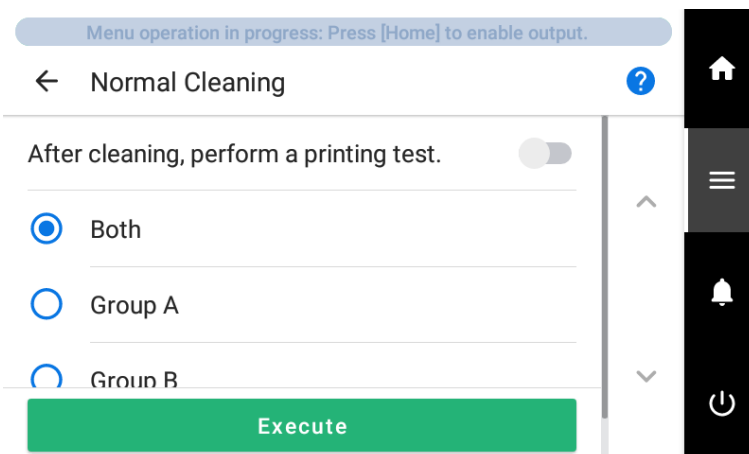

4. Select the group of print heads to clean.
5. Tap [Execute].
Cleaning will start. The status is displayed as [Normal cleaning in progress.] at the top of the operation panel.
On completion, you will return to the original screen.

6. Tap ← .

7. Perform a printing test again.

8. Check to make sure the dot drop-out or dot displacement has been corrected.

If the problem persists, try performing normal cleaning again. If the printer has been used for a long period, dot drop-outs may not be fixed even after performing normal cleaning two or three times. If this is the case, clean using a different method.

RELATED LINKS

- [P. 132 Performing a Nozzle Drop-out Test](#)
- [P. 267 When Normal Cleaning Is Not Effective](#)

Step 3: Adjusting Cutting

For high-quality cutting, we recommend carrying out a cutting test to check the cutting quality for the media before you perform actual cutting. Adjust the blade force depending on the cutting quality.

Procedure

1. Close the front cover.
2. Tap  [Blade Adjustment] on the home screen.
3. Tap [Execute] next to [Cutting Test].
The test pattern is cut.
4. Peel off the cut shapes and change the [Blade Adjustment] settings according to the cutting quality.
Check that the two shapes are peeled off separately, a blade trace (red line) remains on the backing paper, and the backing paper is not cut.

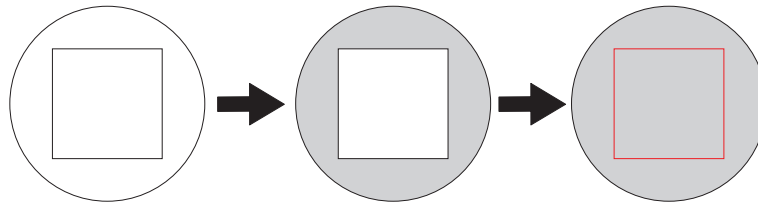

- **Two shapes are peeled off separately**
You do not need to perform the setting because the blade force is appropriate.
 - **Two shapes are peeled off together**
Increase the blade force.
 - **Backing paper is also cut**
Decrease the blade force.
5. Tap [Save].
The changed settings are saved.
 6. Tap [Execute] next to [Cutting Test].
The test pattern is cut.
 7. Check whether the correction was successful.

In the [Blade Adjustment] menu, you can also make settings for other cutting conditions in addition to the blade force.

RELATED LINKS

- [P. 183 Fine-tuning the Cutting Conditions](#)

Step 4: Correcting the Misalignment of Printing and Cutting

Procedure

1. Tap .
2. Tap [Media Settings]>[Cutting Settings]>[Print & Cut Position Adjustment].
3. Tap [Execute] next to [Printing Test 1 (Misalignment Check)].
Printing Test 1 is printed and cut. The test pattern is printed at each edge of the media.

MEMO

If the media is tilted, the positions at the edges will be misaligned. You can also adjust for misalignments due to the media being tilted by printing the test pattern at each edge.

4. Check the result of Printing Test 1.

Check whether the printing position (shaded part) and the cutting position (red line) are aligned. An example of the printing position and the cutting position being misaligned is shown in the following figure.

[F] indicates the feed direction of the media (the feed direction) and [S] indicates the direction of print head movement (the scan direction).

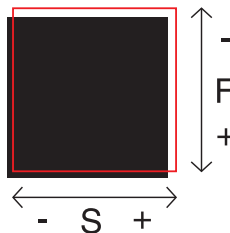

If the printing position and the cutting position are aligned, no corrections are necessary.

If the printing position and the cutting position are not aligned, proceed to the next procedure.

5. Tap [Execute] next to [Printing Test 2 (Correction Values)].
Printing Test 2 is printed and cut.



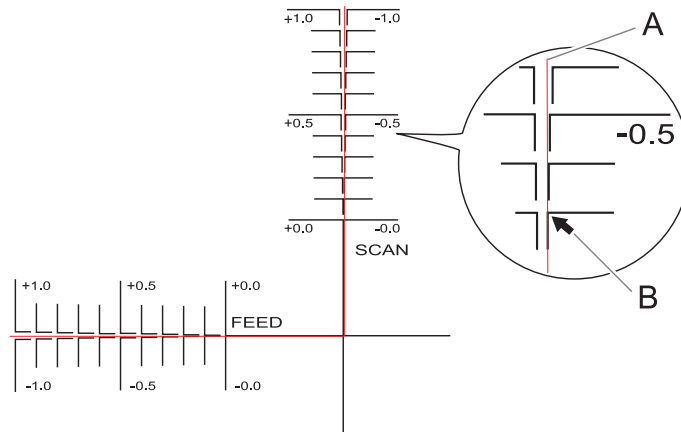

6. Check the correction values from the Printing Test 2 condition.

The point where the cutting line (A) intersects the correction-value scale (B) is the correction value. In the following figure, the correction value is "-0.3."

Check the media feed direction (the feed direction) and the direction of print head movement (the scan direction).





7. Set the correction values in the feed direction of the media (the feed direction) and the direction of print head movement (the scan direction).

- (1) Tap  or  next to [Correction Value (Feed)] to set the correction value in the feed direction of the media (the feed direction).
- (2) Tap  or  next to [Correction Value (Scan)] to set the correction value in the direction of print head movement (the scan direction).

8. Tap [Save].

The correction values are saved.

9. Tap [Execute] next to [Printing Test 1 (Misalignment Check)].

Printing Test 1 is printed and cut. If the printing and cutting lines are aligned, adjustment is complete. If further adjustment is needed, tap  or  next to [Correction Value (Feed)] and [Correction Value (Scan)] to fine-tune the printing and cutting position, and then [Save] the values.

MEMO

Default settings

- [Correction Value (Feed)] (correction value of the media feed direction): 0.00 mm
- [Correction Value (Scan)] (correction value of the print head movement direction): 0.00 mm

10. Tap  to go back to the original screen.

Starting Output

⚠ WARNING

Never touch the print-head carriage while output is in progress.

The print-head carriage moves at high speed. Coming into contact with the moving carriage may cause injury.

⚠ CAUTION

Do not touch the dancer roller needlessly.

The media take-up unit and feeder may move suddenly, which may result in injury.

IMPORTANT

If you are using white ink

Before the start of daily operations, remove just the white ink cartridge, shake it 50 times (about 20 seconds), and then reinsert it.

The ingredients in white ink tend to settle. Each day, before starting the day's operations, be sure to shake this cartridge. Allowing the ink to stand can cause the settled material to harden, resulting in malfunctions or other problems.

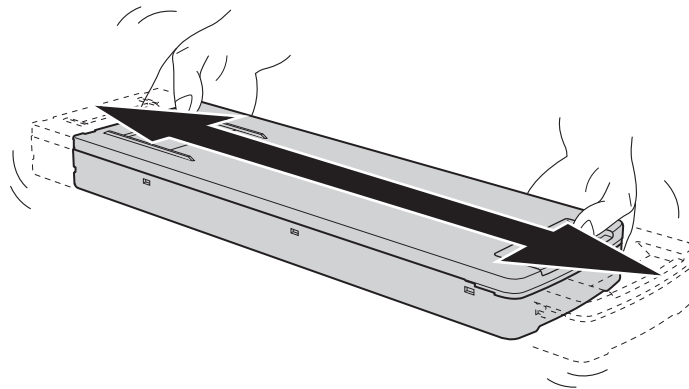

- Before shaking the ink cartridge, wipe off any ink from around its mouth. If you do not wipe off the ink, it may splatter when you shake the ink cartridge.
- When you shake the ink cartridge, firmly hold it with both hands to prevent the cover from coming loose. The cover or ink pouch coming loose and falling may cause damage or printer malfunctions.
- When you have finished mixing the ink, reattach the ink cartridge immediately. Taking time to reattach the ink cartridge will adversely affect the ink path.
- Even if you are not using the printer, shake the white ink cartridge 50 times (about 20 seconds) once a week.

Procedure

1. Close the front cover.
2. Make sure [Output possible.] is displayed at the top of the operation panel.
3. Send the output data from the computer.
For information on how to create the output data, refer to the documentation for the software RIP.

MEMO

- When you send the output data, [Ink circulation in progress.] or [Normal cleaning in progress.] may be displayed on the screen. These indicate the preparation operations performed before output. Output will begin after the time displayed on the screen elapses.
- If [Heater warm up in progress. Please wait.] is displayed, wait until the set temperature is reached.

- The data being output can be viewed as an image. Tap  shown in the following figure to switch to the remaining ink screen. Tap this icon again to return to the screen for checking the data being output. However, this functionality is limited to software RIPs that support the display of the output data image (thumbnail).

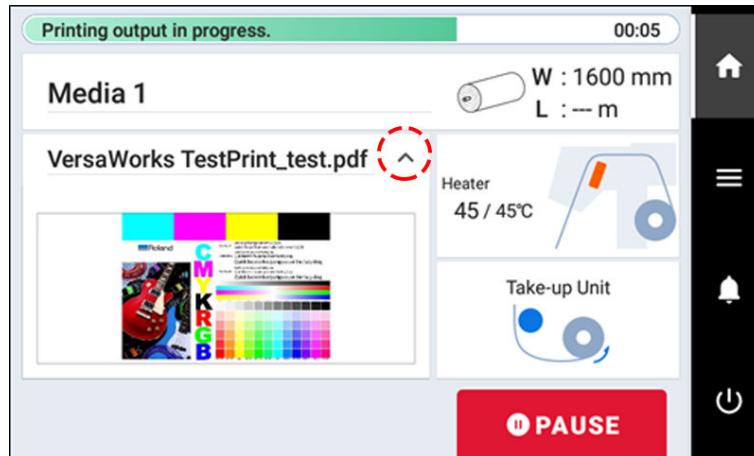

IMPORTANT

Output Is Not Possible in These Situations

- The machine does not run when a cover (front, left, right, or the rear UV shield) is open.
- Data from the computer is not accepted when [Load media.] is displayed.
- Output does not start while [Heater warm up in progress. Please wait.] is displayed.
- On menu screens where [Menu operation in progress: Press [Home] to enable output.] is displayed, output doesn't start even when data is sent from the computer. When you return to a menu item where output is possible or tap  to return to the home screen, output starts.

Points that must be observed

- Do not open a cover (front, left, right, or the rear UV shield) while output is in progress. Doing so interrupts printing.
- When you are performing printing, clamp the edges of the media with the media clamps. Otherwise, the edges of the media may warp and catch on the print heads.
- During output, do not touch the media. Doing so may obstruct the media feed or cause the media to rub against the print heads, which may result in a paper jam or damage to the heads.
- Keep the loading lever raised when the machine is not in use.

When not using the machine, remove any media and store it in a suitable environment.

- If the machine is left with the media loaded, the media may be damaged, which may adversely affect printing. When not using the machine, remove any media and store it in a suitable environment.

RELATED LINKS

- [P. 179 Setting the Standby Heater Temperature](#)

How to Cut with Crop Marks

Preparations for Output with Crop Marks

What Is Cutting with Crop Marks?

If you are removing the printed media and loading it again in order to cut it (for example, if you are processing the media such as laminating after printing, and then loading this media again for cutting), you have to align the printing and cutting positions. By printing the data together with crop marks, you can make it possible to align the positions using the crop marks when you load the media again to cut it. In this manual, this printing method is referred to as "cutting with crop marks."

"Crop marks" are marks used to align positions. They are also called "alignment marks."

Step 1: Performing a Nozzle Drop-out Test

Before you carry out actual printing, perform a printing test to ensure no dot drop-out or dot displacement occurs. If dot drop-out or dot displacement occurs, perform cleaning of the print heads (normal cleaning).

MEMO

When performing printing tests successively, you can select [Feed] (vertical printing) or [Scan] (horizontal printing) as the printing position for the second and later tests in comparison to the first test.

[P. 222 Performing Printing Tests Arranged Horizontally](#)

Procedure

1. Set up the media.
2. Tap  [Nozzle Drop-out Test] on the home screen.
3. Tap [Execute] next to [Printing Test].
Printing of the test pattern starts.

MEMO

Depending on the color of the media used, it may be difficult to check the white ink test pattern.

Tap  [Nozzle Drop-out Test] on the home screen, and then select [Cleaning]>[Printing Test]>[Nozzle Drop-out Test (Base: Black)] to make the base of the white ink black, making it easier to check the white ink. [Nozzle Drop-out Test (Base: Black)] is not displayed if the machine is not equipped with white ink.

4. Check whether there is dot drop-out or dot displacement in the test pattern.
Missing blocks indicate dot drop-out. Collapsed or inclined blocks indicate dot displacement.

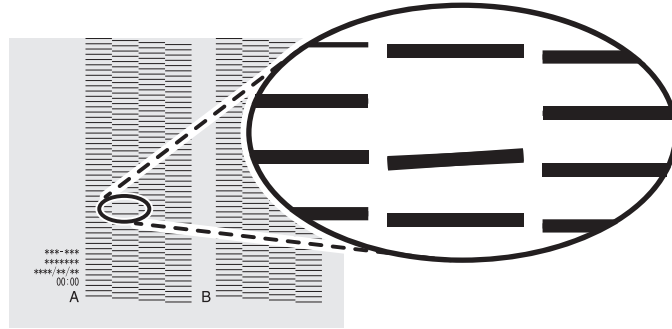

5. If you have opened the front cover, close it.
If no dot drop-out or dot displacement occurs, preparations for output are finished.

RELATED LINKS

- [P. 265 When Dot Drop-out or Dot Displacement Occurs](#)

Step 2: Normal Cleaning Method

MEMO

If the media has already been set up, the [After cleaning, perform a printing test.] menu appears on the [Normal Cleaning] screen. When this setting is turned on, a printing test is performed after cleaning.

Procedure

1. Check for the group with dot drop-out or dot displacement by viewing the results of the printing test. The space from "A" to "B" is group A. The space from "B" to the right side is group B.

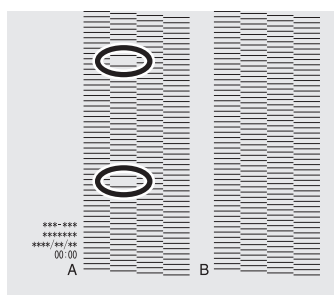

MEMO

If the printing-test results are difficult to interpret, check the results in a bright location, changing your line of vision. They are visible using the reflection of the light.

2. Tap [Cleaning].
3. Tap [Normal Cleaning].
The screen shown below appears.

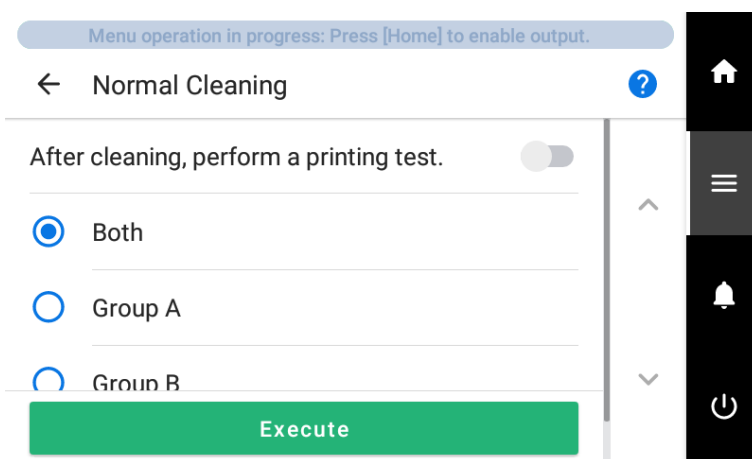

4. Select the group of print heads to clean.
5. Tap [Execute].
Cleaning will start. The status is displayed as [Normal cleaning in progress.] at the top of the operation panel.
On completion, you will return to the original screen.

6. Tap  .

7. Perform a printing test again.

8. Check to make sure the dot drop-out or dot displacement has been corrected.

If the problem persists, try performing normal cleaning again. If the printer has been used for a long period, dot drop-outs may not be fixed even after performing normal cleaning two or three times. If this is the case, clean using a different method.

RELATED LINKS

- [P. 132 Performing a Nozzle Drop-out Test](#)
- [P. 267 When Normal Cleaning Is Not Effective](#)

Step 3: Adjusting Cutting

For high-quality cutting, we recommend carrying out a cutting test to check the cutting quality for the media before you perform actual cutting. Adjust the blade force depending on the cutting quality.

Procedure

1. Close the front cover.
2. Tap  [Blade Adjustment] on the home screen.
3. Tap [Execute] next to [Cutting Test].
The test pattern is cut.
4. Peel off the cut shapes and change the [Blade Adjustment] settings according to the cutting quality.
Check that the two shapes are peeled off separately, a blade trace (red line) remains on the backing paper, and the backing paper is not cut.

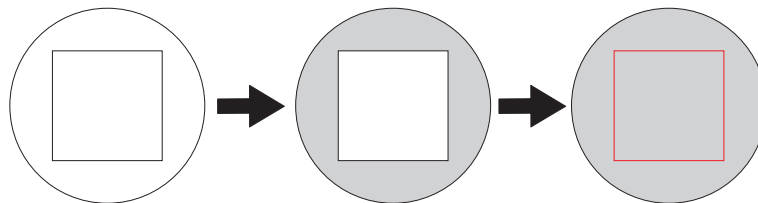

- **Two shapes are peeled off separately**
You do not need to perform the setting because the blade force is appropriate.
 - **Two shapes are peeled off together**
Increase the blade force.
 - **Backing paper is also cut**
Decrease the blade force.
5. Tap [Save].
The changed settings are saved.
 6. Tap [Execute] next to [Cutting Test].
The test pattern is cut.
 7. Check whether the correction was successful.

In the [Blade Adjustment] menu, you can also make settings for other cutting conditions in addition to the blade force.

RELATED LINKS

- [P. 183 Fine-tuning the Cutting Conditions](#)

Step 4: Correcting the Misalignment of Printing and Cutting with Crop Marks at the Same Time

Use the following procedure to print the crop marks and cut the media, checking for misalignment in the positions. In this section, the crop marks are printed simply, and then the crop marks are read and a cutting test is performed without removing the media. To simulate the actual process—printing crop marks, removing the media, and then performing post-processing such as laminating—before loading the media and checking for cutting position misalignment, turn on **[Separate Test for Printing/Cutting with Crop Marks]**. For more information, refer to [Correcting the Misalignment of Printing and Cutting with Crop Marks \(Separate Test for Printing/Cutting with Crop Marks\)](#)(P. 201).

Procedure

1. Tap .
2. Tap **[Media Settings]>[Cutting Settings]>[Crop Cut Position Adjustment]**.
3. Tap **[Execute]** next to **[Printing Test 1 (Misalignment Check)]**.
Printing Test 1 is printed and cut. One test pattern is printed on the media.

4. Check Printing Test 1.

Check whether the printing position (shaded part) and the cutting position (red line) are aligned. An example of the printing position and the cutting position being misaligned is shown in the following figure.

[F] indicates the feed direction of the media (the feed direction) and [S] indicates the direction of print head movement (the scan direction).

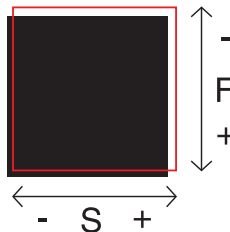



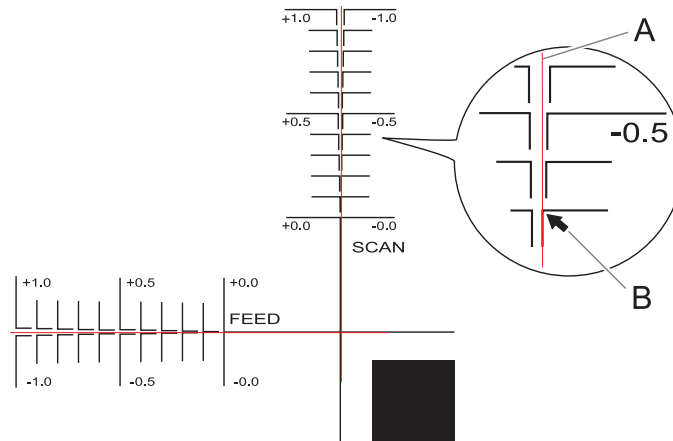

If the printing position and the cutting position are aligned, no corrections are necessary.

If the printing position and the cutting position are not aligned, proceed to the next procedure.



5. Tap **[Execute]** next to **[Printing Test 2 (Correction Values)]**.
Printing Test 2 is printed and cut.
6. Check the correction values from the Printing Test 2 condition.
The point where the cutting line (A) intersects the correction-value scale (B) is the correction value. In the following figure, the correction value is "-0.3."
Check the media feed direction (the feed direction) and the direction of print head movement (the scan direction).



7. Set the correction values in the feed direction of the media (the feed direction) and the direction of print head movement (the scan direction).

- (1) Tap  or  next to [Correction Value (Feed)] to set the correction value in the feed direction of the media (the feed direction).
- (2) Tap  or  next to [Correction Value (Scan)] to set the correction value in the direction of print head movement (the scan direction).

8. Tap [Save].
The correction values are saved.

9. Tap [Execute] next to [Printing Test 1 (Misalignment Check)].
Printing Test 1 is printed and cut. If the printing and cutting lines are aligned, adjustment is complete. If further adjustment is needed, tap  or  next to [Correction Value (Feed)] and [Correction Value (Scan)] to fine-tune the printing and cutting position, and then [Save] the values.

MEMO

- Default settings
 [Correction Value (Feed)] (correction value of the media feed direction): 0.00 mm
 [Correction Value (Scan)] (correction value of the print head movement direction): 0.00 mm
- Depending on the changes in the condition of media caused by laminating and the loading position of the media before cutting, the positioning of cutting may be misaligned. In such cases, correct the misalignment of printing and cutting with crop marks.

10. Tap  to go back to the original screen.

RELATED LINKS

- [P. 201 Correcting the Misalignment of Printing and Cutting with Crop Marks \(Separate Test for Printing/Cutting with Crop Marks\)](#)

Starting Output with Crop Marks

⚠ WARNING

Never touch the print-head carriage while output is in progress.

The print-head carriage moves at high speed. Coming into contact with the moving carriage may cause injury.

⚠ CAUTION

Do not touch the dancer roller needlessly.

The media take-up unit and feeder may move suddenly, which may result in injury.

MEMO

Prepare just the printing data, do not include the cutting data. Use your software RIP to configure the settings to print with crop marks. For information on how to make the settings, refer to the documentation for the software RIP you are using.

Procedure

1. Close the front cover.
2. Make sure [Output possible.] is displayed at the top of the operation panel.
3. Send the output data from the computer.

For information on how to create the output data, refer to the documentation for the software RIP.

MEMO

- When you send the output data, [Ink circulation in progress.] or [Normal cleaning in progress.] may be displayed on the screen. These indicate the preparation operations performed before output. Output will begin after the time displayed on the screen elapses.
- If [Heater warm up in progress. Please wait.] is displayed, wait until the set temperature is reached.
- The data being output can be viewed as an image. Tap  shown in the following figure to switch to the remaining ink screen. Tap this icon again to return to the screen for checking the data being output. However, this functionality is limited to software RIPs that support the display of the output data image (thumbnail).

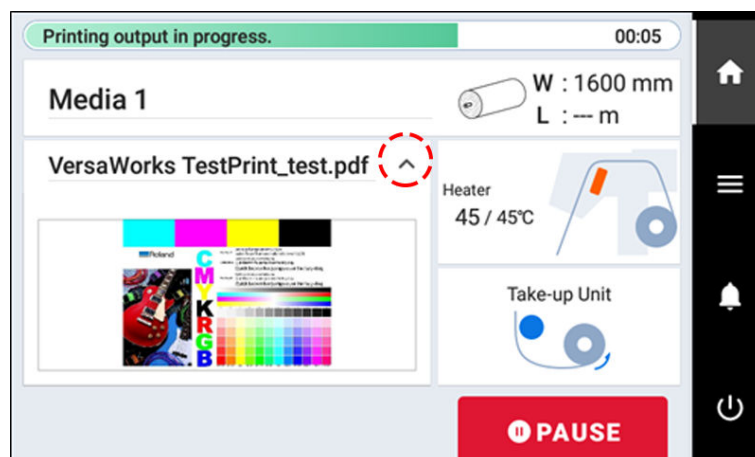

IMPORTANT

Output Is Not Possible in These Situations

- The machine does not run when a cover (front, left, right, or the rear UV shield) is open.
- Data from the computer is not accepted when [Load media.] is displayed.
- Output does not start while [Heater warm up in progress. Please wait.] is displayed.
- On menu screens where [Menu operation in progress: Press [Home] to enable output.] is displayed, output doesn't start even when data is sent from the computer. When you return to a menu item where output is possible or tap  to return to the home screen, output starts.

Points that must be observed

- Do not open a cover (front, left, right, or the rear UV shield) while output is in progress. Doing so interrupts printing.
- When you are performing printing, clamp the edges of the media with the media clamps. Otherwise, the edges of the media may warp and catch on the print heads.
- During output, do not touch the media. Doing so may obstruct the media feed or cause the media to rub against the print heads, which may result in a paper jam or damage to the heads.
- Keep the loading lever raised when the machine is not in use.

When not using the machine, remove any media and store it in a suitable environment.

- If the machine is left with the media loaded, the media may be damaged, which may adversely affect printing. When not using the machine, remove any media and store it in a suitable environment.

RELATED LINKS

- [P. 179 Setting the Standby Heater Temperature](#)

Preparations for Cutting Output

Step 1: Loading Media with Crop Marks

Procedure

1. Load the media on which crop marks have been printed.

Place the front left and right crop marks so they are straight and aligned with the blade protector (A).

IMPORTANT

Ensure that the crop marks are not angled by more than 5 degrees. Crop marks cannot be read at higher angles.

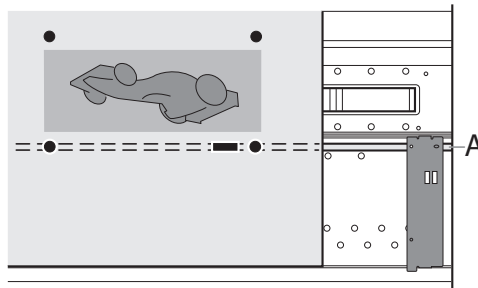

2. Finish the media setup and check that the home screen is displayed.

This completes the setup of the media with crop marks. Proceed to [Step 1: Switch off the heater](#) (P. 138).

RELATED LINKS

- [P. 31 Setup of New Media](#)
- [P. 70 Setup of Registered Media](#)
- [P. 359 Printing/Cutting Area](#)

Step 2: Switch off the heater.

MEMO

This work is not necessary if you have selected sheet media or created media with [Duplicating Media Settings for Cutting](#)(P. 217).

Procedure

1. Tap  to display the home screen.

2. Tap the following part.

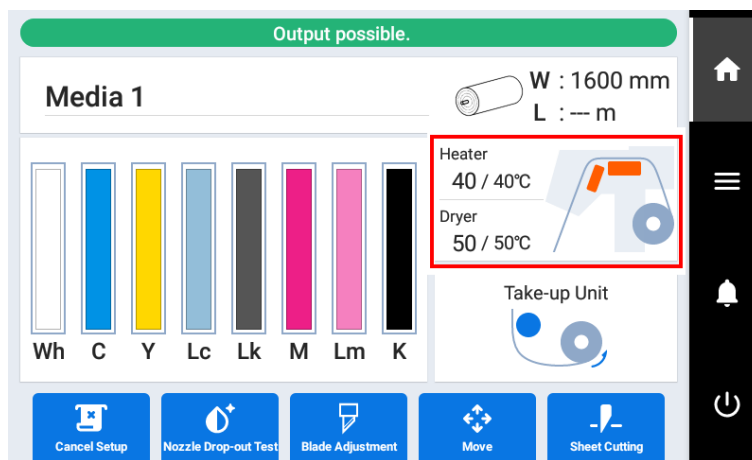

3. Check that Front Heater is off.

If Front Heater is on, tap  to turn it off .

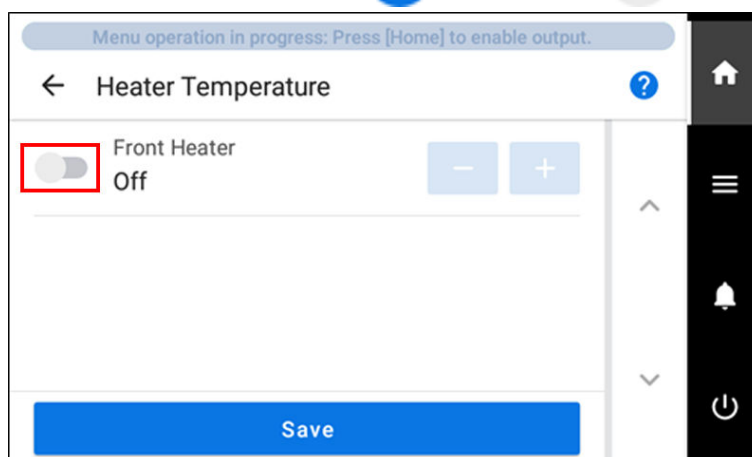



4. Tap [Save] to confirm your entry.

5. Tap  to go back to the original screen.

Step 3: Preventing Pulling of the Media with Undue Force

Procedure

1. Tap .
2. Tap [Preferences]>[Prefeeding at Output].
3. Select [Enable].
4. Tap [Save] to confirm your entry.
5. Tap  to go back to the original screen.

Starting Cutting Output

⚠ WARNING

Never touch the cutting carriage while output is in progress.

The cutting carriage moves at high speed. Coming into contact with the moving carriage may cause injury.

⚠ CAUTION

Do not touch the dancer roller needlessly.

The media take-up unit and feeder may move suddenly, which may result in injury.

MEMO

Prepare just the cutting data, do not include the printing data.

Procedure

1. Close the front cover.
2. Tap  to display the home screen.
3. Make sure [Output possible.] is displayed at the top of the operation panel.
4. Send the output data from the computer.
For information on how to create the output data, refer to the documentation for the software RIP.

IMPORTANT

Output Is Not Possible in These Situations

- The machine does not run when a cover (front, left, right, or the rear UV shield) is open.
- Data from the computer is not accepted when [Load media.] is displayed.
- On menu screens where [Menu operation in progress: Press [Home] to enable output.] is displayed, output doesn't start even when data is sent from the computer. When you return to a menu item where output is possible or tap  to return to the home screen, output starts.

Points that must be observed

- Do not open a cover (front, left, right, or the rear UV shield) while output is in progress. Doing so interrupts printing.
- When you are performing printing, clamp the edges of the media with the media clamps. Otherwise, the edges of the media may warp and catch on the print heads.
- During output, do not touch the media. Doing so may obstruct the media feed or cause the media to rub against the print heads, which may result in a paper jam or damage to the heads.
- Keep the loading lever raised when the machine is not in use.

When not using the machine, remove any media and store it in a suitable environment.

- If the machine is left with the media loaded, the media may be damaged, which may adversely affect printing. When not using the machine, remove any media and store it in a suitable environment.

Optimizing Quality and Efficiency

Optimizing the Output Quality

Using the Correction Functions.....	167
Automatically Making Required Adjustments	167
Manual Adjustment: Reducing Horizontal Bands (Feed Correction)	168
Manual Adjustment: Adjusting the Misalignment of the Ink Landing Position (Media Gap Adjustment).....	170
Configuring Settings to Match the Properties of the Media	172
Changing the Print Head Height	172
Using Media That Wrinkles Easily/Does Not Move Smoothly	174
Setting the Take-up Unit	175
Preventing Misaligned Media.....	177
Use Middle Pinch Rollers When Pulling Back or Feeding Media	177
Heating the Media to Prevent It from Coming Loose.....	178
Setting the Standby Heater Temperature	179
Setting the Output Heater Temperature	181
Accurately Adjusting the Cutting Settings.....	183
Fine-tuning the Cutting Conditions.....	183
Accurately Adjusting the Cutting-in Amount.....	185
Making Adjustments When Cutting the Print Surface.....	186
Performing Distance Correction during Cutting	189
Cutting to Make It Possible to Cut Corners Attractively (Over Cut)	190
Prioritizing the Cutting Settings of This Machine over the Software RIP Settings....	192
Accurately Adjusting the Settings for Printing and Cutting	193
Correcting the Misalignment of Printing and Cutting.....	193
Correcting the Misalignment of the Printing and Cutting Positions during Cutting ..	196
Accurately Adjusting the Settings for Cutting with Crop Marks	198
Correcting the Misalignment of Printing and Cutting with Crop Marks (Concur- rent Test for Printing and Cutting with Crop Marks).....	198
Correcting the Misalignment of Printing and Cutting with Crop Marks (Sepa- rate Test for Printing/Cutting with Crop Marks)	201
Correcting the Reading Sensor	206
Avoiding Printing Cancellation Due to Cleaning.....	207
Cleaning during Printing.....	207

Using the Correction Functions

To optimize the output quality, it is effective to use some correction functions.

Automatically Making Required Adjustments

To optimize the output quality, corrections must match the media and printing conditions.

Depending on the printing conditions, the ink landing position may be misaligned and the movement distance may change subtly during media feeding. Automatically correct these issues to match the media.

First, print a test pattern. Then read this pattern with the multi sensor and automatically enter the correction values.

Executing automatic correction prints a test pattern, reads this pattern, and enters the correction values for the following operations.

- Multi sensor adjustment (adjusting to the optimal condition the sensor used in correction)
- Media gap adjustment (correcting the ink landing position)
- Feed correction (to reduce horizontal bands)

Procedure

1. Set up the media.

2. Close the front cover.

3. Tap .

4. Tap [Media Settings]>[Printing Settings]>[Batch Automatic Correction].

5. Tap [Execute].

Test patterns are printed and correction values are entered for the following operations.

- Multi Sensor Adjustment
- Feed Correction
- Media Gap Adjustment

6. Tap [OK] when the completion screen appears.

7. Perform the operations shown below according to the [Result].

- If [Successful] is displayed on the operation panel, tap  to go back to the original screen.
- If [Failed] is displayed on the operation panel, carry out manual adjustment.

RELATED LINKS

- [P. 168 Manual Adjustment: Reducing Horizontal Bands \(Feed Correction\)](#)
- [P. 170 Manual Adjustment: Adjusting the Misalignment of the Ink Landing Position \(Media Gap Adjustment\)](#)



Manual Adjustment: Reducing Horizontal Bands (Feed Correction)

Perform corrections to make the band-shaped "stripes" on the printed surface less noticeable.

The band-shaped "stripes" are called "horizontal bands" or "banding." Horizontal bands are caused by the subtle changes in the movement distance that occur when feeding the media depending on the media's thickness and the temperature of the front heater. We recommend that you make corrections to match the media you are using and the set temperature of the front heater.

First, print a test pattern, and then determine and enter the correction value. After entering the correction value, print a test pattern again and check the correction results. Repeat the process of printing a test pattern and entering a correction value several times to find the optimal correction value.



Procedure

1. Set up the media.
2. Close the front cover.
3. Tap .
4. Tap [Media Settings]>[Printing Settings]>[Feed Correction].
5. Select [Detailed Correction (Manual)] and tap [Next].
6. Tap [Execute] next to [Printing Test].
Printing of the test pattern starts.
7. Check the printed test pattern, and then tap  or  to enter the correction value.

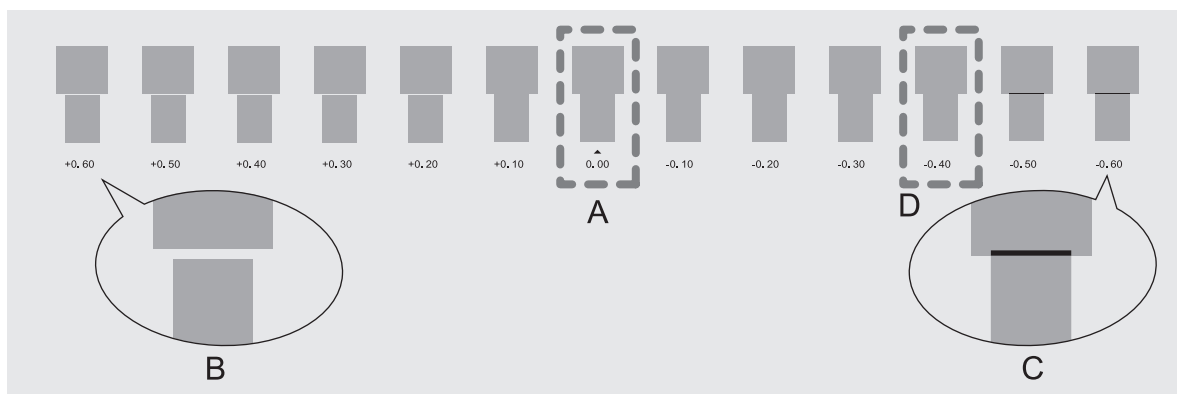
The current correction value (A) is that of the figure indicated by "▲." Select the value to make the gap (B) and overlap (C) between the upper/lower squares smallest. In the case of the following figure, select "-0.40" (D). When you cannot choose between two sequential numbers, specify a value that is between them.



MEMO

- If the test pattern is difficult to see, tap  or  next to [Media Feed] to move the media to a position where it is easier to see.

- If you want to hold the media to check the test pattern, tap [Execute] next to [Sheet Cutting] to separate the media.

8. Tap [Save].
The entered correction value is saved.
9. Tap [Execute] next to [Printing Test].
The test pattern is printed again.
10. Check the test pattern to see whether the correction was successful.
Check that the gap and overlap are the smallest for the figure indicated by "▲" (that is, the current correction value). If the gap and overlap are smaller for another figure, set the correction value again.
11. When you have successfully performed the correction, tap  to go back to the original screen.

Manual Adjustment: Adjusting the Misalignment of the Ink Landing Position (Media Gap Adjustment)



This adjusts the landing position of the ink discharged from the print heads. The landing position varies according to the print head height and the thickness of the media, so we recommend that you make corrections to match the media you are using.

First, print a test pattern, and then determine and enter the correction value. After entering the correction value, print a test pattern again and check the correction results.

This adjustment must be performed in the following cases.



- When using this machine for the first time
- When changing the media to use
- When you have changed the print-head height

Procedure

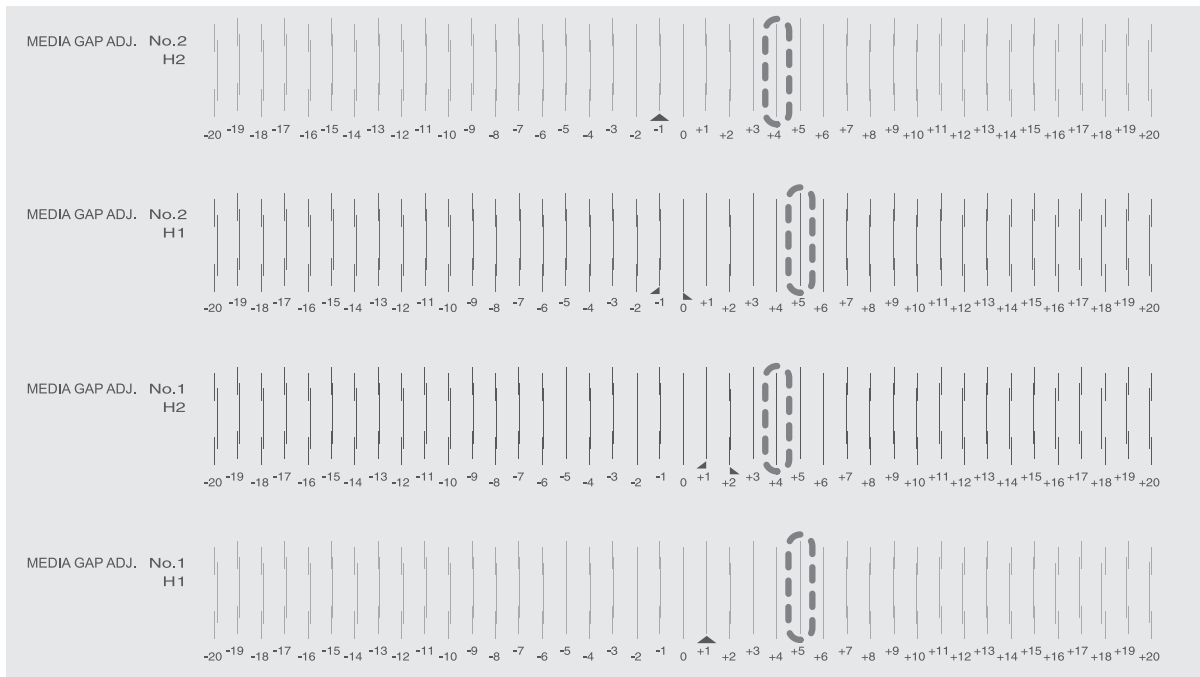
1. Set up the media.
2. Close the front cover.
3. Tap .
4. Tap [Media Settings]>[Printing Settings]>[Media Gap Adjustment].
5. Select [Detailed Correction (Manual)] and tap [Next].
6. Tap [Execute] next to [Printing Test].
Printing of the test pattern starts.
7. Check the printed test pattern, and then tap  or  to enter the H1 and H2 correction values for No. 1 and the H1 and H2 correction values for No. 2.
Select the value that gives the least misalignment between the two lines. In the case of the following figure, select "+5" for H1 for No. 1 and No. 2 and "+4" for H2 for No. 1 and No. 2. When you cannot choose between two sequential numbers, select a value that is between them (you can set correction values in units of "0.5").



MEMO

- If the test pattern is difficult to see, tap  or  next to [Media Feed] to move the media to a position where it is easier to see.
- If you want to hold the media to check the test pattern, tap [Execute] next to [Sheet Cutting] to separate the media.

[P. 109 Separating the Media](#)

8. Tap [Save].

The entered correction values are saved.

9. Tap [Execute] next to [Printing Test].

The test pattern is printed again.

10. Check the test pattern to see whether the correction was successful.

For all the correction values, check that the misalignment is minimized for the two vertical lines indicated by "▲" (that is, the current correction value). If the misalignment is smaller for another set of vertical lines, set the correction value again.

11. When you have successfully performed the correction, tap  to go back to the original screen.

Configuring Settings to Match the Properties of the Media

Changing the Print Head Height

This adjusts the print head height to prevent media that is wrinkled or comes loose from the platen from contacting the print heads.

You can select the print head height from [Low], [Medium], and [High]. Printing quality when the print head height is set to [Medium] or [High] may be coarser or otherwise lower than when set to [Low].

Procedure

1. Set up the media.

2. Tap .

3. Tap [Media Settings]>[Printing Settings]>[Print Head Height].

4. Tap [Change].

The print heads move to a position where they can be operated.

5. Open the front cover.

6. Move the height-adjustment lever to adjust the print head height.

When you change the position of the height-adjustment lever, the display screen will change.

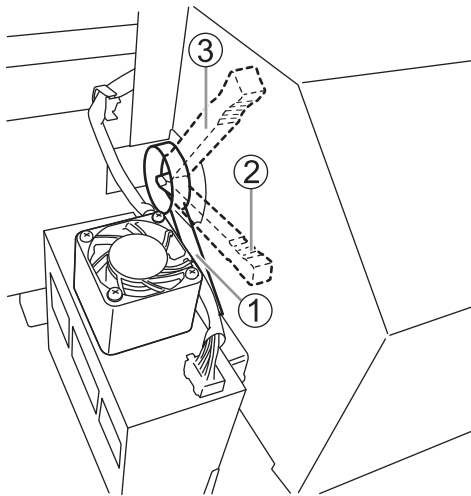

Position	Operation panel display	Description
①	[Low]	Normally set the height-adjustment lever to [Low].
②	[Medium]	For media that is wrinkled or comes loose from the platen during printing, set the height-adjustment lever to [Medium].
③	[High]	For media that is wrinkled or comes loose from the platen during printing even when the height-adjustment lever is set to [Medium], set the lever to [High].

IMPORTANT

The printing quality degrades as the distance between the media and the print heads increases. Do not move the height-adjustment lever to [Medium] or [High] needlessly.

7. Close the front cover.
8. Tap [OK].
The print heads move to their original position.
9. Tap  to go back to the original screen.

MEMO

- Default setting: [Low]
- If degradation of printing quality occurs after raising the print head height, refer to the following information and try optimizing the quality.

RELATED LINKS

- [P. 167 Automatically Making Required Adjustments](#)
- [P. 170 Manual Adjustment: Adjusting the Misalignment of the Ink Landing Position \(Media Gap Adjustment\)](#)

Using Media That Wrinkles Easily/Does Not Move Smoothly

The platen uses suction to grip the media and keep it stable. The suction force can be adjusted corresponding to the nature and condition of the media.

Procedure

1. Set up the media.

2. Tap .

3. Tap [Media Settings]>[Other Media Settings]>[Media Suction Force].

4. Tap  or  to enter the value.

0 to 100%	When the media is flimsy and cannot move smoothly, decreasing this value (reducing the suction force) may correct the problem.
Auto	The suction force is automatically adjusted to the optimal level for the media width

5. Tap [Save] to confirm your entry.

6. Tap  to go back to the original screen.

MEMO

- Default setting: [Auto]
- Depending on the software RIP you are using, you can also make this setting in the software RIP. When you have made the setting in the software RIP, the machine's setting is ignored.

Setting the Take-up Unit

When using a take-up unit, make sure the following settings match the take-up method and output method of the actual media.

The settings will have to be changed from the defaults when:

- Just printing on weak media and not cutting.
- Taking-up the media with inward curl.
- When printing multiple colors of ink in layers such as by printing CMYK ink on top of white ink.

Procedure

1. Tap .

2. Tap [Preferences]>[Take-up].

3. Tap [Take-up Method].

4. Select the setting from those shown below and tap [Save].

[Loose Winding]	The media is taken up with some slack. This is suited to PVC and other such stiff or slippery media.
[Tension Winding]	The media is stretched and taken up. This is suited to tarpaulin and other such weak media and media that does not slip easily.
[Batch Winding]	Media is taken up after the output of the piece of data is finished. This is suited to output data in which colors are printed in layers. ^{*1}

*1 No take-up is performed during output, so the media will touch the floor when data that is long in the feed direction is printed. Before printing, place clean cardboard or something similar on the floor to prevent the print surface from getting dirty.

IMPORTANT

When the output data includes the cutting operation, this setting is ignored, and no take-up is performed until the output of the piece of data is finished.

MEMO

- Default setting: [Loose Winding]

5. Tap [Take-up Direction].

6. Select the setting from those shown below and tap [Save].

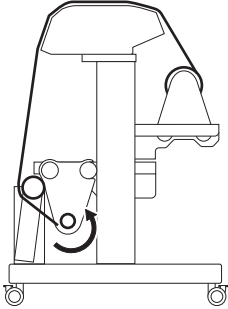
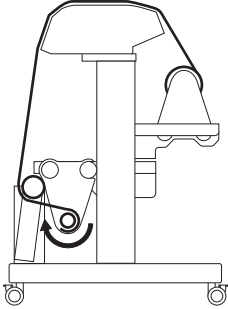
<p>[Forward]</p>	<p>The media is taken up onto the paper tube with the printed surface on the outside.</p> 
<p>[Backward]</p>	<p>The media is taken up onto the paper tube with the printed surface on the inside.</p> 

MEMO

- Default setting: [Forward]

7. Tap  to go back to the original screen.

Preventing Misaligned Media

Use Middle Pinch Rollers When Pulling Back or Feeding Media

Set the setting that causes the middle pinch rollers to go up automatically during pullback printing or printing and cutting to **[Disable]**. Holding down media that is not straight or comes loose is effective in preventing misalignment during printing and cutting.

[Middle Pinch Auto Raise/Lower] is a function that causes the middle pinch rollers to automatically rise when media is pulled back, performs overprinting and cutting while they are raised. However, if you are performing lengthy printing or using non-resilient media, the media will be skewed or will come loose, which may have an effect on the output quality.

If you set **[Middle Pinch Auto Raise/Lower]** to **[Disable]**, the middle pinch rollers will press down on the media while moving, thus preventing skewing or coming loose. However, because the middle pinch rollers are pressed against the printed surface, it is easier for the rollers to leave a trace on the printed surface. Before pulling back the media, make sure to dry it thoroughly.

Procedure

1. Set up the media.

2. Tap .

3. Tap **[Media Settings]>[Other Media Settings]>[Middle Pinch Auto Raise/Lower]**.

4. Select **[Disable]**.

The middle pinch rollers will lower during media feeding and pullback, pressing down on the media while moving.

5. Tap **[Save]** to confirm your entry.

6. Tap  to go back to the original screen.

MEMO

- Default setting: **[Enable]**

RELATED LINKS

- [P. 178 Heating the Media to Prevent It from Coming Loose](#)

Heating the Media to Prevent It from Coming Loose

This machine's apron is equipped with a front heater (①), which heats the media. Heating the media makes it flexible, preventing the media from coming loose from the platen. You can adjust the temperature settings to match the type of media and the printing speed.

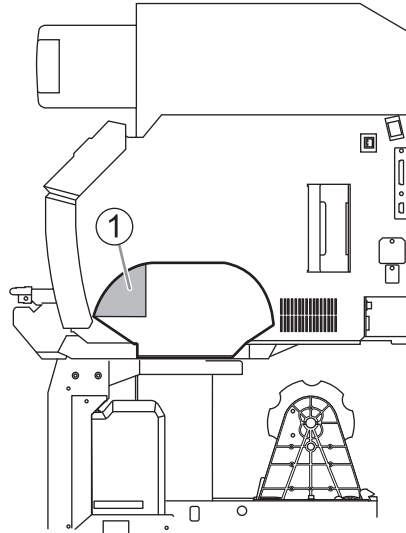

⚠ WARNING

High Temperature

Areas such as the heater become hot. Exercise caution to avoid burns.

⚠ WARNING

Remove any loaded media or switch off the sub power when printing is not being performed.

The continued application of heat at a single location may cause the release of toxic gases from the media or pose a fire hazard.

⚠ WARNING

Never use media that cannot withstand heat.

Doing so may degrade the media, or may result in fire or the release of toxic gases.

⚠ WARNING

Never use the heater for any purpose for which it is not intended, such as to dry clothing.

Doing so may cause overheating, resulting in fire or accident.

IMPORTANT

Use the machine in an environment with an ambient temperature of 20 to 32 °C (68 to 90 °F).

If the machine is used at an ambient temperature lower than 20 °C (68 °F), then depending on the type or width of the media, wrinkling or temperature-caused unevenness may occur. If this happens, try lowering the temperature of the media heating system by about 2 °C. To obtain stable printing results, however, use the machine in an environment with an ambient temperature of 20 °C to 32 °C (68 °F to 89.6 °F).

Setting the Standby Heater Temperature



Depending on the usage environment, the temperature of the dryer may become higher than the set temperature, but this does not represent a problem.

Procedure

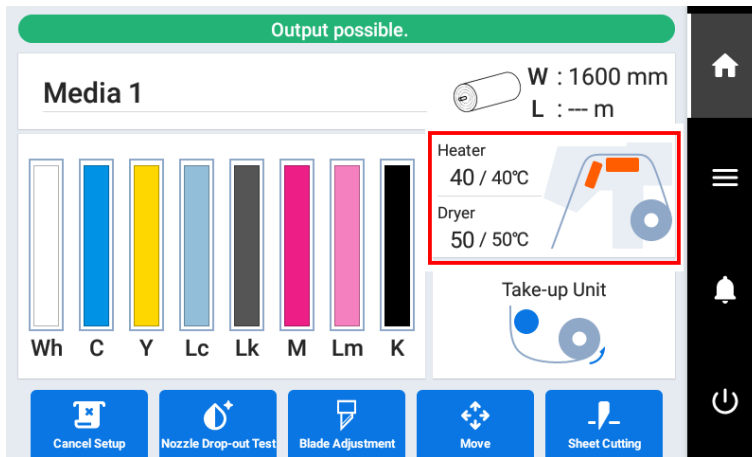
1. Check that the loading lever is raised.
2. Tap the following location on the home screen.



The [Standby Heater Temperature] screen appears.

3. Tap  to turn [Standby Heater Temperature] on .

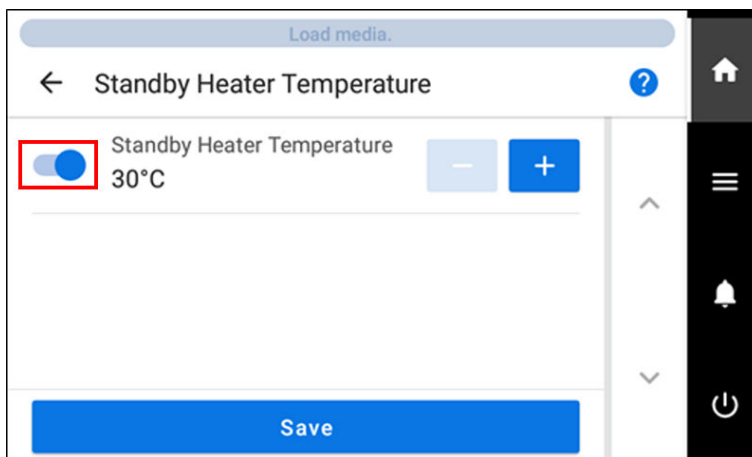

4. Tap  or  to set the [Standby Heater Temperature].

Temperature settings are not possible when [Standby Heater Temperature] is set to . A temperature that is too high may degrade the media or cause it to wrinkle.

5. Tap [Save] to confirm your entry.

6. Tap  to go back to the original screen.

MEMO

- Default setting: Off

Setting the Output Heater Temperature



Depending on the usage environment, the temperature of the dryer may become higher than the set temperature, but this does not represent a problem.

Procedure

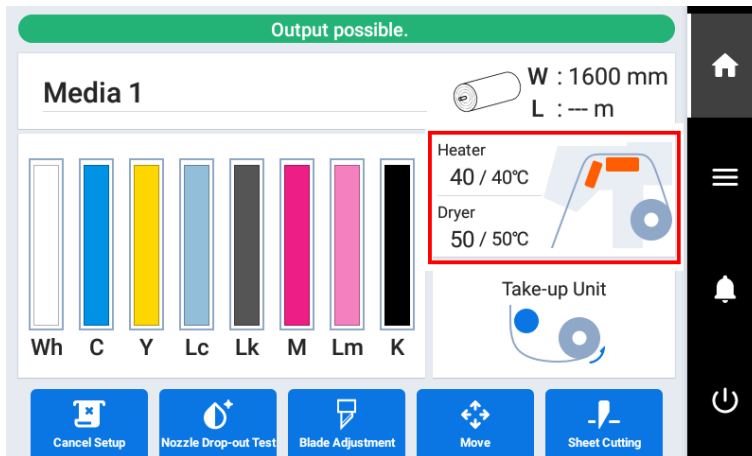

1. Set up the media.
2. Tap the following location on the home screen.

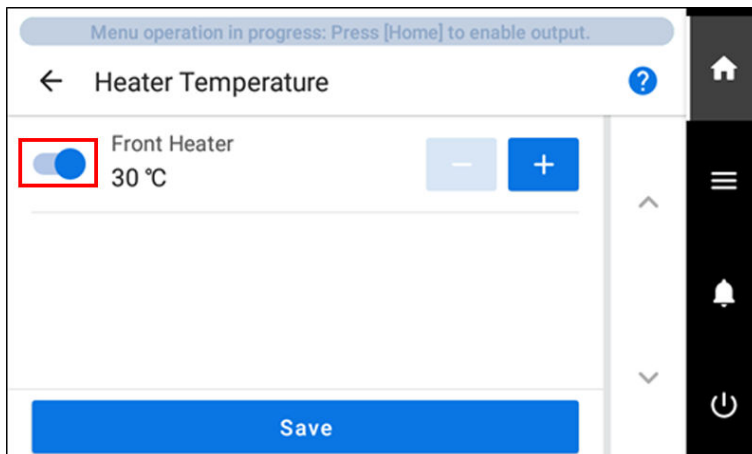

The [Heater Temperature] screen appears.

3. Tap  to turn [Front Heater] on .



4. Tap  or  to set the temperature of the [Front Heater].

Temperature settings are not possible when [Front Heater] is set to .
A temperature that is too high may degrade the media or cause it to wrinkle.

5. Tap [Save] to confirm your entry.

6. Tap  to go back to the original screen.

MEMO

- Default setting: Off

Accurately Adjusting the Cutting Settings



Fine-tuning the Cutting Conditions

You can accurately set items such as the blade force, movement speed, and blade offset to match the nature of the media and the shape to cut. First, perform a cutting test, and then determine and enter the setting values. After entering the setting values, perform a cutting test again and check the results. Repeat the process of performing a cutting test and making the settings several times to find the optimal setting values.

Procedure

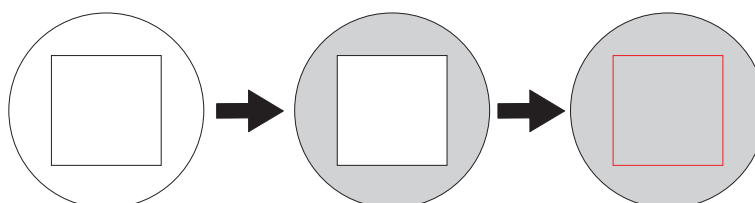
1. Set up the media.
2. Close the front cover.
3. Tap  [Blade Adjustment] on the home screen.
4. Tap [Execute] next to [Cutting Test].
The test pattern is cut.
5. Check the results of the cutting test.
If the results are difficult to see, [Execute] [Sheet Cutting], separate the media, and then hold it to check the results.



Check item	Result	Setting item	Adjustment
Check the shape.	The cut shape is distorted.	[Cutting Speed]	Reduce
Peel off the circle.	The square also peels off.	[Blade Force]	Increase
	Some uncut areas remain.	[Cutting Speed]	Reduce
Peel off the square.	The blade leaves faint traces on the backing paper.	[Blade Force]	No change
	The blade trace is indistinct.		Increase
	The blade trace is too deep and cuts into the backing paper.		Reduce
Check the shape of the square you have peeled off.	 The corners are not rounded and do not have "horns."	[Blade Offset]	No change
	 The corners are rounded.		Increase
	 The corners have "horns."		Reduce

6. Tap  or  to change the settings.

Display screen (cutting conditions)	Setting details	Default settings
[Blade Force]	Set the force (pressure) of the blade.	50 gf
[Cutting Speed]	Set the speed of cutting.	30 cm/s
[Blade Offset]	Set the blade offset. Enter the listed offset value for the blade. The offset value for the included blade is 0.250 mm (9.8 mil).	0.250 mm (0.010 in.)
[Rise Movement Speed]	Set the blade's up speed during cutting (the speed at which the blade travels when it moves to the next cutting line after cutting one cutting line). If the media comes loose during no-load feed and the blade damages the surface of the media, reduce the speed.	30 cm/s

7. Tap [Save] to confirm your entry.

8. Tap  to go back to the original screen.

Accurately Adjusting the Cutting-in Amount

When you want to perform accurate and fine adjustment of the cutting-in amount, such as when cutting media with thin backing paper, you can obtain good results by adjusting the amount of blade extension. Turn the cap portion of the blade holder to adjust the amount of blade extension. Each indicator tick corresponds to 0.1 mm (3.9 mil), and adjustment for 0.5 mm (19.7 mil) can be made by rotating the cap one full turn.

Note that making the amount of blade extension too small may cause the tip of the blade holder cap to touch the printed surface, soiling and damaging it. It is important to be especially careful about this when you are using media that has poor ink-adhesion properties.

The amount of blade extension (A) is 0 mm (0 in.) at minimum and 2.5 mm (98.42 mil) (C) at maximum.

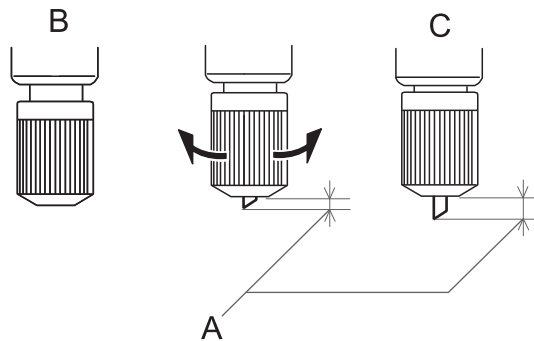

Rough Estimate for the Amount of Blade Extension (When Creating a Sticker)

Set the amount of blade extension (A) to an amount that is the sum of the thickness of the material portion (D) and half (F) the thickness of the backing paper (E).

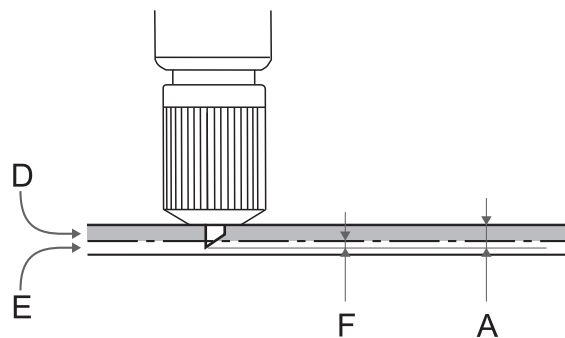

Rough Estimate for the Amount of Blade Extension (When Cutting Perforated Lines)

Set the amount of blade extension (A) so that when the blade pierces the media (G), the blade tip extends slightly.

For information about the output settings for cutting perforated lines, refer to the documentation for VersaWorks.

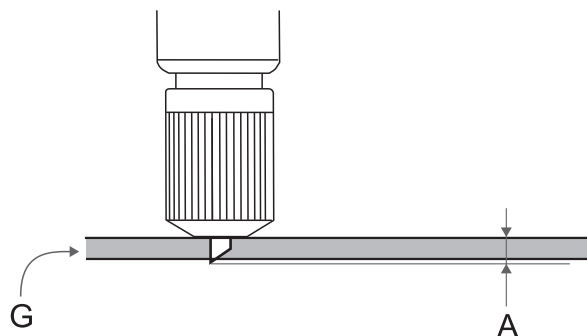

IMPORTANT

Pushing the blade out too far will damage the blade and blade protector and hasten their deterioration, so exercise caution.

Making Adjustments When Cutting the Print Surface

Hardened ink is thick. Therefore, the cutting conditions vary between cutting the print surface and cutting parts that have not been printed on. When cutting the print surface, use this [Printing for Cutting Test] function to adjust the cutting conditions.

This adjustment is only an estimate. Accuracy is not assured.

Step 1: Perform printing for a cutting test and perform the cutting test.

Procedure

1. Set up the media.
2. Tap .
3. Tap [Media Settings]>[Cutting Settings]>[Blade Adjustment].
4. Tap [Execute] next to [Printing for Cutting Test].

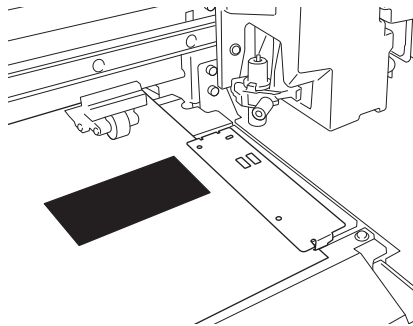

5. Tap [Execute] next to [Cutting Test].

The test pattern is cut.

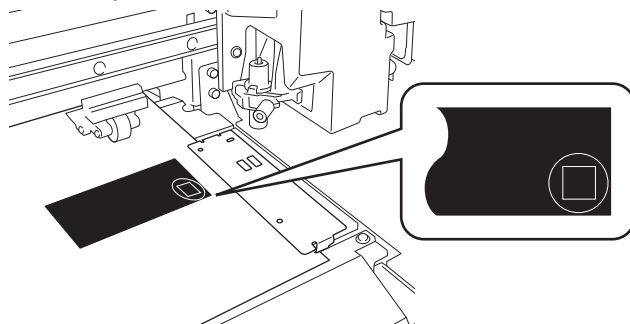



Step 2: Check the results of the cutting test and adjust the cutting conditions.

Procedure

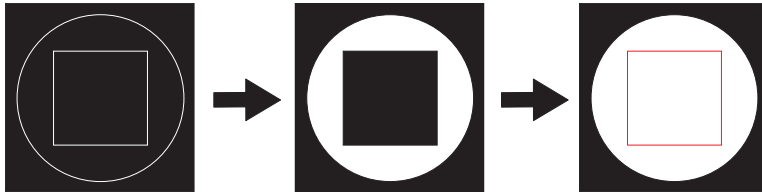
1. Open the front cover.
2. Check the results of the cutting test.



Check item	Result	Setting item	Adjustment
Check the shape.	The cut shape is distorted.	[Cutting Speed]	Reduce
Peel off the circle.	The square also peels off.	[Blade Force]	Increase
	Some uncut areas remain.	[Cutting Speed]	Reduce
Peel off the square.	The blade leaves faint traces on the backing paper.	[Blade Force]	No change
	The blade trace is indistinct.		Increase
	The blade trace is too deep and cuts into the backing paper.		Reduce
Check the shape of the square you have peeled off.	 The corners are not rounded and do not have "horns."	[Blade Offset]	No change
	 The corners are rounded.		Increase
	 The corners have "horns."		Reduce

3. Tap  or  to change the settings.





Display screen (cutting conditions)	Setting details	Default settings
[Blade Force]	Set the force (pressure) of the blade.	50 gf
[Cutting Speed]	Set the speed of cutting.	30 cm/s
[Blade Offset]	Set the blade offset. Enter the listed offset value for the blade. The offset value for the included blade is 0.250 mm (9.8 mil).	0.250 mm (0.010 in.)
[Rise Movement Speed]	Set the blade's up speed during cutting (the speed at which the blade travels when it moves to the next cutting line after cutting one cutting line). If the media comes loose during no-load feed and the blade damages the surface of the media, reduce the speed.	30 cm/s

4. Tap [Save] to confirm your entry.

Step 3: Check the adjustment results.

Procedure

1. Tap [Execute] next to [Output Start Location].

2. Tap , ,  or  to move the center of the blade to the position that you want to set as the base point.

Tap  or  to move the media. Tap  or  to move the cutting carriage.

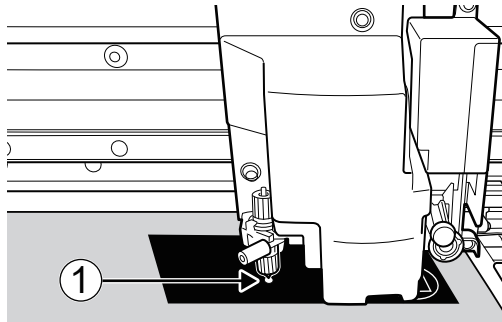

- ①: Base point (right edge of the output area)

3. Once the position has been decided, tap [Set Base Point Here] to confirm it.

4. Close the front cover.

5. Tap [Execute] next to [Cutting Test].

The test pattern is cut.

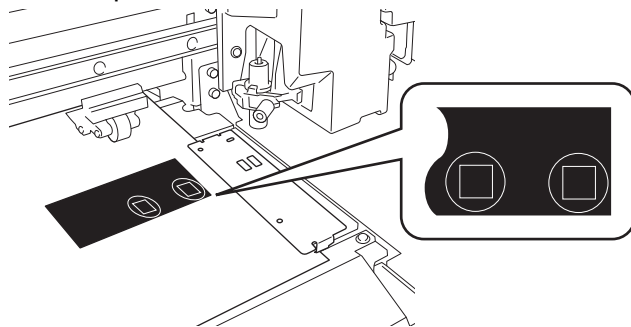

6. Open the front cover.

7. Check the results of the cutting test again.

8. When the correction is finished, tap  to go back to the original screen.

Performing Distance Correction during Cutting

This correction is performed when you want to accurately align the lengths of cut lines when cutting. This setting is applied to both cutting only and printing and cutting.

The movement distance of the media changes subtly depending on the media's thickness. This means that the length of a line when cut may differ from the length setting in the data.

Procedure

1. Set up the media.

2. Tap .

3. Tap [Media Settings]>[Cutting Settings]>[Cutting Distance Correction].

4. Tap  or  to change the correction values.

Setting item	Setting details	Default settings
[Correction Value (Feed)]	Correction value of the media feed direction	0.00%
[Correction Value (Scan)]	Correction value of the print head movement direction	0.00%

5. Tap [Save] to confirm your entry.

6. Tap  to go back to the original screen.



Cutting to Make It Possible to Cut Corners Attractively (Over Cut)

Cutting the corners of the border of the cutting line slightly longer makes it possible to cut the corners attractively.

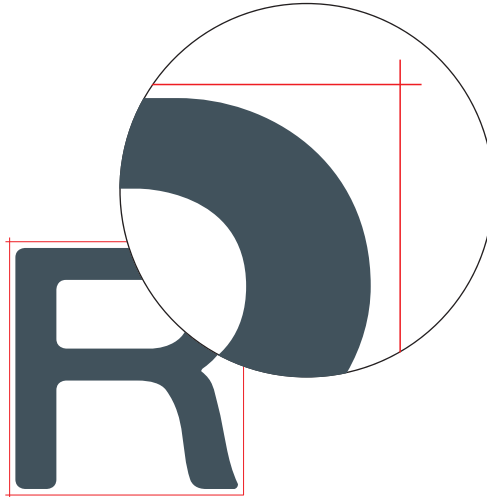
This is effective when using laminated or thick media, or non-resilient media. It also has the effect of making stickers easier to peel off.



Procedure

1. Set up the media.
2. Tap .
3. Tap [Media Settings]>[Cutting Settings]>[Over Cut].
4. Tap [Enable].
5. Tap [Save] to confirm your entry.
6. Tap  to go back to the original screen.

MEMO

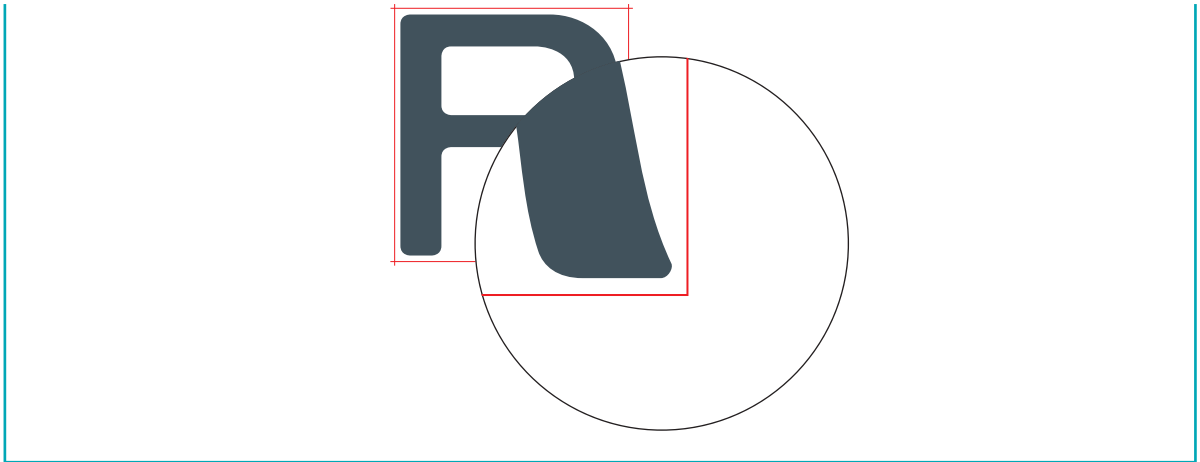

- Default setting: [Disable]
- The cutting start point is not over cut.



Prioritizing the Cutting Settings of This Machine over the Software RIP Settings

This setting is used to prioritize the cutting conditions set on the machine over the software RIP settings. You can also make the settings for the cutting conditions in the software RIP, and normally the software RIP settings are given priority.

Procedure

1. Tap .
2. Tap [Preferences]>[Priority for Cutting Settings].
3. Select [Machine Priority].
4. Tap [Save] to confirm your entry.
5. Tap  to go back to the original screen.

MEMO

- Default setting: [Software RIP Priority]

Accurately Adjusting the Settings for Printing and Cutting

Correcting the Misalignment of Printing and Cutting

This is a correction method performed when printing followed immediately by cutting yields positioning for printing and cutting that is slightly misaligned.

Print alignment marks, perform detection of the printed marks, and then correct the discrepancy. Subtle misalignment between the printing and cutting positions may occur due to the thickness of the media or the head height. We recommend that you make corrections to match the media you are using.

1. Adjust the misalignment of the ink landing position.

Procedure

1. Set up the media.

2. Tap .

3. Tap [Media Settings]>[Printing Settings]>[Media Gap Adjustment].

4. Select [Simple Correction (Auto)] and tap [Next].

5. Tap [Execute].

The test pattern is printed and the media gap is adjusted automatically.

6. Tap [OK] when the completion screen appears.

7. Perform the operations shown below according to the [Result].

- If [Successful] is displayed on the operation panel, tap  to go back to the original screen.
- If [Failed] is displayed on the operation panel, manually adjust the media gap.

RELATED LINKS

- [P. 170 Manual Adjustment: Adjusting the Misalignment of the Ink Landing Position \(Media Gap Adjustment\)](#)

2. Correcting the Misalignment of Printing and Cutting

Procedure

1. Tap .
2. Tap [Media Settings]>[Cutting Settings]>[Print & Cut Position Adjustment].
3. Tap [Execute] next to [Printing Test 1 (Misalignment Check)].
Printing Test 1 is printed and cut. The test pattern is printed at each edge of the media.

MEMO

If the media is tilted, the positions at the edges will be misaligned. You can also adjust for misalignments due to the media being tilted by printing the test pattern at each edge.

4. Check the result of Printing Test 1.

Check whether the printing position (shaded part) and the cutting position (red line) are aligned. An example of the printing position and the cutting position being misaligned is shown in the following figure.

[F] indicates the feed direction of the media (the feed direction) and [S] indicates the direction of print head movement (the scan direction).

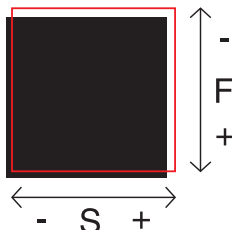

If the printing position and the cutting position are aligned, no corrections are necessary.

If the printing position and the cutting position are not aligned, proceed to the next procedure.

5. Tap [Execute] next to [Printing Test 2 (Correction Values)].

Printing Test 2 is printed and cut.



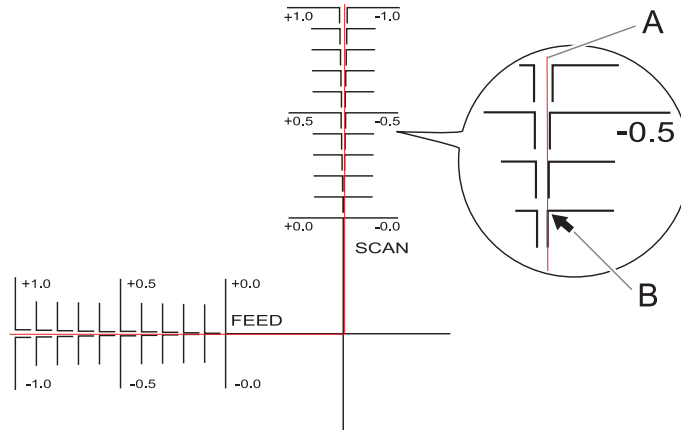

6. Check the correction values from the Printing Test 2 condition.

The point where the cutting line (A) intersects the correction-value scale (B) is the correction value. In the following figure, the correction value is "-0.3."

Check the media feed direction (the feed direction) and the direction of print head movement (the scan direction).





7. Set the correction values in the feed direction of the media (the feed direction) and the direction of print head movement (the scan direction).

- (1) Tap  or  next to [Correction Value (Feed)] to set the correction value in the feed direction of the media (the feed direction).
- (2) Tap  or  next to [Correction Value (Scan)] to set the correction value in the direction of print head movement (the scan direction).

8. Tap [Save].

The correction values are saved.

9. Tap [Execute] next to [Printing Test 1 (Misalignment Check)].

Printing Test 1 is printed and cut. If the printing and cutting lines are aligned, adjustment is complete. If further adjustment is needed, tap  or  next to [Correction Value (Feed)] and [Correction Value (Scan)] to fine-tune the printing and cutting position, and then [Save] the values.

MEMO

Default settings

- [Correction Value (Feed)] (correction value of the media feed direction): 0.00 mm
- [Correction Value (Scan)] (correction value of the print head movement direction): 0.00 mm

10. Tap  to go back to the original screen.

Correcting the Misalignment of the Printing and Cutting Positions during Cutting

This method pauses a cutting operation to correct the misalignment of the cutting positions (A) when this misalignment is found during cutting after printing. The correction values set here are applied to the media settings currently set up.

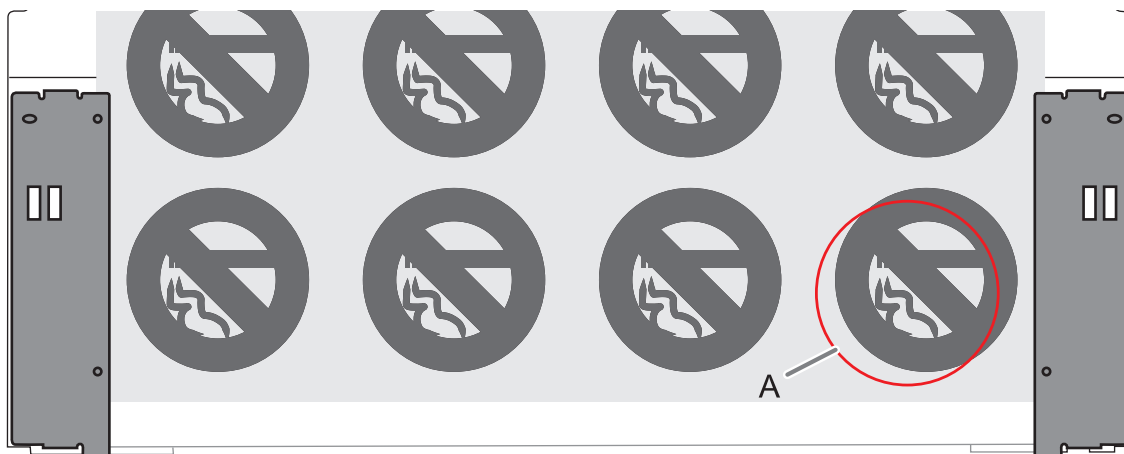

If the printing and cutting positions are misaligned, normally adjust the positions while checking a test pattern.

Procedure

1. During cutting, tap [Pause].
The cutting operation is paused.
2. Tap .
3. Tap [Media Settings]>[Cutting Settings]>[Print & Cut Position Adjustment].
4. Determine the correction value for the cutting position.

MEMO

To decide a correction value

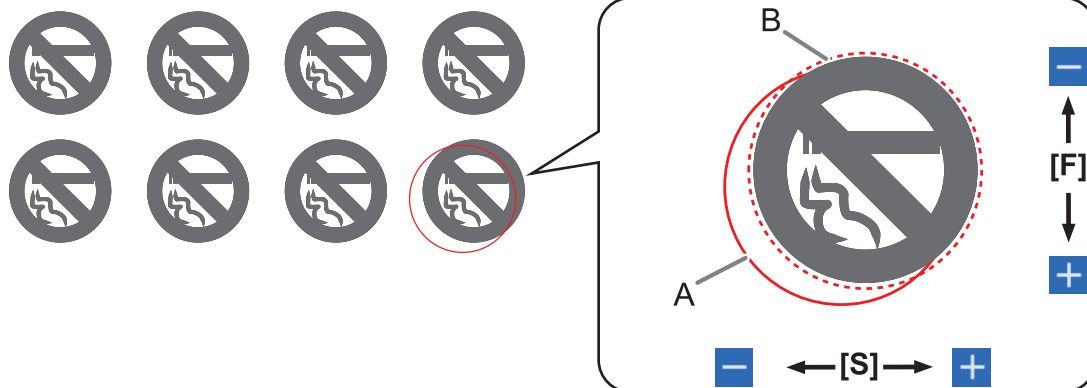

In the following figure, move the solid line (A), representing the current cutting position, to the dashed line (B).





- Media feed direction misaligned in the positive direction

- Move the cutting position in the negative direction.
- Print head movement direction (scan direction) misaligned in the negative direction
- Move the cutting position in the positive direction.

5. Set the correction values in the feed direction of the media (the feed direction) and the direction of print head movement (the scan direction).

(1) Tap  or  next to [Correction Value (Feed)] to set the correction value in the feed direction of the media (the feed direction).

(2) Tap  or  next to [Correction Value (Scan)] to set the correction value in the direction of print head movement (the scan direction).

6. Tap [Save] to confirm your entry.

7. Tap  to go back to the original screen.

8. Tap [Resume] to restart the cutting operation.
Tap [Cancel Output] to cancel the cutting operation.

MEMO

- Default settings
 - [Correction Value (Feed)] (correction value of the media feed direction): 0.00 mm
 - [Correction Value (Scan)] (correction value of the print head movement direction): 0.00 mm

RELATED LINKS

- [P. 193 Correcting the Misalignment of Printing and Cutting](#)

Accurately Adjusting the Settings for Cutting with Crop Marks

Correcting the Misalignment of Printing and Cutting with Crop Marks (Concurrent Test for Printing and Cutting with Crop Marks)

Depending on the composition of the media, the positioning of printing and cutting may be misaligned even when you are using crop marks. Make corrections for misaligned printing and cutting for the media you are using.

In cutting with crop marks, cutting is performed after removing the media after printing. However, with this method, you can make corrections of printing and cutting positions at the same time without removing the media.

1. Adjust the misalignment of the ink landing position.

Procedure

1. Set up the media.

2. Tap .

3. Tap [Media Settings]>[Printing Settings]>[Media Gap Adjustment].

4. Select [Simple Correction (Auto)] and tap [Next].

5. Tap [Execute].

The test pattern is printed and the media gap is adjusted automatically.

6. Tap [OK] when the completion screen appears.

7. Perform the operations shown below according to the [Result].

- If [Successful] is displayed on the operation panel, tap  to go back to the original screen.
- If [Failed] is displayed on the operation panel, manually adjust the media gap.

RELATED LINKS

- [P. 170 Manual Adjustment: Adjusting the Misalignment of the Ink Landing Position \(Media Gap Adjustment\)](#)

2. Correcting the Misalignment of Printing and Cutting with Crop Marks at the Same Time

Use the following procedure to print the crop marks and cut the media, checking for misalignment in the positions. In this section, the crop marks are printed simply, and then the crop marks are read and a cutting test is performed without removing the media. To simulate the actual process—printing crop marks, removing the media, and then performing post-processing such as laminating—before loading the media and checking for cutting position misalignment, turn on **[Separate Test for Printing/Cutting with Crop Marks]**. For more information, refer to [Correcting the Misalignment of Printing and Cutting with Crop Marks \(Separate Test for Printing/Cutting with Crop Marks\)\(P. 201\)](#).

Procedure

1. Tap .

2. Tap **[Media Settings]>[Cutting Settings]>[Crop Cut Position Adjustment]**.

3. Tap **[Execute]** next to **[Printing Test 1 (Misalignment Check)]**.

Printing Test 1 is printed and cut. One test pattern is printed on the media.

4. Check Printing Test 1.

Check whether the printing position (shaded part) and the cutting position (red line) are aligned. An example of the printing position and the cutting position being misaligned is shown in the following figure.

[F] indicates the feed direction of the media (the feed direction) and [S] indicates the direction of print head movement (the scan direction).

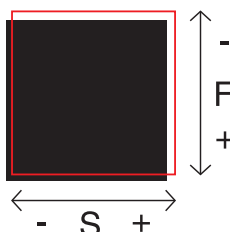

If the printing position and the cutting position are aligned, no corrections are necessary.

If the printing position and the cutting position are not aligned, proceed to the next procedure.

5. Tap **[Execute]** next to **[Printing Test 2 (Correction Values)]**.

Printing Test 2 is printed and cut.



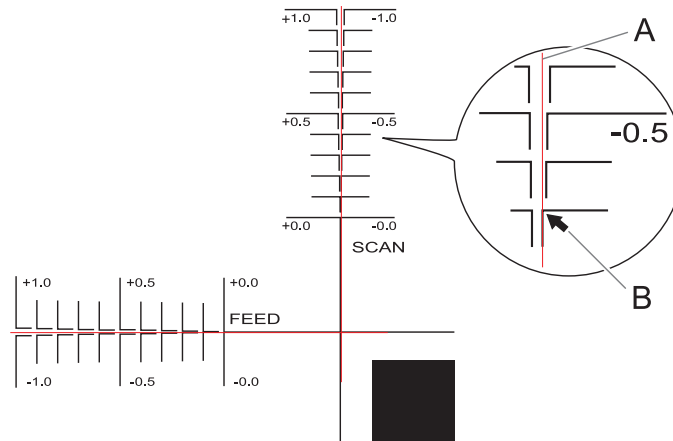

6. Check the correction values from the Printing Test 2 condition.

The point where the cutting line (A) intersects the correction-value scale (B) is the correction value. In the following figure, the correction value is "-0.3."



Check the media feed direction (the feed direction) and the direction of print head movement (the scan direction).



7. Set the correction values in the feed direction of the media (the feed direction) and the direction of print head movement (the scan direction).

- (1) Tap  or  next to [Correction Value (Feed)] to set the correction value in the feed direction of the media (the feed direction).
- (2) Tap  or  next to [Correction Value (Scan)] to set the correction value in the direction of print head movement (the scan direction).

8. Tap [Save].
The correction values are saved.

9. Tap [Execute] next to [Printing Test 1 (Misalignment Check)].
Printing Test 1 is printed and cut. If the printing and cutting lines are aligned, adjustment is complete. If further adjustment is needed, tap  or  next to [Correction Value (Feed)] and [Correction Value (Scan)] to fine-tune the printing and cutting position, and then [Save] the values.

MEMO

- Default settings
 [Correction Value (Feed)] (correction value of the media feed direction): 0.00 mm
 [Correction Value (Scan)] (correction value of the print head movement direction): 0.00 mm
- Depending on the changes in the condition of media caused by laminating and the loading position of the media before cutting, the positioning of cutting may be misaligned. In such cases, correct the misalignment of printing and cutting with crop marks.

10. Tap  to go back to the original screen.

RELATED LINKS

- [P. 201 Correcting the Misalignment of Printing and Cutting with Crop Marks \(Separate Test for Printing/Cutting with Crop Marks\)](#)

Correcting the Misalignment of Printing and Cutting with Crop Marks (Separate Test for Printing/Cutting with Crop Marks)

Due to changes in the thickness of media caused by laminating and misalignment of the loading position of the media before and after cutting, the positioning of printing and cutting may be misaligned even when you are using crop marks. Make corrections for misaligned printing and cutting for the media you are using and its condition.

In this test, so as to create the same conditions as the actual operation, print only the crop marks, remove the media, load the media again, and then cut the media.

1. Adjust the misalignment of the ink landing position.

Procedure

1. Set up the media.

2. Tap .

3. Tap [Media Settings]>[Printing Settings]>[Media Gap Adjustment].

4. Select [Simple Correction (Auto)] and tap [Next].

5. Tap [Execute].

The test pattern is printed and the media gap is adjusted automatically.

6. Tap [OK] when the completion screen appears.

7. Perform the operations shown below according to the [Result].





- If [Successful] is displayed on the operation panel, tap  to go back to the original screen.
- If [Failed] is displayed on the operation panel, manually adjust the media gap.

RELATED LINKS

- [P. 170 Manual Adjustment: Adjusting the Misalignment of the Ink Landing Position \(Media Gap Adjustment\)](#)

2. Print only the crop marks.

Procedure

1. Tap .
2. Tap [Media Settings]>[Cutting Settings]>[Crop Cut Position Adjustment].
3. Tap  next to [Separate Test for Printing/Cutting with Crop Marks] to turn it on .
4. Tap [Execute] next to [Printing Test].
Printing of the test pattern starts.
The crop marks are printed. When printing is finished, you will return to the original screen.
5. Remove any media.
Use the following procedure to separate the media.
 - (1) Close the front cover.
 - (2) Tap [Change] next to [Output Start Location].
 - (3) Tap  to feed the media until there is a margin of 130 mm (5.12 in.) or more after the printed crop marks.
 - (4) Tap  to go back to the previous screen.
 - (5) Tap [Execute] next to [Sheet Cutting].
 - (6) Tap [Yes] on the confirmation screen.
6. Complete operations before cutting output for normal cutting with crop marks, such as laminating.

3. Perform a cutting test.

Procedure

1. Set up the media for which operations before cutting output, such as lamination, is complete.





2. Tap .

3. Tap [Media Settings]>[Cutting Settings]>[Crop Cut Position Adjustment].

4. Tap  next to [Separate Test for Printing/Cutting with Crop Marks] to turn it on .

5. Tap [Execute] next to [Cutting Test].

The [Move the blade over a crop mark.] screen appears.

6. Tap , , , or  to move the center of the blade over the crop marks to use in the cutting test.

The center of the blade should only be over the crop marks, and does not need to be aligned with the center of the crop marks.

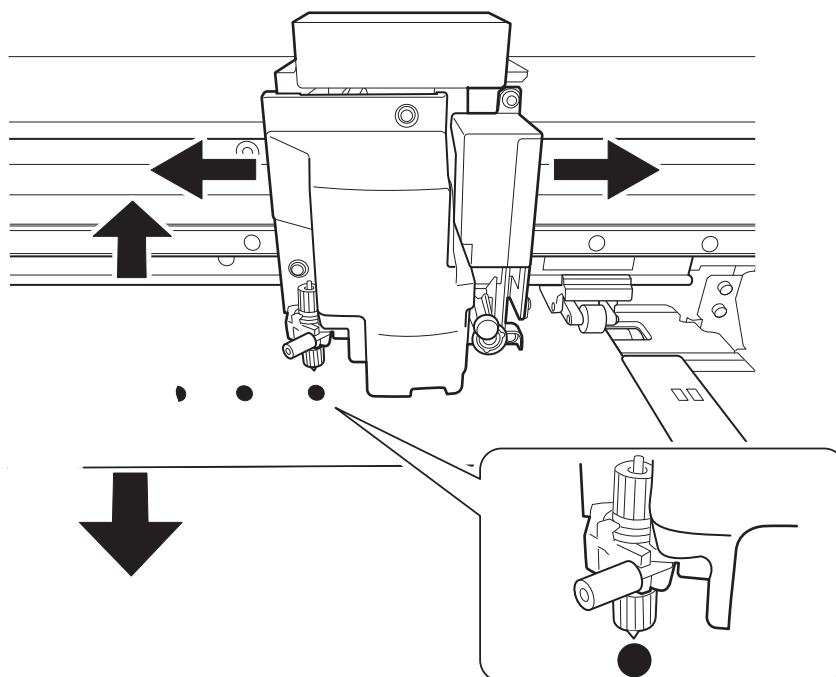

7. Tap [Execute].

The cutting test starts.

4. Set the correction values.

Procedure

1. View the results of the cutting test to determine the correction values.

Check whether the crop mark (shaded part) and the cutting position (red line) are aligned. An example of the crop mark and the cutting position being misaligned is shown in the following figure.

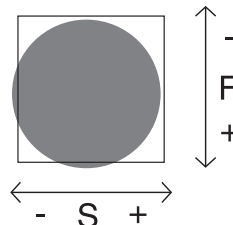



- If the test printed crop marks are inside the cutting line, correction is not necessary.
- If the test printed crop marks are extending beyond the cutting line, correction is necessary.



[F] indicates the feed direction of the media (the feed direction) and [S] indicates the direction of print head movement (the scan direction). ("F," "S," "+," "-", " and the arrows are not displayed on the actual test pattern.)

MEMO

Determine the values so as to correct the misalignment of the cutting position. In the case of the above figure, feed direction [F] is misaligned in a negative direction and scan direction [S] in a positive direction. Therefore, set the correction values for the feed direction [F] to positive values and the scan direction [S] to negative values. Measure the actual misalignment amount when determining the value.

2. Set the correction values in the feed direction of the media (the feed direction) and the direction of print head movement (the scan direction).

(1) Tap  or  next to [Correction Value (Feed)] to set the correction value in the feed direction of the media (the feed direction).

(2) Tap  or  next to [Correction Value (Scan)] to set the correction value in the direction of print head movement (the scan direction).

3. Tap [Save].

4. Perform steps 5 to 7 of 3. **Perform a cutting test.(P. 203)** again to check whether the correction was successful.

- If the test printed crop marks are inside the cutting line, correction is complete.
- If the test printed crop marks are extending beyond the cutting line, redo the correction.

5. Tap  to go back to the original screen.

MEMO

- Default settings
 [Correction Value (Feed)] (correction value of the media feed direction): 0.00 mm
 [Correction Value (Scan)] (correction value of the print head movement direction): 0.00 mm

- You can also make corrections of printing and cutting positions at the same time without removing the media.

RELATED LINKS

- [P. 198 Correcting the Misalignment of Printing and Cutting with Crop Marks \(Concurrent Test for Printing and Cutting with Crop Marks\)](#)

Correcting the Reading Sensor

Depending on the characteristics of the media, such as reflectivity and colors, the machine may not be able to read the crop marks. In such cases, correct the sensor for reading crop marks. If you are not cutting with crop marks, operation is not affected even if a failure is displayed.

Procedure

1. Set up the media.

2. Tap .

3. Tap [Media Settings]>[Other Media Settings]>[Multi Sensor Adjustment].

4. Tap [Execute].

The [Adjustment Result] screen appears.

- [Successful]:

Tap  to go back to the original screen.

- [Failed]:

Check the following items.

Cause	Countermeasures
The lighting in the room where the printer is installed or vicinity of the printer is too bright.	Adjust the lighting in the room.
Correction failed for some reason.	Redo the correction.
Crop marks cannot be recognized due to the characteristics (reflectivity and colors) of the media.	To cut with crop marks, change the media.
There is ink on the multi sensor because, for example, the media strikes it immediately after printing.	Contact your authorized Roland DG Corporation dealer.

Avoiding Printing Cancellation Due to Cleaning

Cleaning during Printing

This machine counts the hours of printing, and when the accumulated printing hours reach a specified time, automatic cleaning is performed. When cleaning finishes, the accumulated printing time is reset. This cleaning can also be performed during printing, so print quality may be affected.

To avoid cleaning during printing, first obtain the time until cleaning is performed. Next, use the software RIP to confirm the required time for printing. If the required time for printing is greater than the time until cleaning, perform Cleaning and Count Clear prior to printing. This will cause the accumulated printing time to be reset. Alternatively, change the print quality to reduce the time required for printing. Either of these methods can be used to prevent cleaning from being performed while printing is in progress.

1. Confirm the accumulated printing time.

If the remaining time until cleaning is performed is not displayed on the home screen, change the settings from the menu to display this time.

[P. 228 Displaying the Remaining Time until Cleaning Is Performed](#)

Procedure

1. If the home screen is not displayed, tap



2. Check the display of [Until CL.].

The remaining time until automatic cleaning is displayed.

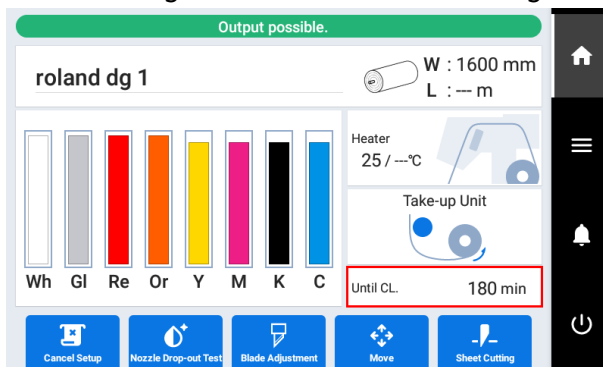

2. Confirm the required time for printing.

Use the software RIP to confirm the required time for printing. The following is the method for confirming when using VersaWorks.

Procedure

1. Display the [Job Settings] window.
2. Confirm the required time for printing.

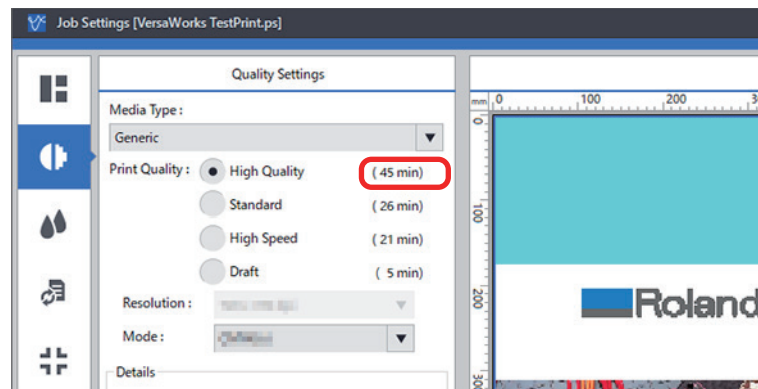

RELATED LINKS

- VersaWorks manual (<https://downloadcenter.rolanddg.com/VersaWorks6>)

3. Reset the time until automatic cleaning.

Check the time until automatic cleaning and the required time for printing and perform Cleaning and Count Clear to reset the accumulated time if necessary.

Procedure

1. Tap .

2. Tap [Preferences]>[Time Remaining before Cleaning during Printing].

The screen shown below appears.

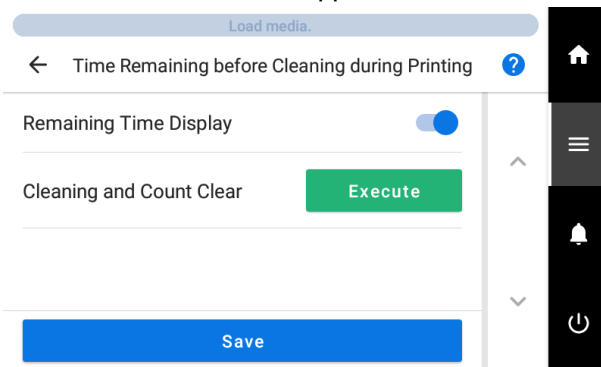

3. Tap [Execute] next to [Cleaning and Count Clear].

Cleaning will start. The status is displayed as [Maintenance in progress.] at the top of the operation panel.

On completion, you will return to the original screen.

4. Tap  to go back to the original screen.

Optimizing Work Efficiency

Managing the Media Settings.....	211
Changing the Media Settings	211
Checking the Registered Media Settings	213
Changing the Media Name	215
Duplicating Media Settings.....	216
Duplicating Media Settings for Cutting.....	217
Deleting Media Settings	218
Adjusting the Output-start Location.....	219
Setting the Base Point	219
Reducing Output Time	221
Speeding Up Output for Narrow Media.....	221
Other Useful Functions	222
Performing Printing Tests Arranged Horizontally	222

Managing the Media Settings

Changing the Media Settings

Use the following procedure to change the media settings. These settings can only be changed for the media being set up.

Procedure

1. Set up the media.
2. Tap .
3. Tap [Media Settings]>[List of Media Settings].
4. Tap the setting to change to move to the screen for editing this setting.

The media settings that can be changed are as follows.

Menu item	Reference page
[Print Head Height]	P. 172 Changing the Print Head Height
[Feed Correction]	P. 168 Manual Adjustment: Reducing Horizontal Bands (Feed Correction)
[Media Gap Adjustment]	P. 170 Manual Adjustment: Adjusting the Misalignment of the Ink Landing Position (Media Gap Adjustment)
[Blade Adjustment]	P. 183 Fine-tuning the Cutting Conditions
[Print & Cut Position Adjustment]	P. 193 Correcting the Misalignment of Printing and Cutting
[Crop Cut Position Adjustment]	P. 198 Correcting the Misalignment of Printing and Cutting with Crop Marks (Concurrent Test for Printing and Cutting with Crop Marks) P. 201 Correcting the Misalignment of Printing and Cutting with Crop Marks (Separate Test for Printing/Cutting with Crop Marks)
[Cutting Distance Correction]	P. 189 Performing Distance Correction during Cutting
[Over Cut]	P. 190 Cutting to Make It Possible to Cut Corners Attractively (Over Cut)
[Heater Temperature]	P. 179 Setting the Standby Heater Temperature P. 181 Setting the Output Heater Temperature
[Multi Sensor Adjustment]	P. 206 Correcting the Reading Sensor
[Media Suction Force]	P. 174 Using Media That Wrinkles Easily/ Does Not Move Smoothly
[Printing Movement Range]	P. 221 Speeding Up Output for Narrow Media

Managing the Media Settings

Menu item	Reference page
[Middle Pinch Auto Raise/Lower]	P. 177 Use Middle Pinch Rollers When Pulling Back or Feeding Media

5. If you have changed a setting, tap [Save].

6. Tap  to go back to the original screen.

Checking the Registered Media Settings

Procedure



1. Tap .
2. Tap [Media Management].
The registered media settings are displayed in a list.
3. Tap a media setting.
4. Tap [List of Media Settings].
The registered media setting values are displayed in a list.

Menu item	Reference page
[Print Head Height]	P. 172 Changing the Print Head Height
[Feed Correction]	P. 168 Manual Adjustment: Reducing Horizontal Bands (Feed Correction)
[Media Gap Adjustment]	P. 170 Manual Adjustment: Adjusting the Misalignment of the Ink Landing Position (Media Gap Adjustment)
[Blade Adjustment]	P. 183 Fine-tuning the Cutting Conditions
[Print & Cut Position Adjustment]	P. 193 Correcting the Misalignment of Printing and Cutting
[Crop Cut Position Adjustment]	P. 198 Correcting the Misalignment of Printing and Cutting with Crop Marks (Concurrent Test for Printing and Cutting with Crop Marks) P. 201 Correcting the Misalignment of Printing and Cutting with Crop Marks (Separate Test for Printing/Cutting with Crop Marks)
[Cutting Distance Correction]	P. 189 Performing Distance Correction during Cutting
[Over Cut]	P. 190 Cutting to Make It Possible to Cut Corners Attractively (Over Cut)
[Heater Temperature]	P. 179 Setting the Standby Heater Temperature P. 181 Setting the Output Heater Temperature
[Multi Sensor Adjustment]	P. 206 Correcting the Reading Sensor
[Media Suction Force]	P. 174 Using Media That Wrinkles Easily/ Does Not Move Smoothly
[Printing Movement Range]	P. 221 Speeding Up Output for Narrow Media
[Middle Pinch Auto Raise/Lower]	P. 177 Use Middle Pinch Rollers When Pulling Back or Feeding Media

5. Tap  to go back to the original screen.

Changing the Media Name



Procedure

1. Tap .
2. Tap [Media Management].
The registered media settings are displayed in a list.
3. Tap the media whose name you want to change.
4. Tap .
5. Tap the input field and enter the media name.
You can use up to 15 alphanumeric characters.
6. Tap [OK] to confirm your entry.
7. Tap  to go back to the original screen.

Duplicating Media Settings

Use the following procedure to duplicate existing media settings.



Procedure

1. Tap .
2. Tap [Media Management].
The registered media settings are displayed in a list.
3. Tap the media setting to duplicate.
4. Tap [Duplicate Media].
A screen for entering the name of the duplicated media appears. To create this name, [COPY] is added at the start of the name of the media being duplicated.
5. Enter the media name and tap [OK].
6. Tap  to go back to the original screen.

Duplicating Media Settings for Cutting

Use the following procedure to duplicate existing media settings for cutting.

Procedure

1. Tap .
2. Tap [Media Management].
The registered media settings are displayed in a list.
3. Tap the media setting to duplicate.
4. Tap [Duplicate as Media for Cutting].
 - A screen for entering the name of the duplicated media appears. To create this name, [COPY] is added at the start of the name of the media being duplicated.
 - The media setting is duplicated with the settings configured so the heater power is off.
5. Enter the media name and tap [OK].
6. Tap  to go back to the original screen.



Deleting Media Settings

Use the following procedure to delete existing media settings.

MEMO

This operation cannot be performed on the media being set up. To perform this operation, first cancel media setup.

Procedure

1. Tap .
2. Tap [Media Management].
The registered media settings are displayed in a list.
3. Tap the media to be deleted.
4. Tap [Delete Media].
5. Tap [Yes] when the confirmation screen appears.
The media settings are deleted, and you are returned to the screen listing the registered media settings.
6. Tap  to go back to the original screen.

Adjusting the Output-start Location

Setting the Base Point

Set the base point in order to determine the area on the loaded media in which to print (the output area).

The base point (④) indicates the right edge of the output area (①). (②: Media feed direction, ③: print-head carriage movement direction) You can print without setting the base point, but setting the output area enables you to use media without being wasteful and also to print on the targeted location.

Set the base point for each individual page. When the printing of one page finishes, the base point returns to its default value.

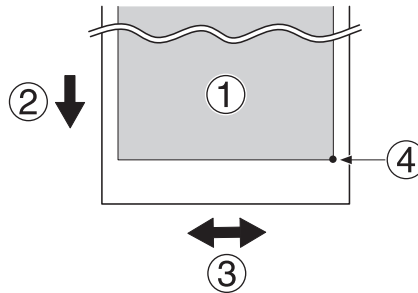

MEMO





- Note that the left and right positions are not restored to their defaults for test patterns.

Procedure

1. Set up the media.

2. Tap  [Move].

The movement screen appears.

3. Tap , ,  or  to move the center of the blade to the position that you want to set as the base point.

Tap  or  to move the media. Tap  or  to move the cutting carriage.

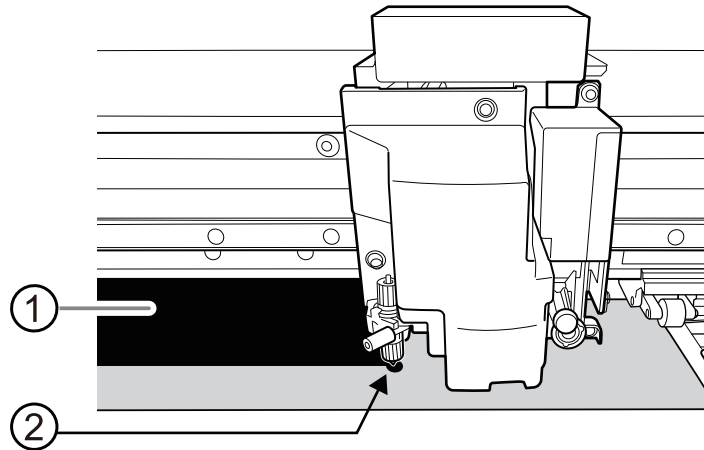

- ①: Output area
- ②: Base point (right edge of the output area)

4. Once the position has been decided, tap [Set Base Point Here] to confirm it.
The base point position is updated, and you are returned to the home screen.

MEMO

The display of the icon on the home screen changes to indicate that the base point position has been updated.

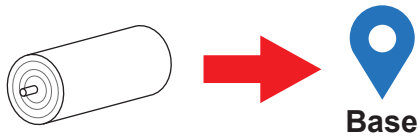

Reducing Output Time

Speeding Up Output for Narrow Media

This shortens output time by reducing the width of head movement to the minimum necessary. This is effective when the width of the media or the output data is narrow.

Procedure

1. Set up the media.
2. Tap .
3. Tap [Media Settings]>[Other Media Settings]>[Printing Movement Range].
4. Specify the range of print head movement during printing.

[Output Data Width]	Matches the range of print head movement to the output data. Movement is limited to the minimum amount necessary, and this can be expected to yield the fastest output. Note, however, that because the speed of media movement is no longer constant, colors may be uneven.
[Media Width]	Matches the range of print head movement to the width of the media.
[Full Width]	The print heads move from one end of the machine to the other. Makes the speed of media movement constant at all times and produces the most stable printing result.

5. Tap [Save] to confirm your entry.
6. Tap  to go back to the original screen.

MEMO



- Default setting: [Output Data Width]

Other Useful Functions

Performing Printing Tests Arranged Horizontally

When performing printing tests successively, you can select [Feed] (vertical printing) or [Scan] (horizontal printing) as the print position for the second and later tests in comparison to the first test.

Procedure

1. Tap .
2. Tap [Preferences]>[Printing Test Position].
3. Select [Scan].
4. Tap [Save] to confirm your entry.
5. Tap  to go back to the original screen.

MEMO

Default setting: [Feed]

Optimizing Operation Management





Managing the Operations Appropriately and Efficiently	224
Setting the Current Date/Time and Using It for Maintenance.....	224
Checking the Remaining Media.....	225
Showing/Hiding Notifications	227
Displaying the Remaining Time until Cleaning Is Performed.....	228
Setting the Activation Interval for Sleep Mode (Power-saving Feature)	230
Managing the Basic Settings of the Printer	231
Changing the Display Language	231
Changing the Units of Measurement	232
Viewing Printer Information	233
Viewing Network Information	234
Adjusting the Brightness of the Operation Panel.....	235
Turning Off Operation Panel Sounds.....	236
Returning All Settings to Factory Defaults	237

Managing the Operations Appropriately and Efficiently

Setting the Current Date/Time and Using It for Maintenance

Use the following procedure to set the current date and time. By setting this, when you perform a printing test the printing test date and time will be printed alongside the printed test pattern.

Procedure

1. Tap .
2. Tap [System Information]>[Date/Time].
3. Tap  or  to set the date and time.
4. Tap [Save] to confirm your entry.
5. Tap  to go back to the original screen.

Checking the Remaining Media

You can display how much of the media in use is left. By setting the amount of media currently remaining at the start, the amount remaining will be constantly displayed on the screen until it reaches zero.

Because the amount of media remaining is not updated automatically when you change the media, redo the setting whenever you change the media.

MEMO



The remaining amount that is displayed is only an estimate. Accuracy is not assured.

Procedure

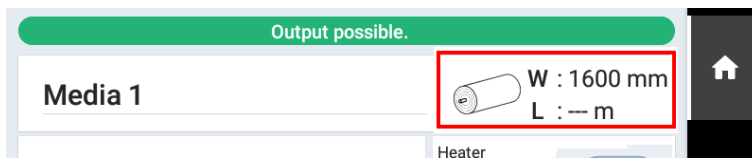
1. Set up the media.
2. Tap the following location on the home screen.



The [Remaining Media Management] screen appears.

3. Tap  or  to enter the length of the remaining media.
4. Tap [Save] to confirm your entry.
5. Tap  to go back to the original screen.

The remaining media is displayed.

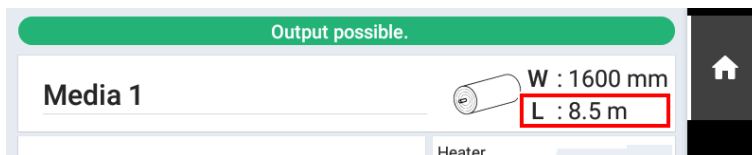

Printing the Amount of Remaining Media

Print the amount of remaining media, which is displayed on the home screen.

Use this when you want to make a record of the remaining length of the media currently in use. Printing the amount of media remaining before you change the media enables you to refer to the printed record and use the value to make the setting for the remaining amount the next time you use the media.

Note, however, that if you continue printing, the next printing operation will start on top of the portion where the amount of remaining media is printed. If you want to continue printing, separate the media before starting the next printing operation.

Procedure

1. Check that the amount of remaining media is displayed on the home screen.
If it is not, set the amount of remaining media by referring to [Checking the Remaining Media\(P. 225\)](#).

2. Tap the following location on the home screen.

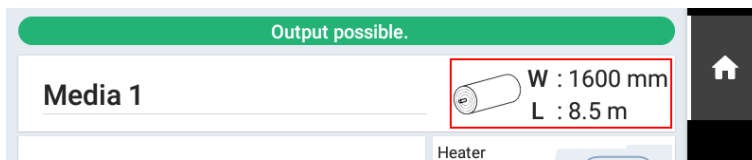

The [Remaining Media Management] screen appears.

3. Tap [Printing Remaining Media Amount]>[Execute].
The amount of remaining media is printed.

Showing/Hiding Notifications

Use the following procedure to show/hide the following notifications, which prompt operators to perform proper operations.

Procedure

1. Tap .

2. Tap [Preferences]>[Notifications On/Off].

3. Tap  to show/hide the notifications.

	Displayed notification	Description
[Ink Mixing Notification]	[The time for ink mixing has arrived.]	Prompts you to mix the ink in the ink pouch tray to prevent ink precipitation. When enabled, a message recommending mixing the ink is displayed once a day.
[Middle Pinch Roller Placement Notification]	[Place the middle pinch rollers over all the grit rollers.]	Prompts you to use the middle pinch rollers, improving media feeding accuracy and preventing the media from coming loose. When enabled, this message appears when the middle pinch rollers have not been placed.
[Media Clamp Placement Notification]	[Install the media clamps correctly.]	Prompts you to correctly place the media clamps to prevent the media from coming loose. When enabled, this message appears when the media clamps are not placed at the edges of the media.
	[Media clamps could not be detected.]	This message appears when the media clamps cannot be detected because they are hidden by the media or are dirty with, for example, ink.
[Ink Expiration Date Notification]	[There is ink that has expired.]	The ink is approaching its expiration date before which the ink must be replaced. P. 114 Ink Replacement Method

4. Tap [Save] to confirm your entry.

5. Tap  to go back to the original screen.

MEMO

Default setting:

- [Ink Mixing Notification]: On
- [Middle Pinch Roller Placement Notification]: On
- [Media Clamp Placement Notification]: On
- [Ink Expiration Date Notification]: On

Displaying the Remaining Time until Cleaning Is Performed

You can display the remaining time until cleaning is performed automatically.



If you turn on the remaining time display, the Cleaning and Clear Count menu will be displayed and the remaining time until cleaning is performed will be displayed on the home screen.

MEMO

Changing the print head height will change the remaining time until cleaning is performed.

As the distance between the media and the print heads increases, the likelihood of ink mist increases, so the remaining time until cleaning is performed shortens.

Procedure

1. Tap .
2. Tap [Preferences]>[Time Remaining before Cleaning during Printing].
3. Tap  to turn [Remaining Time Display] on ().

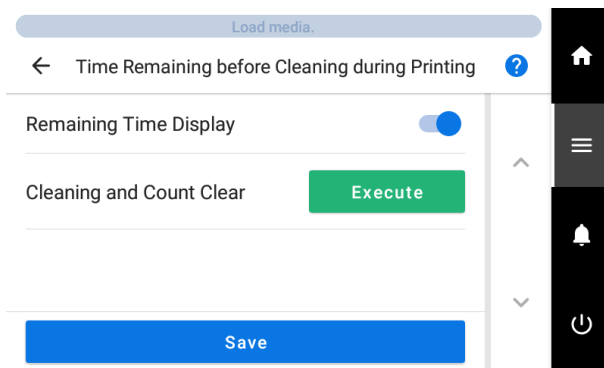

4. Tap [Save] to confirm your entry.
5. Tap  to go back to the original screen.

The remaining [Until CL.] time is displayed on the home screen.

MEMO

Tap the remaining [Until CL.] time to open the settings screen.

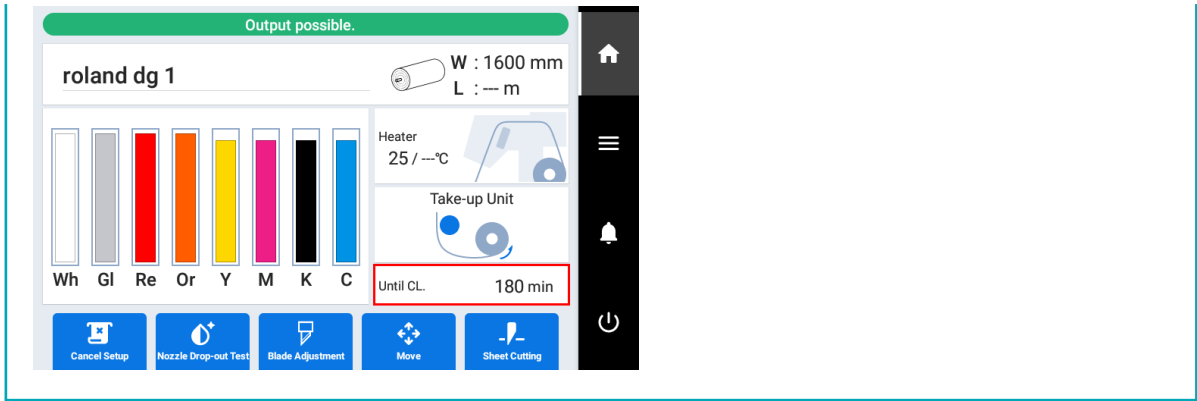





MEMO

- Default setting: Off

Setting the Activation Interval for Sleep Mode (Power-saving Feature)

This setting is used to set how long it should take until the machine goes into sleep mode (the state in which the power-saving feature is working) when no output data is received and no operations are performed for a continued length of time.

Procedure

1. Tap .
2. Tap [Preferences]>[Sleep Time].
3. Tap  or  to set the time.
4. Tap [Save] to confirm your entry.
5. Tap  to go back to the original screen.

MEMO

- Default setting: [30 min.]

Managing the Basic Settings of the Printer

Changing the Display Language

This feature sets the language displayed on the display screen of the operation panel.

Procedure

1. Tap .
2. Tap [System Information]>[Language].
3. Tap [Language].
4. Select the display language.
5. Tap [OK].
6. Tap [Save] to confirm your entry.
The display language is changed, and you are returned to the home screen.

MEMO



Default settings

- [Language]: ENGLISH

Changing the Units of Measurement

Use the following procedure to set the units of measurement displayed on the display screen of the operation panel.

Procedure

1. Tap .
2. Tap [System Information]>[Units].
3. Tap [Length].
4. Select the unit.
5. Tap [Save] to confirm your entry.
6. Tap [Temperature].
7. Select the unit.
8. Tap [Save] to confirm your entry.
9. Tap  to go back to the original screen.



MEMO

- Default settings
 - [Length]: mm
 - [Temperature]: °C

Viewing Printer Information

This is a method for viewing information of this machine, such as serial number and ink type.



Procedure

1. Tap .
2. Tap [System Information]>[Machine Information].
You can check the following information:
 - [Model]: Model name
 - [Serial Number]: Serial number
 - [Ink Type]: Ink type
 - [Firmware Version]
 - [MAC Address]
3. Tap  to go back to the original screen.

Viewing Network Information

Use the following procedure to view network information such as the IP address and default gateway.

Procedure

1. Tap .
2. Tap [System Information]>[Network].
You can check the following information:
 - [Obtain IP Address Automatically]: Enables/disables the automatic obtaining of IP addresses via DHCP. When this is disabled, tap  to change the following settings.
 - [IP Address]
 - [Subnet Mask]
 - [Default Gateway]
3. Tap  to go back to the original screen.

MEMO





- For information on how to set up a network, see the "Setup Guide."

RELATED LINKS

- [LG-640/540/300 Setup Guide](#)

Adjusting the Brightness of the Operation Panel

Procedure

1. Tap .
2. Tap [System Information]>[Screen Brightness].
3. Tap  or  to adjust the brightness.
The larger the value, the brighter the screen.
4. Tap [Save] to confirm your entry.
5. Tap  to go back to the original screen.



MEMO

- Default setting: [50%RH]

Turning Off Operation Panel Sounds

Use the following procedure to turn off the sound when you tap the operation panel.

Procedure

1. Tap .
2. Tap [System Information]>[Screen Operation Sound].
3. Tap [Off].
The operation sound turns off.
4. Tap [Save] to confirm your entry.
5. Tap  to go back to the original screen.

MEMO



- Default setting: [On]

Returning All Settings to Factory Defaults

This menu returns all settings to the same as their factory defaults.

The settings for [Language] and [Units] are not returned to their factory default values.

Procedure

1. Tap .
2. Tap [Preferences]>[Reset to Factory Defaults].
3. Tap [Reset].
4. Tap [Yes] on the confirmation screen.
5. Tap  to go back to the original screen.

Maintenance

Introduction

Important Notes on Handling and Use	240
Printer	240
Ink Cartridges	240
Basic Maintenance Knowledge	241
Types and Timing of Maintenance	241
Measures When the Printer Is Not in Use for a Prolonged Period	243

Important Notes on Handling and Use

Printer

- **This machine is a precision device.**
 - Never subject the machine to impacts or excessive force.
 - Never needlessly put your hand or fingers inside the cover, the ink-cartridge ports, or other internal areas of the machine.
- **Install in a suitable location.**
 - Install the machine in a location having the specified temperature and relative humidity.
 - Install the machine in a quiet, stable location offering good operating conditions.
- **The print heads and the UV-LED device are delicate devices.**
 - Never needlessly touch or allow the object to be printed on to scrape them. Failure to handle with care may cause damage.
 - The print heads may be damaged if allowed to dry out. The machine prevents desiccation automatically, but improper operation may render this feature inoperative. Operate properly, as specified in this manual.
 - Never leave the machine with an ink cartridge removed. Remaining ink in the printer may harden and clog the print heads.
 - Daily maintenance as well as various types of maintenance depending on the status must be performed. Read this manual thoroughly and perform the appropriate maintenance at the appropriate times.
 - The print heads are components that wear out. Periodic replacement is required, with the frequency of replacement depending on use.
- **Keep the operation panel clean.**
 - If dirt or ink adheres to the operation panel, immediately wipe it clean with dry, soft fabric.

Ink Cartridges

- **The ink pouches inside ink cartridges come in various types.**
 - Use a type that is compatible with the printer. Also, be sure to use only genuine items from Roland DG Corporation.
- **Never subject ink cartridges and ink pouches to impacts and never attempt to disassemble ink pouches.**
 - Never drop the ink cartridges or shake them forcefully. The impact may rupture the internal pouches and cause the ink to leak.
 - Never attempt to disassemble ink pouches.
 - Never attempt to refill the ink in ink pouches.
 - If ink gets on your hands or clothing, wash it off as soon as possible. Removal may become difficult if allowed to stand.
- **Storage**
 - Use up the ink before the expiration date printed on the ink pouch.
 - Store the ink cartridge in a location that is not subject to direct sunlight or strong illumination.
 - Store the ink cartridges unopened in a well-ventilated location at a temperature of 5°C (41°F) or higher and less than 30°C (86°F) and a relative humidity of 20%RH to 80%RH.

Basic Maintenance Knowledge

Types and Timing of Maintenance

To use this machine under its optimal conditions, it is important to perform the appropriate maintenance at the appropriate times.

Regular Maintenance

These are the maintenance items that are required on a daily basis.

Timing	Category	Item
Before daily operations	Print head check	P. 132 Performing a Nozzle Drop-out Test
	Ink mixing (white ink)	P. 106 Preventing Sedimentation in Inks
After daily operations	Cleaning the machine	P. 246 Cleaning the Media Path
		P. 247 Cleaning the Cutting Carriage Roller
If a message appears	Cleaning around the print heads	P. 248 Cleaning around the Print Heads
When the discharged fluid is ready to overflow	Disposing of discharged fluid	P. 262 If the Discharged Fluid Disposal Message Appears
Once a month	Cleaning the UV-LED devices	P. 256 Cleaning That Must Be Performed Once a Month or More

Advanced Maintenance

Maintenance that is performed in an emergency. Some of this maintenance consumes a large amount of ink, so thoroughly read the explanation, and then perform the operation at the appropriate point in time.

Timing	Category	Item
When dot drop-out or dot displacement occurs	Checking and cleaning the print heads	P. 132 Performing a Nozzle Drop-out Test
		P. 134 Normal Cleaning Method
		P. 267 Medium Cleaning Method
		P. 269 Powerful Cleaning Method
		P. 126 Manual Cleaning Method
When uneven colors with white ink are not resolved	Circulating the ink and replacing the ink in the ink path ^{*1}	P. 271 Ink Circulating Method
		P. 272 Method for Eliminating Uneven Color Issues with Powerful Cleaning
		P. 273 Method for Ink Renewal Inside Damper
When uneven color, dot drop-out, and dot displacement issues are not resolved even by performing the above operations	Replacing the ink in all ink paths ^{*1}	P. 276 Ink Renewal Method
When the operation panel is dirty	Cleaning the operation panel	P. 285 Operation Panel Cleaning Method

*1 Ink Renewal Inside Damper is cleaning that consumes a large amount of ink.

Replacing Consumable Parts

These items are for replacement of consumable parts. Thoroughly read the explanation, and then perform the operation at the appropriate point in time.

Timing	Category	Item
When a message appears	Replacing consumable parts <ul style="list-style-type: none">• Wiper• Wiper cleaner• UV mist filters• Flushing sponge• Print head caps	P. 287 Replacing the Wiper
		P. 294 Replacing the UV Mist Filters
		P. 296 Replacing the Flushing Sponge
		P. 290 Replacing the Print Head Caps
When a cutting edge becomes dull	Replacing consumable parts <ul style="list-style-type: none">• Blade• Separating knife	P. 298 Replacing the Blade
		P. 304 Replacing the Separating Knife

Measures When the Printer Is Not in Use for a Prolonged Period

Be sure to follow the instructions shown below when the printer is not in use for a prolonged period.

- Empty the drain bottle.

If you know that you will not use the machine for a prolonged period, empty the drain bottle. When the main power is on, the machine periodically performs automatic maintenance in which fluid is discharged.

The drain bottle is filled when the following periods elapse, so periodically discard the discharged fluid.

- Approximately 1 week after the message [**When output, cleaning, and other operations are completed, discard the discharged fluid.**] is displayed or approximately 120 days after the drain bottle is emptied

[P. 262 If the Discharged Fluid Disposal Message Appears](#)

- Do not allow the machine to run out of ink or cleaning liquid.

The machine discharges ink and cleaning liquid during the automatic maintenance that is performed periodically. Set in the machine ink and cleaning liquid pouches having sufficient remaining ink and cleaning liquid. The machine cannot perform automatic maintenance if it has run out of ink or cleaning liquid.

- Switch on the sub power once a month.

Switch on the sub power once a month. When you turn on the power, the machine automatically performs operations such as those to keep the print heads from drying out. Leaving the machine unused for a prolonged period may damage the print heads, so be sure to switch on the power to perform these automatic operations.

- Keep the machine at a constant temperature and relative humidity.

Even when the machine is not in use, keep it at a temperature of 5 to 40°C (41 to 104°F) and a relative humidity of 20 to 80% (with no condensation). Temperatures that are too high may degrade the ink and cause malfunctions. Temperatures that are too low may cause the ink to freeze and damage the print heads.

RELATED LINKS

- [P. 114 Ink Replacement Method](#)
- [P. 120 Cleaning Liquid Replacement Method](#)

Regular Maintenance

Print Head Check before Printing	245
Performing a Nozzle Drop-out Test	245
Cleaning the Machine	246
Cleaning the Media Path	246
Cleaning the Cutting Carriage Roller	247
Cleaning around the Print Heads	248
Manual Cleaning Method	249
Consumable Products and Parts Related to Manual Cleaning.....	255
Cleaning That Must Be Performed Once a Month or More	256
When UV-LED Device Cleaning Is Necessary	256
How to Clean the UV-LED Devices	257

Print Head Check before Printing

Performing a Nozzle Drop-out Test

Before you carry out actual printing, perform a printing test to ensure no dot drop-out or dot displacement occurs. If dot drop-out or dot displacement occurs, perform cleaning of the print heads (normal cleaning).

MEMO

When performing printing tests successively, you can select **[Feed]** (vertical printing) or **[Scan]** (horizontal printing) as the printing position for the second and later tests in comparison to the first test.

[P. 222 Performing Printing Tests Arranged Horizontally](#)

Procedure

1. Set up the media.
2. Tap  **[Nozzle Drop-out Test]** on the home screen.
3. Tap **[Execute]** next to **[Printing Test]**.
Printing of the test pattern starts.

MEMO

Depending on the color of the media used, it may be difficult to check the white ink test pattern.

Tap  **[Nozzle Drop-out Test]** on the home screen, and then select **[Cleaning]>[Printing Test]>[Nozzle Drop-out Test (Base: Black)]** to make the base of the white ink black, making it easier to check the white ink. **[Nozzle Drop-out Test (Base: Black)]** is not displayed if the machine is not equipped with white ink.

4. Check whether there is dot drop-out or dot displacement in the test pattern.
Missing blocks indicate dot drop-out. Collapsed or inclined blocks indicate dot displacement.

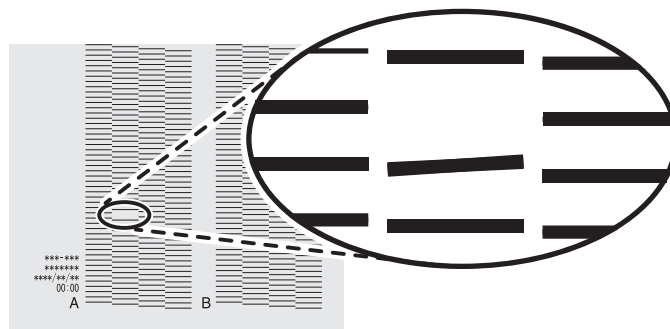

5. If you have opened the front cover, close it.
If no dot drop-out or dot displacement occurs, preparations for output are finished.

RELATED LINKS

- [P. 265 When Dot Drop-out or Dot Displacement Occurs](#)

Cleaning the Machine

Cleaning the Media Path

Wipe away any ink or grime on the media path and other areas as part of the daily cleaning procedure. It is easy for ink or grime to affix to the media path, and, if left unattended, this will contaminate new media and have a negative effect on the transport of media when it is output. Pinch rollers, grit rollers, and the platen are particularly prone to the buildup of grime.

⚠ WARNING

Never use a solvent such as gasoline, alcohol, or thinner to perform cleaning.
Doing so may cause a fire.

⚠ CAUTION

Before attempting cleaning, switch off the sub power and wait until the heater cools (approximately 30 minutes).

Sudden movement of the machine may cause injury, or hot components may cause burns.

IMPORTANT

- This machine is a precision device and is sensitive to dust and dirt. Perform cleaning on a daily basis.
- Never attempt to oil or lubricate the machine.

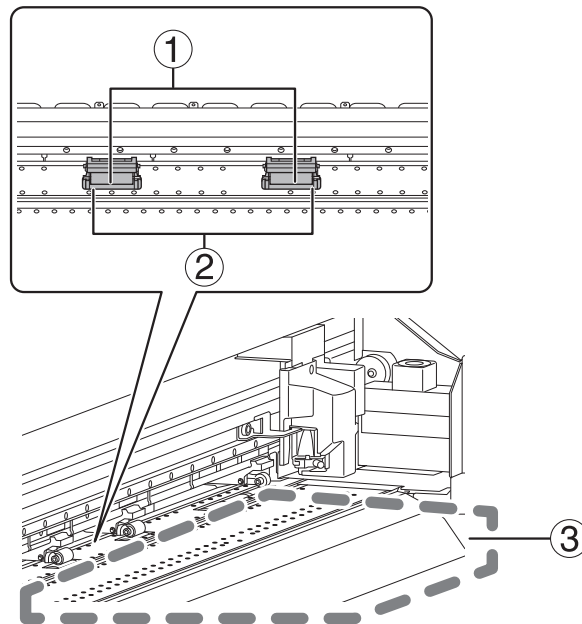

Clean by wiping with a cloth moistened by neutral detergent diluted with water then wrung dry.

①	Pinch roller	These are the positions where the media is fixed in place or transported, so it is easy for ink and grime to affix to these positions. Failure to clean this part properly may result in the transfer of grime to the surface of media.
②	Grit roller	These are the positions where the media is fixed in place or transported, so it is easy for grime to affix to these positions. Remove buildup of media scraps and other material using a brush. Never use a metal brush.
③	Platen	Wipe away any buildup of ink, grime, or cut media on the media path and in the grooves.

Cleaning the Cutting Carriage Roller

Paper dust affixes to the separating knife carriage roller during media separation. Periodically wipe the area clean.

⚠ WARNING

Never use a solvent such as gasoline, alcohol, or thinner to perform cleaning.
Doing so may cause a fire.

⚠ CAUTION

Before attempting cleaning, switch off the sub power and wait until the heater cools (approximately 30 minutes).

Sudden movement of the machine may cause injury, or hot components may cause burns.

IMPORTANT

- This machine is a precision device and is sensitive to dust and dirt. Perform cleaning on a daily basis.
- Never attempt to oil or lubricate the machine.

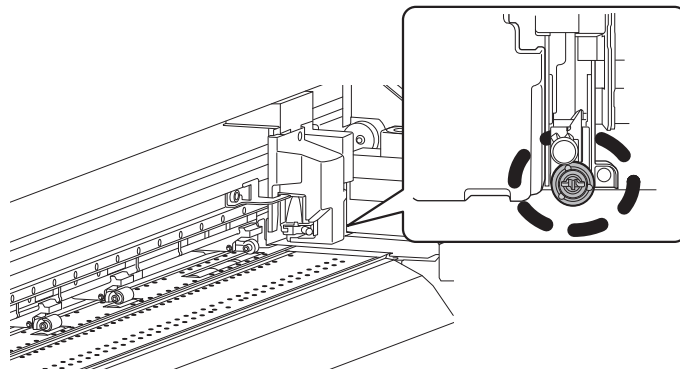

Clean by wiping with a cloth moistened by neutral detergent diluted with water then wrung dry.

Cleaning around the Print Heads

The print heads are important components that discharge ink. They require periodic and appropriate maintenance. Cleaning around the print heads is known as "manual cleaning." Be sure to perform manual cleaning in the following situations.

When a Message Appears

When a message appears, you can tap  on the home screen to check the notification details. Tap the notification to display the manual cleaning menu screen.

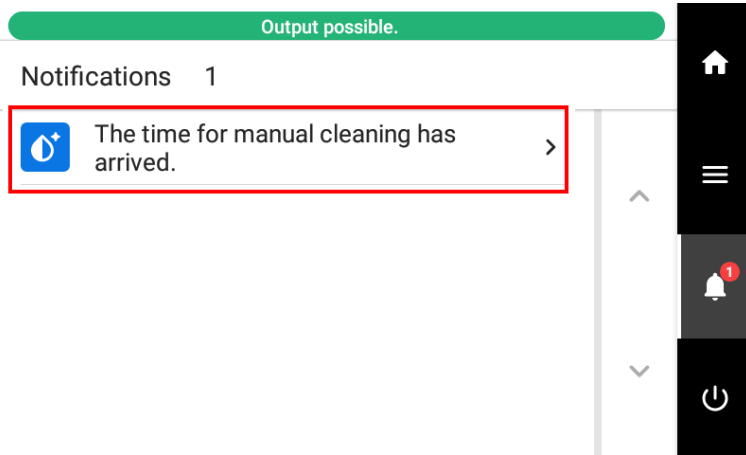

When Symptoms That Cannot Be Improved with Powerful Cleaning Occur

When any of the symptoms given below occur and powerful cleaning is not effective, perform manual cleaning.

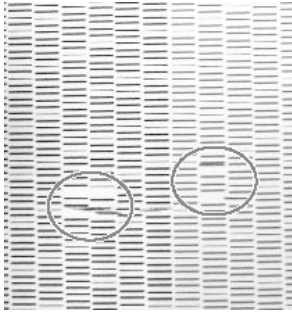
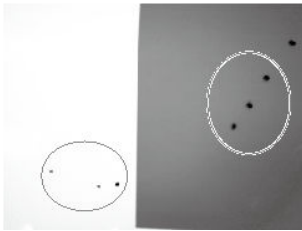
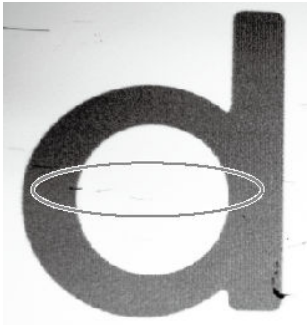
Dot drop-out/Dot displacement	Ink drips	Dragging dirt
		
Dust or other foreign matter adheres to the print heads and impedes correct ink discharge.	Ink pools in dust or dirt adhered to the print heads, and drips onto the media.	The phenomenon where dirt or dust accumulates on the print heads.

MEMO

Wiper replacement may also be effective in improving these symptoms.

RELATED LINKS

- [P. 287 Replacing the Wiper](#)

Manual Cleaning Method

Perform manual cleaning:

- Before daily operations
- When the notification [The time for manual cleaning has arrived.] appears.
- Before sending the print data if you want to perform unmanned printing at night.
- When dot drop-out or ink drip issues that cannot be improved with powerful cleaning occur.

⚠ CAUTION

Do not perform cleaning immediately after printing has finished. (Wait approximately 15 minutes after printing finishes.)

The area around the UV-LED device is hot and may cause burns.

⚠ WARNING

Be sure to perform operations as specified by the instructions, and never touch any area not specified in the instructions.

Sudden movement of the machine may cause injury.



IMPORTANT

Important notes on this procedure

- Before attempting this operation, remove any media.
- To prevent the print heads from drying out, finish this procedure in 10 minutes or less. A warning beep sounds after 10 minutes.
- Never use any implements other than the included cleaning sticks. Cotton swabs or other lint-producing items may damage the print heads.
- Do not use cleaning liquid other than the included cleaning liquid.
- Be sure to use new cleaning sticks. Reusing cleaning sticks will adversely affect the printing results.
- Do not put a cleaning stick that has been used for cleaning into the cleaning liquid. Doing so will deteriorate the cleaning liquid.
- Never rub the print head surface (nozzle surface).
- If you use up the cleaning sticks or cleaning liquid, contact your authorized dealer or visit our website (<https://www.rolanddg.com/>).

When an alarm sounds during cleaning

- A warning beep sounds 10 minutes after operation starts. Stop work, close all the covers, and then tap [Finish All] to end the manual cleaning mode. After that, restart the procedure from the beginning.

Required items	
	
Cleaning sticks	Cleaning liquid

1. Clean the print head caps.

Procedure

1. Remove any media.



2. Tap .

3. Tap [Manual Cleaning].

4. Tap [Execute].

The print heads move to the left end of the machine.

5. Follow the instructions on the operation panel to perform [Manual Cleaning].

- Tap  or  to check the procedure.
- If you complete the work without viewing the instructions, tap [Finish All].

IMPORTANT

- Be sure to use one of the included cleaning sticks.
- Do not use a previously used cleaning stick.
- Do not put a previously used cleaning stick into the cleaning liquid.



IMPORTANT

Use a pair of tweezers to remove the pieces of hardened ink that are 3 mm (0.12 in.) or more in length. Do not use excessive force when pulling on pieces of hardened ink that are difficult to remove. Doing so may damage the print head caps.

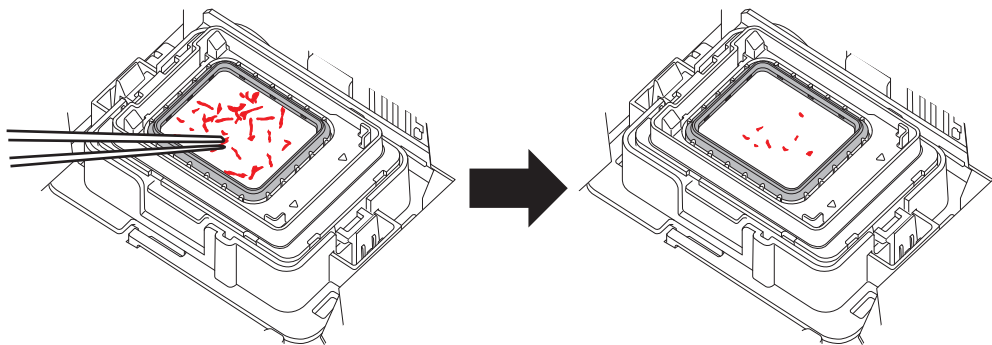

When you have finished cleaning, close the right cover.

2. Clean the print heads.

Procedure

1. Open the left cover.

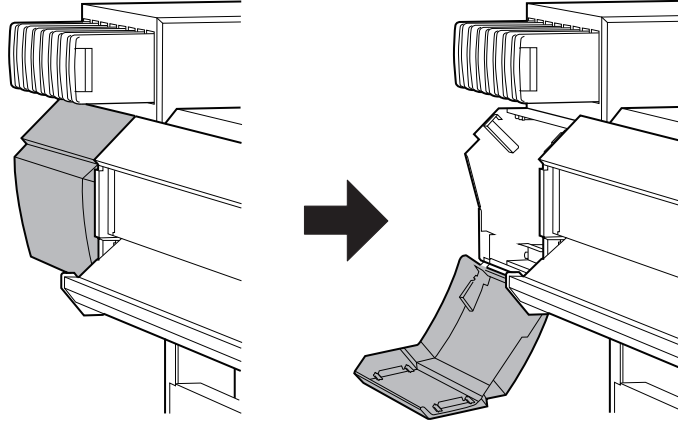

2. Moisten a new cleaning stick with the cleaning liquid.

IMPORTANT

- Be sure to use one of the included cleaning sticks.
- Do not use a previously used cleaning stick.
- Do not put a previously used cleaning stick into the cleaning liquid.



3. Clean the locations shown in the following figure.
Be especially careful to clean away any fibrous dust (lint).

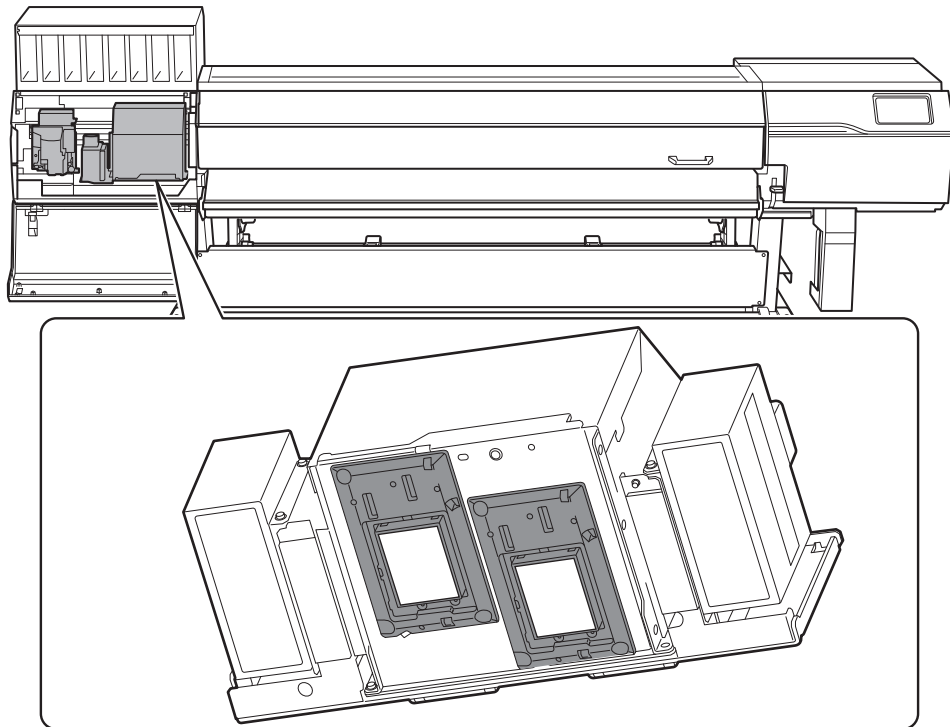

- (1) Press the wide surface of the cleaning stick against the left side and wipe it off. Then, press the opposite surface (which is clean) against the right side and wipe it off.

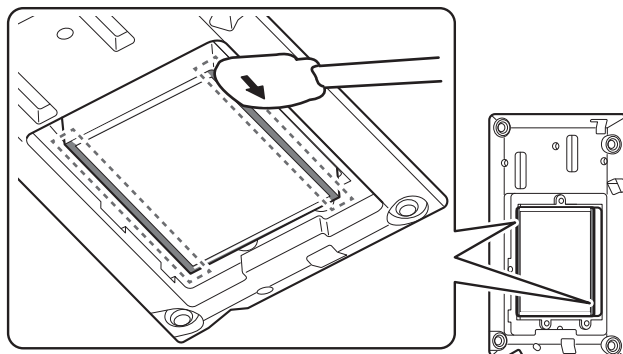

- (2) Stand the cleaning stick upright and wipe off all sides.

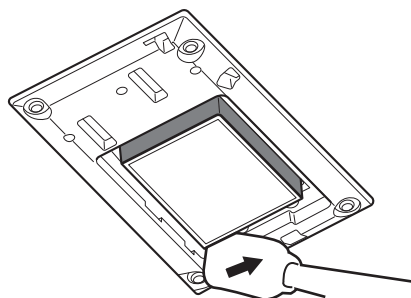

- (3) Use the wide surface of the cleaning stick to wipe away any dirt from the area shown in the figure. If this area has any ink or cleaning liquid that appears likely to drip, use a dry cloth that is not fluffy to gently wipe away the ink or cleaning liquid.

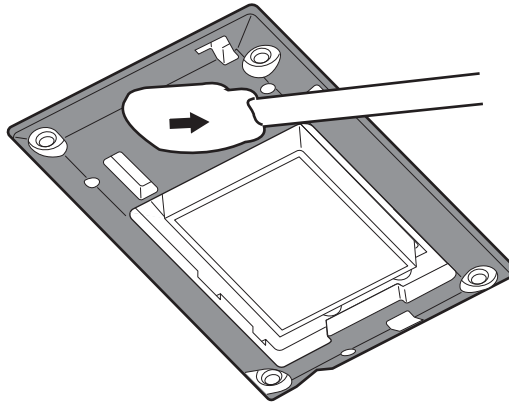

4. Close the left cover.

5. Tap [Finish All].

[Normal cleaning in progress.] is displayed at the top of the screen, and cleaning starts. The (approximate) remaining time for the procedure is displayed on the screen.

6. Tap  to go back to the original screen.

3. Perform a printing test to check the results.

Procedure

1. Set up the media.
P. 31 Setup of New Media
2. Tap  [Nozzle Drop-out Test] on the home screen.
3. Tap [Execute] next to [Printing Test].
Printing of the test pattern starts.

MEMO

Depending on the color of the media used, it may be difficult to check the white ink test pattern.

Tap  [Nozzle Drop-out Test] on the home screen, and then select [Cleaning]>[Printing Test]>[Nozzle Drop-out Test (Base: Black)] to make the base of the white ink black, making it easier to check the white ink. [Nozzle Drop-out Test (Base: Black)] is not displayed if the machine is not equipped with white ink.

4. Check whether there is dot drop-out or dot displacement in the test pattern.
Missing blocks indicate dot drop-out. Collapsed or inclined blocks indicate dot displacement.

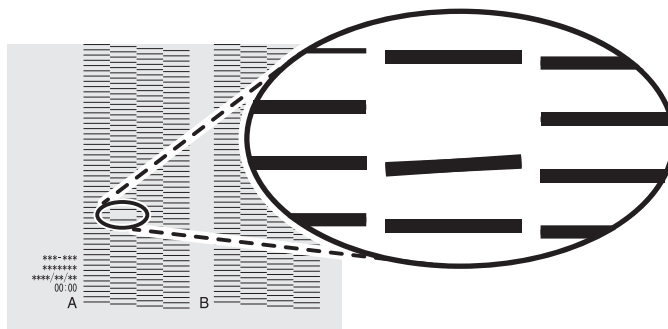

5. If you have opened the front cover, close it.

If no dot drop-out or dot displacement occurs, this operation is finished. Tap  to go back to the original screen.

If dot drop-out or dot displacement is present, perform cleaning such as normal cleaning.

RELATED LINKS

- [P. 265 When Dot Drop-out or Dot Displacement Occurs](#)

Consumable Products and Parts Related to Manual Cleaning

The cleaning sticks, cleaning liquid, and print heads are consumable products or consumable parts.

- If you use up the cleaning sticks and cleaning liquid used for manual cleaning, contact your authorized Roland DG Corporation dealer or visit our website (<https://www.rolanddg.com/>).
- The print heads are components that wear out. Periodic replacement is required, with the frequency of replacement depending on use. Contact your authorized Roland DG Corporation dealer.

Cleaning That Must Be Performed Once a Month or More

When UV-LED Device Cleaning Is Necessary

The UV-LED devices are important components for ink adhesion. They require periodic and appropriate maintenance. It is important to clean the UV-LED devices with the appropriate timing.

Once a month or more

To keep a stable printing condition at all times, perform cleaning once a month or more.

When there is a lot of scattered ink mist and the inside of the machine is soiled

Perform this cleaning every day when frequently printing with the print heads at a distance from the print surface or when ink is emitted to locations that protrude from the print surface. If the scattered ink mist is allowed to harden, it may cause malfunctions.

When the bases and irradiation windows of the UV-LED devices are dirty (see the following figure).

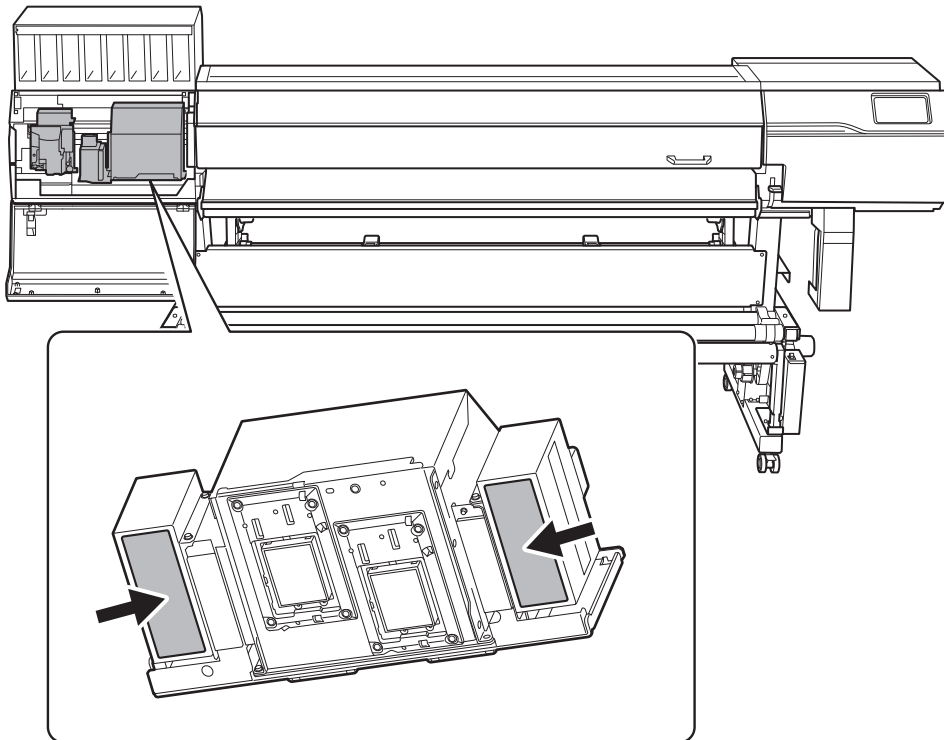

MEMO

- The frequency with which UV-LED device cleaning is required depends on the machine's use. For information about the frequency of cleaning needed for your conditions of use, contact your authorized Roland DG Corporation dealer.
- For hardened ink and other such dirt that cannot be completely cleaned away, contact your authorized Roland DG Corporation dealer.

How to Clean the UV-LED Devices

IMPORTANT

Important notes on this procedure

- Before attempting this operation, remove any media.
- To prevent the print heads from drying out, finish this procedure in 10 minutes or less. A warning beep sounds after 10 minutes.
- The cloths, alcohol, and similar items used in cleaning are not included with the product.

When a warning beep sounds during cleaning

- A warning beep sounds 10 minutes after operation starts. Stop work, close all the covers, and then press [Finish All] to end the manual cleaning mode. After that, restart the procedure from the beginning.

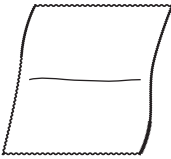
Required items	
	
Anhydrous ethanol or isopropyl alcohol	Cloth (that is not fluffy)

⚠ CAUTION

Do not perform cleaning immediately after printing has finished. (Wait approximately 15 minutes after printing finishes.)

The area around the UV-LED device is hot and may cause burns.

⚠ CAUTION

When using anhydrous ethanol or isopropyl alcohol, be sure to follow the product's usage precautions.

Exercise caution regarding items such as fire, ventilation, and rashes.

⚠ CAUTION

Only use anhydrous ethanol or isopropyl alcohol.

Using chemicals (or similar substances) other than anhydrous ethanol or isopropyl alcohol may lead to UV-LED device damage.

⚠ CAUTION

Use cloth that is not fluffy to wipe off the parts. Do not use a hard material such as metal.

Using cloth that is fluffy or a hard material such as metal may lead to UV-LED device damage.

Procedure

1. Remove any media.

2. Tap .

3. Tap [Manual Cleaning].

4. Tap [Execute].

The print heads move to the left end of the machine.

MEMO

The UV-LED device cleaning uses the manual cleaning menu and moves the print-head carriage to the left side of the machine. Therefore, the manual cleaning procedure appears on the operation panel.

5. Open the left cover.

6. Touch the location shown in the figure to discharge any static electricity.

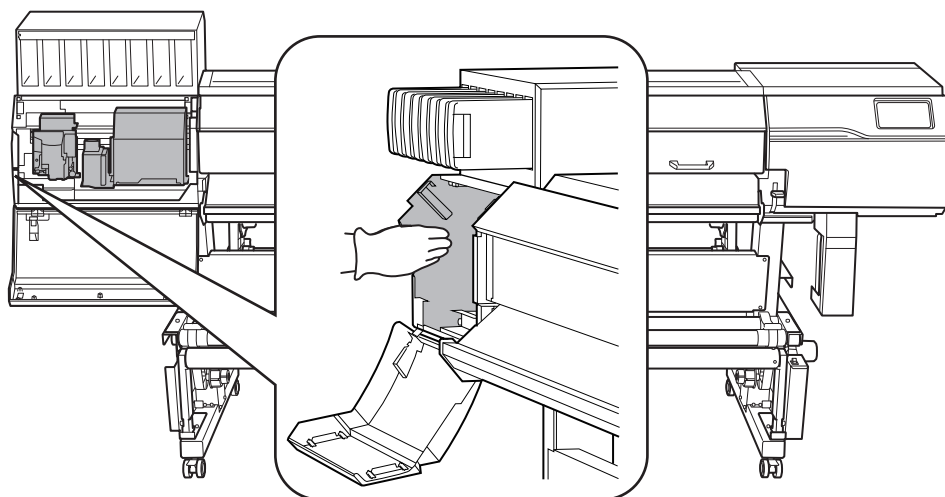

7. Wet a cloth with anhydrous ethanol or isopropyl alcohol, and then wipe off the base and irradiation unit of each UV lamp with this cloth.

Wipe the cloth across each UV lamp for approximately 10 round trips until all the dirt is cleared away.

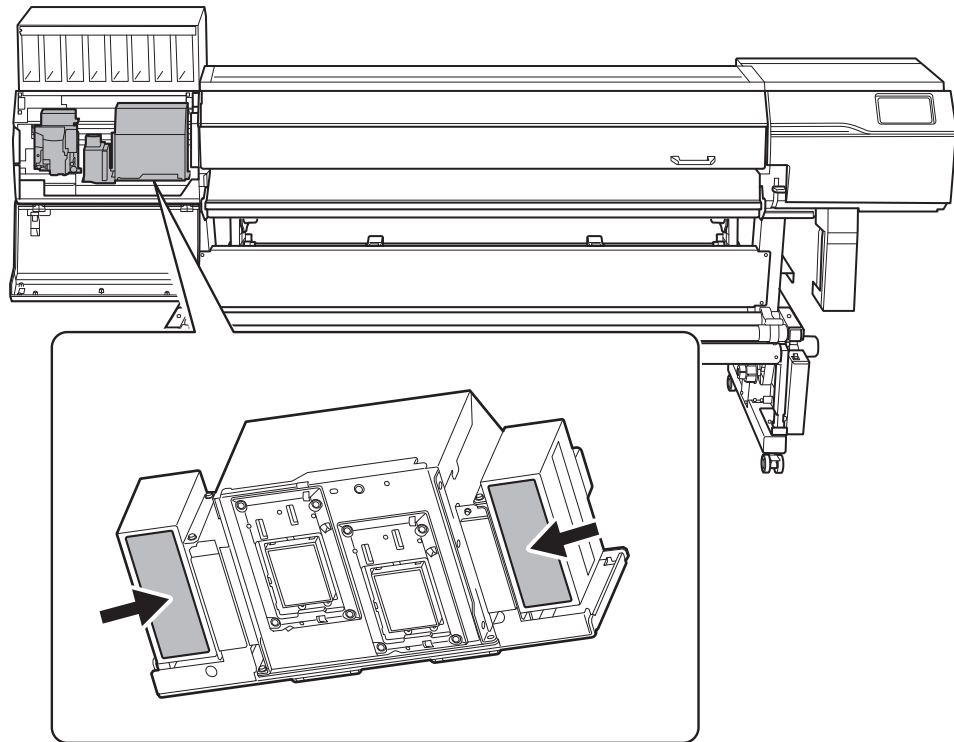

8. Close the left cover.

9. Tap [Finish All].

[Normal cleaning in progress.] is displayed at the top of the screen, and cleaning starts. The (approximate) remaining time for the procedure is displayed on the screen.

10. Tap  to go back to the original screen.

RELATED LINKS

- [P. 256 When UV-LED Device Cleaning Is Necessary](#)

Disposing of Discharged Fluid

Precautions for Disposing of Discharged Fluid	261
If the Discharged Fluid Disposal Message Appears.....	262

Precautions for Disposing of Discharged Fluid

⚠ WARNING

Never place discharged fluid or ink near an open flame.

Doing so may cause a fire.

⚠ CAUTION

To store discharged fluid temporarily, place it in the included drain bottle or in a durable sealed container such as a metal can or polyethylene tank, and cap the container tightly.

Any spillage or vapor leakage may cause fire, odor, or physical distress.

IMPORTANT

Do not store discharged fluid in a location where it is exposed to direct sunlight.

When temporarily storing discharged fluid in the included drain bottle, do not store it in a location that is exposed to direct sunlight. The discharged fluid may harden, making the drain bottle unusable. The drain bottle may also deteriorate, leading to discharged fluid leaks.

IMPORTANT

Dispose of discharged fluid properly, in accordance with the laws in effect in your locale.

Discharged fluid is flammable and contains toxic ingredients. Never attempt to incinerate discharged fluid or discard it with ordinary trash. Also, do not dispose of it in sewer systems, rivers, or streams. Doing so may have an adverse impact on the environment.

If the Discharged Fluid Disposal Message Appears

The [When output, cleaning, and other operations are completed, discard the discharged fluid.] message appears when a certain amount of discharged fluid has collected in the bottle. If this message appears, dispose of the discharged fluid.

Procedure

1. When the message [When output, cleaning, and other operations are completed, discard the discharged fluid.] appears, tap [OK].

2. Tap  to display the notification.

3. Tap the following notification.

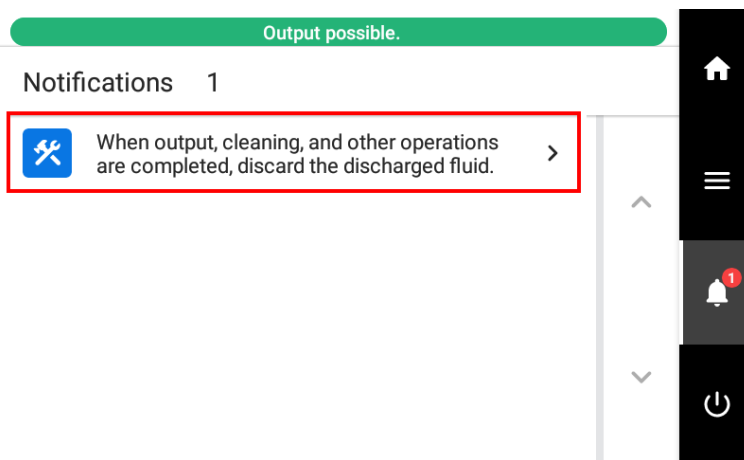

The [Drain Bottle] screen appears.

MEMO

You can dispose of discharged fluid even if the above message has not appeared. Use the following operations to display the drain bottle screen, and then dispose of discharged fluid according to the procedure starting from step 4.

1. Tap .
2. Tap [Maintenance]>[Drain Bottle].

4. Tap [Execute].

5. Remove the drain bottle and discard the discharged fluid.

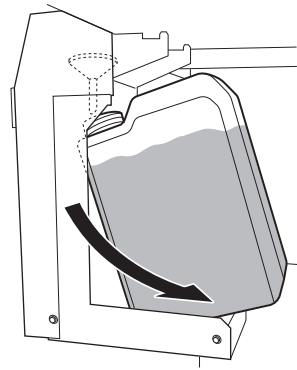

⚠ CAUTION

Before you detach the drain bottle, be sure to wait for the screen to display [Discard the discharged fluid in the bottle.]. After discarding the discharged fluid, promptly attach the drain bottle to the machine.

Failing to follow this procedure may cause discharged fluid to flow out of the tube and spill, soiling your hands or the floor.

IMPORTANT

When you remove the drain bottle, a few drops of discharged fluid may come out of the machine. Exercise caution to prevent this fluid from soiling your hands or the floor.

6. Quickly attach the emptied bottle to the machine once more.
7. Tap [Finish].
The display returns to the original screen.
8. Tap  to go back to the original screen.

Advanced Maintenance

When Dot Drop-out or Dot Displacement Occurs	265
Normal Cleaning Method	265
When Normal Cleaning Is Not Effective	267
Medium Cleaning Method	267
Powerful Cleaning Method	269
When Uneven Color Issues Occur with White Ink	271
Ink Circulating Method	271
Method for Eliminating Uneven Color Issues with Powerful Cleaning	272
Method for Ink Renewal Inside Damper	273
Handling Severe Dot Drop-out, Dot Displacement, and Uneven Colors	276
Ink Renewal Method	276
Partially Restricting the Print Heads Used for Printing	280
Emergency Measure) Cleaning the Print Head Surface	282
When the Operation Panel Is Dirty	285
Operation Panel Cleaning Method	285

When Dot Drop-out or Dot Displacement Occurs

If dot drop-out or dot displacement occurs, perform cleaning of the print heads (normal cleaning).

Normal Cleaning Method

MEMO

If the media has already been set up, the [After cleaning, perform a printing test.] menu option will be displayed on the [Normal Cleaning] screen. When this setting is turned on, a printing test is performed after cleaning.

Procedure

1. Check for the group with dot drop-out or dot displacement by viewing the results of the printing test. The space from "A" to "B" is group A. The space from "B" to the right side is group B.

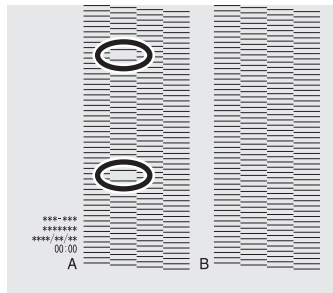

MEMO

If the printing-test results are difficult to interpret

Check the results in a bright location, changing your line of vision. They are visible using the reflection of the light.

2. Tap .

3. Tap [Normal Cleaning].

The screen shown below appears.

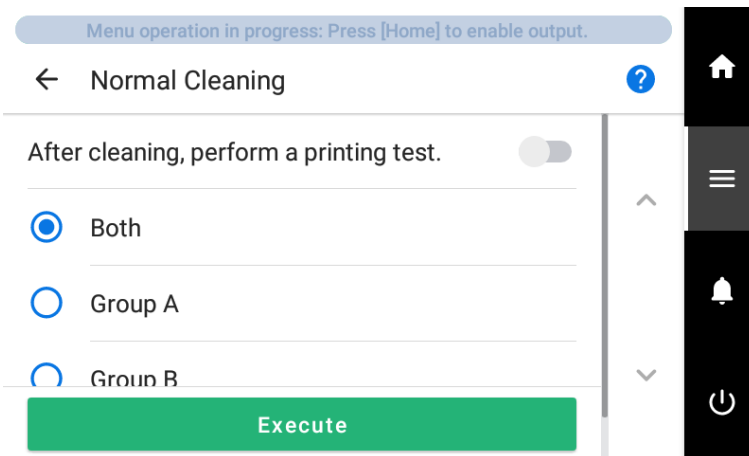

4. Select the group of print heads to clean.

5. Tap [Execute].

Cleaning will start. The status is displayed as [Normal cleaning in progress.] at the top of the operation panel.

On completion, you will return to the original screen.

6. Tap  .

7. Tap [Printing Test].

8. Select [Nozzle Drop-out Test] and tap [Execute].

Perform a printing test again to check whether the dot drop-out and dot displacement have been corrected.

MEMO

Depending on the color of the media used, it may be difficult to check the white ink test pattern.

Tap  [Nozzle Drop-out Test] on the home screen, and then select [Cleaning]>[Printing Test]>[Nozzle Drop-out Test (Base: Black)] to make the base of the white ink black, making it easier to check the white ink. [Nozzle Drop-out Test (Base: Black)] is not displayed if the machine is not equipped with white ink.

MEMO

If the problem persists, try performing [Normal Cleaning] again. If the printer has been used for a long period, dot drop-outs may not be fixed even after performing [Normal Cleaning] two or three times. If this is the case, clean using a different method.

RELATED LINKS

- [P. 132 Performing a Nozzle Drop-out Test](#)
- [P. 267 When Normal Cleaning Is Not Effective](#)

When Normal Cleaning Is Not Effective

Medium Cleaning Method

The print heads are important components that discharge ink. They require periodic and appropriate maintenance. When problems such as dot drop-out are not resolved by [Normal Cleaning], perform the more forceful [Medium Cleaning] to remove clogging from the print heads.

IMPORTANT

[Medium Cleaning] is more forceful cleaning that consumes more ink than [Normal Cleaning].

MEMO

If the media has already been set up, the [After cleaning, perform a printing test.] menu option will be displayed on the [Medium Cleaning] screen. When this setting is turned on, a printing test is performed after cleaning.

Procedure

1. Set up the media.
P. 31 Setup of New Media
2. Tap .
3. Tap [Medium Cleaning].
4. Check for the group with dot drop-out or dot displacement by viewing the results of the printing test.
The space from "A" to "B" is group A. The space from "B" to the right side is group B.

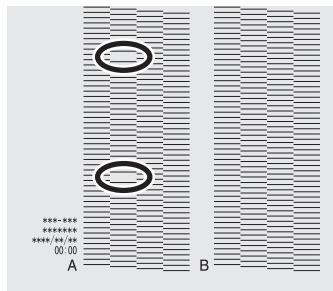

MEMO

If the printing-test results are difficult to interpret

Check the results in a bright location, changing your line of vision. They are visible using the reflection of the light.

5. Select the group of print heads to clean.

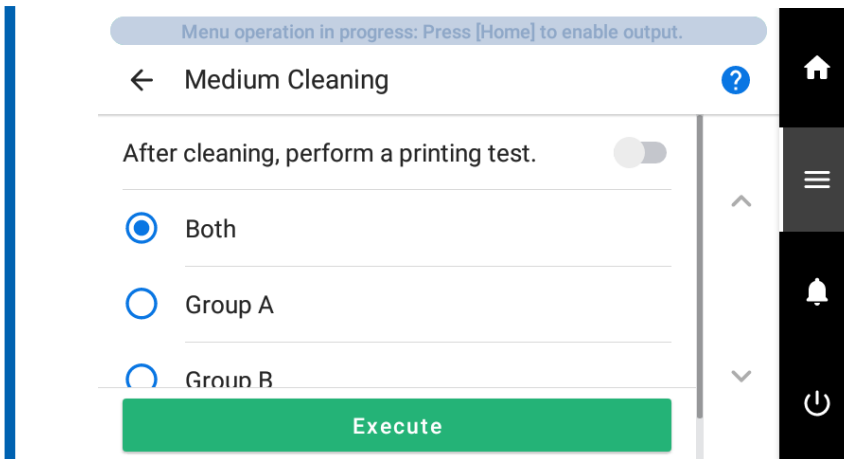

6. Tap [Execute].

Cleaning will start. The status is displayed as [Medium cleaning in progress.] at the top of the operation panel.

On completion, you will return to the original screen.

7. Tap .

8. Tap [Printing Test].

9. Select [Nozzle Drop-out Test] and tap [Execute].

Perform a printing test again to check whether the dot drop-out and dot displacement have been corrected.

MEMO

Depending on the color of the media used, it may be difficult to check the white ink test pattern.

Tap  [Nozzle Drop-out Test] on the home screen, and then select [Cleaning]>[Printing Test]>[Nozzle Drop-out Test (Base: Black)] to make the base of the white ink black, making it easier to check the white ink. [Nozzle Drop-out Test (Base: Black)] is not displayed if the machine is not equipped with white ink.

MEMO

- If the problem persists, try performing [Medium Cleaning] again.
- If problems such as dot drop-out and dot displacement persist even after you have performed [Medium Cleaning] several times, perform [Powerful Cleaning].

RELATED LINKS

- [P. 269 Powerful Cleaning Method](#)

Powerful Cleaning Method

The print heads are important components that discharge ink. They require periodic and appropriate maintenance. When problems such as dot drop-out are not resolved by [Medium Cleaning], perform the more forceful [Powerful Cleaning] to remove clogging from the print heads.

IMPORTANT

[Powerful Cleaning] is more forceful cleaning that consumes more ink than [Medium Cleaning].

MEMO

If the media has already been set up, the [After cleaning, perform a printing test.] menu option will be displayed on the [Powerful Cleaning] screen. When this setting is turned on, a printing test is performed after cleaning.

Procedure

1. Set up the media.
P. 31 Setup of New Media
2. Tap .
3. Tap [Powerful Cleaning].
4. Check for the group with dot drop-out or dot displacement by viewing the results of the printing test.
The space from "A" to "B" is group A. The space from "B" to the right side is group B.

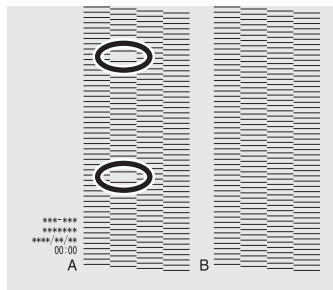

MEMO

If the printing-test results are difficult to interpret

Check the results in a bright location, changing your line of vision. They are visible using the reflection of the light.

5. Tap [Execute].
Cleaning will start. The status is displayed as [Powerful cleaning in progress.] at the top of the operation panel.
On completion, you will return to the original screen.

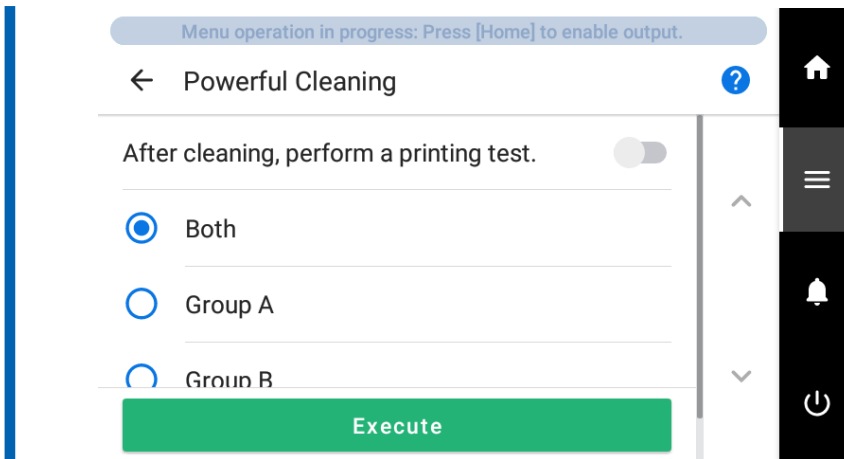

6. Tap .

7. Tap [Printing Test].

8. Select [Nozzle Drop-out Test] and tap [Execute].

Perform a printing test again to check whether the dot drop-out and dot displacement have been corrected.

MEMO

Depending on the color of the media used, it may be difficult to check the white ink test pattern.

Tap  [Nozzle Drop-out Test] on the home screen, and then select [Cleaning]>[Printing Test]>[Nozzle Drop-out Test (Base: Black)] to make the base of the white ink black, making it easier to check the white ink. [Nozzle Drop-out Test (Base: Black)] is not displayed if the machine is not equipped with white ink.

MEMO

- If the problem persists, try performing [Powerful Cleaning] again.
- If problems such as dot drop-out and dot displacement persist even after you have performed [Powerful Cleaning] several times, perform [Manual Cleaning].

RELATED LINKS

- [P. 126 Manual Cleaning Method](#)

When Uneven Color Issues Occur with White Ink

Ink Circulating Method

If uneven color issues with white ink are not resolved even after shaking the ink cartridges to mix the ink, perform [Ink Circulation]. Uneven colors refers to the symptom of printed colors being uneven (such as the color density being inconsistent) even when the same data is printed with the same settings.

MEMO

If the media has already been set up, the [After ink circulation, perform a printing test.] menu appears on the [Ink Circulation] screen. When this setting is turned on, a printing test is performed after ink circulation.

Procedure

1. Tap .

2. Tap [Maintenance]>[Ink Circulation].

3. Tap [Execute].

Depending on the timing with which the [Ink Circulation] is started, cleaning may start. When cleaning is complete, [Ink Circulation] will start.

If uneven output color issues with white ink are not resolved even after performing [Ink Circulation], perform [Powerful Cleaning].

4. Tap  to go back to the original screen.

RELATED LINKS

- [P. 272 Method for Eliminating Uneven Color Issues with Powerful Cleaning](#)

Method for Eliminating Uneven Color Issues with Powerful Cleaning

When uneven color issues with white ink are not resolved even after performing [Ink Circulation], perform the more forceful [Powerful Cleaning] to eliminate these issues. Uneven colors refers to the symptom of printed colors being uneven (such as the color density being inconsistent) even when the same data is printed with the same settings.

IMPORTANT

The ink in the print heads is discharged to stabilize the output color, so a certain amount of ink is consumed.

MEMO

If the media has already been set up, the [After cleaning, perform a printing test.] menu option will be displayed on the [Powerful Cleaning] screen. When this setting is turned on, a printing test is performed after cleaning.

Procedure

1. Tap .

2. Tap [Powerful Cleaning].

3. Select [Both].

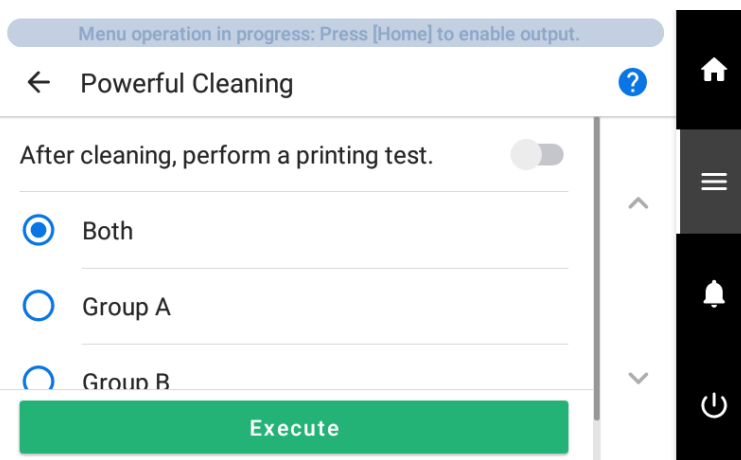

4. Tap [Execute].

Cleaning will start. The status is displayed as [Powerful cleaning in progress.] at the top of the operation panel.

On completion, you will return to the original screen.

If uneven output color issues with white ink are not resolved even after performing [Powerful Cleaning], perform [Ink Renewal Inside Damper].

RELATED LINKS

- [P. 273 Method for Ink Renewal Inside Damper](#)

Method for Ink Renewal Inside Damper

If uneven color issues with white ink are not resolved even after performing [Powerful Cleaning], perform [Ink Renewal Inside Damper]. Uneven colors refers to the symptom of printed colors being uneven (such as the color density being inconsistent) even when the same data is printed with the same settings.

[Ink Renewal Inside Damper] can be used to stabilize the output colors by replacing the ink.

IMPORTANT

- [Ink Renewal Inside Damper] discharges the ink in the damper, so it consumes more ink than [Powerful Cleaning].
- When you perform [Ink Renewal Inside Damper], replace all the ink pouches other than those in the C, M, Y, and K ink cartridges with new ink pouches. If the ink runs out during cleaning, a [Cleaning Error (Ink Cartridge)] will occur and cleaning will stop.

The ink pouches that you have removed can still be used in operations other than ink renewal inside the damper (such as printing).

Procedure

1. Tap .

2. Tap [Maintenance]>[Ink Renewal Inside Damper].

3. Replace all the ink pouches other than those in the C, M, Y, and K ink cartridges with new ink pouches.

[P. 114 Ink Replacement Method](#)

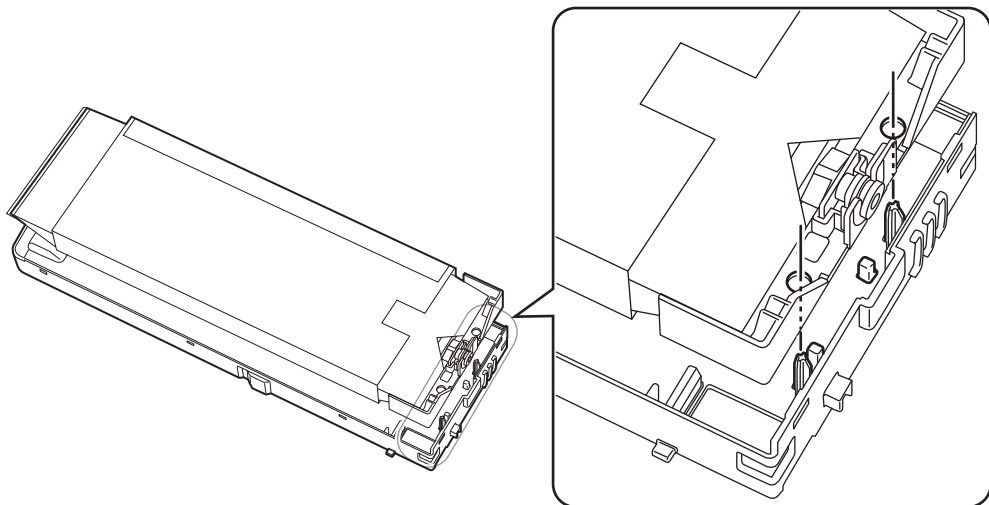

4. Tap [Execute].

Cleaning will start. On completion, you will return to the original screen.

MEMO

If [Discard the discharged fluid in the bottle.] appears after tapping [Execute]

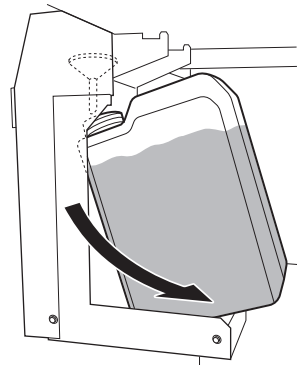

1. Remove the drain bottle and discard the discharged fluid.

IMPORTANT

When you remove the drain bottle, a few drops of discharged fluid may come out of the machine. Exercise caution to prevent this fluid from soiling your hands or the floor.

2. Quickly attach the emptied drain bottle to the machine once more.
3. Tap [Finish].

⚠ CAUTION

Before you detach the drain bottle, be sure to wait for the screen to display [Discard the discharged fluid in the bottle.]. After discarding the discharged fluid, promptly attach the drain bottle to the machine.

Failing to follow this procedure may cause discharged fluid to flow out of the tube and spill, soiling your hands or the floor.

⚠ WARNING

Never place discharged fluid or ink near an open flame. Doing so may cause a fire.

⚠ CAUTION

To store discharged fluid temporarily, place it in the included drain bottle or in a durable sealed container such as a metal can or polyethylene tank, and cap the container tightly. Any spillage or vapor leakage may cause fire, odor, or physical distress.

IMPORTANT

Do not store discharged fluid in a location where it is exposed to direct sunlight.

When temporarily storing discharged fluid in the included drain bottle, do not store it in a location that is exposed to direct sunlight. The discharged fluid may harden, making the drain bottle unusable. The drain bottle may also deteriorate, leading to discharged fluid leaks.

IMPORTANT

Dispose of discharged fluid properly, in accordance with the laws in effect in your locale.

Discharged fluid is flammable and contains toxic ingredients. Never attempt to incinerate discharged fluid or discard it with ordinary trash. Also, do not dispose of it in sewer systems, rivers, or streams. Doing so may have an adverse impact on the environment.

5. If uneven output color issues with white ink are not resolved even after performing [Ink Renewal Inside Damper], perform [Ink Renewal].

6. Tap  to go back to the original screen.

RELATED LINKS

- [P. 276 Ink Renewal Method](#)
- [P. 345 \[Cleaning Error \(Ink Cartridge\)\]](#)

Handling Severe Dot Drop-out, Dot Displacement, and Uneven Colors

Ink Renewal Method

Perform [Ink Renewal] in the following situations.

- When ink discharge issues such as dot drop-out are not corrected after performing cleaning using the cleaning function (normal, medium, powerful) and [Manual Cleaning]
- When white is uneven even after performing [Ink Renewal Inside Damper]
- When a color other than white is uneven even after shaking the ink cartridges to mix the ink

IMPORTANT

A large amount of ink will be discharged during [Ink Renewal]. Perform this operation only when ink discharge issues such as dot drop-out, dot displacement, and uneven colors cannot be corrected even after performing cleaning using the other cleaning functions (normal, medium, powerful, manual, and ink renewal inside damper).

RELATED LINKS

- [P. 265 When Dot Drop-out or Dot Displacement Occurs](#)
- [P. 267 Medium Cleaning Method](#)
- [P. 269 Powerful Cleaning Method](#)
- [P. 126 Manual Cleaning Method](#)
- [P. 272 Method for Eliminating Uneven Color Issues with Powerful Cleaning](#)
- [P. 273 Method for Ink Renewal Inside Damper](#)

1. Start the [Ink Renewal] menu.

Procedure

1. Tap .
2. Tap [Maintenance]>[Ink Renewal].
3. Check for the group with dot drop-out, dot displacement, or uneven colors by viewing the results of the printing test.
The space from "A" to "B" is group A. The space from "B" to the right side is group B.

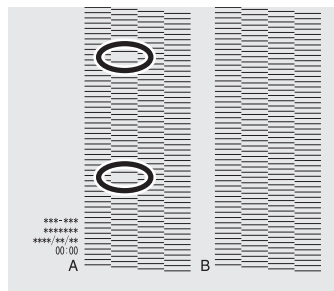

MEMO

If the printing-test results are difficult to interpret

Check the results in a bright location, changing your line of vision. They are visible using the reflection of the light.

4. Select the group of print heads to renew the ink of.

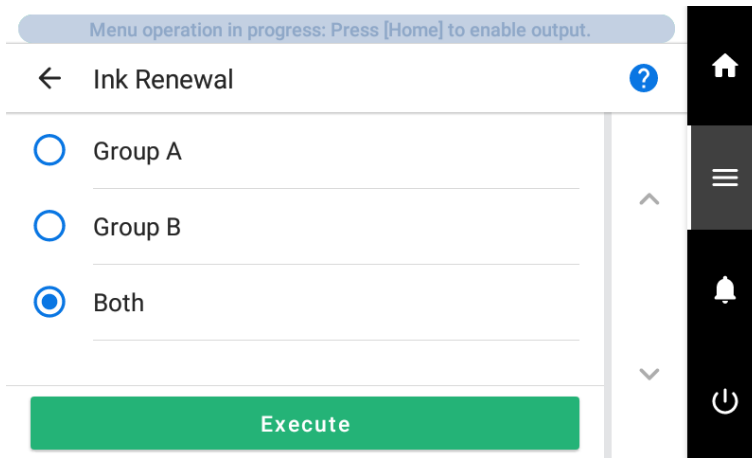

5. Tap [Execute].

The [Discard the discharged fluid in the bottle.] screen appears.

6. Remove the drain bottle and discard the discharged fluid.

IMPORTANT

When you remove the drain bottle, a few drops of discharged fluid may come out of the machine. Exercise caution to prevent this fluid from soiling your hands or the floor.

CAUTION

Before you detach the drain bottle, be sure to wait for the screen to display [Discard the discharged fluid in the bottle.]. After discarding the discharged fluid, promptly attach the drain bottle to the machine.

Failing to follow this procedure may cause discharged fluid to flow out of the tube and spill, soiling your hands or the floor.

WARNING

Never place discharged fluid or ink near an open flame.

Doing so may cause a fire.

CAUTION

To store discharged fluid temporarily, place it in the included drain bottle or in a durable sealed container such as a metal can or polyethylene tank, and cap the container tightly.

Any spillage or vapor leakage may cause fire, odor, or physical distress.

IMPORTANT

Do not store discharged fluid in a location where it is exposed to direct sunlight.

When temporarily storing discharged fluid in the included drain bottle, do not store it in a location that is exposed to direct sunlight. The discharged fluid may harden, making the drain bottle unusable. The drain bottle may also deteriorate, leading to discharged fluid leaks.

IMPORTANT

Dispose of discharged fluid properly, in accordance with the laws in effect in your locale.

Discharged fluid is flammable and contains toxic ingredients. Never attempt to incinerate discharged fluid or discard it with ordinary trash. Also, do not dispose of it in sewer systems, rivers, or streams. Doing so may have an adverse impact on the environment.

7. Quickly attach the emptied drain bottle to the machine once more.

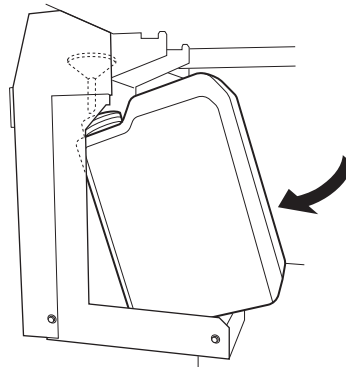

8. Tap [Finish].
Ink renewal starts. On completion, you will return to the original screen.
9. Tap  to go back to the original screen.

2. Perform a printing test to check the results.

Procedure

1. Set up the media.
P. 31 Setup of New Media
2. Tap  [Nozzle Drop-out Test] on the home screen.
3. Tap [Execute] next to [Printing Test].
Printing of the test pattern starts.

MEMO

Depending on the color of the media used, it may be difficult to check the white ink test pattern.

Tap  [Nozzle Drop-out Test] on the home screen, and then select [Cleaning]>[Printing Test]>[Nozzle Drop-out Test (Base: Black)] to make the base of the white ink black, making it easier to check the white ink. [Nozzle Drop-out Test (Base: Black)] is not displayed if the machine is not equipped with white ink.

4. Check whether there is dot drop-out or dot displacement in the test pattern and whether its uneven colors have been eliminated.

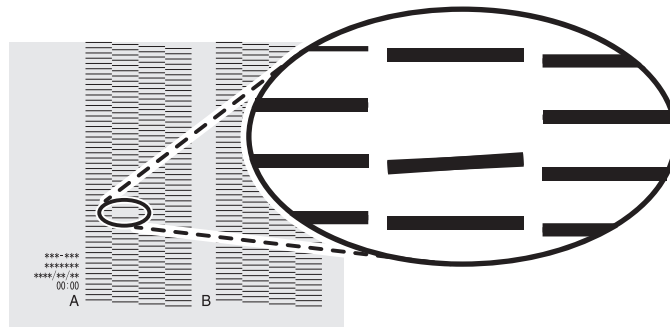

5. If you have opened the front cover, close it.
If no dot drop-out or dot displacement occurs and if there are no uneven colors, this operation is finished. Tap  to go back to the original screen.

If the dot drop-out or dot displacement location is different, perform medium cleaning another two or three times.

If this problem is not fixed, contact your authorized dealer.

Partially Restricting the Print Heads Used for Printing

When dot drop-out or dot displacement is not improved even after renewing the ink, partially restrict the print heads to use for printing. This operation is called the "nozzle mask," and while it slows down printing speed, it also allows you to decrease the impact of dot drop-out or dot displacement.

First print a test pattern, and then select the nozzle group to use by viewing the test results. After that, use VersaWorks to select the nozzle group used for printing.

1. Perform a printing test for the nozzle mask.

Procedure

1. Set up the media.

[P. 31 Setup of New Media](#)

2. Tap .

3. Tap [Cleaning]>[Printing Test].

4. Select [Nozzle Mask Test] and tap [Execute].

Printing of the test pattern starts.

5. Check for the nozzle group with dot drop-out or dot displacement by viewing the results of the printing test.

The results of the printing test are displayed separately for nozzle groups "1" and "2." The following shows a dot drop-out in nozzle group 1.

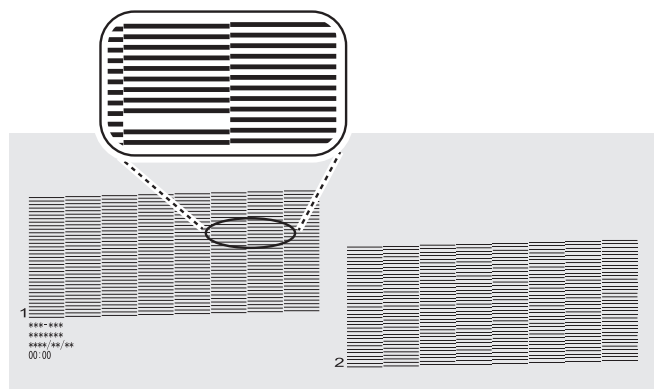

MEMO

If the printing-test results are difficult to interpret

Check the results in a bright location, changing your line of vision. They are visible using the reflection of the light.

6. If you have opened the front cover, close it.

If no dot drop-out or dot displacement occurs, this operation is finished. Tap  to go back to the original screen.

2. Limit the print heads used for printing.

Procedure

1. Start VersaWorks.
2. Click [Printer]>[Printer Settings].
The [Printer Settings] dialog box appears.
3. From the [Printer List], select the printer whose print heads will be limited.
4. Click [Advanced].
The [Advanced] dialog box appears.
5. Select the nozzle group to use in printing from the printing-test results.
The nozzle group numbers that can be selected vary depending on the model being used and the firmware version. Select the appropriate group number (or all the group numbers) to match the results of the printing test.

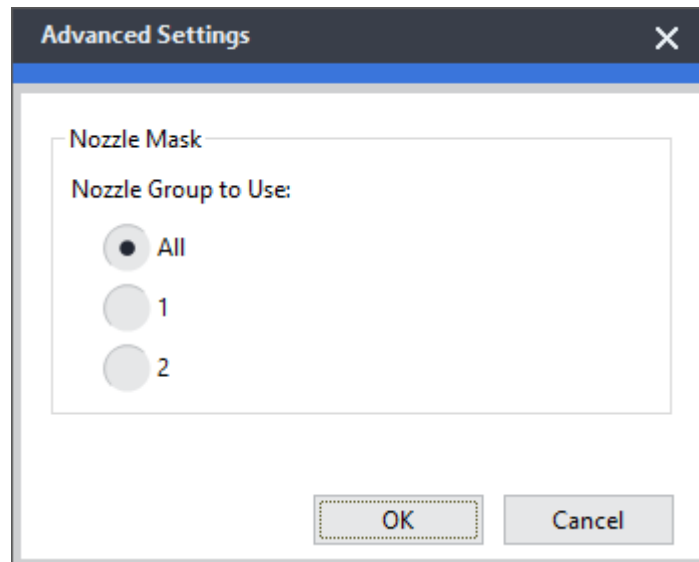

6. Click [OK].
Close the [Advanced] dialog box.
7. Click [OK].
Close the [Printer Settings] dialog box.
The  icon is displayed on top of the image of the printer whose setting has been changed.

RELATED LINKS

- VersaWorks manual (<https://downloadcenter.rolanddg.com/VersaWorks6>)

Emergency Measure) Cleaning the Print Head Surface

When dot drop-out or dot deflection is not improved even if cleaning is performed several times, you can clean the surface of the print heads as an emergency measure. The print head surface (nozzle surface) is a very delicate mechanism, so work must be performed carefully and cautiously.

This operation is an emergency measure. It may damage defect-free parts depending on the symptoms, worsening the symptoms. If you have any questions, contact your authorized dealer.

⚠ CAUTION

Do not perform cleaning immediately after printing has finished. (Wait approximately 15 minutes after printing finishes.)

The area around the UV-LED device is hot and may cause burns.

⚠ WARNING

Be sure to perform operations as specified by the instructions, and never touch any area not specified in the instructions.

Sudden movement of the machine may cause injury.



IMPORTANT

Important notes on this procedure

- Before attempting this operation, remove any media.
- To prevent the print heads from drying out, finish this procedure in 10 minutes or less. A warning beep sounds after 10 minutes.
- Never use any implements other than the included cleaning sticks. Cotton swabs or other lint-producing items may damage the print heads.
- Do not use cleaning liquid other than the included cleaning liquid.
- Be sure to use new cleaning sticks. Reusing cleaning sticks will adversely affect the printing results.
- Do not put a cleaning stick that has been used for cleaning into the cleaning liquid. Doing so will deteriorate the cleaning liquid.
- Never rub the print head surface (nozzle surface).
- If you use up the cleaning sticks or cleaning liquid, contact your authorized dealer or visit our website (<https://www.rolanddg.com/>).

When an alarm sounds during cleaning

- A warning beep sounds 10 minutes after operation starts. Stop work, close all the covers, and then tap [Finish All] to end the manual cleaning mode. After that, restart the procedure from the beginning.

Required items	
	
Cleaning sticks	Cleaning liquid

Procedure

1. Remove any media.

2. Tap .

3. Tap [Manual Cleaning].

4. Tap [Execute].

The print heads move to the left end of the machine.

IMPORTANT

The cleaning of the print head surface (as an emergency measure) uses the manual cleaning menu and moves the print-head carriage to the left side of the machine. Therefore, the manual cleaning procedure appears on the operation panel.

5. Open the right cover.

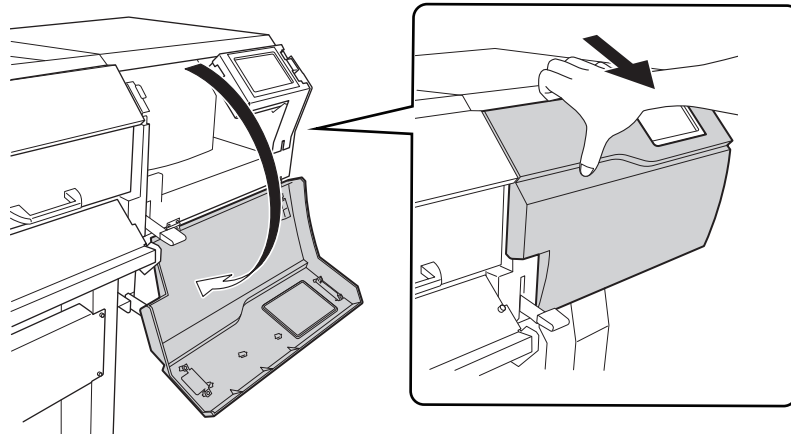

6. Touch the location shown in the figure to discharge any static electricity.

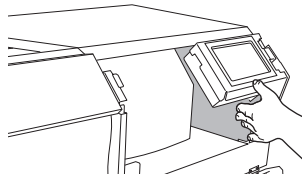

7. Apply a large amount of cleaning liquid to a new cleaning stick.

IMPORTANT

- Be sure to use one of the included cleaning sticks.
- Do not use a previously used cleaning stick.
- Do not put a previously used cleaning stick into the cleaning liquid.



8. Very gently touch the cleaning stick against the print head surface (nozzle surface).

Very softly press the cleaning stick against the print head so that cleaning liquid soaks into the print head surface (nozzle surface). Never rub the stick on the surface or press it forcibly.

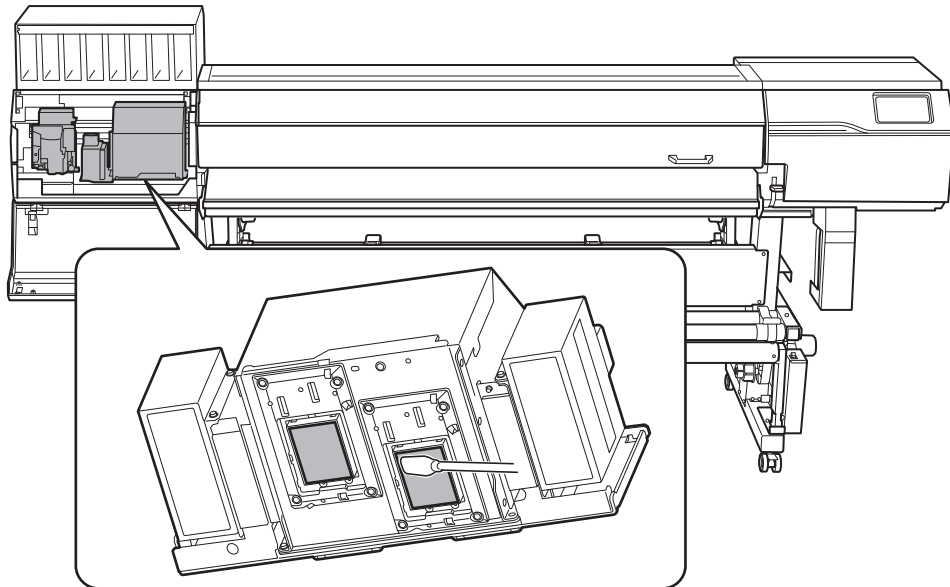

When the Operation Panel Is Dirty

Operation Panel Cleaning Method

IMPORTANT

Important notes on this procedure

- The cloths, alcohol, and similar items used in cleaning are not included with the product.
- Be sure to use a cloth when cleaning the operation panel. Liquid entering into the operation panel through its gaps may cause printer malfunctions.

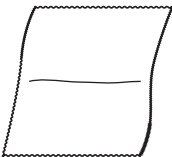
Required items	
	
Anhydrous ethanol or isopropyl alcohol	Cloth (that is not fluffy)

⚠ CAUTION

When using anhydrous ethanol or isopropyl alcohol, be sure to follow the product's usage precautions.

Exercise caution regarding items such as fire, ventilation, and rashes.

⚠ CAUTION

Only use anhydrous ethanol or isopropyl alcohol.

Using chemicals (or similar substances) other than anhydrous ethanol or isopropyl alcohol may lead to operation panel damage.

Procedure

1. Switch off the sub power.
2. Wipe off the operation panel with a cloth soaked in anhydrous ethanol or isopropyl alcohol.
Wipe slowly and gently to remove the grime.

Replacing Consumable Parts

Replacing Parts for Maintenance	287
Replacing the Wiper	287
Replacing the Print Head Caps	290
Replacing the wiper cleaner.....	292
Replacing the UV Mist Filters.....	294
Replacing the Flushing Sponge	296
Replacing the Blade/Separating Knife.....	298
Replacing the Blade.....	298
Replacing the Separating Knife	304
Consumable Parts That Require Inquiries before Replacement	306

Replacing Parts for Maintenance

Replacing the Wiper

The wiper periodically cleans the surface of the print heads.

When it is time to replace the wiper, the message [The time for wiper replacement has arrived.] appears. In this situation, replace the wiper.

For information about purchasing wipers, contact your authorized dealer or visit our website (<https://www.rolanddg.com/>).

⚠ WARNING

Be sure to perform operations as specified by the instructions, and never touch any area not specified in the instructions.

Sudden movement of the machine may cause injury.

Required item

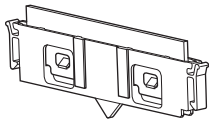

Wiper

IMPORTANT



Take care to prevent ink from adhering to the operation panel.

Procedure

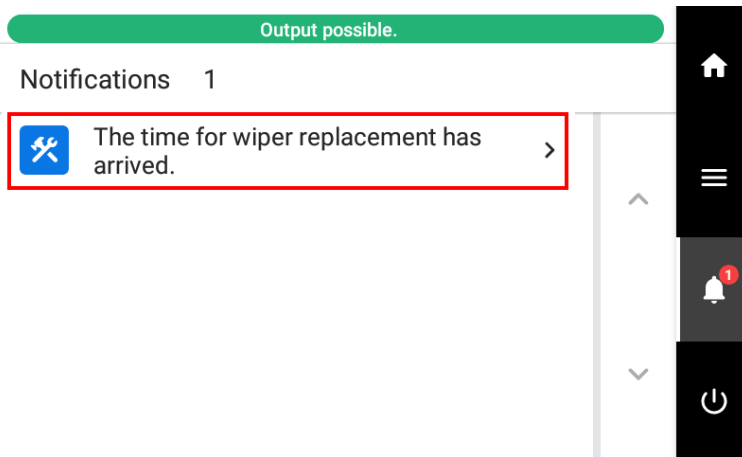
1. When the message [The time for wiper replacement has arrived.] appears, tap [OK].
2. Remove any media.
3. Tap  to display the messages.
4. Tap [The time for wiper replacement has arrived.].



The [Wiper Replacement] screen appears.

5. Tap [Execute].
The print-head carriage moves to a location where wiper replacement is possible.
6. Follow the instructions on the operation panel to replace the wiper.
 - Tap  or  to check the procedure.
 - If you complete the work without viewing the instructions, tap [Finish All].

IMPORTANT

After installing the wiper, hold the hooks on the left and right sides, pressing in just enough so that the locks are not released. Then, gently pull the wiper up and check that it is not removed.

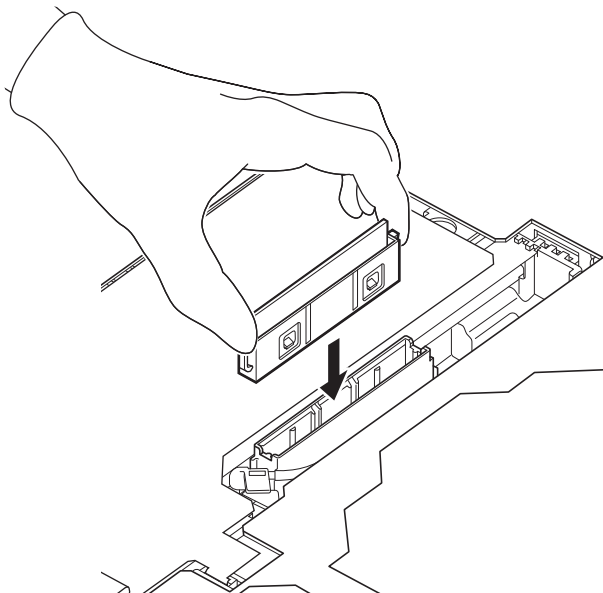

7. When the wiper replacement is finished, tap [Finish All].
8. When [Close the cover.] appears, close the right cover.
When you close the right cover, you are returned to the original screen.

9. Tap  to go back to the original screen.

Replacing the Print Head Caps

The print head caps seal the nozzle surfaces of the print heads, preventing these surfaces from drying out and preventing dust from adhering to them.



When it is time to replace the print head caps, the message [The time for cap replacement has arrived.] appears. In this situation, replace the print head caps.

For information about purchasing print head caps, contact your authorized dealer or visit our website (<https://www.rolanddg.com/>).

⚠ WARNING

Be sure to perform operations as specified by the instructions, and never touch any area not specified in the instructions.

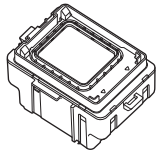
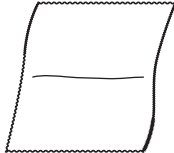
Sudden movement of the machine may cause injury.

Required items		
		
Print head cap	Cloth (that is not fluffy)	Cleaning sticks

Procedure

1. When the message [The time for cap replacement has arrived.] appears, tap [OK].

2. Remove any media.

3. Tap  to display the messages.

4. Tap [The time for cap replacement has arrived.].

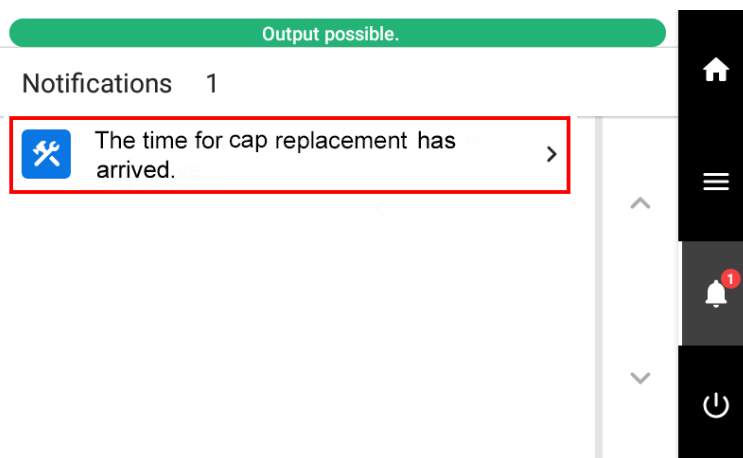



The [Cap Replacement] screen appears.

5. Tap [Execute].

The print-head carriage moves to a location where print head cap replacement is possible.

6. Follow the instructions on the operation panel to replace the print head caps.

- Tap  or  to check the procedure.
- If you complete the work without viewing the instructions, tap [Finish All].

IMPORTANT

Ink may drip from the removed print head cap. Exercise caution to prevent this fluid from soiling your hands or the floor.

To prevent ink from adhering to your hands, the machine, or the floor, cover the bottom surface of the removed print head cap with paper towels or something similar.

7. When the print head cap replacement is finished, tap [Finish All].

8. When [Close the cover.] appears, close the right cover.

When you close the right cover, you are returned to the original screen.

9. Tap  to go back to the original screen.

Replacing the wiper cleaner

The wiper cleaner removes ink, dust, and similar substances that have adhered to the wiper during cleaning.



When it is time to replace the wiper cleaner, the message [The time for wiper cleaner replacement has arrived.] appears. In this situation, replace the wiper cleaner.

For information about purchasing wiper cleaners, contact your authorized dealer or visit our website (<https://www.rolanddg.com/>).

⚠ WARNING

Be sure to perform operations as specified by the instructions, and never touch any area not specified in the instructions.

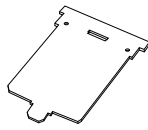
Sudden movement of the machine may cause injury.

Required items	
	
Wiper cleaner	Tweezers

IMPORTANT

Take care to prevent ink from adhering to the operation panel.

Procedure

1. When the message [The time for wiper cleaner replacement has arrived.] appears, tap [OK].
2. Remove any media.
3. Tap  to display the messages.
4. Tap [The time for wiper cleaner replacement has arrived.].

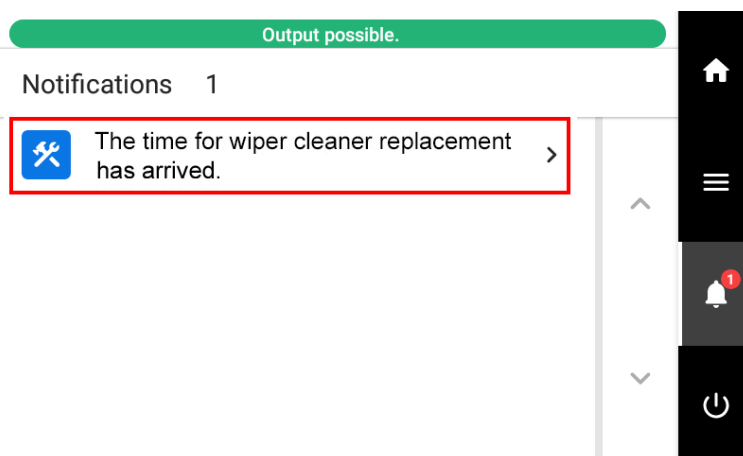



The [Wiper Cleaner Replacement] screen appears.

5. Tap [Execute].

The print-head carriage moves to a location where wiper cleaner replacement is possible.

6. Follow the instructions on the operation panel to replace the wiper cleaner.

- When the message [Eliminate static electricity.] appears, touch the indicated location, and then tap [Finish All] to display the instructions for wiper cleaner replacement.
- Tap  or  to check the procedure.
- If you complete the work without viewing the instructions, tap [Finish All].

7. When the wiper cleaner replacement is finished, tap [Finish All].

8. When [Close the cover.] appears, close the right cover and the flushing cover.

When you close the right cover and the flushing cover, you are returned to the original screen.

9. Tap  to go back to the original screen.

Replacing the UV Mist Filters

The UV mist filters absorb the ink mist generated during printing to reduce the amount of ink mist that adheres to the UV lamp.

When it is time to replace the UV mist filters, the message [The time for UV mist filter replacement has arrived.] appears. If this message appears, replace the UV mist filters.

For information about purchasing UV mist filters, contact your authorized dealer or visit our website (<https://www.rolanddg.com/>).

⚠ WARNING

Be sure to perform operations as specified by the instructions, and never touch any area not specified in the instructions.

Sudden movement of the machine may cause injury.

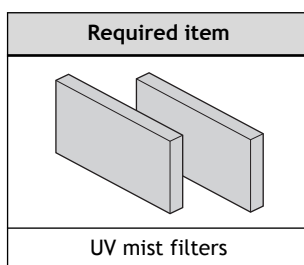

Procedure

1. When the message [The time for UV mist filter replacement has arrived.] appears, tap [OK].
2. Remove any media.
3. Tap  to display the messages.
4. Tap [The time for UV mist filter replacement has arrived.].

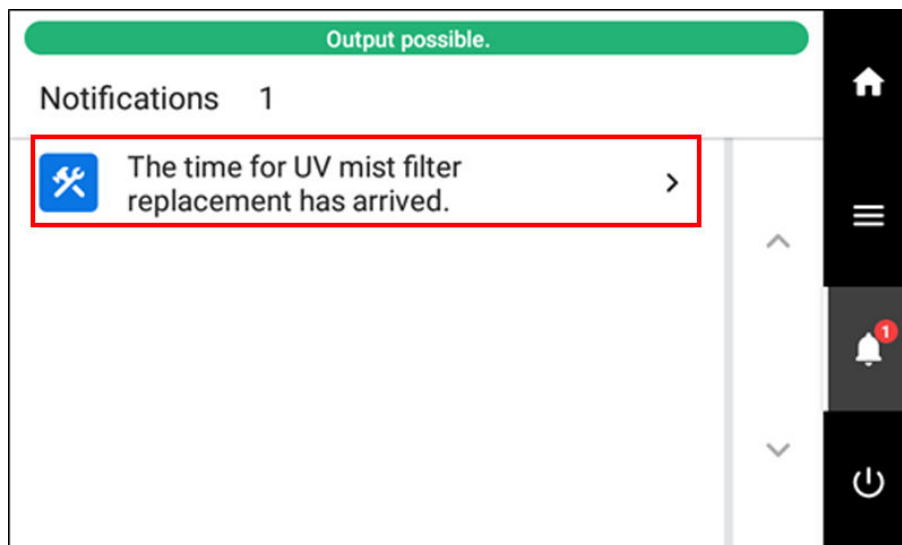



The [UV Mist Filter Replacement] screen appears.

5. Tap [Execute].

The print-head carriage moves to a location where the right UV mist filter can be replaced.

6. Follow the instructions on the operation panel to replace the UV mist filters.

- Tap  or  to check the procedure.
- There is one UV-LED device on the left side of the print heads and one on the right side. The instructions are displayed for the left and right sides.
- If you complete the work to replace the left UV mist filter without viewing the instructions, tap **[Finish All]**. When you do so, the instructions for the right side appear. If you complete the work to replace the right UV mist filter without viewing the instructions, tap **[Finish All]**.

MEMO

Because UV mist filters do not have a specified front or back, they can be attached with either orientation.

7. When the UV mist filter replacement is finished, tap [Finish All].**8. When [Close the cover.] appears, close the front cover.**

When you close the front cover, you are returned to the original screen.

9. Tap  to go back to the original screen.

Replacing the Flushing Sponge

The flushing sponge absorbs the discharged ink to prevent clogging of the print heads.

When it is time to replace the flushing sponge, the message [The time for flushing sponge replacement has arrived.] appears. In this situation, replace the flushing sponge.

For information about purchasing flushing sponges, contact your authorized dealer or visit our website (<https://www.rolanddg.com/>).

⚠ WARNING

Be sure to perform operations as specified by the instructions, and never touch any area not specified in the instructions.

Sudden movement of the machine may cause injury.

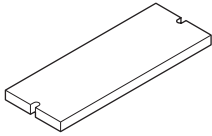
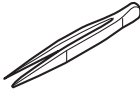
Required items	
	
Flushing sponge	Tweezers

Procedure

1. When the message [The time for flushing sponge replacement has arrived.] appears, tap [OK].
2. Remove any media.
3. Tap  to display the messages.
4. Tap [The time for flushing sponge replacement has arrived.].

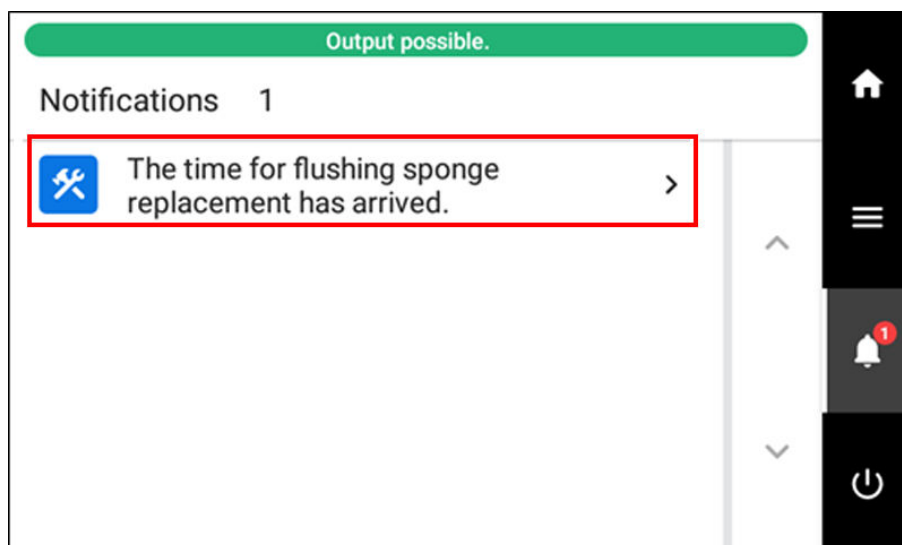



The [Flushing Sponge Replacement] screen appears.

5. Tap [Execute].

The print-head carriage moves to a location where flushing sponge replacement is possible.

6. Follow the instructions on the operation panel to replace the flushing sponge.

- Tap  or  to check the procedure.
- If you complete the work without viewing the instructions, tap [Finish All].

MEMO

Because flushing sponges do not have a specified front or back, they can be attached with either orientation.

7. When the flushing sponge replacement is finished, tap [Finish All].

8. When [Close the cover.] appears, close the right cover and the flushing cover.

When you close the right cover and the flushing cover, you are returned to the original screen.

9. Tap  to go back to the original screen.

Replacing the Blade/Separating Knife

Replacing the Blade

If the blade becomes dull, if the edge of the blade is chipped, or if the cutting quality is lowered, replace the blade with a new blade.

⚠ WARNING

Be sure to perform operations as specified by the instructions, and never touch any area not specified in the instructions.

Sudden movement of the machine may cause injury.

⚠ CAUTION



Never touch the tip of the knife.

Doing so may result in injury. The cutting performance of the blade will also be impaired.

Required item

Replacement blade

1. Replace the blade.

Procedure

1. Remove any media.
2. Tap .
3. Tap [Maintenance]>[Blade Replacement].
The [Blade Replacement] screen appears.
4. Tap [Execute].
The cutting carriage moves to a position where blade replacement is possible.
5. Follow the instructions on the operation panel to replace the blade.
 - Tap  or  to check the procedure.
 - If you complete the work without viewing the instructions, tap [Finish All].

MEMO

When attaching the blade, orient its tip correctly.

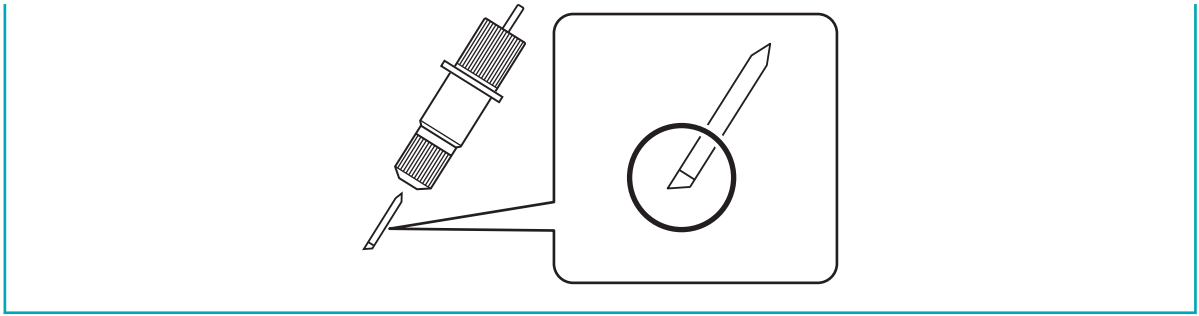

6. When the blade replacement is finished, tap [Finish All].
7. When [Close the cover.] appears, close the front cover.
When you close the front cover, you are returned to the original screen.
8. Tap  to go back to the original screen.





2. Make adjustments according to the new blade.

Procedure

1. Set up the media.

2. Tap .

3. Tap [Change] next to [Output Start Location].



4. Tap , , , or  to move the cutting carriage to the location where you want to carry out the cutting test.
You can freely set the location for the cutting test.

5. Tap [Set Base Point Here].
You are returned to the [Blade Adjustment] screen.

6. Tap [Execute] next to [Cutting Test].
The test pattern is cut.

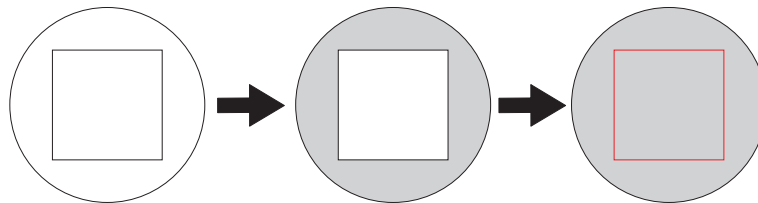
7. Check the results of the cutting test.



Check item	Result	Setting item	Adjustment
Check the shape.	The cut shape is distorted.	[Cutting Speed]	Reduce
Peel off the circle.	The square also peels off.	[Blade Force]	Increase
	Some uncut areas remain.	[Cutting Speed]	Reduce
Peel off the square.	The blade leaves faint traces on the backing paper.	[Blade Force]	No change
	The blade trace is indistinct.		Increase
	The blade trace is too deep and cuts into the backing paper.		Reduce
Check the shape of the square you have peeled off.	 The corners are not rounded and do not have "horns."	[Blade Offset]	No change
	 The corners are rounded.		Increase
	 The corners have "horns."		Reduce

8. Tap  or  to change the settings.

Cutting condition	Setting details	Default settings
[Blade Force]	Set the force (pressure) of the blade.	50 gf
[Cutting Speed]	Set the speed of cutting.	30 cm/s
[Blade Offset]	Set the blade offset. Enter the listed offset value for the blade. The offset value for the included blade is 0.250 mm (9.8 mil).	0.250 mm (0.010 in.)
[Rise Movement Speed]	Set the blade's up speed during cutting (the speed at which the blade travels when it moves to the next cutting line after cutting one cutting line). If the media comes loose during no-load feed and the blade damages the surface of the media, reduce the speed.	30 cm/s

9. Press [Save] to confirm your entry.
10. Repeatedly perform the cutting test and adjust the cutting conditions until the settings are optimized. Repeat steps 7 to 10 to adjust the cutting conditions.
11. Tap  to go back to the original screen.

3. Accurately Adjusting the Cutting-in Amount

When you want to perform accurate and fine adjustment of the cutting-in amount, such as when cutting media with thin backing paper, you can obtain good results by adjusting the amount of blade extension. Turn the cap portion of the blade holder to adjust the amount of blade extension. Each indicator tick corresponds to 0.1 mm (3.9 mil), and adjustment for 0.5 mm (19.7 mil) can be made by rotating the cap one full turn.

Note that making the amount of blade extension too small may cause the tip of the blade holder cap to touch the printed surface, soiling and damaging it. It is important to be especially careful about this when you are using media that has poor ink-adhesion properties.

The amount of blade extension (A) is 0 mm (0 in.) at minimum and 2.5 mm (98.42 mil) (C) at maximum.

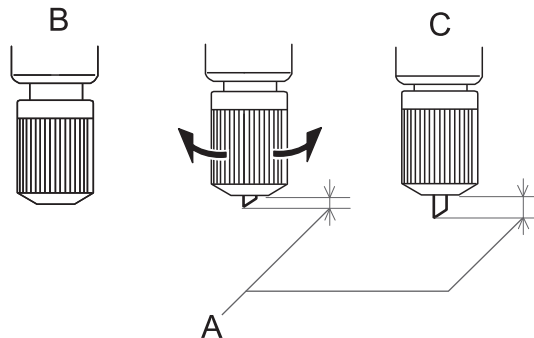

- **Rough Estimate for the Amount of Blade Extension (When Creating a Sticker)**

Set the amount of blade extension (A) to an amount that is the sum of the thickness of the material portion (D) and half (F) the thickness of the backing paper (E).

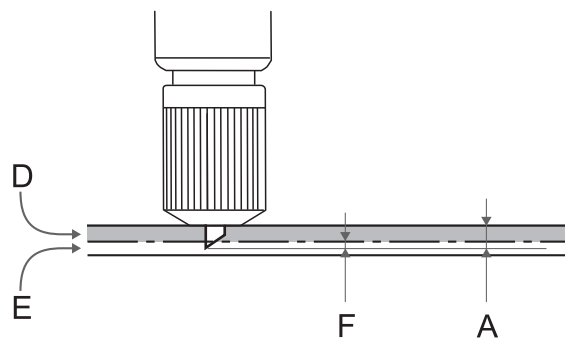

- **Rough Estimate for the Amount of Blade Extension (When Cutting Perforated Lines)**

Set the amount of blade extension (A) so that when the blade pierces the media (G), the blade tip extends slightly.

For information about the output settings for cutting perforated lines, refer to the documentation for VersaWorks.

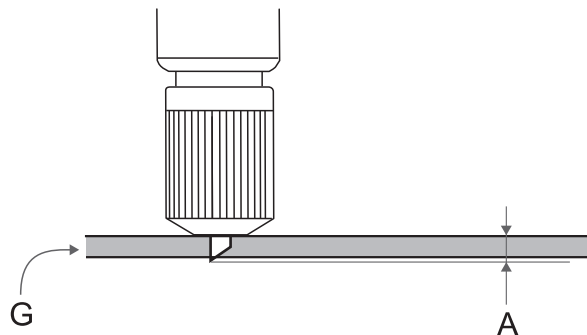

IMPORTANT

Pushing the blade out too far will damage the blade and blade protector and hasten their deterioration, so exercise caution.

Replacing the Separating Knife

If the separating knife becomes dull, replace it with the included replacement knife.

⚠ WARNING

Be sure to perform operations as specified by the instructions, and never touch any area not specified in the instructions.

Sudden movement of the machine may cause injury.



⚠ CAUTION

Do not touch the tip of the separating knife.

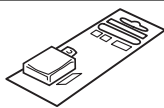
Doing so may result in injury.

Required item

Replacement blade for separating knife

Procedure

1. Remove any media.
2. Tap .
3. Tap [Maintenance]>[Separating Knife Replacement].
The [Separating Knife Replacement] screen appears.
4. Tap [Execute].
The cutting carriage moves to a position where separating knife replacement is possible.
5. Follow the instructions on the operation panel to replace the separating knife.
 - Tap  or  to check the procedure.
 - If you complete the work without viewing the instructions, tap [Finish All].

MEMO

Use the following procedure to remove the separating knife.

1. Loosen the screw until it slips out.
2. Grasp the screw portion, and slowly pull in the direction of the arrow.
When doing this, do not pull it back toward you.

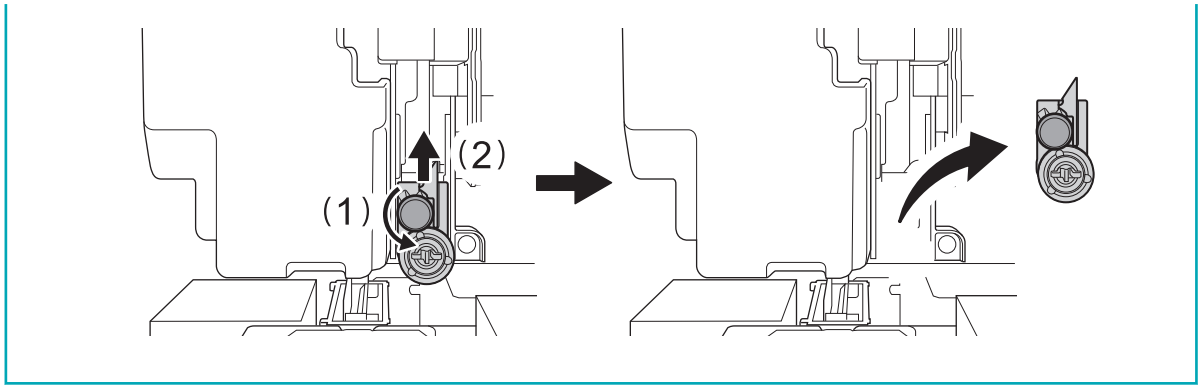

6. When the separating knife replacement is finished, tap [Finish All].
7. When [Close the cover.] appears, close the front cover.
When you close the front cover, you are returned to the original screen.
8. Tap  to go back to the original screen.

Consumable Parts That Require Inquiries before Replacement

When replacing the following consumable parts, contact your authorized Roland DG Corporation dealer.

Item	Related page
Print heads	P. 248 Cleaning around the Print Heads

Troubleshooting Methods

Output Quality Problems

Printed results are coarse or contain horizontal stripes.....	309
Do the print heads cause dot drop-out?	309
Is the print head height appropriate?	309
Have you carried out [Feed Correction] ?	309
Have you carried out [Media Gap Adjustment] (ink landing position correction)?.....	309
Is the printer installed in a level and stable location?	310
Is the print mode suitable?	310
Is the media loaded correctly?	310
Are the [Media Settings] appropriate?	310
The media becomes soiled when printed	311
Do the print heads come into contact with the media?.....	311
Are the print heads dirty?.....	311
Are the pinch rollers or the media clamps dirty?	311
Colors are unstable or uneven.....	312
Did you shake the ink cartridges before installing them?.....	312
Are colors still uneven after mixing the ink by shaking the ink cartridges?.....	312
Is the media wrinkled?	312
Was printing paused partway through?	313
Was cleaning performed during printing?.....	313
Is the printer installed in a level and stable location?	313
Is the media loaded correctly?	313
Are the operating parameters set to appropriate values?	313
Are the [Media Settings] appropriate?	313
Are the irradiation windows of the UV-LED devices dirty?.....	314
Cutting Is Misaligned, Skewed, or Not Clean	315
Is the media loaded correctly?	315
Are the settings for the cutting conditions appropriate?	315
Is the length of output too long?.....	315
Are you using media that exhibits large expansion and contraction?	315
Is the setting for the [Cutting Distance Correction] menu item (under [Cutting Settings]) correct?	315
Are the pinch rollers placed on the proper locations?.....	316
Have you corrected the misalignment of printing and cutting?.....	316
Is the blade holder installed appropriately?	316
Is the blade worn?.....	316
Is there any buildup of pieces of material or dust inside the blade holder?	316

Printed results are coarse or contain horizontal stripes

Do the print heads cause dot drop-out?

Carry out a printing test and make sure no dot drop-out or dot displacement occurs. If dot drop-out or dot displacement is present, perform head cleaning.

RELATED LINKS

- [P. 132 Performing a Nozzle Drop-out Test](#)
- [P. 134 Normal Cleaning Method](#)
- [P. 267 When Normal Cleaning Is Not Effective](#)

Is the print head height appropriate?

Printing when the [Print Head Height] menu item is set to [High] or to [Medium] is coarser than when set to [Low]. Keep this set to [Low] except when changing it is necessary, such as when you are using thick media.

RELATED LINKS

- [P. 172 Changing the Print Head Height](#)

Have you carried out [Feed Correction]?

Large misalignment in the amount of feed of the media may result in printing that seems coarse or contains horizontal bands. Either make the setting in the software RIP to match the type of media you are using, or make the setting for correction on the printer.

RELATED LINKS

- [P. 167 Automatically Making Required Adjustments](#)
- [P. 168 Manual Adjustment: Reducing Horizontal Bands \(Feed Correction\)](#)

Have you carried out [Media Gap Adjustment] (ink landing position correction)?

The optimal adjustment value varies depending on the thickness of the media. Set an adjustment value that is suitable for the media. When further correction is required, such as when adjustment made using [Simple Correction (Auto)] does not enhance printing, use [Detailed Correction (Manual)] to make the correction.

RELATED LINKS

- [P. 167 Automatically Making Required Adjustments](#)
- [P. 170 Manual Adjustment: Adjusting the Misalignment of the Ink Landing Position \(Media Gap Adjustment\)](#)

Is the printer installed in a level and stable location?

Never install the machine in a location where it is tilted or where it may wobble or experience vibration. Also make sure that the print heads are not exposed to moving air. These factors may lead to dot drop-out or reduced printing quality.

Is the print mode suitable?

If attractive printing is impossible, try using a higher-quality print mode. Depending on the media, smudging may occur when using a high-quality print mode, and results may also vary greatly depending on the settings of your software RIP (such as the color-profile selection). Select settings appropriate for the media you are using.

Is the media loaded correctly?

If the media is not loaded correctly or the media feed is not smooth, output may be adversely affected. Load the media correctly.

RELATED LINKS

- [P. 31 Setup of New Media](#)
- [P. 70 Setup of Registered Media](#)

Are the [Media Settings] appropriate?

If the settings are not suitable for the type of media, printing may be adversely affected. Choose settings optimized for the media you are using.

RELATED LINKS

- [P. 211 Changing the Media Settings](#)

The media becomes soiled when printed

Do the print heads come into contact with the media?

The height of the print heads may be too low. Also, if the media is not loaded and set up correctly, it may wrinkle or come loose and contact the print heads.

RELATED LINKS

- [P. 172 Changing the Print Head Height](#)
- [P. 31 Setup of New Media](#)
- [P. 70 Setup of Registered Media](#)

Are the print heads dirty?

The following may cause ink to drip on the media during printing.

- Buildup of fibrous dust (lint) around the heads
- Ink transferred to the heads due to rubbing against the media

If this happens, perform manual cleaning. We recommend carrying out periodic head cleaning.

- Too low humidity

Use the machine in an environment where the humidity is 35 to 80%RH (no condensation).

RELATED LINKS

- [P. 248 Cleaning around the Print Heads](#)

Are the pinch rollers or the media clamps dirty?

Periodically clean them.

RELATED LINKS

- [P. 246 Cleaning the Machine](#)

Colors are unstable or uneven

Did you shake the ink cartridges before installing them?

Shake new ink cartridges 50 times (about 20 seconds) before you install them.

Every day before starting work, remove the white ink cartridge, shake it 50 times (about 20 seconds), and then reinsert it.

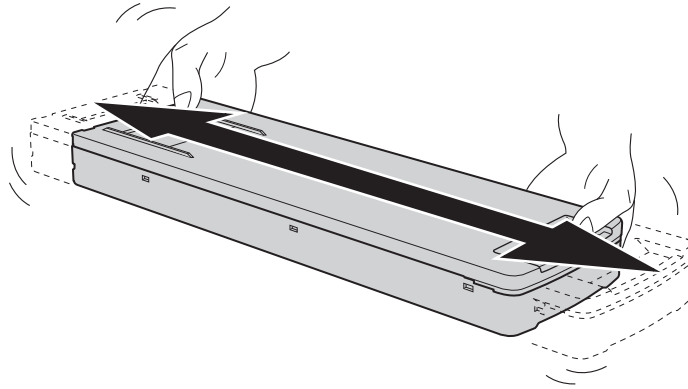

Are colors still uneven after mixing the ink by shaking the ink cartridges?

If uneven color issues with white ink still occur even after shaking the ink cartridges to mix the ink, perform **[Ink Circulation]**.

If uneven color issues with white ink still occur even after performing **[Ink Circulation]**, perform **[Powerful Cleaning]**.

If uneven color issues with white ink still occur even after performing **[Powerful Cleaning]**, perform **[Ink Renewal Inside Damper]**.

If uneven color issues with white ink still occur even after performing **[Ink Renewal Inside Damper]**, perform **[Ink Renewal]**.

If uneven color issues with ink other than white ink still occur even after shaking the ink cartridges to mix the ink, perform **[Ink Renewal]**.

RELATED LINKS

- [P. 271 Ink Circulating Method](#)
- [P. 273 Method for Ink Renewal Inside Damper](#)
- [P. 276 Ink Renewal Method](#)

Is the media wrinkled?

If the media is wrinkled and comes loose from the platen, colors may be uneven or the printing quality may suffer.

RELATED LINKS

- [P. 31 Setup of New Media](#)
- [P. 70 Setup of Registered Media](#)

Was printing paused partway through?

When printing is paused, the coloring at the seam may be altered when printing resumes. Avoid pausing printing. Before you perform lengthy printing, check the amount of ink remaining. Printing may also pause when data is not sent from the computer quickly enough. We recommend not performing any other tasks with the computer while printing is in progress.

Was cleaning performed during printing?

Performing cleaning during printing can affect the print quality. Check the time until cleaning and the printing time before printing.

RELATED LINKS

- [P. 207 Avoiding Printing Cancellation Due to Cleaning](#)

Is the printer installed in a level and stable location?

Never install the machine in a location where it is tilted or where it may wobble or experience vibration. Also make sure that the print heads are not exposed to moving air. These factors may lead to dot drop-out or reduced printing quality.

Is the media loaded correctly?

If the media is not loaded correctly or the media feed is not smooth, output may be adversely affected. Load the media correctly.

RELATED LINKS

- [P. 31 Setup of New Media](#)
- [P. 70 Setup of Registered Media](#)

Are the operating parameters set to appropriate values?

Depending on the settings for the [Printing Movement Range] and [Cleaning during Printing] menu items, uneven colors may occur. If the settings have been changed, try restoring them to their default values.

RELATED LINKS

- [P. 221 Speeding Up Output for Narrow Media](#)

Are the [Media Settings] appropriate?

If the settings are not suitable for the type of media, printing may be adversely affected. Choose settings optimized for the media you are using.

RELATED LINKS

- [P. 211 Changing the Media Settings](#)

Are the irradiation windows of the UV-LED devices dirty?

If the irradiation windows are dirty, this can reduce ink adhesion and the quality of the printed materials. Check the level of dirt and clean at the appropriate times.

RELATED LINKS

- [P. 256 Cleaning That Must Be Performed Once a Month or More](#)

Cutting Is Misaligned, Skewed, or Not Clean

Is the media loaded correctly?

If the media is not loaded correctly or the media feed is not smooth, output may be adversely affected. Load the media correctly.

RELATED LINKS

- [P. 31 Setup of New Media](#)
- [P. 70 Setup of Registered Media](#)

Are the settings for the cutting conditions appropriate?

Misalignment or skewing may occur if the cutting speed is too fast or the blade force is too high. Try changing the cutting conditions. With media having a strong adhesive layer, the adhesive layer reattaches to itself immediately after cutting. However, if a cutting test shows that the peeling of the media and the blade traces on the backing paper are optimal, the media is being cut properly. Be careful not to make the blade force too high.

RELATED LINKS

- [P. 183 Accurately Adjusting the Cutting Settings](#)

Is the length of output too long?

For printing followed immediately by cutting in particular, the longer the page length (that is, the longer the distance the media is returned after printing), the greater the chance of misalignment occurring. It is a good idea to keep the size of each single page to the minimum necessary.

Are you using media that exhibits large expansion and contraction?

When you are performing printing followed immediately by cutting, misalignment occurs if the media expands or contracts. If this happens, try performing printing with crop marks followed by cutting. The cutting position will be corrected to match the expansion and contraction of the media.

RELATED LINKS

- [P. 152 How to Cut with Crop Marks](#)

Is the setting for the [Cutting Distance Correction] menu item (under [Cutting Settings]) correct?

When you are performing printing followed immediately by cutting, go to [Cutting Settings] and set the [Cutting Distance Correction] correction value to 0.00%.

RELATED LINKS

- [P. 189 Performing Distance Correction during Cutting](#)

Are the pinch rollers placed on the proper locations?

Be sure to place the pinch rollers on the grit rollers. If the pinch rollers are not placed on the proper locations, misalignment of the media may occur.

RELATED LINKS

- [P. 31 Setup of New Media](#)
- [P. 70 Setup of Registered Media](#)

Have you corrected the misalignment of printing and cutting?

Misalignment between the printing and cutting positions may occur due to the thickness of the media or the head height. Make corrections for misaligned printing and cutting for the media you are using.

RELATED LINKS

- [P. 193 Accurately Adjusting the Settings for Printing and Cutting](#)

Is the blade holder installed appropriately?

When installing the blade holder, firmly tighten the screw and check that the blade holder is fixed in place.

RELATED LINKS

- [P. 298 Replacing the Blade](#)

Is the blade worn?

A worn or chipped blade will negatively affect the cutting quality. Check the status of the blade and replace it with a new one if necessary.

RELATED LINKS

- [P. 298 Replacing the Blade](#)

Is there any buildup of pieces of material or dust inside the blade holder?

Remove the blade holder, and then take off the tip of the blade holder and remove any pieces of material or dust inside.

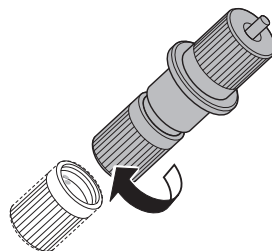

RELATED LINKS

- [P. 185 Accurately Adjusting the Cutting-in Amount](#)

Problems in Cutting with Crop Marks

Automatic Detection of Crop Marks Fails	318
Are the margins from the pinch rollers to the crop marks too small?	318
Is the media wrinkled or warped?	318
Is the media size too large?.....	318
Are you using media that is likely to reflect light?	318
Are you using transparent media?	318
Printing and Cutting Are Misaligned	319
Have you corrected the misalignment of printing and cutting with crop marks?	319

Automatic Detection of Crop Marks Fails

Are the margins from the pinch rollers to the crop marks too small?

If the margins are too small or the pinch roller locations are not correct, it may not be possible to detect the crop marks.

Check the margins and set the pinch rollers in the correct locations.

Is the media wrinkled or warped?

Wrinkled or warped media may cause crop mark detection to fail. Avoid using wrinkled or warped media.

RELATED LINKS

- [P. 206 Correcting the Reading Sensor](#)

Is the media size too large?

Large media may lead to large errors, which may cause crop mark detection to fail.

When you want to use lengthy media, we recommend performing output with the data separated into sizes that are as short as possible.

Are you using media that is likely to reflect light?

The machine may not be able to read crop marks from media that is likely to reflect light. Try [**Multi Sensor Adjustment**] (the correction function of the sensor for reading crop marks). If the crop marks still cannot be read, change the media you are using.

RELATED LINKS

- [P. 206 Correcting the Reading Sensor](#)

Are you using transparent media?

The machine cannot read crop marks from transparent media. Change the media you are using.

Printing and Cutting Are Misaligned

Have you corrected the misalignment of printing and cutting with crop marks?

Depending on the composition of the media, the positioning of printing and cutting may be misaligned even when you are using crop marks. Make corrections for misaligned printing and cutting for the media you are using.

RELATED LINKS

- [P. 198 Correcting the Misalignment of Printing and Cutting with Crop Marks \(Concurrent Test for Printing and Cutting with Crop Marks\)](#)
- [P. 201 Correcting the Misalignment of Printing and Cutting with Crop Marks \(Separate Test for Printing/Cutting with Crop Marks\)](#)

Media Feed Problems

Media Wrinkles or Shrinks	321
Is the media loaded and set up straight and securely?	321
Was loaded media allowed to stand for some time?	321
Are the media clamps installed?	321
Was the media loaded while the front heater was hot?	321
Is the temperature of the front heater too high?	321
Is the humidity of the room too high?	321
Is the media sagging?	321
Media Feeding Is Not Straight	322
Is the media loaded and set up straight and securely?	322
Media Feeding Is Not Smooth	323
Is some other object coming into contact with the media?	323
Is the media too thick?	323
Are the grit rollers dirty?	323
A Media Jam Occurs!	324
Is an error message displayed?	324
Is the media warped or wrinkled?	324
Is the height of the print heads too low?	324
Are the grit rollers dirty?	324
Are the media clamps installed?	324
Is the media loaded and set up straight and securely?	324
Is some other object coming into contact with the media?	325
Is the media too thick?	325

Media Wrinkles or Shrinks

Is the media loaded and set up straight and securely?

Feeding is not smooth when the media is not straight or is tensioned unevenly on the left and right. Reload the media.

RELATED LINKS

- [P. 31 Setup of New Media](#)
- [P. 70 Setup of Registered Media](#)

Was loaded media allowed to stand for some time?

Media may wrinkle if it is heated for an extended time. When printing ends, switch off the sub power and remove the media.

Are the media clamps installed?

When you are performing printing, be sure to install the media clamps.

Was the media loaded while the front heater was hot?

Loading media after the front heater has turned on and warmed up causes the temperature of the media to rise suddenly, which may cause the media to wrinkle during printing. Before loading media, switch off the sub power and allow the apron to cool.

RELATED LINKS

- [P. 178 Heating the Media to Prevent It from Coming Loose](#)

Is the temperature of the front heater too high?

Set the temperatures to suitable values for the type of media.

RELATED LINKS

- [P. 178 Heating the Media to Prevent It from Coming Loose](#)

Is the humidity of the room too high?

Use the machine in an environment with a humidity of 35 to 80%RH (no condensation). High humidity can cause the media to sag. If sagging media is used, it may come out wrinkled.

Is the media sagging?

If sagging media is used, it may come out wrinkled.

Media Feeding Is Not Straight

Is the media loaded and set up straight and securely?

Feeding is not smooth when the media is not straight or is tensioned unevenly on the left and right. Reload the media.

RELATED LINKS

- [P. 31 Setup of New Media](#)
- [P. 70 Setup of Registered Media](#)

Media Feeding Is Not Smooth

Is some other object coming into contact with the media?

Make sure the media does not touch anything else. This may affect output, even when the feed appears to be smooth.

RELATED LINKS

- [P. 31 Setup of New Media](#)
- [P. 70 Setup of Registered Media](#)

Is the media too thick?

Media that is too thick may not only cause an unstable feed but may scrape the print heads, resulting in a malfunction. Never use such media.

Are the grit rollers dirty?

Check to make sure the grit rollers are free of buildup of foreign material such as media scraps.

RELATED LINKS

- [P. 246 Cleaning the Machine](#)

A Media Jam Occurs!

Is an error message displayed?

If an error message is displayed because the media has jammed, immediately correct the problem. Doing so may damage the print heads.

RELATED LINKS

- [P. 344 \[Motor Error\]](#)

Is the media warped or wrinkled?

Many factors can cause warping or wrinkling. Refer to the following and correct the problem.

RELATED LINKS

- [P. 321 Media Wrinkles or Shrinks](#)

Is the height of the print heads too low?

Try raising the print heads higher. First, try setting the height to [**Medium**]. If the media is still jammed, change the height to [**High**]. Media may inevitably warp or wrinkle slightly, so adjust the height of the print heads to take this into account.

RELATED LINKS

- [P. 172 Changing the Print Head Height](#)

Are the grit rollers dirty?

Check to make sure the grit rollers are free of buildup of foreign material such as media scraps.

RELATED LINKS

- [P. 246 Cleaning the Machine](#)

Are the media clamps installed?

When you are performing printing, be sure to install the media clamps.

Is the media loaded and set up straight and securely?

Feeding is not smooth when the media is not straight or is tensioned unevenly on the left and right. Reload the media.

RELATED LINKS

- [P. 31 Setup of New Media](#)
- [P. 70 Setup of Registered Media](#)

Is some other object coming into contact with the media?

Make sure the media does not touch anything else. This may affect output, even when the feed appears to be smooth.

RELATED LINKS

- [P. 31 Setup of New Media](#)
- [P. 70 Setup of Registered Media](#)

Is the media too thick?

Media that is too thick may not only cause an unstable feed but may scrape the print heads, resulting in a malfunction. Never use such media.

Machine Problems

The Print Heads Do Not Move	327
What to Do First	327
If the Print Heads Still Do Not Move	327
The printer unit does not run.....	329
Is the power switched on?	329
Is [Output possible.] displayed?	329
Are any covers open?	329
Is the message [Output is currently paused.] displayed on the screen?	329
Is a message displayed on the screen?	329
Are the cables connected?	329
Is the LAN routing appropriate?	330
Are the LAN settings correct?	330
Did the software RIP end abnormally?	330
Is an [Ink Cartridge Error] displayed?	330
The Front Heater Does Not Become Hot	332
Has the media been set up?	332
Is [Front Heater] turned on?	332
Is the temperature of the room too low?	332
Cannot Separate the Media	333
Is the separating knife installed?	333

The Print Heads Do Not Move

If the print-head carriage stops over the platen, take action immediately to prevent the heads from drying out.

What to Do First

Switch the sub power off and then back on again. If the media is jammed, also remove the media.

If the print heads move to the home position (inside the right cover), it means the operation has ended successfully.

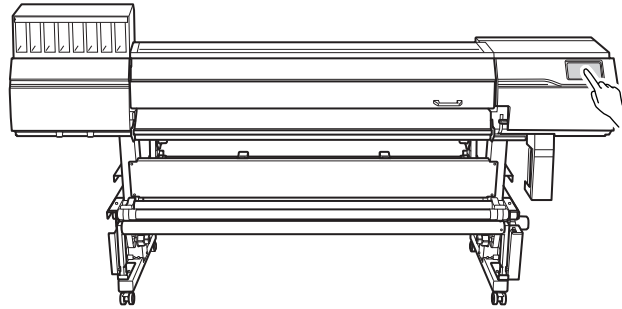

If the Print Heads Still Do Not Move

Try switching off the sub power, followed by the main power, then switching on the main power again, followed by the sub power.

If the Print Heads Still Do Not Move

If the heads still do not move, carry out the following emergency response measure, and then contact your authorized dealer.

Procedure

1. Switch off the sub power.
2. Switch off the main power, and then open the front cover.
3. Open the right cover.

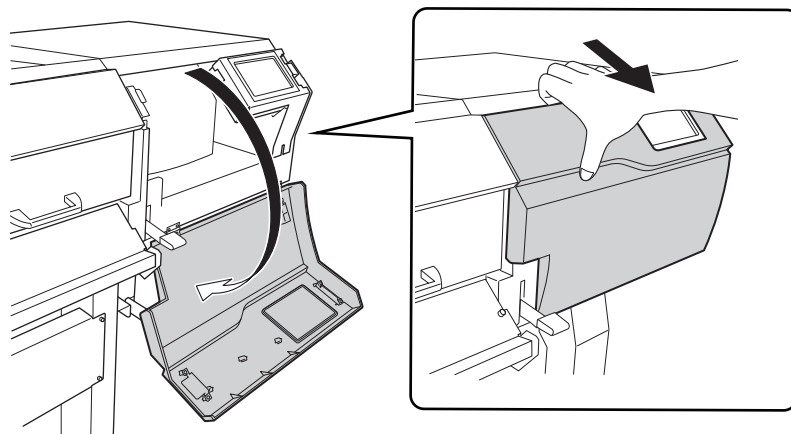

4. Gently move the print-head carriage to the home position by hand.

Stopping at the place where the audible click is heard locks the print-head carriage in place.

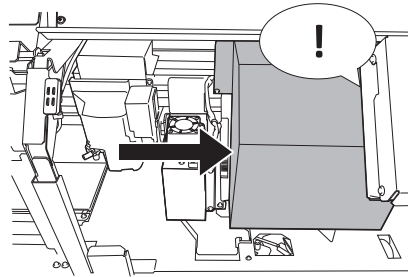

5. Gently apply pressure from the right side to make sure the print-head carriage does not move to the left. If the print-head carriage moves to the left, move it again slowly by applying pressure from the left side and make sure it locks in place.

The printer unit does not run



Is the power switched on?

Switch on the printer's main power, followed by the sub power and make sure the home screen appears.

RELATED LINKS

- [P. 27 Turning the Power On](#)

Is [Output possible.] displayed?

Output is not performed when [Output possible.] is not displayed at the top of the operation panel. After loading the media and lowering the loading lever, tap  [Setup]. Follow the instructions on the screen to finish setting up the media. Also, when operating the setting menu, output doesn't start when data is sent from the computer with some menu items. When you return to a menu item where output is possible or tap  to return to the home screen, output starts.

RELATED LINKS

- [P. 136 Starting Output](#)

Are any covers open?

Close the front, left, and right covers and the rear UV shield.

Is the message [Output is currently paused.] displayed on the screen?

When [Output is currently paused.] is displayed on the screen, operation is paused. To resume, tap [Resume].

RELATED LINKS

- [P. 107 Pausing and Canceling Output](#)

Is a message displayed on the screen?

RELATED LINKS

- [P. 335 Messages](#)
- [P. 341 Error Messages](#)

Are the cables connected?

Connect the cables securely.

RELATED LINKS

The printer unit does not run

- [LG-640 Setup Guide \(https://downloadcenter.rolanddg.com/LG-640\)](https://downloadcenter.rolanddg.com/LG-640)

Is the LAN routing appropriate?

Check whether or not the network routing is appropriate. Try connecting the computer and the machine to the same hub or connecting them directly using a cable. If this makes it possible to perform output, it means the problem may be in the network itself.

Are the LAN settings correct?

If the cable connections are secure and no problem is found in the network itself, make sure that the IP address and other such settings are appropriate. The settings on both the machine and the computer must be appropriate. Redo the settings, checking to ensure that the IP address does not conflict with the IP address for another device on the network, that the port setting for the software RIP specifies the IP address set on the machine, that the settings have no typing errors, and for other such problems.

RELATED LINKS

- [P. 233 Viewing Printer Information](#)
- [LG-640 Setup Guide \(https://downloadcenter.rolanddg.com/LG-640\)](https://downloadcenter.rolanddg.com/LG-640)

Did the software RIP end abnormally?

Make sure the software RIP is running correctly, then switch the sub power switch off and back on.

RELATED LINKS

- [VersaWorks manual \(https://downloadcenter.rolanddg.com/VersaWorks6\)](https://downloadcenter.rolanddg.com/VersaWorks6)

Is an [Ink Cartridge Error] displayed?

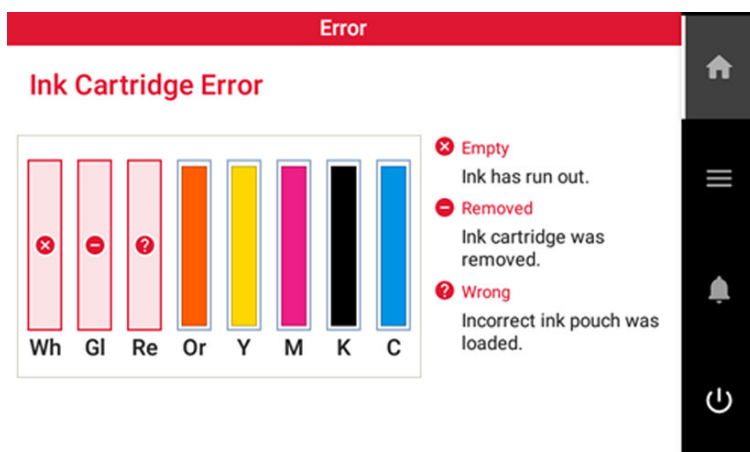

When an [Ink Cartridge Error] appears on the display screen, output data cannot be accepted. If there is data that has not yet been output remaining in the machine, output resumes when the error is cleared. If there is unsent data in the computer, output resumes when the data is resent.

When ink runs out

Replace the ink pouch in the ink cartridge with a new ink pouch.

When an ink cartridge with the incorrect color is loaded

Remove the ink cartridge that was loaded incorrectly and load the appropriate ink cartridge.

When an ink cartridge is removed or has not been securely loaded

Securely load the ink cartridge by pushing it all the way to the back.

RELATED LINKS

- [P. 114 Ink Replacement Method](#)
- [P. 341 \[Ink Cartridge Error\]](#)

The Front Heater Does Not Become Hot

Has the media been set up?

By default, simply switching on the power does not make the media heating system warm up to the preset temperature. Set up the media and wait for the machine to warm up.

RELATED LINKS

- [P. 178 Heating the Media to Prevent It from Coming Loose](#)

Is [Front Heater] turned on?

Set [Front Heater] to [On].

RELATED LINKS

- [P. 31 Setup of New Media](#)
- [P. 70 Setup of Registered Media](#)
- [P. 181 Setting the Output Heater Temperature](#)

Is the temperature of the room too low?

The front heater may not warm up sufficiently when the ambient temperature is less than 20°C (68°F). Also, even when the front heater reaches its set temperature, adequate effectiveness may not be apparent if the media is thoroughly chilled. Before printing, allow the media to come to room temperature.

Cannot Separate the Media

Is the separating knife installed?

If the separating knife is not installed, you cannot separate the media.

RELATED LINKS

- [P. 304 Replacing the Separating Knife](#)

Messages on the Operation Panel

Messages	335
[When output, cleaning, and other operations are completed, discard the discharged fluid.]	335
[The time for manual cleaning has arrived.]	335
[The time for wiper replacement has arrived.]	335
[The time for cap replacement has arrived.]	335
[The time for wiper cleaner replacement has arrived.]	335
[The time for UV mist filter replacement has arrived.]	336
[The time for flushing sponge replacement has arrived.]	336
[Print head protection mode has activated.]	336
[Replace the cleaning liquid pouch.]	336
[Install the cleaning liquid pouch.]	337
[Remaining cleaning liquid level low.]	337
[The time for ink mixing has arrived.]	337
[Operation of the take-up unit stopped.]	337
[Place the middle pinch rollers over all the grit rollers.]	338
[Install the media clamps correctly.]	338
[Media clamps could not be detected.]	338
[The LAN cable is not connected.]	339
[Connection is requiring too much time. Manually setting the IP address will improve the connection speed.]	339
[There is ink that has expired.]	339
[The media could not be detected automatically. Manually set the printing area.]	339
Error Messages	341
[Ink Cartridge Error]	341
[Cover Open Error]	341
[Media End Error]	341
[Pinch Lever Error]	341
[Media Loading Error]	342
[Drain Bottle Error]	342
[Crop Mark Detection Error]	342
[Unable to Fill Wiper Cleaning Liquid]	343
[Pinch Roller Error]	343
[Print Head Height Mismatch]	343
[Insufficient Media Width]	343
[Motor Error]	344
[Print Head Dry-out Error]	344
[Low Temperature Error]	344
[High Temperature Error]	344
[Pump Stop Error]	345
[Cleaning Error (Ink Cartridge)]	345
[Cleaning Error (Drain Bottle)]	345
[Take-up Unit Communication Error]	346
[Service Call]	346
[Software error]	346

Messages

These are the main messages that appear on the machine's display to prompt correct operation. These messages are not errors, so you can close them and perform other work. To check messages again or to carry out their corresponding actions, tap  to display the list of messages. Tap a message to display the menus and procedure required for the action. Perform operations according to the on-screen instructions.

[When output, cleaning, and other operations are completed, discard the discharged fluid.]

This message appears when a certain amount of discharged fluid collects in the drain bottle. Tap [When output, cleaning, and other operations are completed, discard the discharged fluid.]>[Execute] to discard this fluid.

RELATED LINKS

- [P. 262 If the Discharged Fluid Disposal Message Appears](#)

[The time for manual cleaning has arrived.]

This message appears when it is time to perform manual cleaning. Tap [The time for manual cleaning has arrived.]>[Execute] to perform manual cleaning.

RELATED LINKS

- [P. 126 Manual Cleaning Method](#)

[The time for wiper replacement has arrived.]

This message appears when it is time to replace the wiper. Tap [The time for wiper replacement has arrived.]>[Execute] to replace the wiper.

RELATED LINKS

- [P. 287 Replacing the Wiper](#)

[The time for cap replacement has arrived.]

This message appears when it is time to replace the print head caps. Tap [The time for cap replacement has arrived.]>[Execute] to replace the print head caps.

RELATED LINKS

- [P. 290 Replacing the Print Head Caps](#)

[The time for wiper cleaner replacement has arrived.]

This message appears when it is time to replace the wiper cleaner.

Tap [The time for wiper cleaner replacement has arrived.]>[Execute] to replace the wiper cleaner.

RELATED LINKS

- [P. 292 Replacing the wiper cleaner](#)

[The time for UV mist filter replacement has arrived.]

This message appears when it is time to replace the UV mist filters.

Tap [The time for UV mist filter replacement has arrived.]>[Execute] to replace the UV mist filters.

RELATED LINKS

- [P. 294 Replacing the UV Mist Filters](#)

[The time for flushing sponge replacement has arrived.]

This message appears when it is time to replace the flushing sponge.

Tap [The time for flushing sponge replacement has arrived.]>[Execute] to replace the flushing sponge.

RELATED LINKS

- [P. 296 Replacing the Flushing Sponge](#)

[Print head protection mode has activated.]

This message appears when the ink in use may not be a product specified by Roland DG Corporation.

If the ink is not a product specified by Roland DG Corporation, a larger amount of ink will be consumed, and drying will be performed frequently. To obtain optimal performance, we recommend that you use ink specified by Roland DG Corporation. To purchase ink, contact your authorized Roland DG Corporation dealer.

[Replace the cleaning liquid pouch.]

This message appears when the cleaning liquid runs out.

Replace the empty cleaning liquid pouch.

When you replace the cleaning liquid pouch, the message [Has the cleaning liquid pouch been replaced? Tap "Yes" to reset the amount of remaining cleaning liquid.] appears.

Tap [Yes] to reset the amount of cleaning liquid remaining and identify the cleaning liquid pouch as a new product.

MEMO

If you tap [Yes] on the cleaning liquid pouch replacement confirmation screen even though you have not replaced the cleaning liquid pouch, the amount of cleaning liquid remaining is reset. In this situation, no notification will appear even if the amount of cleaning liquid remaining is very small, and the message [Replace the cleaning liquid pouch.] will appear when the cleaning liquid runs out. To ensure you have enough time to prepare the replacement cleaning liquid, tap [No] if you have not replaced the cleaning liquid.

RELATED LINKS

- [P. 120 Cleaning Liquid Replacement Method](#)

[Install the cleaning liquid pouch.]

This message appears when a cleaning cartridge that does not contain a cleaning liquid pouch is loaded or when the cleaning cartridge is removed from the machine.

Correctly load a new cleaning liquid pouch into the cleaning cartridge and insert this cartridge into the machine. If the cleaning cartridge was removed from the machine, quickly insert it.

When you insert the cleaning cartridge, the cleaning liquid pouch replacement confirmation screen appears.

- If you have replaced the cleaning liquid pouch, tap **[Yes]**. The amount of cleaning liquid remaining is reset.
- If you have not replaced the cleaning liquid pouch, tap **[No]**. The amount of cleaning liquid remaining is not changed.

MEMO

If you tap **[Yes]** on the cleaning liquid pouch replacement confirmation screen even though you have not replaced the cleaning liquid pouch, the amount of cleaning liquid remaining is reset. In this situation, no notification will appear even if the amount of cleaning liquid remaining is very small, and the message **[Replace the cleaning liquid pouch.]** will appear when the cleaning liquid runs out. To ensure you have enough time to prepare the replacement cleaning liquid, tap **[No]** if you have not replaced the cleaning liquid.

RELATED LINKS

- [P. 120 Cleaning Liquid Replacement Method](#)

[Remaining cleaning liquid level low.]

This message appears when the remaining cleaning liquid level is low.

The cleaning liquid can be used until it runs out, so it does not need to be replaced immediately. However, printing is not possible if there is no cleaning liquid. If this message appears, prepare a replacement cleaning liquid pouch.

[The time for ink mixing has arrived.]

This message appears when it is time to mix the ink.

When **[Ink Mixing Notification]** accessed with **[Preferences]>[Notifications On/Off]** is on, this message appears when 1 day elapses from the last time the ink was mixed.

When the message **[The time for ink mixing has arrived.]** appears, tap **[OK]** to clear the message.

Tap  then **[The time for ink mixing has arrived.]** to display a confirmation screen.

Remove the white ink cartridge, shake it 50 times (about 20 seconds), and then reinsert this cartridge. On completion, tap **[Yes]**.

[Operation of the take-up unit stopped.]

This message appears and the take-up unit stops when it is not possible to detect the position of the dancer roller for a continuous length of time during media feeding or pull back.

When the message **[Operation of the take-up unit stopped.]** appears, tap **[OK]** to clear the message.

Tap  followed by [Operation of the take-up unit stopped.] and follow the instructions on the screen to recover the take-up unit.

[Place the middle pinch rollers over all the grit rollers.]

This message appears when the middle pinch rollers have not been properly placed. Position these pinch rollers properly between the left and right pinch rollers.

RELATED LINKS

- [P. 31 Setup of New Media](#)
- [P. 70 Setup of Registered Media](#)

[Install the media clamps correctly.]

This message appears when the media clamps are not placed at the predetermined positions.

Check the loading status of the media and that the pinch rollers have been positioned correctly, and then correctly set the media clamps at the ends of the media.

RELATED LINKS

- [P. 31 Setup of New Media](#)
- [P. 70 Setup of Registered Media](#)

[Media clamps could not be detected.]

This message appears when the media clamps cannot be detected because they are hidden by the media.

Check the loading status of the media and that the pinch rollers have been positioned correctly, and then correctly set the media clamps at the ends of the media.

This message appears when the media clamps cannot be detected because their parts that are read are dirty with, for example, ink.

Use cleaning liquid and a cleaning stick to clean the white parts on the media clamps.

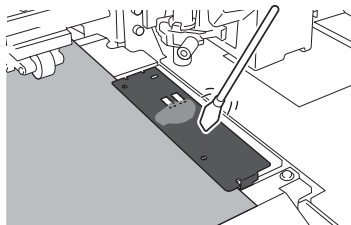

It may not be possible to detect the media clamps because the multi sensor is dirty with ink due to reasons such as the media striking it immediately after printing.

Install the media clamps correctly and clean their parts that are read. If this message still appears, contact your authorized Roland DG Corporation dealer.

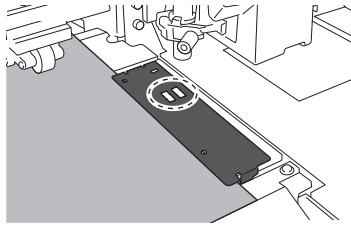

RELATED LINKS

- [P. 31 Setup of New Media](#)
- [P. 70 Setup of Registered Media](#)

[The LAN cable is not connected.]

This message appears when the machine and a computer are not connected with a LAN cable. Properly connect the LAN cable.

[Connection is requiring too much time. Manually setting the IP address will improve the connection speed.]

This message appears when automatic IP address acquisition is enabled and the machine connects to a network on which no DHCP server exists while this automatic acquisition is in progress.

Connect to a network on which a DHCP server exists or disable automatic IP address acquisition and set a fixed IP address.

[There is ink that has expired.]

Ink has expired.

Replace with an ink pouch that is within its expiration date.



RELATED LINKS

- [P. 114 Ink Replacement Method](#)

[The media could not be detected automatically. Manually set the printing area.]



This message appears when media with high reflectance is set up. Manually set the printing area.

Procedure

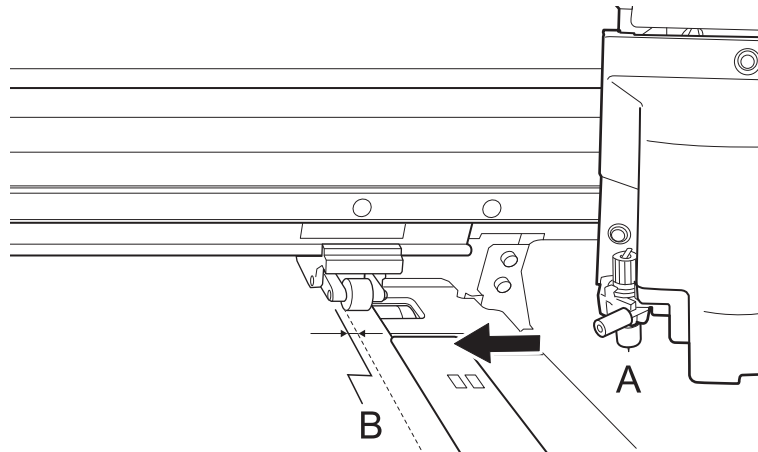
1. Tap [OK] on the screen displaying the above message.
2. Tap [Change].
The [Set the right edge of the printing area within the area specified by the pinch rollers.] screen appears.
3. Hold down  or  to move the center of the blade (A) approximately 2 mm (0.08 in.) to the inside (B) from the left edge of the right pinch roller.



4. Tap [OK].
The [Set the left edge of the printing area within the area specified by the pinch rollers.] screen appears.

5. Hold down  or  to move the center of the blade (A) approximately 2 mm (0.08 in.) to the inside (B) from the right edge of the left pinch roller.

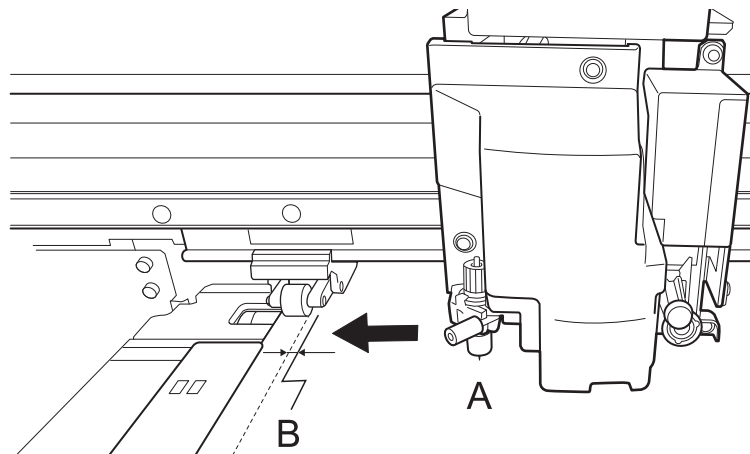

6. Tap [OK].
The set left and right positions are applied to the [Printing Area (Width)].

7. Tap [OK].

Error Messages

This section describes the error messages that may appear on the machine's display and how to take action to remedy the problem.

Follow the instructions on the screen to clear the error or switch the power off before starting to operate the machine again.

If the action displayed on the screen does not correct the problem or if an error message not described here appears, contact your authorized dealer.

[Ink Cartridge Error]

This message appears when one of the following ink cartridge errors is detected.

MEMO

When an error occurs, the , , or  icon is displayed next to the corresponding ink cartridge on the screen.

Implement appropriate countermeasures according to the error.

- **When ink runs out**

 **[Empty]**[Ink has run out.]

Replace the ink pouch with a new one, and then load the ink cartridge.

- **When an ink cartridge is removed**

 **[Removed]**[Ink cartridge was removed.]

Load the removed ink cartridge.

- **When an ink cartridge with the incorrect color is loaded**

 **[Wrong]**[Incorrect ink pouch was loaded.]

Remove the incorrectly loaded ink cartridge, and then load the correct ink cartridge.

When an ink cartridge is removed,  **[Removed]**[Ink cartridge was removed.] is displayed.

[Cover Open Error]

The front, right, or left cover or the rear UV shield is open.

For safety, the machine stops if a cover is opened during operation.

Close the open cover.

[Media End Error]

This message appears when one of the following situations is detected.

- Insufficient remaining media during take-up unit setup or printing output
- No media during media feeding

Switch to new media, and then send the data again.

[Pinch Lever Error]

The loading lever was raised during media setup or after completing this setup.

Lower the loading lever and redo setup.

[Media Loading Error]

This message appears when [Media Edge Detection] is set to [Enable] and media has not been fed with the pinch rollers set incorrectly.

Raise the loading lever, set the pinch rollers correctly, and then set up the media again.

This message appears when [Media Edge Detection] is set to [Enable] and the media is too short.

The media is not long enough to be detected. Raise the loading lever, set [Media Edge Detection] to [Disable], and then set up the media again.

For the setup method when [Media Edge Detection] is set to [Disable], refer to [1. B: Determining the Positions of Media \(If \[Media Edge Detection\]: \[Disable\]\)\(P. 61\)](#).

RELATED LINKS

- [P. 31 Setup of New Media](#)
- [P. 70 Setup of Registered Media](#)

[Drain Bottle Error]

This message appears when the drain bottle has reached its limit for discharged fluid.

Discard the discharged fluid in the drain bottle, and then attach this bottle again.

MEMO

When the drain bottle is detached, the error message changes to [Install the drain bottle.].

This message appears when the drain bottle is misaligned.

Install the drain bottle again.

[Crop Mark Detection Error]

[Crop marks could not be detected.]

Automatic detection of crop marks could not be accomplished.

Try to make corrections using [Multi Sensor Adjustment] (the correction function of the sensor for reading crop marks). Depending on the media, it may not be possible to detect crop marks automatically.

[Crop marks were detected however the size or position was incorrect.]

Automatic detection of crop marks could not be accomplished.

Check the data output settings. Then, load the media at the correct position and perform detection of crop marks again. If repeating automatic crop-mark detection also results in an error, start over again from the printing of crop marks.

RELATED LINKS

- [P. 31 Setup of New Media](#)
- [P. 70 Setup of Registered Media](#)
- [P. 152 How to Cut with Crop Marks](#)
- [P. 206 Correcting the Reading Sensor](#)

[Unable to Fill Wiper Cleaning Liquid]

The cleaning liquid pouch in the cleaning cartridge is empty.
Quickly replace this cleaning liquid pouch with a new one.

[Pinch Roller Error]

The left (right) pinch roller is positioned at a location where it cannot pinch the media.
Raise the loading lever and move the pinch roller to the correct location.

RELATED LINKS

- [P. 31 Setup of New Media](#)
- [P. 70 Setup of Registered Media](#)

[Print Head Height Mismatch]

The set print head height and the actual print head height are different.

Follow the instructions on the screen to change the print head height. When you change this height, [OK] is displayed on the screen. Tap [OK] to resume printing.

If 10 minutes elapse after the print head carriage moves, this carriage is capped and the data is canceled to prevent the heads from drying out.

RELATED LINKS

- [P. 172 Changing the Print Head Height](#)

[Insufficient Media Width]

[The print data is larger than the media width. Continue output?]

This message appears when the size of the printing data is larger than the width of the loaded media.

To continue performing output without making corrections, tap [Continue Output]. At this time, the portion extending beyond the printing area is not output.

To cancel output, tap [Cancel]. Check the data output settings, and then send the data again.

[Crop marks cannot be added because the print data is larger than the media width. Continue output?]

This message appears when one of the following situations is detected.

- The size of the printing data with crop marks is larger than the width of the loaded media.
- The width of the printing data is 60 mm (2.36 in.) or less.

To continue performing output without making corrections, tap [Continue Output]. The data is output without printing the crop marks.

To cancel output, tap [Cancel]. Check the data output settings, and then send the data again.

The size of the data being output is too small.

The horizontal-direction (scan-direction) size of the data should be at least 61 mm (2.41 in.). To continue performing output without making corrections, tap [Continue Output]. At this time, the data is output without printing the crop marks.

To cancel output, tap [Cancel]. Increase the size of the data, and then send the data again.

[Motor Error]

A motor error occurred.

Operation cannot be continued. Turn off the sub power. Next, eliminate the cause of the error, then immediately switch on the sub power.

If the machine is allowed to stand with the error uncorrected, the print heads may dry out and become damaged. This error may be caused by such factors as a mistake in loading the media, a media jam, or an operation that pulls the media with excessive force.

The media has jammed.

Carefully remove the jammed media. The print heads may also be damaged. Perform head cleaning, and then perform a printing test and check the results.

Has the media been pulled with excessive force?

Excessive tension was applied to the media, and additional action is necessary to recover from this state. First, raise the loading lever and adjust the media to create a small amount of slack, and then switch on the sub power.

[Print Head Dry-out Error]

This message appears when the print heads are forced to the home position to prevent them from drying out.

Operation cannot be continued. Switch the sub power off, and then back on.

[Low Temperature Error]

The internal temperature of the machine has fallen below that at which it can operate.

This message appears when the temperature falls to 16°C (60.8°F) or lower during startup or to 14°C (57.2°F) or lower during operation.

Operation cannot be continued. Turn off the sub power.

Bring the installed location to a temperature at which operation is possible (20°C to 32°C [68°F to 89.6°F]), allow the machine to come to room temperature, and then turn on the power.

RELATED LINKS

- [P. 27 Power Supply Operations](#)

[High Temperature Error]

The internal temperature of the machine has risen above that at which it can operate.

This message appears when the temperature rises to 45°C (113°F) or higher during startup or to 50°C (122°F) or higher during operation (when recovering from sleep mode).

Operation cannot be continued. Turn off the sub power.

Bring the installed location to a temperature at which operation is possible (20°C to 32°C [68°F to 89.6°F]), allow the machine to come to room temperature, and then turn on the power.

RELATED LINKS

- [P. 27 Power Supply Operations](#)

[Pump Stop Error]

This message appears when an ink cartridge is pulled out during pump operation, such as during cleaning, or when the machine has no ink for 10 minutes or more.

Operation cannot be continued. Switch the sub power off, and then back on.

[Cleaning Error (Ink Cartridge)]

The printer made an emergency stop for one of the following reasons.

- Ink ran out during "Ink Renewal Inside Damper."
- An ink cartridge was pulled out during "Ink Renewal Inside Damper."
- An ink cartridge was pulled out during the initial ink filling.

Operation cannot be continued. Perform the following operations.

1. Check that the ink cartridges are inserted and that there is sufficient ink.
2. Switch the sub power off and back on.
3. Perform [Ink Renewal Inside Damper] or fill the machine with ink.

MEMO

If the printer stopped partway through [Ink Renewal Inside Damper], perform [Ink Renewal] for the group ("A" or "B") with the white ink, and then perform [Ink Renewal Inside Damper] again. The space from "A" to "B" is [Group A]. The space from "B" to the right side is [Group B].

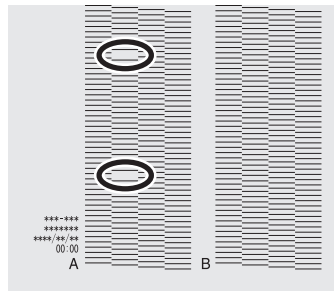

If the printing-test results are difficult to interpret

Check the results in a bright location, changing your line of vision. They are visible using the reflection of the light.

If an Ink Cartridge Error appears during work, remove and reinsert the corresponding ink cartridge.

RELATED LINKS

- [P. 273 Method for Ink Renewal Inside Damper](#)

[Cleaning Error (Drain Bottle)]

This message appears when one of the following situations is detected.

- The drain bottle is removed during execution of "Ink Renewal Inside Damper."
- The drain bottle is removed during initial ink filling.

Operation cannot be continued. Perform the following operations.

1. Check that the ink cartridges are inserted and that there is sufficient ink.
2. Switch the sub power off and back on.
3. Perform [Ink Renewal Inside Damper] or fill the machine with ink.

MEMO

If the printer stopped partway through [Ink Renewal Inside Damper], perform [Ink Renewal] for the group ("A" or "B") with the white ink, and then perform [Ink Renewal Inside Damper] again. The space from "A" to "B" is [Group A]. The space from "B" to the right side is [Group B].

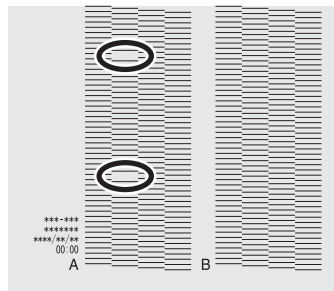

If the printing-test results are difficult to interpret

Check the results in a bright location, changing your line of vision. They are visible using the reflection of the light.

If an Ink Cartridge Error appears during work, remove and reinsert the corresponding ink cartridge.

[Take-up Unit Communication Error]

This message appears when an error such as the connection being lost during take-up unit setup occurs.

Operation cannot be continued. Switch off the sub power, followed by the main power. Check that the take-up unit is properly connected, and then once more switch on the main power, followed by the sub power.

[Service Call]

An unrecoverable error occurred or part replacement that must be performed by a service technician is required.

Note the number displayed on the operation panel, and then switch off the sub power. After turning the power off, contact your authorized Roland DG Corporation dealer.

[Software error]

An error occurred in the internal communication or applications of the machine or part replacement that must be performed by a service technician is required.

Switch off the main power. Then, switch on the main power again, followed by the sub power. If the error still occurs, contact your authorized Roland DG Corporation dealer.

Appendix

Operations When Moving the Unit

Preparing to Move the Machine.....	349
Step 1: Removing Media and the Blade Holder	349
Step 2: Circulating the Ink (Only When Using White Ink)	351
Step 3: Discarding the Discharged Fluid	352
Step 4: Secure the print heads in place using the retainer.	354
Step 5: Reinstalling the Machine	356

Preparing to Move the Machine

Before moving the machine, dispose of the discharged fluid and secure the print heads in place. Also, if you are using white ink, you will have to manually circulate it. Attempting to move the machine without first performing these preparations may result in damage to internal components due to leaking ink or damage to the print heads.

IMPORTANT

- Once the preparations for moving the machine are complete, move the machine promptly and turn on the machine as soon as possible after the machine is relocated. If you leave the machine alone without turning it on, the precipitated ink will coagulate and result in problems such as the clogging of the print heads.
- When moving the machine, keep it at a temperature from 5 to 40°C (41 to 104°F) and at a humidity from 20 to 80%RH (with no condensation). Failure to do so may result in a breakdown.
- Handle the machine with care when moving it, keeping it level (not tilted at an angle) and preventing it from striking other objects.

Step 1: Removing Media and the Blade Holder

MEMO

The procedure for replacing the blade is displayed on the operation panel, but this section only describes the work for removing the blade.

Procedure

1. Remove any media.

If any media has been loaded, remove it.

If no media is loaded, raise the loading lever.

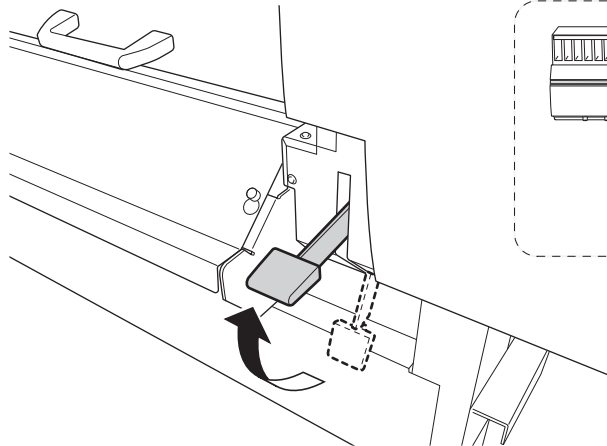

2. Tap .

3. Tap [Maintenance]>[Blade Replacement].

The [Blade Replacement] screen appears.

4. Tap [Execute].

The cutting carriage moves to a position where blade replacement is possible.



5. When [Open the front cover.] appears, open the front cover.
6. Detach the blade holder.
7. Tighten the screw.
8. Tap [Finish All].
9. Close the front cover.
10. Tap  to go back to the original screen.

Step 2: Circulating the Ink (Only When Using White Ink)

* This operation is not required for the ink types shown below.

- Four colors: CMYK

Procedure

1. Tap .
2. Tap [Maintenance]>[Ink Circulation].
The [Ink Circulation] screen appears.
3. Tap [Execute].
Ink circulation starts.
4. Tap  to go back to the original screen.

Step 3: Discarding the Discharged Fluid

Procedure

1. Tap .
2. Tap [Maintenance]>[Drain Bottle].
3. Tap [Execute].
4. Remove the drain bottle and discard the discharged fluid.

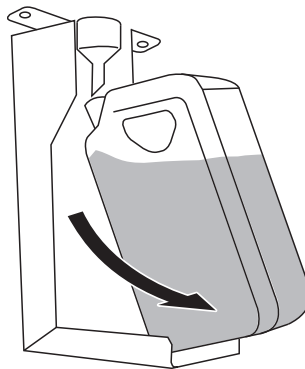

IMPORTANT

When you remove the drain bottle, a few drops of discharged fluid may come out of the machine. Exercise caution to prevent this fluid from soiling your hands or the floor.

⚠ WARNING

Never place discharged fluid or ink near an open flame.

Doing so may cause a fire.

⚠ CAUTION

To store discharged fluid temporarily, place it in the included drain bottle or in a durable sealed container such as a metal can or polyethylene tank, and cap the container tightly.

Any spillage or vapor leakage may cause fire, odor, or physical distress.

IMPORTANT

Dispose of discharged fluid properly, in accordance with the laws in effect in your locale.

Discharged fluid is flammable and contains toxic ingredients. Never attempt to incinerate discharged fluid or discard it with ordinary trash. Also, do not dispose of it in sewer systems, rivers, or streams. Doing so may have an adverse impact on the environment.

5. Quickly attach the emptied drain bottle to the machine once more.
6. Tap [Finish].
7. Switch off the sub power.

8. Turn off the main power switch.

Step 4: Secure the print heads in place using the retainer.

Procedure

1. Open the left cover.

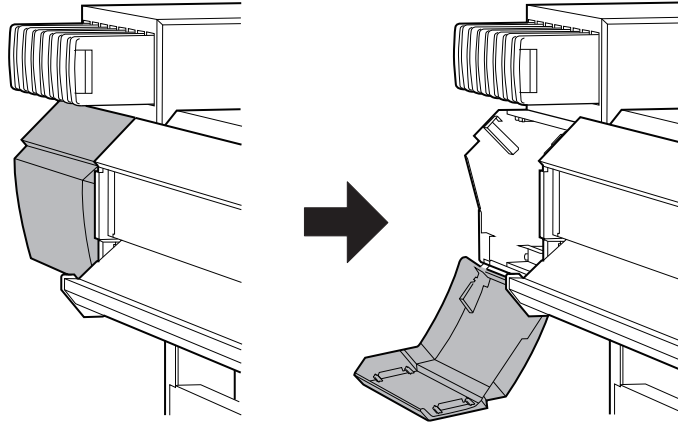

2. Remove retainer C.

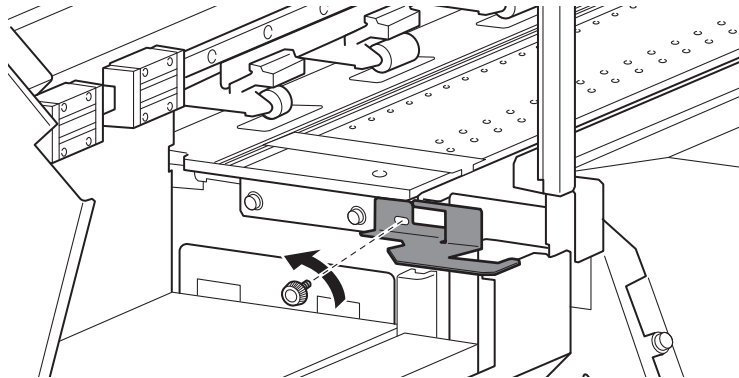

3. Open the front cover.

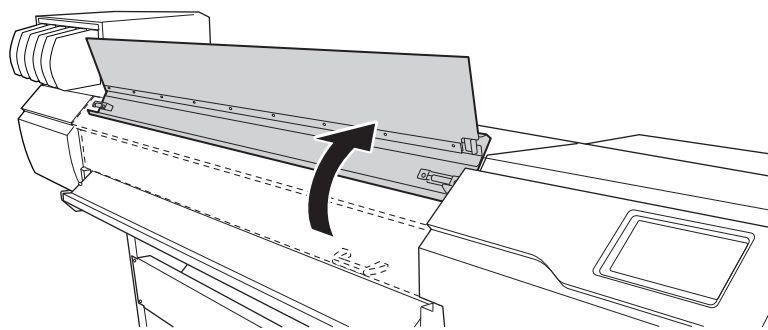

4. Secure the print heads using retainer C, which you removed above.

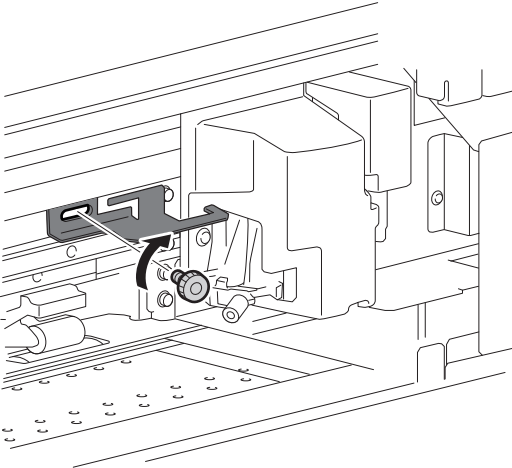

5. Close the front and left covers.

Step 5: Reinstalling the Machine

Procedure

1. Once the preparations are complete, move the machine with as little delay as possible.
2. Immediately reinstall the machine, and then open the front cover.

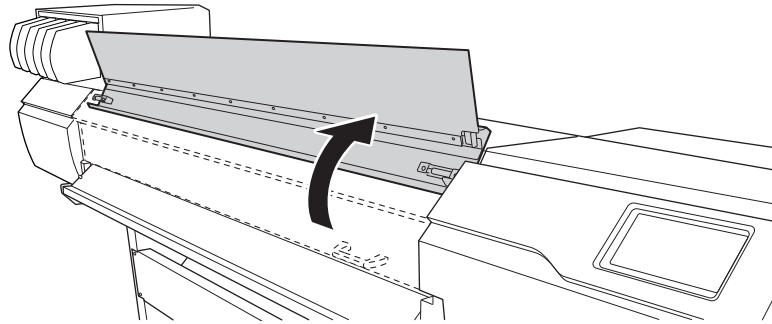

3. Remove retainer C, which secures the print heads in place.

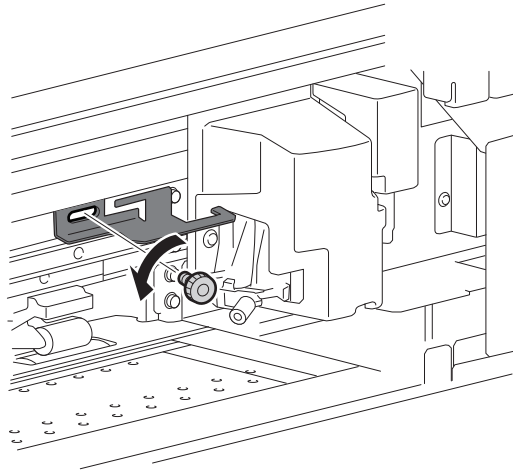

4. Open the left cover.

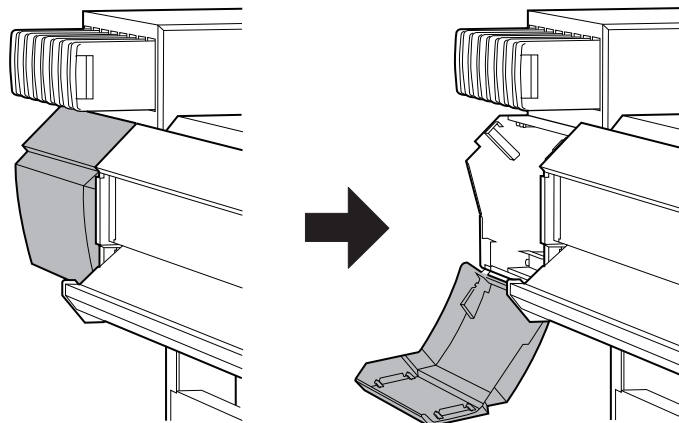

5. Install retainer C at the position indicated in the figure for storage.

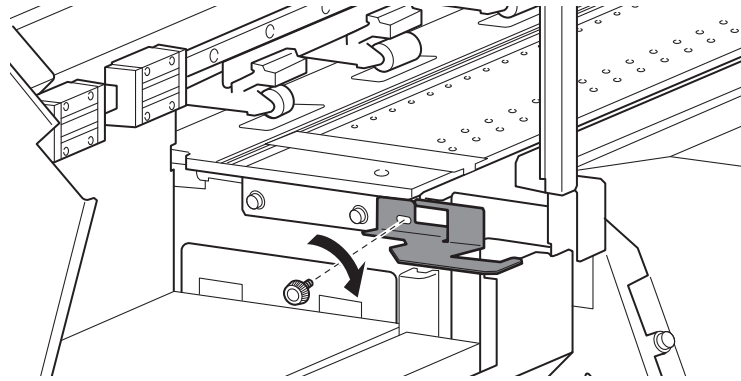

6. Close the front and left covers.

7. Turn on the main power switch.

IMPORTANT

To prevent the print heads from being damaged, move the machine with as little delay as possible and switch on the main power as soon as possible after moving the machine. To install the machine again, follow the procedure in the Setup Guide.

8. Press the sub power button.
The home screen appears.

RELATED LINKS

- [P. 120 Cleaning Liquid Replacement Method](#)

Main Specifications

- Printing/Cutting Area 359
 - Maximum Area 359
 - Maximum Printing Area When Using Crop Marks..... 360
 - Media Separation Location during Continuous Printing..... 361
- About the Blade..... 362

Printing/Cutting Area

Maximum Area

The printing or cutting area along the horizontal plane (the direction in which the carriages move) is determined by the position of the pinch rollers.

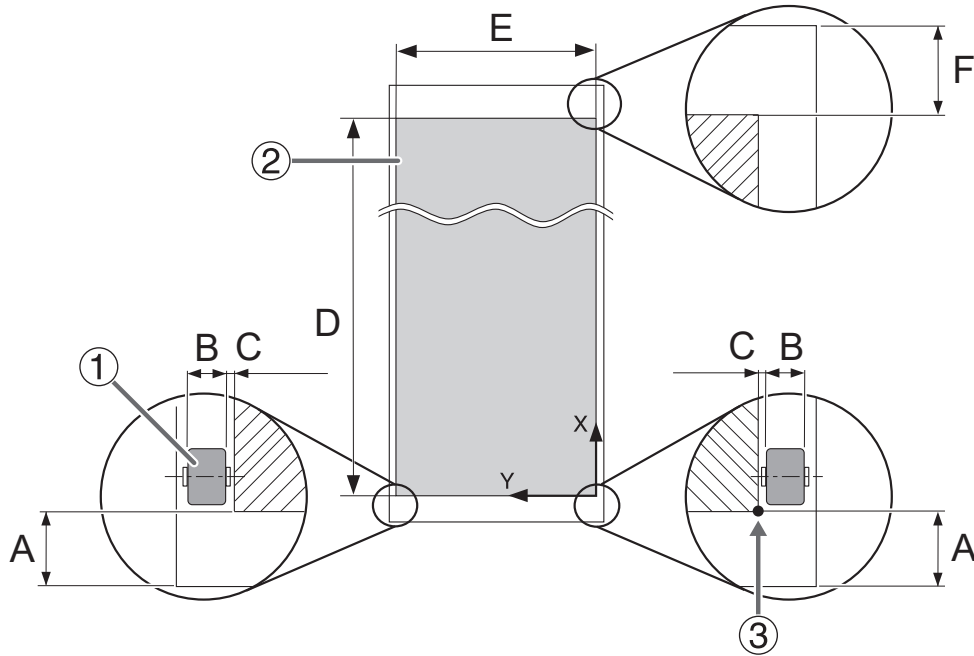

①	Pinch roller
②	Printing or cutting area
③	Printing or cutting coordinates origin (0,0)
A	75 mm (3 in.)
B	10 mm (0.4 in.)
C	1.5 mm (0.06 in.)
D	Max. 24,998 mm (984.2 in.)
E	64-inch model: Max. 1,600 mm (62.9 in.) 54-inch model: Max. 1,346 mm (52.9 in.) 30-inch model: Max. 736 mm (29 in.)
F	Max. 220 mm (8.66 in.)

Maximum Printing Area When Using Crop Marks

The maximum printing area when crop marks are used is reduced from the maximum printing area when crop marks are not used by an amount equal to the crop marks.

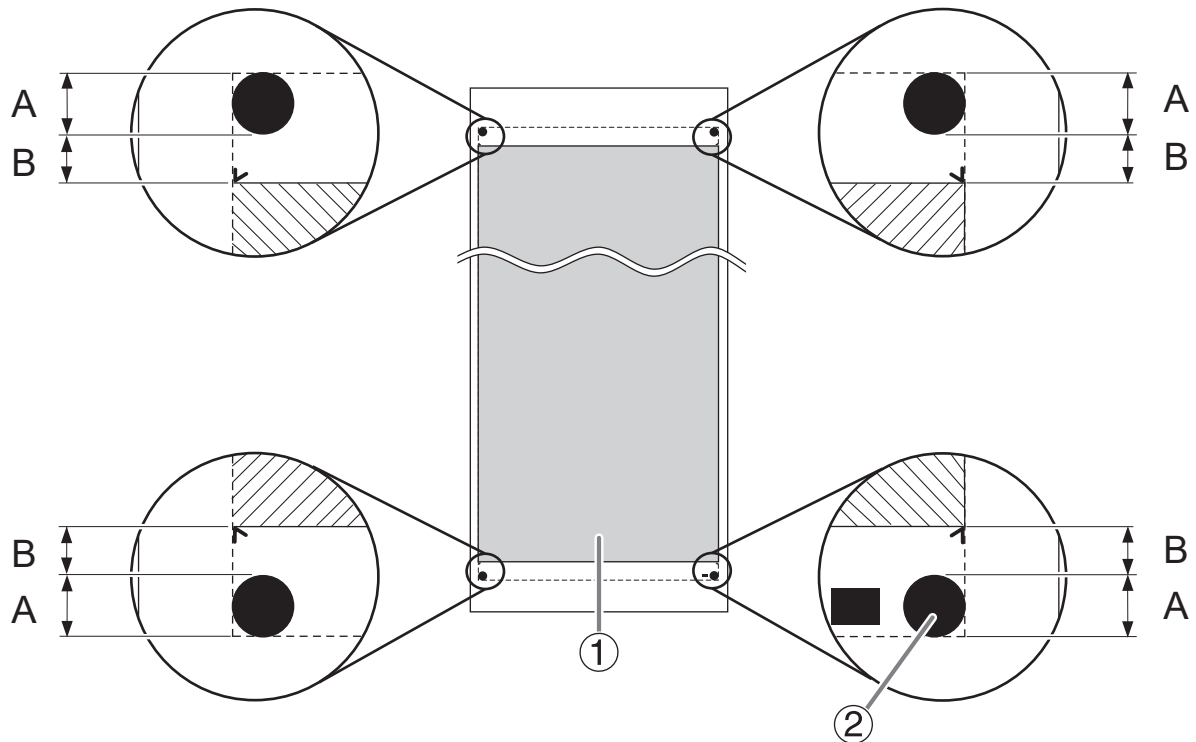

①	Maximum printing area
②	Crop mark
A	12.5 mm (0.5 in.)
B	10 mm (0.4 in.)

Media Separation Location during Continuous Printing

When a command for separating the media is sent from the computer, the separation location on the media is as shown in the figure below.

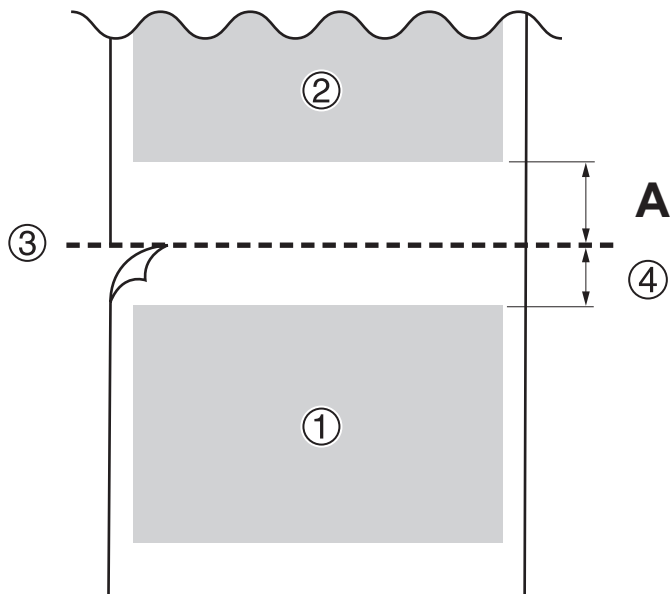

①	First page
②	Second page
③	Separation location
④	Margin (software RIP value)
A	75 mm (3 in.)

About the Blade

The cutting conditions and the service life of the blade change according to the media and the operating environment, even when you're using identical blades. The service life also differs according to the type of blade. A rough guide is shown below.

Blade	Media	Blade force	Amount of blade offset (amount of blade tip correction)	Blade life (general guide) ^{*1}
ZEC-U5032	General Signage Vinyl	30 to 100 gf	0.25 mm (0.01 in.)	8,000 mm (26,246.7 ft.)
ZEC-U5025	General Signage Vinyl	30 to 100 gf	0.25 mm (0.01 in.)	4,000 mm (13,123.4 ft.)
	Fluorescent Vinyl	120 to 200 gf	0.25 mm (0.01 in.)	4,000 mm (13,123.4 ft.)
	Fluorescent Vinyl	100 to 200 gf	0.25 mm (0.01 in.)	4,000 mm (13,123.4 ft.)

*1 The values for "Blade life" are estimates for when an identical type of media is used.

When uncut areas remain even when the blade force is increased to a value that is higher than the values shown in this chart by 50 to 60 gf, replace the blade.

Memo

About this Manual 364
Software 365

About this Manual

This document is the user's manual for the LG-640/540/300. This document uses the following notations to distinguish between the models where necessary.

- LG-640: 64-inch model
- LG-540: 54-inch model
- LG-300: 30-inch model

Most of the figures in this document depict the LG-640.

Software

This product is equipped with an "eT-Kernel Multi-Core Edition" eT-Kernel and a "PrCONNECT(R)/Pro" TCP/IP protocol stack, both made by eSOL Co., Ltd. eT-kernel and PrCONNECT are registered trademarks of eSOL Co., Ltd.

Company names and product names are trademarks or registered trademarks of their respective holders.

