

Operation Manual

INKJET PRINTER

Tiger600-1800TS

Operation Manual

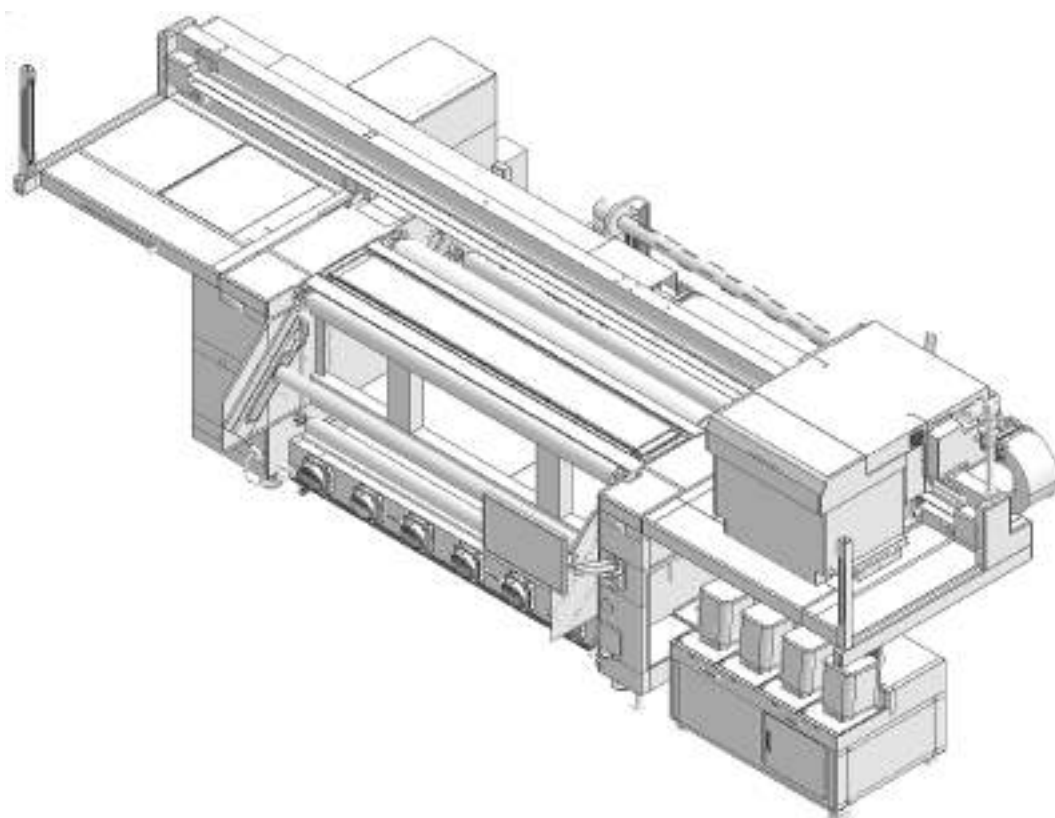

You can also download the latest manual from official website.

MIMAKI ENGINEERING CO., LTD.

<https://mimaki.com/>

D203673-11
Original instructions

TABLE OF CONTENTS

Introduction	5
To Ensure Safe Use	6
Symbols	6
Usage Precautions	7
Prohibited Dangerous Actions	11
Usage Restrictions.....	13
Usage Restrictions.....	13
Operator Restrictions.....	13
Area Restrictions	13
Connecting the Power	15
Tiger600 Wiring Configuration	15
Ink and Other Liquid Handling Precautions	19
Ink Specifications.....	20
Installation Precautions.....	21
Installation Space	22
Adjuster Feet	23
When Relocating This Machine	23
Emergency Stop Switches and Light Curtain	24
Warning labels.....	25

Chapter 1 Before Use

1.1 Items to be Prepared by the Customer.....	30
1.2 Part Names and Functions	31
Front/Rear.....	31
Ink Supply Unit.....	34
Winding unit	34
Carriage	34
Station.....	35
Platen.....	35
Light Curtain	35
Signal tower light	36
Drying unit.....	36
Maintenance Switch.....	37
1.3 System Configuration	38
Connecting to a Local Network.....	39
1.4 Preparing the RIP PC	41
RIP PC System Requirements	41
Setting up an Ethernet connection.....	41
Installing RIP Software	45
Setting Up RIP Software.....	46
1.5 Ink Tank Replacement Method.....	52
When Ink Near End is Displayed	52
When Ink End is Displayed.....	52
Replacing the Ink Tank.....	52

Chapter 2 Printing

2.1 Print Process	60
2.2 Load the media	62
Media	62
Preparation	64
Loading the Media on the Feeding Air Shaft	66
Loading the Paper Core on the Take-up Air Shaft.....	69
Loading Media on to the Printer Main Unit	71
2.3 Setting the Head Gap	77
Checking the Head Gap Value	77
2.4 Test Printing.....	78
Checking Print Head Discharge.....	78
Ejection Failures	79
2.5 Head Cleaning	80
Cleaning.....	80
Powerful Cleaning.....	80
2.6 Correcting the Drop Position.....	82
2.7 Preparing a Job (RIP Data)	83
With Output Port Set to [MIMAKISTATUSPORT].....	83
With Output Port Set to [File Interface]	89
2.8 Printing.....	93
Starting Printing	93
Stopping Printing	95
Skipping the wait until heater temperature is reached.....	95
Printing Using Nozzle Recovery	96

Chapter 3 Settings (MPC)

3.1 Mimaki Printer Controller	100
Screen structure	100
3.2 Print menu	104
3.3 Maintenance Menu	105
Registering abnormal nozzle with the nozzle check tool	106
Regist nozzle recovery	115
3.4 Setting 1 Menu.....	118
3.5 Setting 2 Menu.....	120
Function of Brake.....	120
3.6 History Menu.....	125
3.7 System menu.....	126
Power Supply.....	127

Chapter 4 Maintenance

4.1 Maintenance Precautions	130
4.2 Maintenance Timing	131
Items Required for Maintenance.....	131

4.3 Performing Maintenance.....	132
Ink Maintenance	132
Wiper Cleaning	132
Carriage Underside Cleaning	134
Wiper Unit Cleaning.....	135
Flushing Box Cleaning.....	136
Moisture Tray Cleaning.....	136
Exterior Cleaning (e.g., cover, Y-bar,)	137
Jam Sensor Detecting Plate Cleaning	138
Platen Cleaning	139
X Drive Roller Cleaning	139
Blowing Fan Filter Cleaning.....	140
Drying Unit Cleaning.....	141
Waste Ink Tank Waste Ink Level Checking	142
4.4 Consumable Item Replacement	143
Wiper Replacement	143
Carriage Filter Replacement.....	144
Blower Filter Replacement.....	145
Replace ink filter	146

Chapter 5 Troubleshooting

5.1 Troubleshooting	150
The power does not turn on.....	150
Printing is not possible.....	150
The media jams or the media is dirty.....	150
Transfer paper meandered	150
Image defects occur.	151
Ink has leaked out.....	153
Touch panel operation is not possible.	153
5.2 Problems Indicated by Messages.....	154
5.3 Collecting Logs	166

Chapter 6 Appendix

6.1 Specifications.....	170
6.2 LICENSE Library	172

Introduction

Thank you for purchasing the Inkjet printer Tiger600 series.

Read this operating manual ("this document" hereinafter) thoroughly and make sure you understand its contents to ensure safe and correct use of the product.

Please note that the illustrations contained in this manual are intended to show functions, procedures, or operations and may sometimes differ slightly from the actual machine.

Adobe, the Adobe logo, Acrobat, Illustrator, Photoshop, and PostScript are the trademarks or registered trademarks of Adobe Incorporated in the United States and other countries.

TxLink is a trademark or a registered trademark of Mimaki Engineering Co. Ltd. in Japan and other countries.

Other company and product names mentioned herein are the trademarks or registered trademarks of the respective companies in Japan and in other countries.

Unauthorized reproduction of any portion of this document is strictly prohibited.

© 2023 MIMAKI ENGINEERING Co., Ltd.

● DISCLAIMERS

- MIMAKI ENGINEERING REJECTS ALL LIABILITY FOR DAMAGE ARISING DIRECTLY OR INDIRECTLY FROM THE USE OF THE Tiger600 series ("THIS MACHINE" HEREINAFTER), WHETHER OR NOT THE PRODUCT IS FAULTY.
- MIMAKI ENGINEERING REJECTS ALL LIABILITY FOR DAMAGE, DIRECT OR INDIRECT, TO MATERIALS CREATED WHILE USING THIS MACHINE.
- USING THIS MACHINE IN CONJUNCTION WITH DEVICES OTHER THAN THOSE RECOMMENDED BY MIMAKI ENGINEERING MAY RESULT IN FIRE OR ACCIDENTS. SUCH INCIDENTS ARE NOT COVERED BY THE PRODUCT WARRANTY. MIMAKI ENGINEERING REJECTS ALL LIABILITY FOR DAMAGE, DIRECT OR INDIRECT, ARISING FROM SUCH INCIDENTS.
- USE ONLY GENUINE MIMAKI ENGINEERING INK AND MAINTENANCE LIQUID. USE OF OTHER PRODUCTS MAY RESULT IN FAILURES OR REDUCE PRINT QUALITY. SUCH INCIDENTS ARE NOT COVERED BY THE PRODUCT WARRANTY. MIMAKI ENGINEERING REJECTS ALL LIABILITY FOR DAMAGE, DIRECT OR INDIRECT, ARISING FROM SUCH INCIDENTS.
- DO NOT ATTEMPT TO REFILL THE INK TANKS WITH UNAUTHORIZED INK. SUCH INCIDENTS ARE NOT COVERED BY THE PRODUCT WARRANTY. MIMAKI ENGINEERING REJECTS ALL LIABILITY FOR DAMAGE, DIRECT OR INDIRECT, ARISING FROM SUCH INCIDENTS.

● TV and radio interference



- The machine emits high-frequency electromagnetic radiation while operating. Under certain circumstances, this may result in TV or radio interference. We make no guarantee that this machine will not affect special radio or TV equipment.
-

If radio or TV interference occurs, check the radio or TV reception after turning off the machine. If the interference disappears when the power is turned off, the machine is likely to be the cause of the interference.









Try any of the following solutions or combinations of these solutions:

- Change the orientation of the TV or radio antenna to find a position where interference does not occur.
- Move the TV or radio away from this machine.

To Ensure Safe Use

Symbols

In this manual, the symbols indicate and explain precautions. Make sure you fully understand the meaning of each symbol and use the machine safely and correctly.

Explanation		
	Warning	Indicates a potential hazard that may result in death or serious injury if handled improperly or if instructions are disregarded.
	Caution	Indicates a potential hazard that may result in minor or moderate injury if handled improperly or if instructions are disregarded.
	Notice	Indicates a potential hazard that may result in property damage if handled improperly or if instructions are disregarded.
	Warning sign	Indicates something that requires attention. Warning specifics are drawn inside the symbol.
	Mandatory action sign	Indicates an action that must be carried out. The specifics of the mandatory action are drawn inside the symbol.
	Prohibition sign	Indicates a prohibited action. The specifics of the prohibited action are drawn inside the symbol.
	Important	Indicates important information related to use of this machine.
	Tip	Indicates useful reference information.
	Reference information	Indicates the corresponding page for related information.

Usage Precautions

● In the event of abnormal conditions

WARNING



- In the event of abnormal conditions such as smoke or unusual odor, turn off the main power immediately and turn off the breaker. Continuing to use the machine under these conditions may result in failure, electric shock, or fire. Once you have confirmed that smoke is no longer being emitted, contact your local dealer or our service office. Never attempt to repair the machine yourself, which is hazardous.

CAUTION



- Immediately wipe off any ink, maintenance liquid, waste ink, or other liquid used with the product that comes into contact with your skin. Then wash using soap, and rinse with plenty of water. Failure to wash off ink may result in skin inflammation. If your skin becomes irritated or painful, seek medical attention immediately.
- If ink, maintenance liquid, waste ink, or any other liquid used in the product comes into contact with your eyes, rinse immediately with plenty of clean water. Rinse for at least 15 minutes. If you wear contact lenses and they can be easily removed, remove after rinsing for at least 15 minutes with clean water. Be sure to also rinse the undersides of your eyelids. Failure to rinse off ink may result in blindness or impaired vision. If your eyes become irritated or painful, seek medical attention immediately.
- If ink, maintenance liquid, waste ink, or any other liquid used in the product enters your mouth or is swallowed, gargle with water immediately. Do not induce vomiting. Seek medical attention promptly. Inducing vomiting may cause liquid to enter the airway.
- If a large amount of vapor is inhaled, move to a well-ventilated area, keep warm, and rest in a posture that allows easy breathing. If the condition does not improve, seek medical attention promptly.

NOTICE



- If an ink leak occurs, turn off the main power immediately and turn off the breaker. Then, contact your local dealer or our service office.

● Power supply precautions

⚠ WARNING



- Do not damage or modify the power cable. Do not place heavy objects on, heat or stretch it. Doing so may damage the cable, leading to electric shock or fire.
- Do not use the power cable if it is damaged or broken or if the core wire is exposed. Otherwise there is a risk of failure, electric shock, or fire.



- Always connect the machine to a switchboard with grounded polarity. Otherwise there is a risk of failure, electric shock, or fire. All electrical work (Class C grounding work; formerly Type 3 grounding work) must be handled by a licensed electrician.

NOTICE



- Do not turn off the main power supply for the machine and the power supply for the control PC. Turning off the power supply will disable the automatic maintenance function (including nozzle clogging prevention function and ink discharge channel cleaning function). This increases the risk of ejection failures (such as nozzle clogging or deflection).



- Use the machine with a power supply that meets specifications.
- When connecting the power cable, check the input voltage of the power outlet and the capacity of the breaker. Also, connect each cable to a separate power source with an independent breaker. Connecting to power outlets linked with the same breaker will cause the breaker to trip.

● Vacuum unit

NOTICE



- Do not disassemble or modify the vacuum unit. Doing so may decrease the vacuum strength or cause the machine to become hot, leading to a failure.



- Do not touch the relief valve (pressure regulating valve) or block the vacuum unit exhaust port. Doing so may decrease the vacuum strength or cause the machine to become hot, leading to a failure.





- When used in a low-temperature environment, the vacuum unit may generate a high-pitched noise. The high-pitched sound does not indicate a failure.

● Do not stand or sit on the machine.

NOTICE



- Never stand or sit on the platen. Disregarding this precaution may impair the precision of the platen surface and affect print quality.
- Never stand or sit on the drying unit, take-up/feeding motors, or external supply unit. Disregarding this precaution is extremely dangerous and may damage the machine and result in injury.

● Caution regarding moving parts

⚠ CAUTION



- Keep parts of the body such as the face and hands away from moving parts. Also keep clothing (e.g., loose clothing and accessories) that may impede work away from the machine. Failure to do so may result in injury.



- Long hair should be tied back. Failure to do so may result in injury.

● Do not disassemble or repair

⚠ WARNING



- Do not attempt to disassemble or repair this machine. Otherwise there is a risk of failure, electric shock, or fire.

● About the monitor arm

⚠ CAUTION



- The maximum load capacity of the monitor arm is 8 kg. Do not install a monitor that is heavier than the maximum load capacity. Doing so may damage the arm.
- The monitor arm on which the touch panel is mounted is attached to the front of the machine. Take care to avoid bumping into the monitor arm or touch panel and injuring yourself while working.

NOTICE



- The monitor arm angle can be adjusted to vary the touch panel mounting angle and orientation. Adjust the arm angle so as not to impede the carriage movement range or printing operations.

● About the touch panel

NOTICE



- Do not press, rub, or push the touch panel with excessive force.
- Do not tap the touch panel with a ball-point pen or other hard metal object.
- Do not touch the black outer frame of the screen.
- Do not affix adhesive tape or labels to the touch panel screen or black outer frame. Doing so may reduce sensitivity and prevent operation.

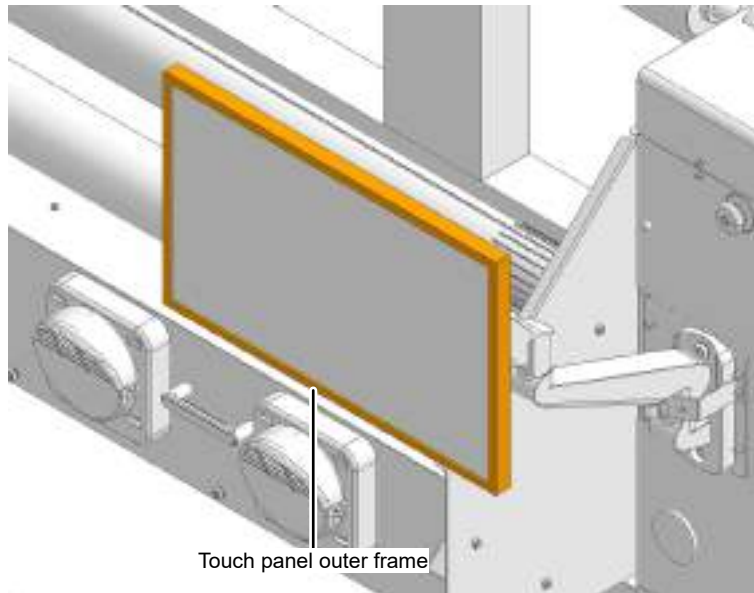

- Immediately wipe off any liquid on the touch panel.
- Take care not to allow any liquids to get inside the touch panel gaps.

● Other usage precautions

WARNING



- Keep children away from the machine.

CAUTION



- Do not use the product after consuming medication or alcohol that may impair movement or thinking. Otherwise there is a risk of injury due to incorrect operation.

NOTICE

● Disposing of the product

CAUTION



- Please contact your local retailer or service agent.
- When disposing of the product yourself, contact an industrial waste disposal operator or dispose of the product in accordance with local laws and regulations.

Prohibited Dangerous Actions

Never perform any of the following dangerous actions while the power is turned on. Disregarding these precautions may result in serious injury (crushing or severing) if the carriage moves, for example during periodic maintenance.

● Keep face, hands, and body away from carriage



- Keep your face, hands, and body away from the gap between the carriage and Y-bar.



- Keep your face, hands, and body away from the gaps between the carriage and platen or station.



● Keep face, hands, and body away from moving parts



- Keep your face, hands, and body away from the Y-bar belt.



● **Keep face, hands, body, and other objects away from cableveyor**



- Keep your face, hands, and body away from the Y cableveyor, and do not place objects on top of it.



● **Keep face, hands, and body away from underneath platen during operation**



- Do not crawl under or insert your face, hands, or body underneath the platen while the machine is operating.

● **Keep face, hands, and body away from take-up unit, and do not peer inside during operation**



- Keep your face, hands, and body away from the take-up unit, and do not peer inside while the machine is operating.

● **Keep hands and objects away from platen**



- Keep your face, hands, and body away from the platen, and do not place objects other than media on top of it.



● **Do not impede carriage operation**



- Do not forcibly move the carriage while it is operating (e.g. during printing and cleaning).

Usage Restrictions

Usage Restrictions

⚠ WARNING



- The machine includes fast-moving and high temperature parts, which present extreme hazards. The machine must be used only by persons that are fully aware of these potential dangers.

Operator Restrictions

⚠ WARNING



- The machine must be operated only by persons that have received our safety training or who have been trained by such trained personnel.

Area Restrictions

⚠ WARNING



- Persons other than users who have received the appropriate training are prohibited from approaching the machine. Restrictions must be applied to the area indicated in the diagram below. The area restrictions must make it clear that the area is hazardous, for example by installing the machine within a dedicated room or by enclosing it within a fence.
- Implement measures to prevent those other than persons that have received our safety training or who have been trained by such trained personnel from entering the danger area. There is a danger of injury from moving parts such as the carriage or tension bar while printing is in progress if untrained personnel are allowed within the restricted area while the machine is operating.

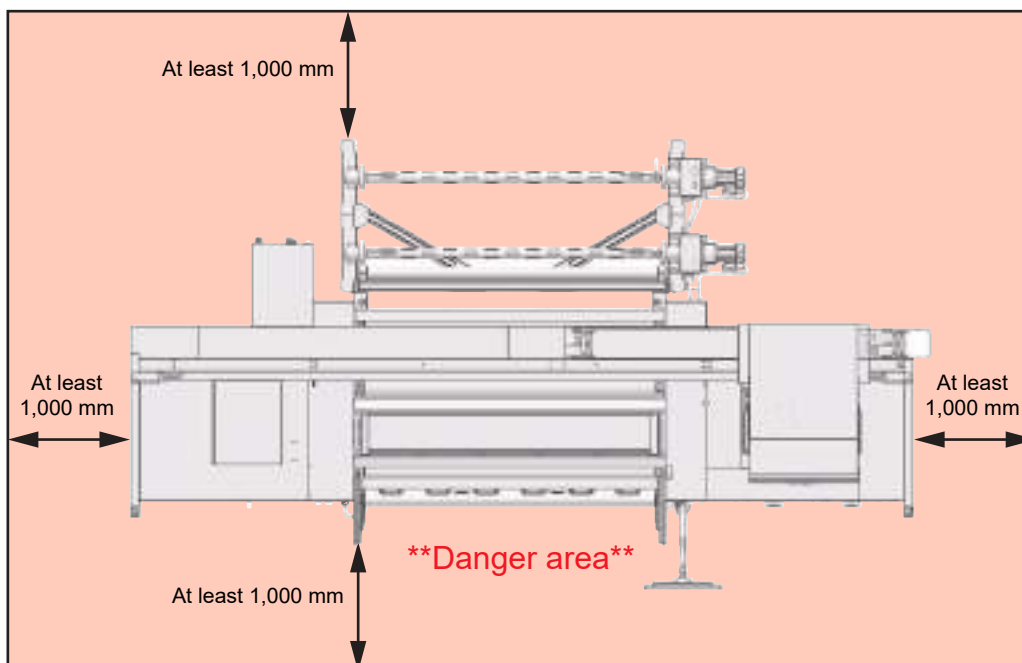



- If a safety fence is used to restrict the area, this should comply with the EN ISO 13857 standard.
 - If the machine is installed in a dedicated room, locks and safety Interlocks should be provided on the doors to the room, and ultimately a risk assessment should be conducted for the installation before use.
-

Connecting the Power

The printer requires a large power supply and must be powered directly from the switchboard. Customers must complete any electrical work before the printer is carried in.



- Always connect the machine to a switchboard with grounded polarity. Otherwise there is a risk of failure, electric shock, or fire. All electrical work (Class C grounding work; formerly Type 3 grounding work) must be handled by a licensed electrician.



- Make sure the connections are correct. Incorrect connections may result in damage to the equipment.
- Be careful to avoid problems in wiring configuration.

Tiger600 Wiring Configuration



- Terminal blocks are attached inside the machine's electrical box. A power cable is not included. The user is responsible for providing power cables. Electrical work between the terminal blocks connecting the switchboard to the main unit must be performed by a licensed electrician.
- Be sure to only use the following types of cables and circuit breakers.
 - (1) Cable: VCT-5.5 mm² × 5-core (600 V) or UL-AWG10 × 5C (600 V) or equivalent. Outer sheath external diameter 16 to 25 mm.
 - (2) Circuit breaker: Three-phase four-wire 380 to 415 V AC, 30 A

● Wiring connections



- Check the specifications of the switchboard three-phase power supply. A delta-star conversion transformer must be provided if three-phase four-wire star connection wiring is not used.

If the power supply is three-phase Y (star) connected (three wires + neutral)

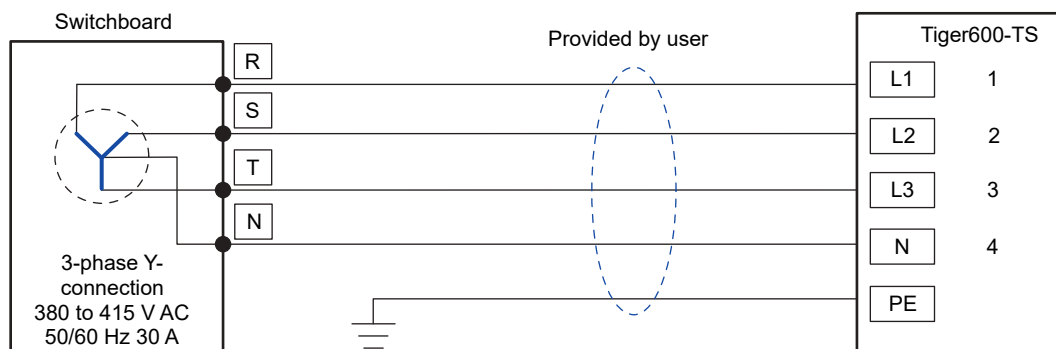

If the power supply is three-phase Δ (delta) connected (three wires)

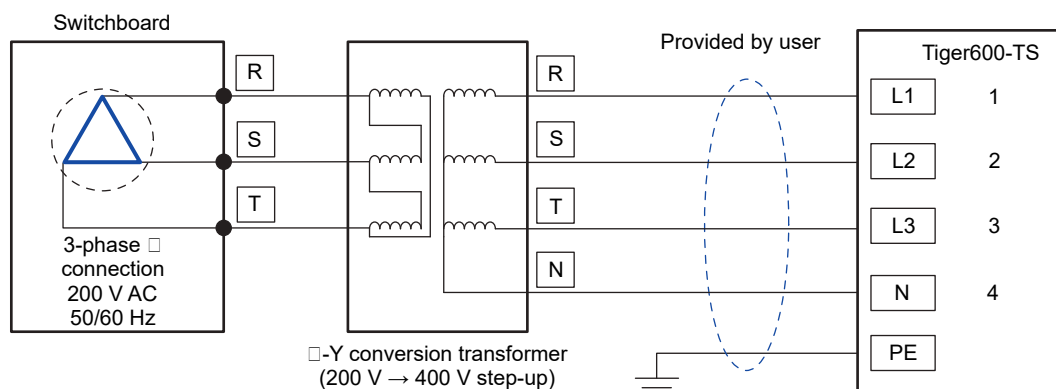

● Wire preparation

1 Strip the power cable sheath as shown in the diagram below.

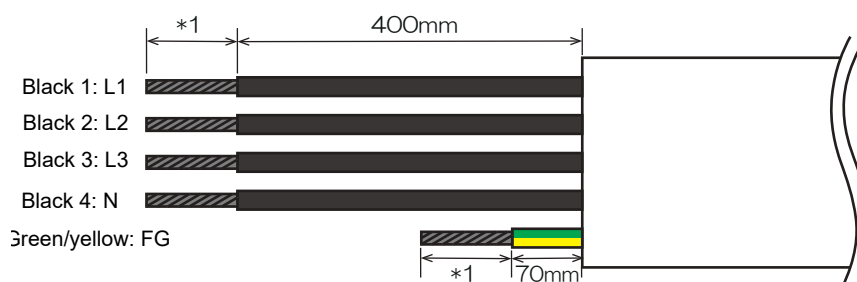

Please prepare the wire according to the particular crimp terminal specifications.

2 Attach the allowable types of crimp terminals to the L1, L2, L3, N, and FG wires.

- The sheath must be stripped off the wires to a length that is appropriate for the crimp terminal type you are using.
- For more information regarding allowable crimp terminals, see below.

- Terminal block connection details

(1) Model No.: TXUM3004

(2) Manufacturer: Patlite

(3) Terminal screws: M5 × 10

- L1, L2, L3, and N wire end preparation

(1) Preparation method: Ring terminal with insulating layer

(2) Shape:

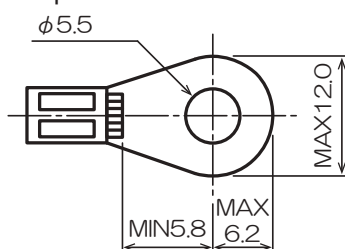

(3) Examples of allowable crimp terminals:

- N5.5-5 (J.S.T. Mfg)
- FN5.5-5 (J.S.T. Mfg)
- TMEX5.5-5 (Nichifu)

- FG wire end preparation

(1) Preparation method: Ring terminal with insulating layer

(2) Mounting screws: M5 × 10 (3-part SEMS screw)

(3) Examples of allowable crimp terminals:

- N5.5-5 (J.S.T. Mfg)
- FN5.5-5 (J.S.T. Mfg)
- TMEX5.5-5 (Nichifu)

- Screw tightening torque: 2.2 to 2.8 Nm



- Be sure to observe the following three points. Failure to observe the following three points may result in fire, smoke generation, or electric shock.
 - (1) Only use power cables and crimp terminals that satisfy the specifications.
 - (2) Be sure to attach a ring crimp terminal to the end of the power cable.
 - (3) Secure the ring terminal to the terminal block using the specified tightening torque.

● Power connection work

- 1** Make sure that the machine main power supply and the switchboard circuit breaker have been turned off.
- 2** Remove the lower cover on the power supply box.
- 3** Loosen the nut on the cable gland, and insert the cable.
 - If the power cable has an outer diameter of 20 mm or less, use the FGA33-22B provided instead.

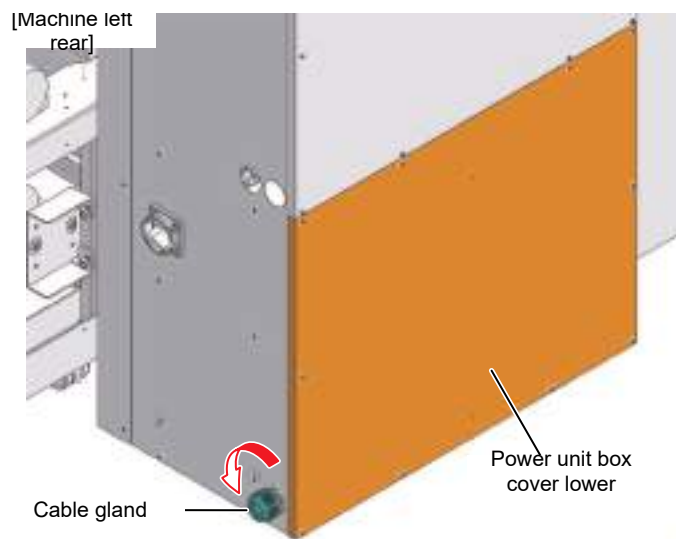

- 4** Secure the L1, L2, L3, and N wires to the terminal block, and secure the FG wire to the screw hole next to the protective ground name plate.
- Tighten the terminal block screws to a torque of 2.2 to 2.8 Nm.

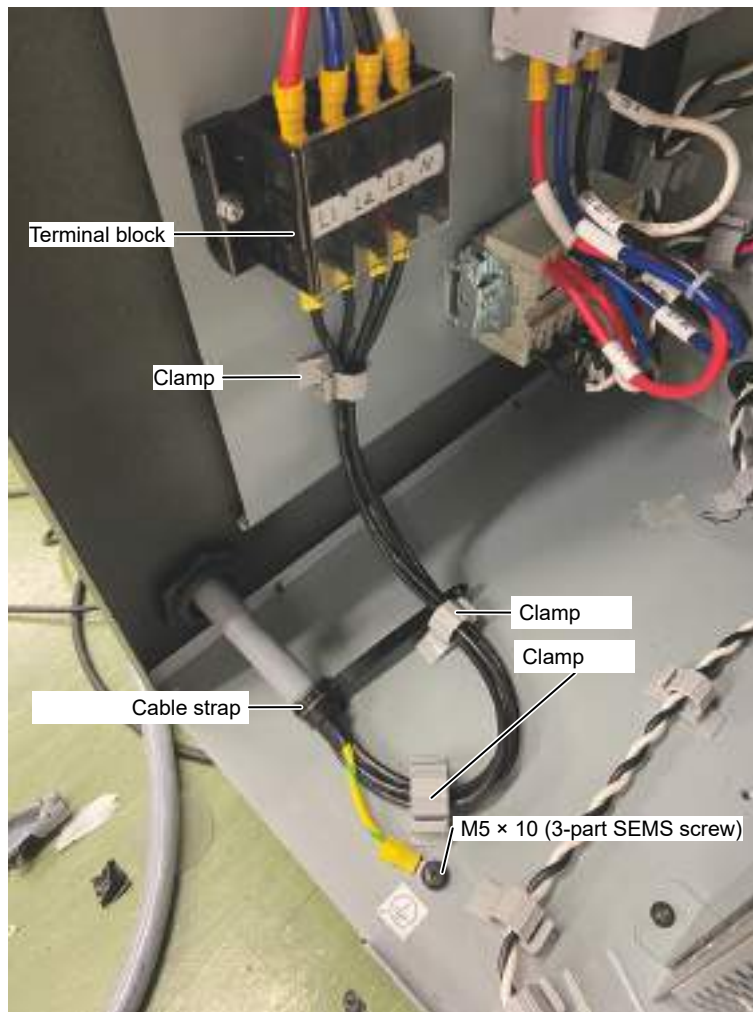

- 5** Once the cable has been wired in place, secure using the clamps and cable strap.
- 6** Tighten the nut on the cable gland, and replace the lower cover on the power supply box.

Ink and Other Liquid Handling Precautions

Precautions regarding liquids are indicated on the containers of ink, maintenance liquid, and other liquids used with this machine. Thoroughly read them and make sure you understand the contents.



- Be sure to read the safety data sheet (SDS) before use. <https://mimaki.com/supply/sds/>

CAUTION



- Pay close attention to ventilation and be sure to wear safety glasses, gloves, and a mask when handling ink, maintenance liquid, waste ink, or other solutions used with the machine. Leaking ink may adhere to the skin or get into the eyes or mouth.



- Do not subject cases containing ink to strong shock or violent shaking. Do not attempt to refill the ink. Leaking ink may adhere to the skin or get into your eyes or mouth.



- Do not disassemble cases containing ink. Leaking ink may adhere to the skin or get into your eyes or mouth.



- Keep ink, maintenance liquid, and other liquids used with the machine out of the reach of children.



- When disposing of liquids used with the machine (such as ink or maintenance liquid) or containers, paper towels, or the like with this residue on them, contact an industrial waste disposal operator or dispose of in accordance with local laws and regulations.

NOTICE



- Do not store ink, maintenance liquid, or other liquids used with the machine in locations exposed to direct sunlight.
- Do not store ink, maintenance liquid, or other liquids used with the machine in locations filled with metalworking fluids or highly volatile substances (e.g., amines and amine-modified alcohols). Storing in locations like this will increase the risk of failure or ejection failures (e.g., nozzle clogging and deflection).
- Do not use ink, maintenance liquid, or other liquids used with this machine with other printers. Disregarding this precaution may cause the machine to fail.



- Store in a location not more than 1 m above the floor. There is a risk of liquid splashing if the tank falls.
- Store the tank in a sealed condition.
- Store the tank in a cool, dark location.
 - (1) Store in conditions where the ink will not freeze. Using ink that has frozen and then thawed may result in reduced print quality due to degradation of the ink constituents.
 - (2) When using ink that has been moved from a cold location to a warm location, allow it to stand for at least 3 hours in the same conditions as the printer, and check that the temperature is the same as that of the operating environment before using it.
 - (3) Open the ink immediately before use, and use it up as quickly as possible. The print quality may be reduced when using ink a long time after it was opened.



- Do not use ink, maintenance liquid, or other liquids used with this machine with other printers. Disregarding this precaution may cause the machine to fail.

Ink Specifications

Item		Details
Type		MLSb510
Color		Yellow (Y) Magenta (M) Blue (B) Black (K)
Form		Ink tank or pack-in-box
Ink capacity		10L
Expiration date		As indicated on the Ink tank. However, ink should be consumed within three months after opening, even if before the expiration date.
Storage temperature	When stored	5 °C to 30 °C (daily mean temperature) However, not more than 1 month at 30 °C <ul style="list-style-type: none"> Ink quality may deteriorate if stored outside these conditions.
	During transportation	1 °C to 60 °C However, not more than 120 hours at 60 °C, and not more than 1 month at 40 °C <ul style="list-style-type: none"> Where possible, avoid storing in cold locations below 0 °C and hot locations above 40 °C. Ink quality may deteriorate if stored outside these conditions.



- The ink expiration date is indicated on the ink containers. Expired ink may cause ejection failures or alter the color tone. Printing is possible even if the ink has passed its expiration date. Nevertheless, we recommend replacing with new ink or using up as quickly as possible.

Installation Precautions

WARNING



- Do not install the machine in locations where naked flames are used.
- Do not place plant pots, cups, containers of cosmetics, chemicals, or water, or small metal objects on top of the machine. There is a risk of failure, electric shock, or fire if liquids or other items fall inside the machine.



- Do not install this machine in humid locations or locations where it may be exposed to splashing water. Otherwise there is a risk of failure, electric shock, or fire.



- Do not install the machine where children may enter.

CAUTION



- A ventilation system must be provided if this machine is installed in a poorly ventilated area or sealed room.
- Be sure to observe the following points when installing an extractor outlet:
 - (1) The extractor outlet must be installed in accordance with applicable local EHS (environmental, health, and safety) guidelines.
 - (2) If the extractor outlet is fitted with a shutoff valve, the valve must be open when this machine is in use.



- Check to confirm that the floor is sufficiently strong to bear the weight of the machine before installing.

NOTICE



- Do not install this machine in locations where dust or powder is present. Failure or printing defects may result (e.g., nozzle clogging, deflection) if dust gets inside this machine.
- Do not install this machine in locations exposed to drafts (e.g., from air conditioning). Disregarding this precaution may result in dust or powder getting inside this machine.
- Do not install this machine in unstable locations or locations subject to vibration. This will increase the risk of failure or printing defects (e.g., nozzle clogging, deflection).
- Do not install this machine in locations exposed to direct sunlight.
- Do not install this machine in locations subject to sudden temperature changes. This will increase the risk of failure or printing defects (e.g., nozzle clogging, deflection).
- Do not install this machine in locations exposed to excessive noise from large machinery.
- Do not install this machine in locations where photographic fixing agents generate vapor or acid gas (e.g., acetic acid, hydrochloric acid) or locations filled with metal working fluids or highly volatile substances (e.g., amines, amine-modified alcohols). Malfunctions or printing defects may result (e.g., nozzle clogging, deflection) as print head ink is more likely to harden under such environments.



- Operating environment: 20 °C to 30 °C (68 °F to 86 °F), 35 %RH to 65 %RH (no condensation)
- Temperature range in which accuracy is guaranteed: 20 °C to 25 °C (68 °F to 77 °F)



- Install the machine in a location where the entire working area is clearly visible. (Guideline: 300 lux)
There is a risk of incorrect operation and injury if operated in a dark location.

Installation Space

Provide the following space around the machine to allow safe and proper replacement of ink and media:

Item	Tiger600-1800TS
Width ^{*1}	At least 8,300 mm (5,300 mm)
Depth ^{*1}	At least 5,800 mm (2,800 mm)
Height ^{*1}	(1,900 mm)
Weight	1,620 kg

*1. The figures in parentheses indicate machine dimensions.

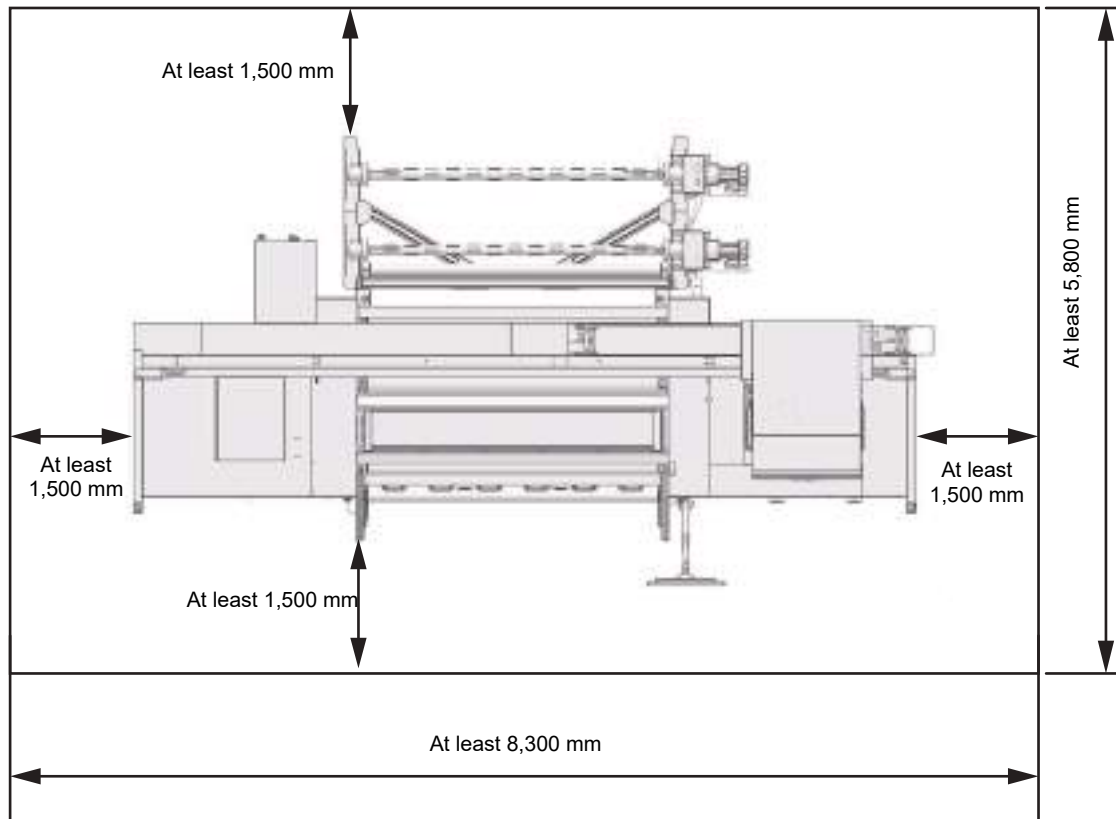

- If a safety fence is used to restrict the area, this should comply with the EN ISO 13857 standard.
- If the machine is installed in a dedicated room, locks and safety Interlocks should be provided on the doors to the room, and ultimately a risk assessment should be conducted for the installation before use.

Adjuster Feet

Do not attempt to adjust the adjuster feet yourself. Doing so may prevent the machine from operating correctly.

If you have any queries, contact your local distributor, our sales office, or service center.

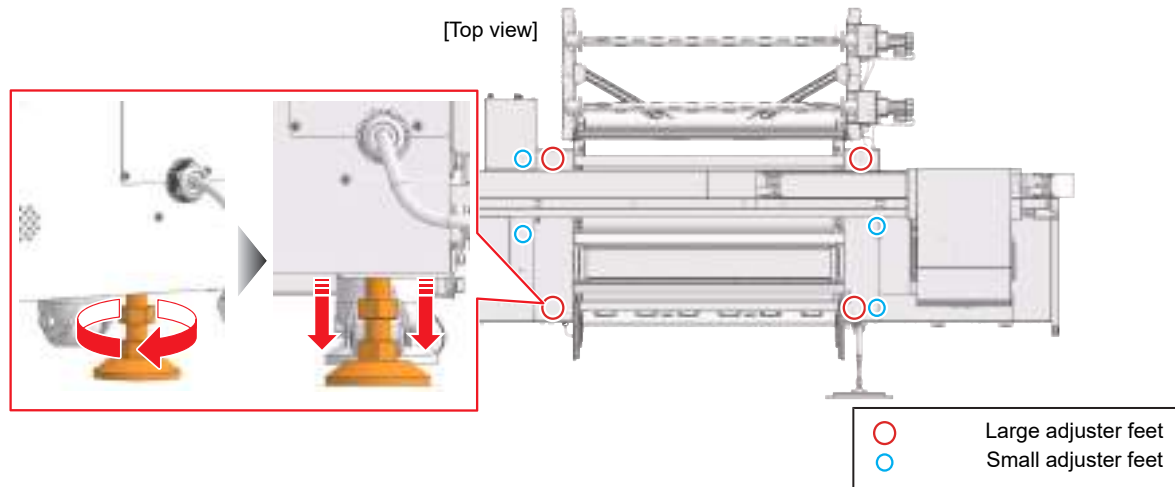

When Relocating This Machine

Contact your local dealer or our service office. Attempting to handle relocation yourself may result in failure or damage.

Emergency Stop Switches and Light Curtain

The machine is equipped with emergency stop switches and a light curtain to ensure safety during use. The light curtain stops the machine when a person or object is detected.



- Check to confirm that the emergency stop switches and light curtain operate correctly before starting operation.



- If an obstruction or danger to the operator occurs, press one of the emergency stop switches to stop the machine and prevent more serious problems from arising.



- To release an emergency stop switch, check to confirm that there are no objects trapped in the feed unit and that the operator is safe before resetting the switch. To reset the emergency stop switch, turn it counterclockwise. Once the emergency stop switch has been reset and the alarm has been cleared on the MPC screen, the feed unit initializes, after which the machine is ready for operation.

● Emergency stop switch locations and light curtain detection area

[Front]

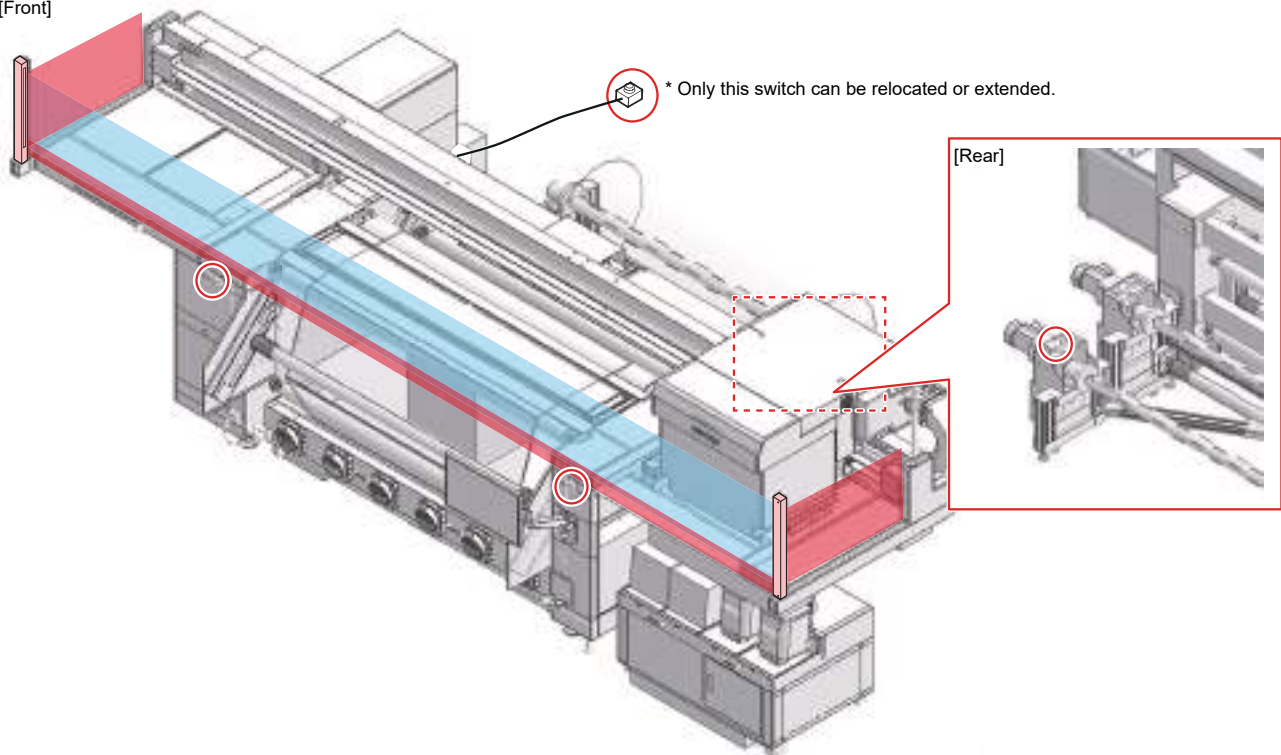









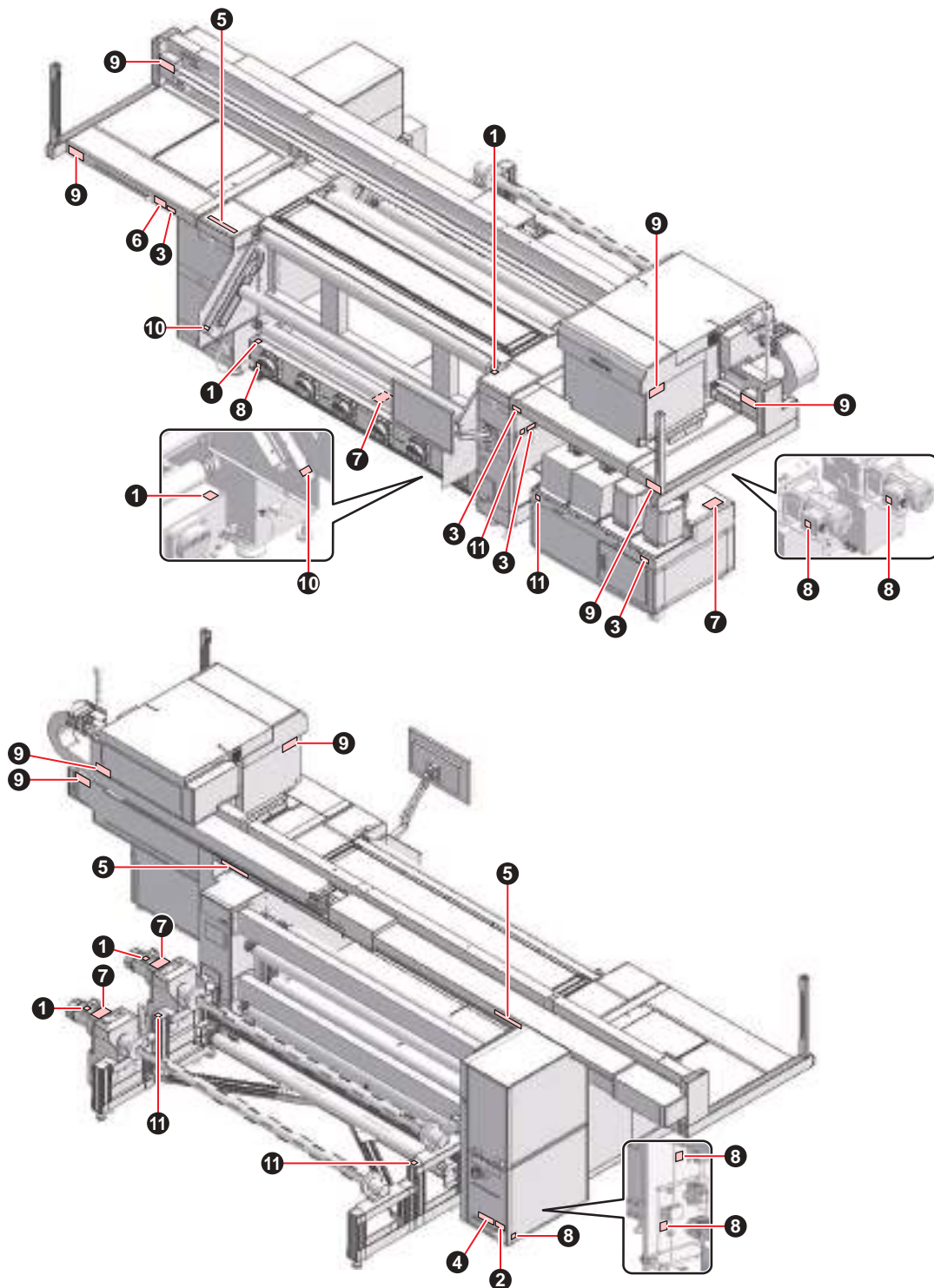







- : Light curtain detection area
- : Area not detected by light curtain (area 61.5 mm above the platen and also the sides)
- : Emergency stop switch



Warning labels

Make sure you fully understand the details indicated on the various warning labels.

If any of the warning labels becomes dirty and illegible or peel off, contact your local dealer or our service office to request new warning labels.



N o.	Order code	Label	Details						
1	M903239		Indicates hot parts.						
2	M903281	<p>See SET UP GUIDE before connecting to the supply.</p> <p>電源を接続する前に、必ず セットアップガイドを読むこと。 在接通电源之前请一定阅读安装说明书。</p>	Note when connecting the power supply cable.						
3	M903330		Wear safety glasses and gloves while working.						
4	M905624	<table border="1" data-bbox="440 680 968 810"> <tr> <td data-bbox="440 680 703 741"> <p>⚠ 警告</p> <p>漏えい電流大 電源へ接続する前に 接地接続が必要</p> </td> <td data-bbox="703 680 968 741"> <p>⚠ WARNING</p> <p>HIGH LEAKAGE CURRENT EARTH CONNECTION ESSENTIAL BEFORE CONNECTING SUPPLY</p> </td> </tr> <tr> <td data-bbox="440 741 703 810"> <p>⚠ AVERTISSEMENT</p> <p>COURANT DE FUITE ELEVE CONNECTER LA MISE A LA TERRE AVANT DE CONNECTER L'ALIMENTATION</p> </td> <td data-bbox="703 741 968 810"> <p>⚠ WARNUNG</p> <p>HOHER KRIECHSTROM BITTE ERDKABEL ANSCHLIESSEN BEVOR SIE STROMZUFUHR ANSCHLIESSEN</p> </td> </tr> </table>	<p>⚠ 警告</p> <p>漏えい電流大 電源へ接続する前に 接地接続が必要</p>	<p>⚠ WARNING</p> <p>HIGH LEAKAGE CURRENT EARTH CONNECTION ESSENTIAL BEFORE CONNECTING SUPPLY</p>	<p>⚠ AVERTISSEMENT</p> <p>COURANT DE FUITE ELEVE CONNECTER LA MISE A LA TERRE AVANT DE CONNECTER L'ALIMENTATION</p>	<p>⚠ WARNUNG</p> <p>HOHER KRIECHSTROM BITTE ERDKABEL ANSCHLIESSEN BEVOR SIE STROMZUFUHR ANSCHLIESSEN</p>	Caution regarding current leakage.		
<p>⚠ 警告</p> <p>漏えい電流大 電源へ接続する前に 接地接続が必要</p>	<p>⚠ WARNING</p> <p>HIGH LEAKAGE CURRENT EARTH CONNECTION ESSENTIAL BEFORE CONNECTING SUPPLY</p>								
<p>⚠ AVERTISSEMENT</p> <p>COURANT DE FUITE ELEVE CONNECTER LA MISE A LA TERRE AVANT DE CONNECTER L'ALIMENTATION</p>	<p>⚠ WARNUNG</p> <p>HOHER KRIECHSTROM BITTE ERDKABEL ANSCHLIESSEN BEVOR SIE STROMZUFUHR ANSCHLIESSEN</p>								
5	M906115	<table border="1" data-bbox="424 842 981 909"> <tr> <td data-bbox="424 842 544 909">  <p>⚠ 警告</p> <p>手指和身体请勿靠近运 转部位，以免造成危险</p> </td> <td data-bbox="544 842 632 909"> <p>⚠ 警告</p> <p>危険な可動部 指や体を近づけないように</p> </td> <td data-bbox="632 842 719 909"> <p>⚠ WARNING</p> <p>HAZARDOUS MOVING PARTS Keep fingers and other body parts away.</p> </td> <td data-bbox="719 842 807 909"> <p>⚠ WAARSCHUWING</p> <p>GEFAHRLICHE BEWEGLICHE TEILE Finger und andere Körperteile fernhalten.</p> </td> <td data-bbox="807 842 981 909"> <p>⚠ AVERTISSEMENT</p> <p>PIECES MOBILES DANGEREUSES Doigts et autres parties du corps sont hors de portée.</p> </td> </tr> </table>	 <p>⚠ 警告</p> <p>手指和身体请勿靠近运 转部位，以免造成危险</p>	<p>⚠ 警告</p> <p>危険な可動部 指や体を近づけないように</p>	<p>⚠ WARNING</p> <p>HAZARDOUS MOVING PARTS Keep fingers and other body parts away.</p>	<p>⚠ WAARSCHUWING</p> <p>GEFAHRLICHE BEWEGLICHE TEILE Finger und andere Körperteile fernhalten.</p>	<p>⚠ AVERTISSEMENT</p> <p>PIECES MOBILES DANGEREUSES Doigts et autres parties du corps sont hors de portée.</p>	Caution regarding moving parts.	
 <p>⚠ 警告</p> <p>手指和身体请勿靠近运 转部位，以免造成危险</p>	<p>⚠ 警告</p> <p>危険な可動部 指や体を近づけないように</p>	<p>⚠ WARNING</p> <p>HAZARDOUS MOVING PARTS Keep fingers and other body parts away.</p>	<p>⚠ WAARSCHUWING</p> <p>GEFAHRLICHE BEWEGLICHE TEILE Finger und andere Körperteile fernhalten.</p>	<p>⚠ AVERTISSEMENT</p> <p>PIECES MOBILES DANGEREUSES Doigts et autres parties du corps sont hors de portée.</p>					
6	M906222		Caution overhead.						
7	M907764	<table border="1" data-bbox="560 1128 847 1581"> <tr> <td data-bbox="560 1128 847 1245"> <p>注意</p> <p>⚠ CAUTION ATTENTION</p> </td> </tr> <tr> <td data-bbox="560 1245 847 1451">  </td> </tr> <tr> <td data-bbox="560 1451 847 1581"> <p>上部に乗るな DO NOT STEP ON TOP NE GRIMPEZ PAS DESSUS</p> </td> </tr> </table>	<p>注意</p> <p>⚠ CAUTION ATTENTION</p>		<p>上部に乗るな DO NOT STEP ON TOP NE GRIMPEZ PAS DESSUS</p>	Do not climb on top			
<p>注意</p> <p>⚠ CAUTION ATTENTION</p>									
									
<p>上部に乗るな DO NOT STEP ON TOP NE GRIMPEZ PAS DESSUS</p>									
8	M907935		Caution regarding high voltage.						
9	M909381	<table border="1" data-bbox="424 1749 981 1995"> <tr> <td data-bbox="424 1749 568 1872">  </td> <td data-bbox="568 1749 775 1872"> <p>⚠ 警告</p> <p>危険な可動部/指や体を 近づけないように。</p> </td> <td data-bbox="775 1749 981 1872"> <p>⚠ WARNING</p> <p>-HAZARDOUS MOVING PARTS- Keep fingers and other body parts away.</p> </td> </tr> <tr> <td data-bbox="424 1872 568 1995">  </td> <td data-bbox="568 1872 775 1995"> <p>⚠ WARNUNG</p> <p>-GEFAHRLICHE BEWEGLICHE TEILE- Finger und andere Körperteile fernhalten.</p> </td> <td data-bbox="775 1872 981 1995"> <p>⚠ AVERTISSEMENT</p> <p>-PIECES MOBILES DANGEREUSES- Doigts et autres parties du corps sont hors de portée.</p> </td> </tr> </table>		<p>⚠ 警告</p> <p>危険な可動部/指や体を 近づけないように。</p>	<p>⚠ WARNING</p> <p>-HAZARDOUS MOVING PARTS- Keep fingers and other body parts away.</p>		<p>⚠ WARNUNG</p> <p>-GEFAHRLICHE BEWEGLICHE TEILE- Finger und andere Körperteile fernhalten.</p>	<p>⚠ AVERTISSEMENT</p> <p>-PIECES MOBILES DANGEREUSES- Doigts et autres parties du corps sont hors de portée.</p>	Caution regarding moving parts.
	<p>⚠ 警告</p> <p>危険な可動部/指や体を 近づけないように。</p>	<p>⚠ WARNING</p> <p>-HAZARDOUS MOVING PARTS- Keep fingers and other body parts away.</p>							
	<p>⚠ WARNUNG</p> <p>-GEFAHRLICHE BEWEGLICHE TEILE- Finger und andere Körperteile fernhalten.</p>	<p>⚠ AVERTISSEMENT</p> <p>-PIECES MOBILES DANGEREUSES- Doigts et autres parties du corps sont hors de portée.</p>							

N o.	Order code	Label	Details
1 0	M912054		Caution regarding entrapment.
1 1	M918531		Caution when lifting heavy objects.

Chapter 1 Before Use



This chapter

This chapter describes information essential before use, such as part names.

Items to be Prepared by the Customer	30	System Configuration	38
Part Names and Functions	31	Connecting to a Local Network	39
Front/Rear	31	Preparing the RIP PC	41
Ink Supply Unit	34	RIP PC System Requirements	41
Winding unit	34	Setting up an Ethernet connection	41
Carriage	34	Installing RIP Software	45
Station	35	Setting Up RIP Software	46
Platen	35	Ink Tank Replacement Method	52
Light Curtain	35	When Ink Near End is Displayed	52
Signal tower light	36	When Ink End is Displayed	52
Drying unit	36	Replacing the Ink Tank	52
Maintenance Switch	37		

1.1 Items to be Prepared by the Customer

The following items should be prepared by the customer before installing the machine.

● Equipment and consumable items

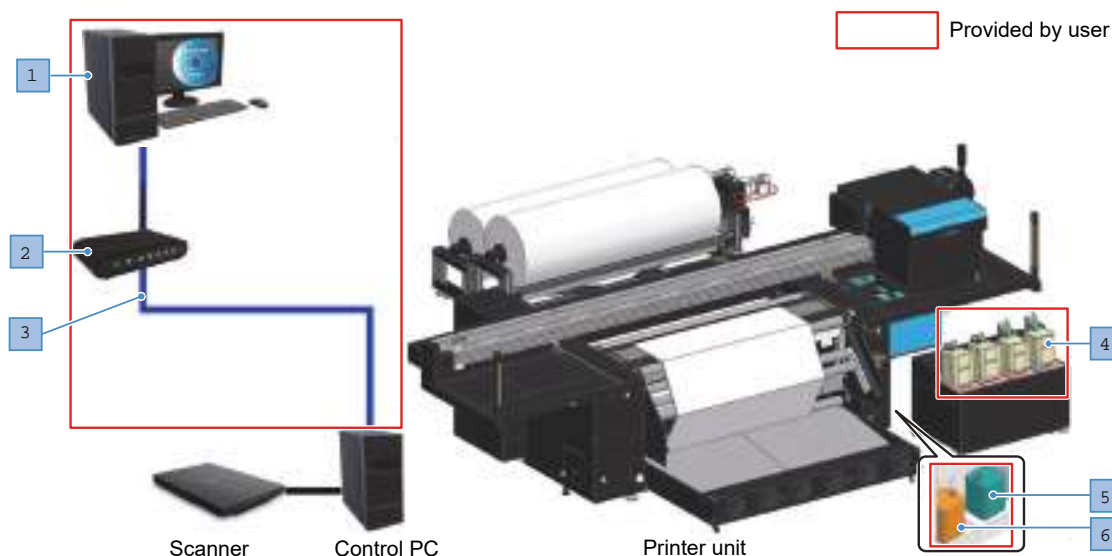

No.	Item	Remarks
1	RIP PC	Reference: "Recommended RIP PC requirements"(P. 41)
2	10 Gb compatible hub	When using multiple machines with the same PC
3	LAN cable	As required
4	Ink	10 L ink tanks for water-based sublimation ink
5	Purified water	-
6	Purified water tank	Max. 220 mm (W) × 350 mm (D) × 400 mm (H)
7	Waste ink tank	

● Installation environment and equipment

Item	Requirements	Remarks
Main unit power supply	3ø-4L-380 to 415 V AC, 25 A	
Power supply circuit breaker	"Connecting the Power"(P. 15)	
Power cable		Use the cable gland provided (FGA33-22B) for cables with an outer diameter of 20 mm or less.
Transformer		
Air facilities	Compressor capacity: 6 to 8 bar@Dry air	For air chuck shaft
Lifter	"Lifter specifications"(P. 63)	For loading the media

For more information on other installation environment requirements, refer to "Specifications"(P. 170).

1.2 Part Names and Functions

Front/Rear

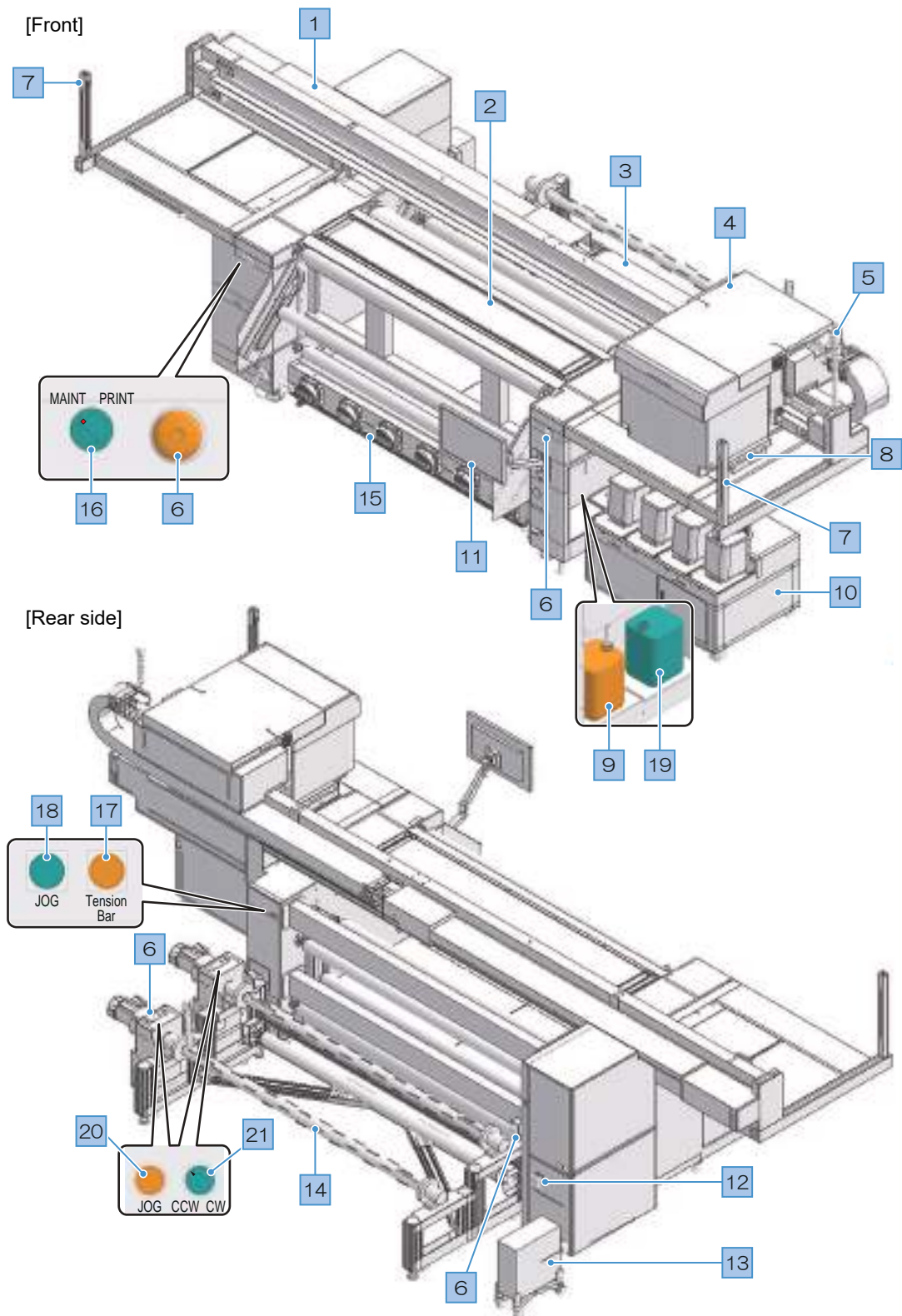

No.	Name	Overview
1	Y-bar	The Y-bar is equipped with a carriage. This part moves over the table to print.
2	Platen	Print area. "Platen"(P. 35)
3	Cable carrier (Y-bar)	Ink tubes and other parts are routed through the cable carrier. Do not insert your hands or other objects into the cable carrier.
4	Carriage	Consists of components such as the print head and jam sensor. "Carriage"(P. 34)
5	Signal tower light	To confirm machine status, check the color of the illuminated lights. A buzzer sounds to signal that the carriage will begin moving soon. "Signal tower light"(P. 36)
6	Emergency stop switch	Press to stop the machine in emergencies. Located on the left and right sides on both the front and rear. "Emergency Stop Switches and Light Curtain"(P. 24)
7	Light Curtain	Detection of a person or object will halt the machine. "Light Curtain"(P. 35)
8	Station	Includes wipers and a moisture tray to prevent the print head nozzle surface from drying out. "Station"(P. 35)
9	Waste ink tank	<ul style="list-style-type: none"> • Container for waste ink. "Waste Ink Tank Waste Ink Level Checking"(P. 142) • This should be provided by the customer. "Items to be Prepared by the Customer"(P. 30)
10	Ink Supply Unit	Supplies ink to the print head from the Ink tank. "Ink Supply Unit"(P. 34)
11	Touch panel	<p>The touch panel is used to control the machine. "Mimaki Printer Controller"(P. 100)</p> <ul style="list-style-type: none"> • How to operate the touch panel <ul style="list-style-type: none"> – Tap: Select a function. – Long tap: Select multiple jobs. – Swipe: Move the screen up or down.
12	Main power switch	Main power supply for the machine. To prevent print head ejection failures (such as nozzle clogging or deflection), do not turn off the main power supply. "Power Supply"(P. 127)
13	Control PC	Controls the machine. Do not turn off the control PC. "System Configuration"(P. 38)
14	Winding unit	Consists of the take-up unit and feeding unit. "Winding unit"(P. 34)
15	Drying unit	Dries the ink on the printed media from underneath the machine. "Drying unit"(P. 36)
16	Maintenance Switch	Selects maintenance mode (MAINT) or print mode (PRINT). "Maintenance Switch"(P. 37)
17	Tension bar initializing switch	Initializes the tension bar.
18	Feed switch	Rotates the X drive roller to feed the media. The take-up unit and feeding unit also operate in unison after the tension bar has been initialized.
19	Purified water tank	<ul style="list-style-type: none"> • Used to feed water to the moisturizing tray and to clean the wiper. • This should be provided by the customer. "Items to be Prepared by the Customer"(P. 30)
20	JOG button	Feeds the take-up unit and feeding unit respectively.

No.	Name	Overview
21	Rotation direction switch CCW/CW	Used to change the rotation direction of the take-up unit and feeding unit respectively.

Ink Supply Unit

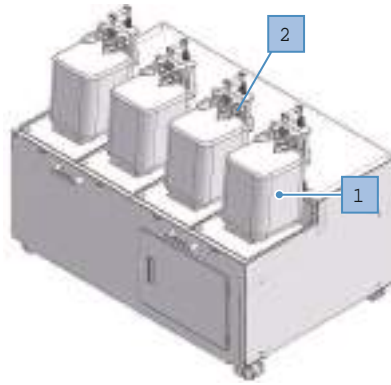

No.	Name	Overview
1	Ink tank	Mount the Ink tank. ☞ "Replacing the Ink Tank"(P. 52)
2	Cap cover	Lift up the lever to remove the Ink tank.

Winding unit

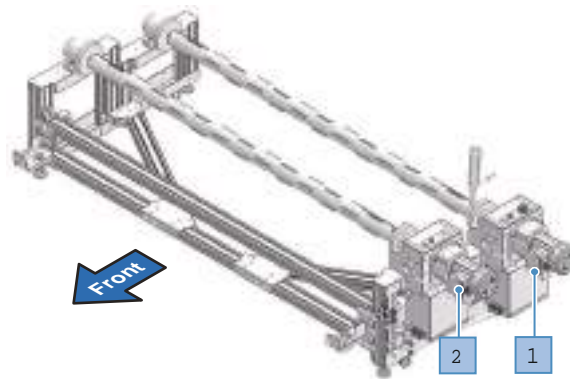

No.	Name	Overview
1	Take-up Unit	Rolls up the printed roll media. ☞ "Load the media."(P. 62)
2	Feeding unit	Loads the roll media prior to printing. Compatible with 3-inch paper cores.

Carriage

The carriage includes a print head for ejecting ink, and a jam sensor for stopping the carriage when media clogs. Printing occurs as ink is ejected while traversing left and right.



Station

The station includes a moisture tray for preventing the print head nozzle surface from drying out, and a wiper required for print head maintenance.

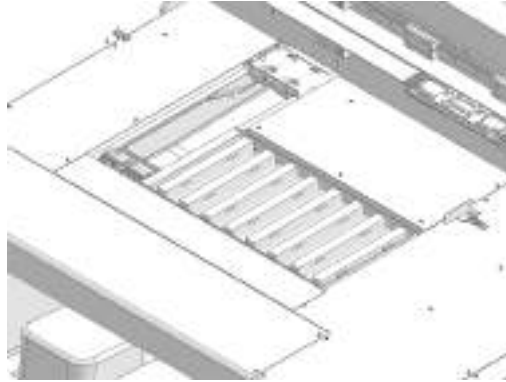

Platen

Print area. The platen secures the media under vacuum pressure.

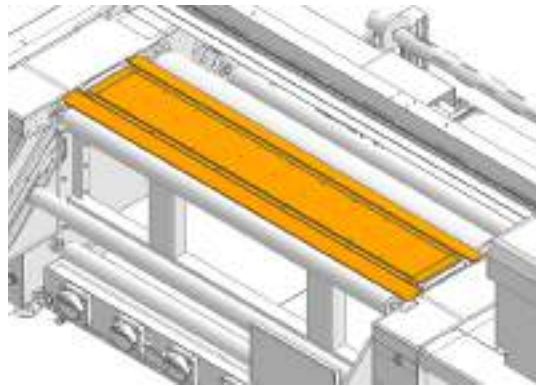

Light Curtain

The light curtain is used to stop the machine when a person or object is detected.

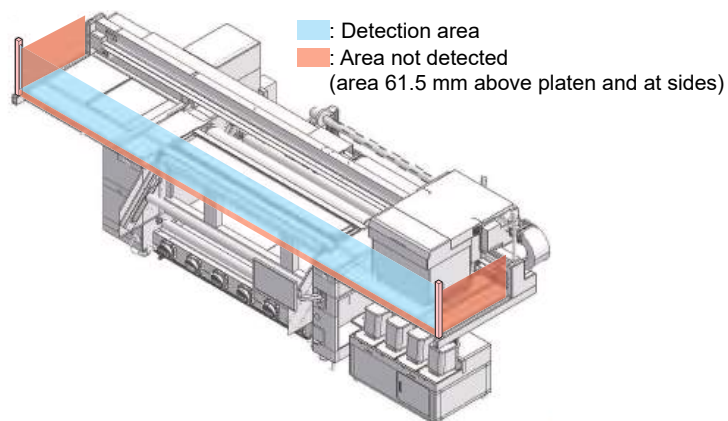

- Detection is not possible in the area up to 61.5 mm above the platen and in the areas at the sides. Parts of the body or other objects in this area cannot be detected. This can pose serious hazards because the carriage does not stop moving.

Signal tower light

The signal tower light allows the machine status to be confirmed from the color of the illuminated lights.



Color	Status	Overview
Red	Illuminated	Error level 2 or 3 ^{*1} occurrence Printing is not possible due to system failure.
	Off	The printer is operating normally.
Yellow	Illuminated	Error level 0 or 1 ^{*1} occurrence User action is required. (Printing is not possible for level 1 errors.)
	Off	The printer is operating normally.
Green	Illuminated	Standby state with the power turned on.
	Flashing	Indicates printing is underway.
	Off	Power turned off.

*1. Error levels

- 0: Information: Ink near end, etc.
- 1: Warning: Light curtain detection, etc.
- 2: Error: Ink leak, etc.
- 3: Emergency: Y limit sensor activated, etc.



- Printing cannot be started in level 1 or higher.

Drying unit

The drying unit consists of the drying heater and drying heater fan. It is located underneath the machine and dries the ink on the printed media.

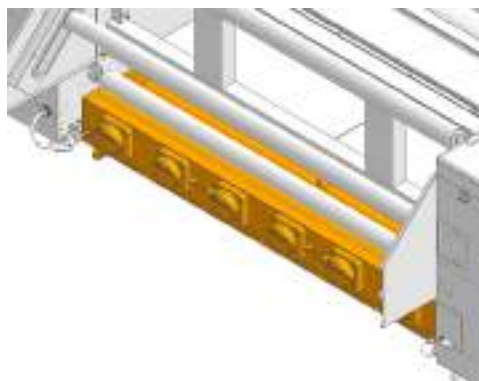

Maintenance Switch

Switch for selecting maintenance mode (MAINT) or print mode (PRINT).

Be sure to switch to maintenance mode before carrying out maintenance work.

The light curtain is disabled when in maintenance mode.  "Light Curtain"(P. 35)

[Maintenance mode selected]



[Print mode selected]

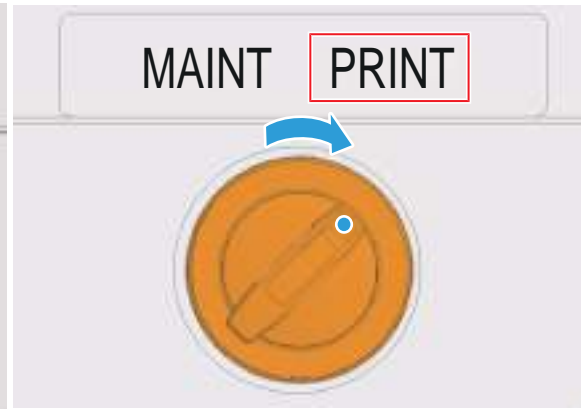

1.3 System Configuration

Use RIP software to prepare jobs (RIP data) from print data created in applications such as Illustrator or Photoshop.

Jobs prepared this way are printed using the MPC (Mimaki Printer Controller) application installed on the machine (control PC).  ["Settings \(MPC\)"\(P. 99\)](#)

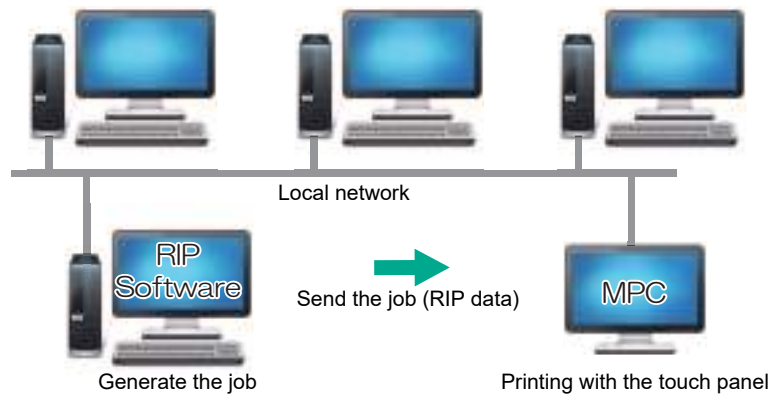

● Control PC



- Do not use a web browser when connecting the control PC to the Internet. Using a web browser can cause security risks.
- Do not install any software other than our specified software on the control PC. Also, do not use the MPC for any other purpose. Doing so may cause serious malfunctions such as the product not being able to start up or print.
- The control PC is connected to the machine with a LAN cable. Never disconnect the LAN cables connected to the machine, as shown in the red frames below.

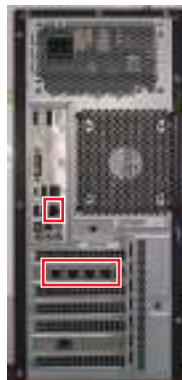

- Install the control PC no more than 2 m (ideally less than 1.5 m) away from the machine. (Because the LAN cable is 2 m long)

Connecting to a Local Network

Connect the machine (control PC) and RIP PC via a local network or direct LAN cable to enable jobs (RIP data) to be easily imported. Insert the LAN cable until it clicks into place.

● Machine (control PC) and RIP PC configuration

The machine can be connected using one of the following two methods:

- Connection using a LAN cable

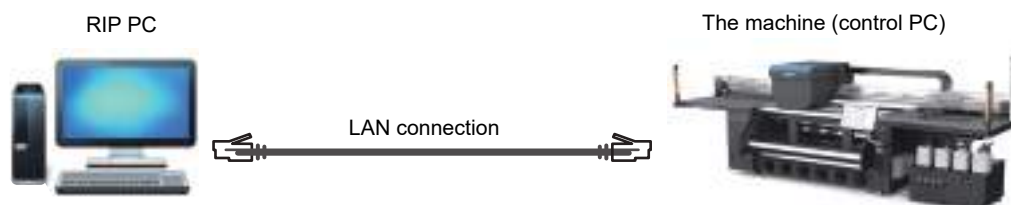

- Connection via a local network

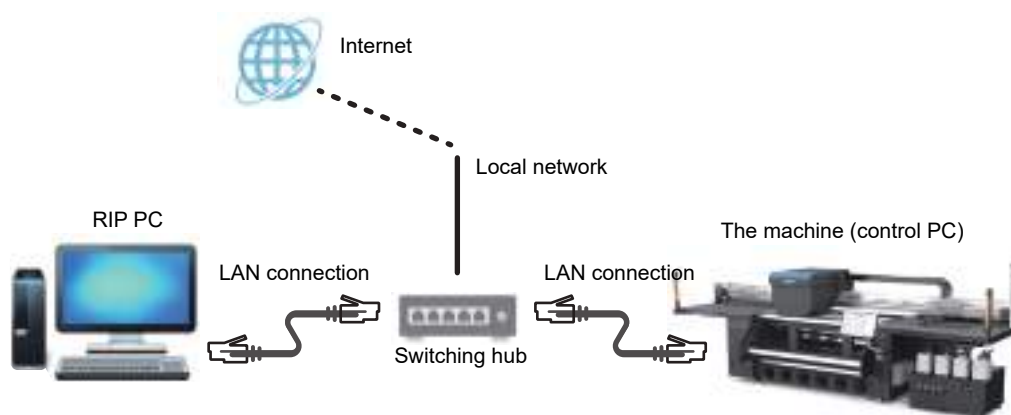

● LAN connection precautions

- Set up the control PC and the RIP PC to transfer print data on the same network. Connections via a router or using Wi-Fi are not possible.
- The following connection devices should be used for a local network connection.

Device	Required	Recommended
RIP PC LAN port	1 Gbps or higher	10 Gbps
LAN cable	CAT 6 or higher	CAT 6A or higher
Switching hub	1 Gbps or higher	10 Gbps

LAN connection checking method

● Check the machine (control PC) status

Check the LAN connector indicators near the bottom on the back of the control PC.

- The LAN connector indicators are illuminated when the system is connected.

- If the indicators are not illuminated, insert the LAN cable until it clicks into place.

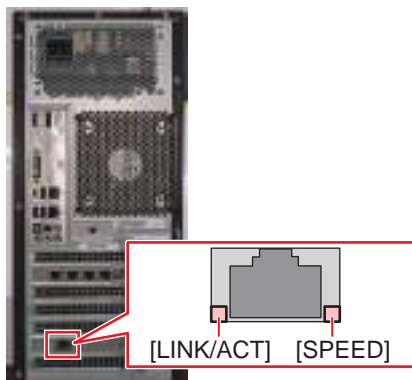

LED	Status	Overview
SPEED	Green	Linked via 10GBASE-T
	Yellow	Linked over a connection other than 10GBASE-T
LINK/ACT	Flashing green	Data is being sent and received.
	Green	No network traffic.



- Do not unplug the cable while data is being transferred.

● Check the touch panel

Check [Network setting] on the touch panel.



- Be sure to confirm whether the LAN connector indicator is lit before configuring the following settings.

- From MENU on the touch panel, tap [SETTING 2] > [System setting] > [Network setting]. Check the dialog box. If the LAN connection has been successfully established, the address will be displayed.

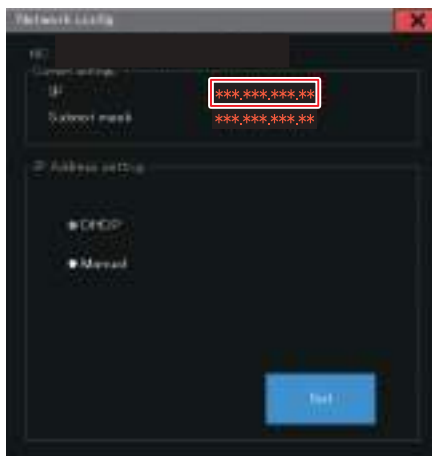

1.4 Preparing the RIP PC

RIP PC System Requirements

The customer should provide a RIP PC and network devices that meet the recommended requirements.



- TxLink cannot be installed on the Tiger600-1800TS control PC. The user must provide a separate PC for use with the RIP software. An Internet connection is also required in order to obtain the RasterLink license.

● Recommended RIP PC requirements

Item	Requirement
OS	Windows 11® Pro 64bit
Processor	Performance equivalent to intel® Core i7-7700K (4.2 GHz) or higher
Chipset	Genuine intel® chipset
Memory	8 GB or more
Storage	500 GB SSD ×2 or more
Network interface	10 Gigabit Ethernet * PCI Express X1 or higher is required when adding a 10 Gigabit Ethernet board to the PCI.
USB interface	USB 2.0 port (for connecting dongle)
Display	1,920 × 1,200 pixels or more
Optical drive	Optical drive capable of reading CD-ROM

● Recommended network environment

Item	Requirement
Network hub * Not required if the machine is directly to the RIP PC.	SW-HUB 10 Gigabit Ethernet compatible
LAN cable	CAT 6A or higher

Setting up an Ethernet connection

Sharing a Network

- 1 On the RIP PC, open the Windows start menu and click [Settings].

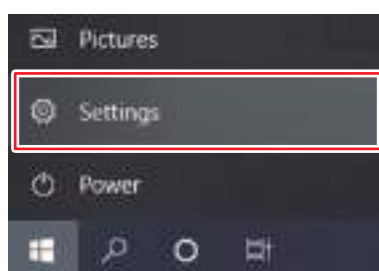

2 Select [Network & Internet].

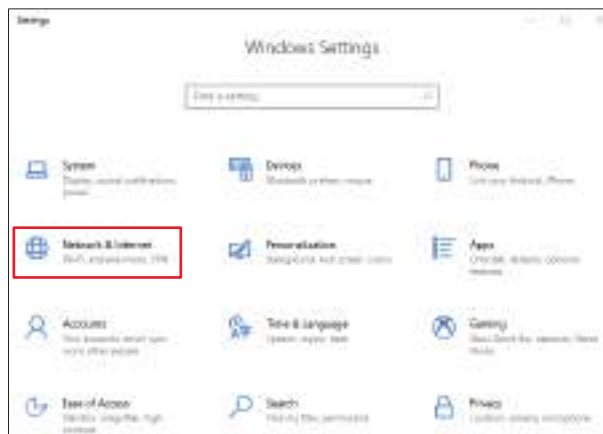

3 Under the "Change your network settings" section, select [Sharing options].

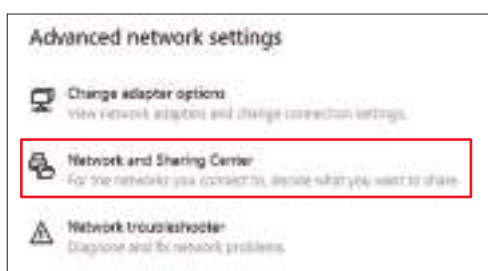

4 Select [Private], [Guest or Public], or [Domain].

- The selection items may vary depending on the network configuration. Contact your network administrator.

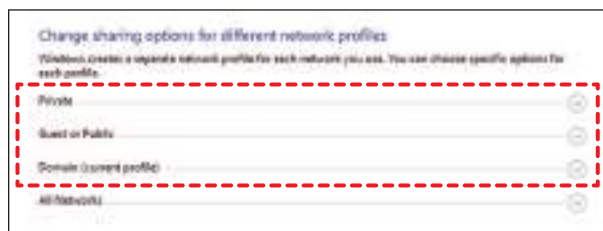

5 Select [Turn on network discovery] and click [Save changes].

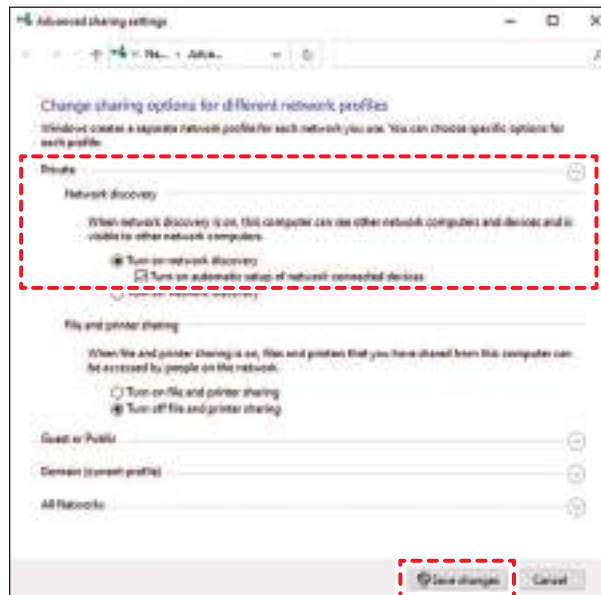

6 Restart the RIP PC.

Setting up an Ethernet connection

1 On the RIP PC, open the Windows start menu and click [Settings].

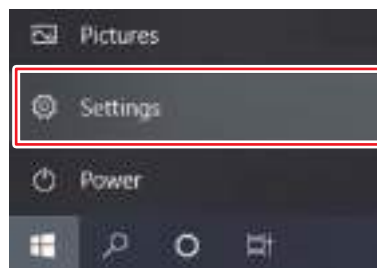

2 Select [Network & Internet].

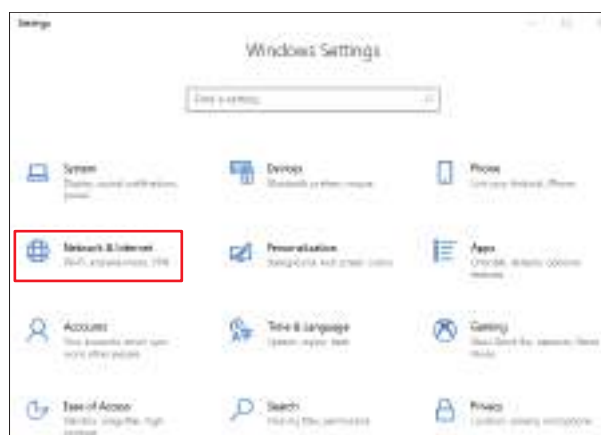

3 Select [Change adapter options].

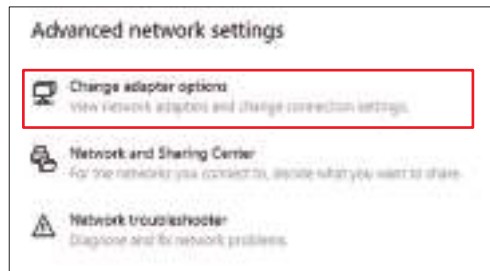

4 Right-click [Ethernet], and then select [Properties].

- If there are multiple [Ethernet] icons, select the properties for the port you wish to use.
- The names may vary depending on the PC.

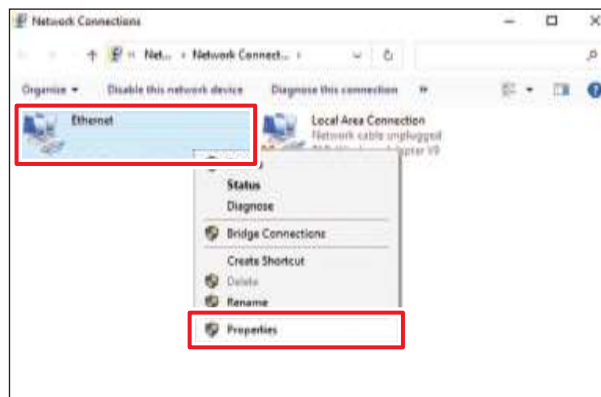

5 On the Networking tab, select the [Internet Protocol Version 4 (TCP/IPv4)] item, then click [Properties].

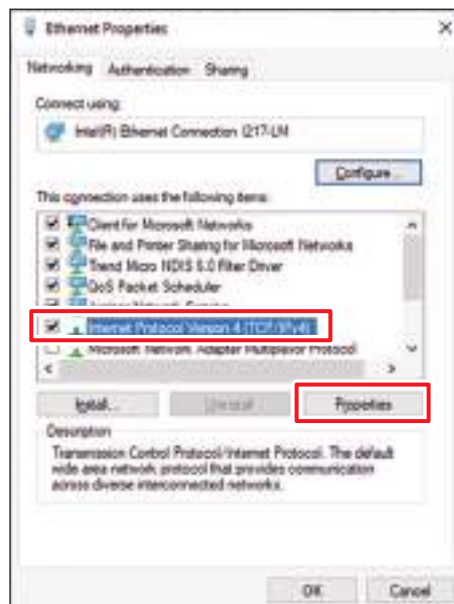

6 Configure the network settings.

- Configure the network according to the network settings of the control PC.
- For more information regarding the network settings of the control PC and RIP PC, contact your network administrator.



7 Restart the RIP PC.

8 Confirm that the connection has been established.

- Connect the RIP PC and control PC via a LAN cable. ["Connecting to a Local Network"\(P. 39\)](#)

9 Open Explorer on the RIP PC and enter [\machine serial number] in the address bar.

- The machine serial number can be checked on the touch panel (MENU > [SYSTEM] > [System information]).

10 Check the Explorer display.

- Check whether two folders, [HotFolder] and [SharedJob], are displayed. If they are displayed, configuration is complete.

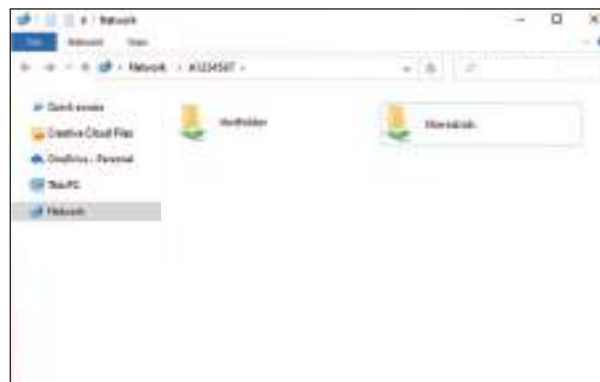

Installing RIP Software

The explanation here applies to the MIMAKI RIP software (TxLink).

- Important!** • If using TxLink, refer to the TxLink operating manual.

1 Install "TxLink".

- The following icon appears on the PC desktop once the software has been installed.



Setting Up RIP Software

The explanation here applies to MIMAKI RIP software (TxLink).

This section describes the procedure for registering the Tiger600 Series printer configuration.

1 Launch "TxLink".

- If no printer configuration has yet been registered, a guide to creating the printer configuration will be displayed when first launched. Click [Add], then proceed to step 3.

2 The add printer configuration window appears.

- (1) Click the printer configuration button at the top of the window.



- (2) Click [Add].

3 Create a print client.

- (1) Click the [+] button.
- (2) Select the desired printer driver, then click [OK].
 - Open the Mimaki Tiger600-1800 folder.



- (3) Select a port.



- If the port is not listed in the combo box, follow these steps to create it.
 - (1) Click [Add Port].
 - (2) Select the type of port for the connection and click [Yes].
 - File Interface: Sends jobs to the RIP computer.
 - MIMAKISTATUSPORT: Sends jobs to the machine (control PC) over the local network.

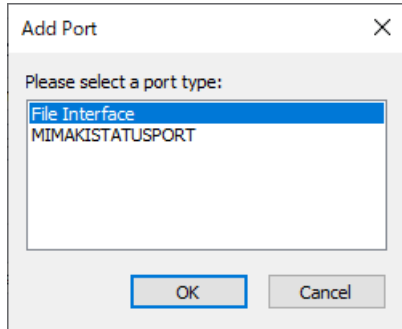

● **When File Interface is selected**

- (1) Select a folder for job output and click [OK].

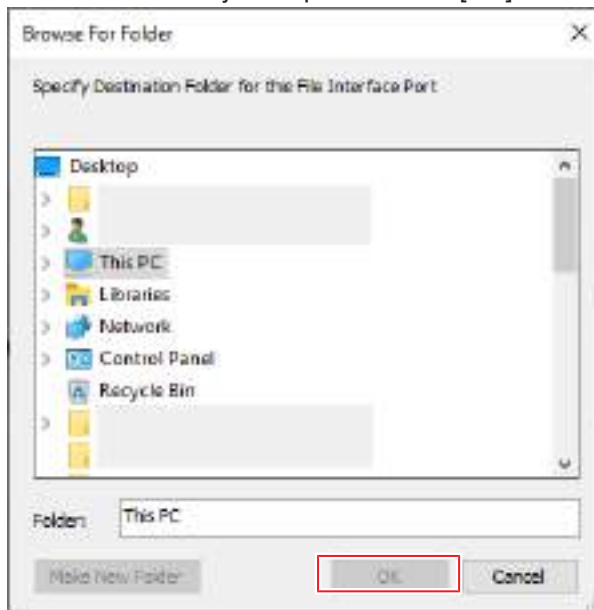

● **When MIMAKISTATUSPORT is selected**

- (1) Join the local network.  "Connecting to a Local Network"(P. 39)
- (2) In [Destination Folder], enter the path of the shared folder for job output.

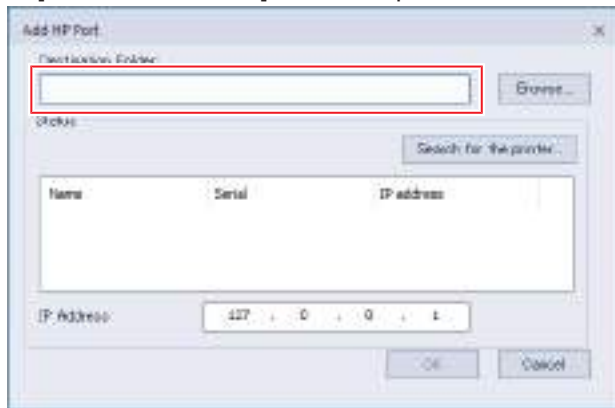

- The output shared folder can be selected from the following:
 - SharedJob: To print from [Job List] on the touch panel (Ex.: [*****\SharedJob])
 - HotFolder: To print automatically (Ex.: [*****\HotFolder])
- (3) Click [Search for the printer].
- The printer list at the bottom of the UI is updated.

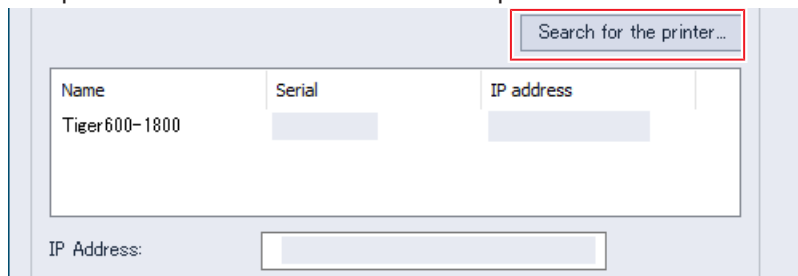

- (4) In the printer list, select the printer to connect, then click [OK].



- Please change "*****" to the serial number of the printer.
- From MENU on the touch panel, tap [SYSTEM] > [System information] to display the serial number on the browser screen at right.

4 Select the type of status monitor.

- Mimaki Textile: Monitors the printer on a regular schedule and displays the status in the print client window. See Step 5 of  "Creating RIP Data"(P. 84).
- None: Printer status is not monitored.

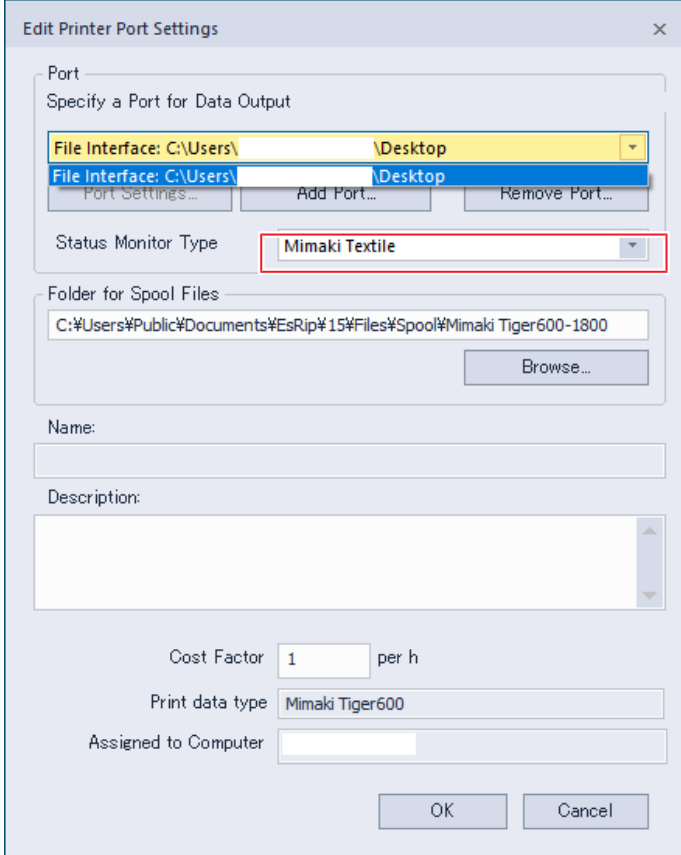

The screenshot shows the 'Edit Printer Port Settings' dialog box. The 'Port' section is expanded, showing a list of ports with 'File Interface: C:\Users\... \Desktop' selected. Below this, the 'Status Monitor Type' dropdown menu is highlighted with a red box and set to 'Mimaki Textile'. The 'Folder for Spool Files' section contains the path 'C:\Users\Public\Documents\EsRip\15\Files\Spool\Mimaki Tiger600-1800'. The 'Name' and 'Description' fields are empty. The 'Cost Factor' is set to 1 per h, and the 'Print data type' is set to 'Mimaki Tiger600'. The 'Assigned to Computer' field is empty. The 'OK' and 'Cancel' buttons are at the bottom.

5 Click [OK].

6 Set an appropriate name for the print client, then click [OK].

- The printer configuration is then created.

7 Click [Print settings] > [Printing assignment], set the ink for each slot, then click [OK].

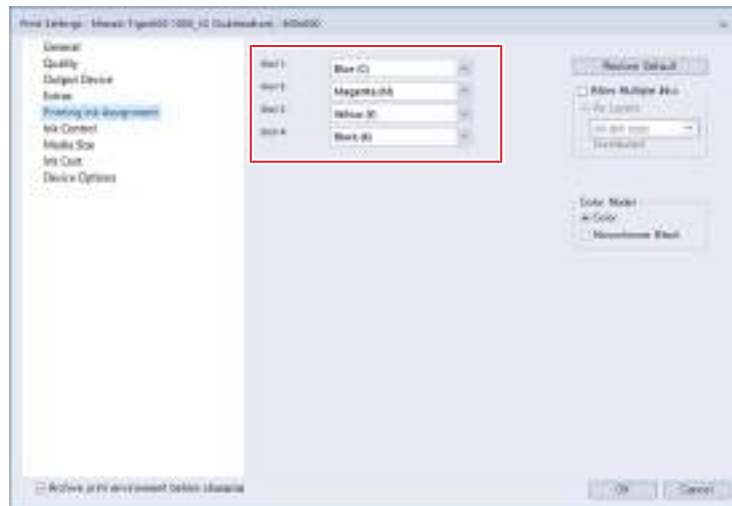

1.5 Ink Tank Replacement Method

When Ink Near End is Displayed

Ink levels are low. We recommend replacing with new Ink tank as soon as possible. Note that ink may run out during printing.

You can check which Ink tank must be replaced in INK STATUS on touch panel.  ["INK STATUS"\(P. 102\)](#)



When Ink End is Displayed

The ink has run out. Replace with new Ink tank.

Thoroughly read the following and make sure you understand its contents.

 ["Ink and Other Liquid Handling Precautions"\(P. 19\)](#)



- Pay close attention to ventilation and be sure to wear safety glasses, gloves, and a mask when handling ink, maintenance liquid, waste ink, or other solutions used with the machine. Leaking ink may adhere to the skin or get into the eyes or mouth.



Replacing the Ink Tank

Replacing the ink tank

● Remove Ink tank

1 Lift up the cap cover.

- The machine detects that the cap cover is detached, allowing the tank to be removed.

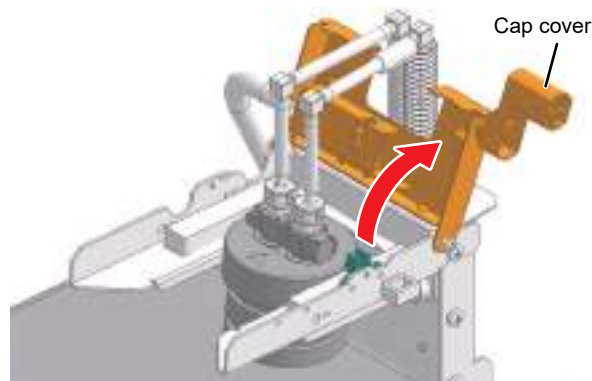

2 Remove the fitting from the Ink tank cap.

- Press down on the fitting latch, then pull out the fitting.

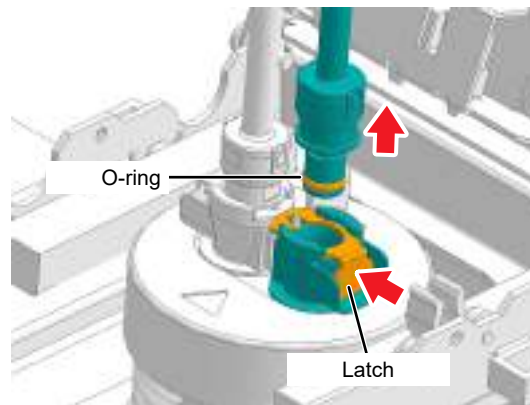

- Be sure to press down the latch fully to remove the fitting. If you try to force off the fitting without pressing down the latch fully, there is a risk of damaging the O-ring on the fitting, which may cause ink leakage.

3 Remove the other fitting in the same way.

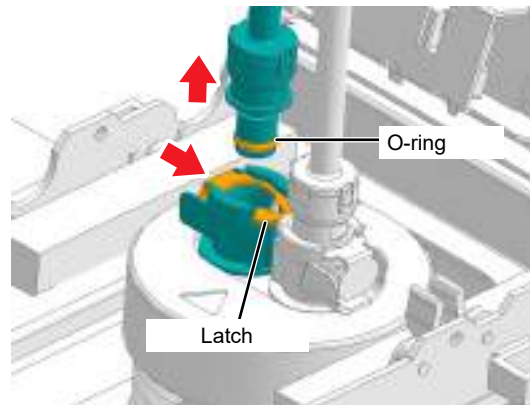

4 Press the tip of the fitting lightly against the ink wiping sponge to prevent ink dripping from the tip of the fitting.

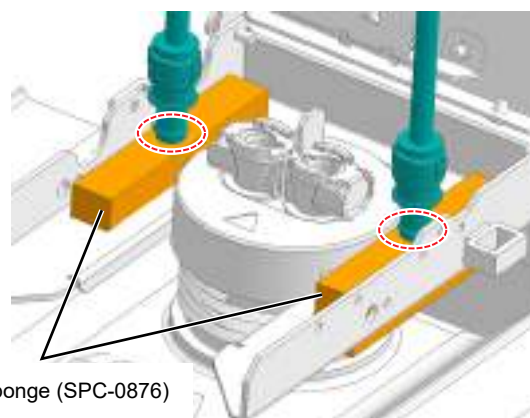

Ink wiping sponge (SPC-0876)



- Do not press the valve at the tip of the fitting in firmly. If the valve is pushed in, ink may leak out, and air may enter the ink paths, causing malfunctioning.

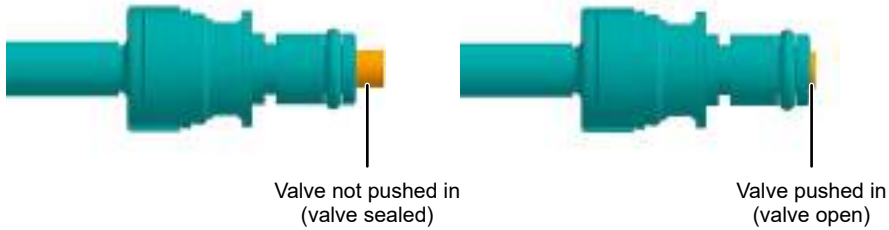

5 Remove the Ink tank from the ink supply unit.

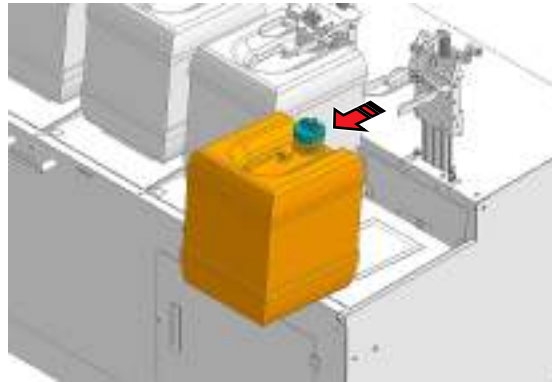

- When disposing of liquids used with the machine (such as ink or maintenance liquid) or containers, paper towels, or the like with this residue on them, contact an industrial waste disposal operator or dispose of in accordance with local laws and regulations.

● Prepare Ink tank

1 Shake the new Ink tank gently from left to right to ensure it is fully mixed.

- Tighten the Ink tank lid securely, then move from left to right to ensure that the ink moves inside, holding the lid with a paper towel.

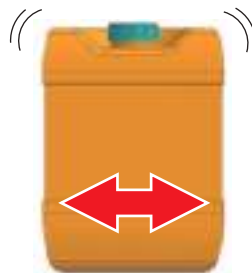

● SetInk tank

- 1 Remove the Ink tank cap, then attach the new Ink tank.

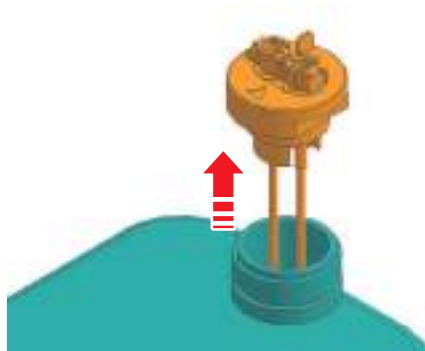

- When disposing of liquids used with the machine (such as ink or maintenance liquid) or containers, paper towels, or the like with this residue on them, contact an industrial waste disposal operator or dispose of in accordance with local laws and regulations.

- 2 Mount the new Ink tank in the supply unit, then attach the fitting.

- Insert the fitting with the fitting latch pressed down.

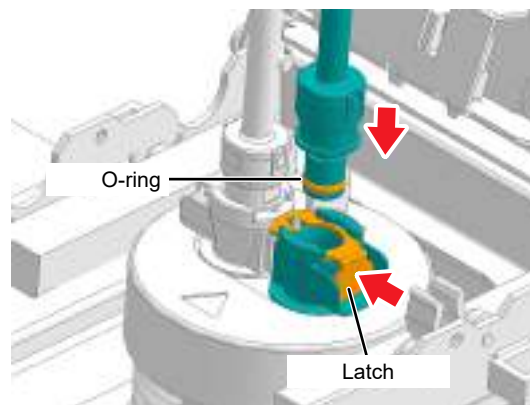

- Be sure to press down the latch fully when inserting the fitting. If you try to forcibly insert the fitting without pressing down the latch fully, there is a risk of damaging the O-ring on the fitting, which may cause ink leakage.
- Take care not to push in the valve at the tip of the fitting when connecting the fitting. If the valve is pushed in, ink may leak out, and air may enter the ink paths, causing malfunctioning.



Valve not pushed in
(valve sealed)



Valve pushed in
(valve open)

3 Attach the other fitting in the same way.

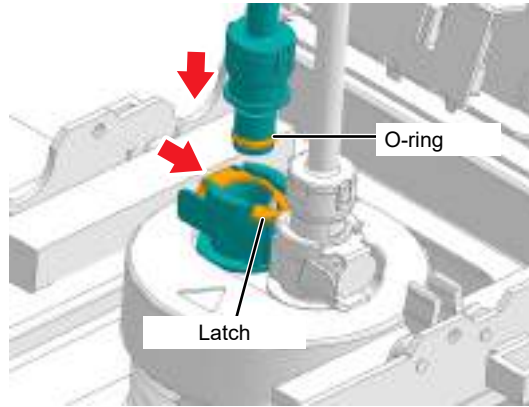

4 Check to confirm that the fittings are securely connected.

(1) There are no gaps in the fittings.

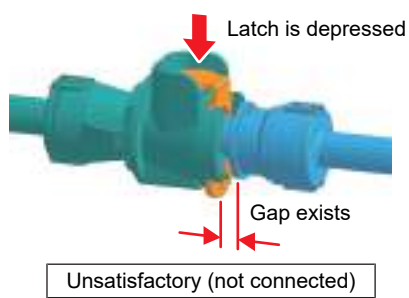
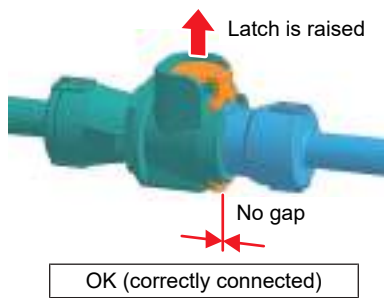

(2) The fittings do not detach when pulled gently.

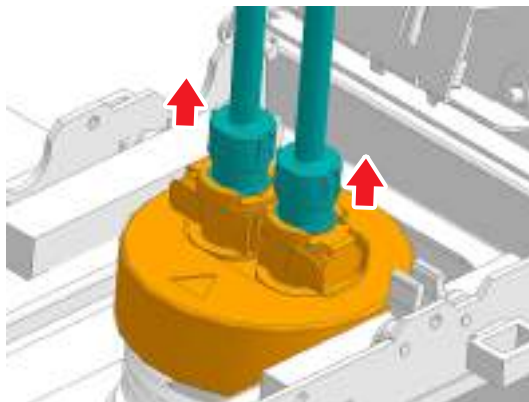

5 Lower the cap cover.

- When closing the cap cover, make sure the sensor shade is inserted inside the slot in the cap sensor.

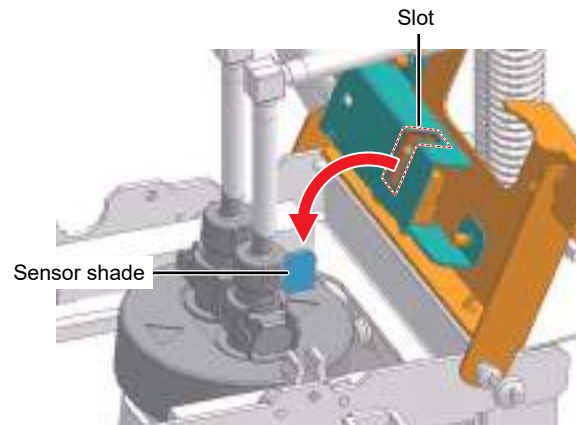

6 Tap the [CLEAR ALARM] button on the touch panel.

Chapter 2 Printing



This chapter

This chapter describes printing procedures and settings.

Print Process	60	Head Cleaning.....	80
Load the media.....	62	Cleaning	80
Media	62	Powerful Cleaning.....	80
Preparation.....	64	Correcting the Drop Position	82
Loading the Media on the Feeding Air Shaft	66	Preparing a Job (RIP Data).....	83
Loading the Paper Core on the Take-up Air Shaft.....	69	With Output Port Set to	
Loading Media on to the Printer Main Unit. 71		[MIMAKISTATUSPORT]	83
Setting the Head Gap.....	77	With Output Port Set to [File Interface]	89
Checking the Head Gap Value.....	77	Printing	93
Test Printing	78	Starting Printing	93
Checking Print Head Discharge	78	Stopping Printing.....	95
Ejection Failures.....	79	Skipping the wait until heater temperature is reached	95
		Printing Using Nozzle Recovery	96

2.1 Print Process

1. Setting Up RIP Software

- ☞ "Installing RIP Software"(P. 45) (required first time only)
- ☞ "Setting up an Ethernet connection"(P. 41) (required first time only)

2. Set up the control PC and RIP PC on the same local network.

- ☞ "Connecting to a Local Network"(P. 39) (required first time only)
 - If the system is not connected to a local network, you can use a removable disk to store jobs (RIP data) in MPC.☞ "With Output Port Set to [File Interface]"(P. 89)

3. Load the media.

- ☞ "Load the media."(P. 62)

4. Setting the Head Gap

- ☞ "Setting the Head Gap"(P. 77)

5. Check the state of the print head nozzles.

- ☞ "Test Printing"(P. 78)

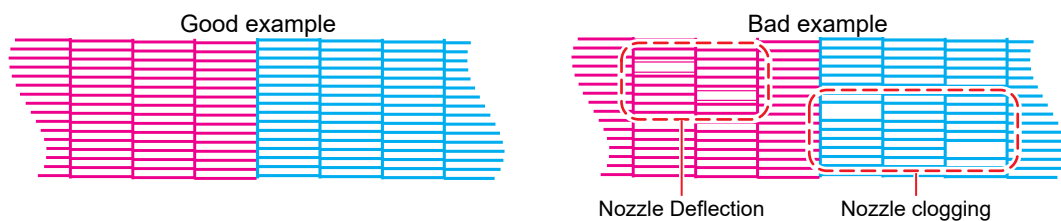

6. Clean the head to clear malfunctioning nozzles.

- ☞ "Head Cleaning"(P. 80)

7. Adjust the drop position for bi-directional printing.

☞ "Correcting the Drop Position"(P. 82)

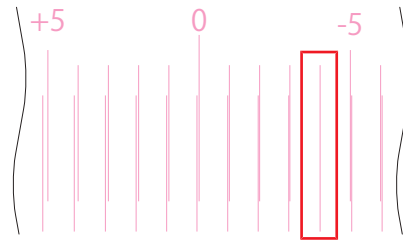

In this case, the drop position correction value is -4.0

8. Import the job (RIP data) into MPC.

☞ "Preparing a Job (RIP Data)"(P. 83)

9. Print the job (RIP data).

☞ "Printing"(P. 93)

2.2 Load the media.



- Adjust the head height before loading media. Moving the carriage after the media has been loaded may result in the print head coming into contact with the media and being damaged.

Media

● Media handling precautions



- Use Mimaki-approved media to ensure consistent high-quality printing.

⚠ WARNING



- Assign at least two people to load roll media. Otherwise there is a risk of back injury due to the weight of the media.

NOTICE



- When using a lifter to load the media, check the lifter specifications before commencing.



- An air compressor is required for loading the media (recommended pressure 0.5 MPa).



- Do not use media soon after it has been removed from its packaging. The media may stretch or shrink depending on the temperature and humidity of the location in which it is stored. Allow the media to stand for at least 24 hours in the same indoor conditions as the machine before loading on to the machine.
- Adjust the indoor conditions to suit the media used.
- Do not use media with wrinkles or misaligned roll edges. Disregarding this precaution may affect print quality.



- Store unopened media in a cool, dry location away from direct sunlight.
- Take care to avoid touching the media surface (particularly the printing surface) after opening.
- If the media is left out for extended periods, such as overnight, wrap plastic sheeting or similar at least once around the exterior of the media. This will help prevent any effects from ambient condition variations.

● Lifter specifications

Item	Requirements
Load capacity	Min. 350 kg
Fork length	800 mm or more
Fork width	500 to 700 mm (fork external dimension)
Minimum height	Max. 150 mm
Maximum height	500 mm or more
Recommended lifter	HC-10B-70 (load capacity 1,000 kg)

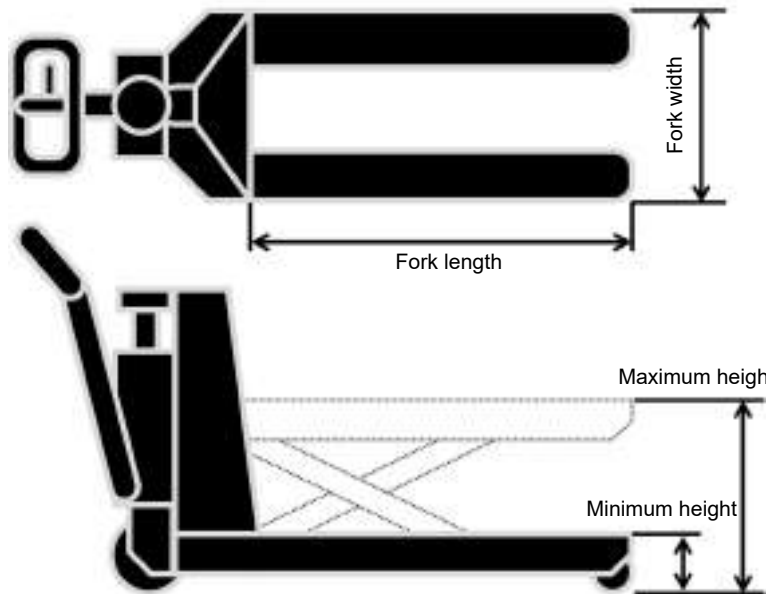

Preparation

- 1 Tap [SET 2] > [Media] > [Set media] on the touch panel.
- 2 Switch the maintenance switch to maintenance mode.  ["Maintenance Switch"\(P. 37\)](#)
- 3 Lower the two tension bars on the take-up and feeding sides.
- 4 Tap [Feeding] > [Rotate roll to removable position] on the touch panel to rotate the air shaft until the air shaft inlet is facing upward.

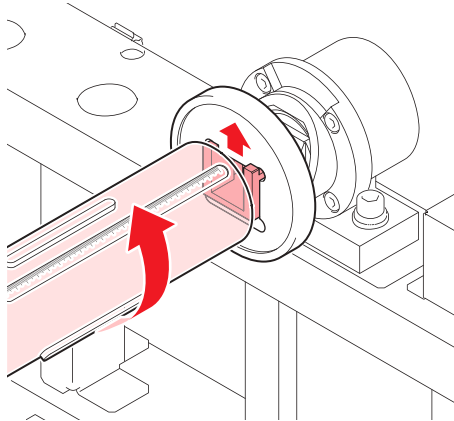

- 5** Tap [Winding] > [Rotate roll to removable position] on the touch panel to rotate the air shaft until the air shaft inlet is facing upward.

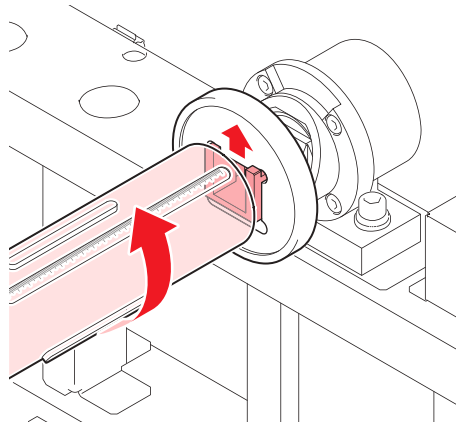
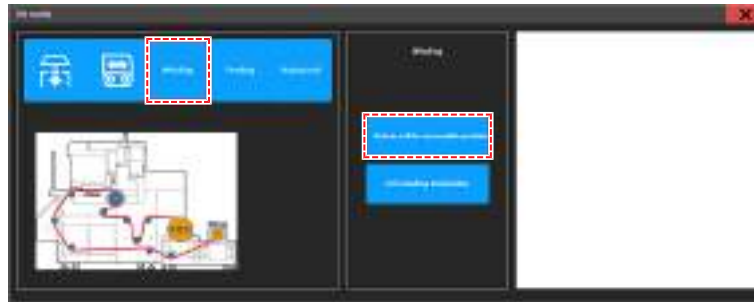

- 6** The two tension bars on the feeding side and the take-up side are evacuated.

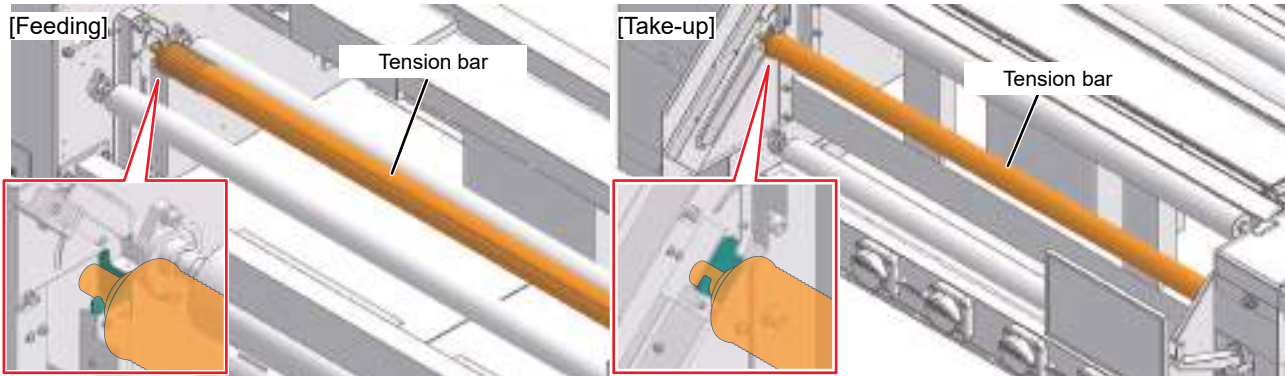

- Lift the tension bar horizontally (two-person operation recommended). Failure to lift the tension bar horizontally may cause the tension bar to fail to operate properly.

Loading the Media on the Feeding Air Shaft

1 Tilt the shaft clamp.

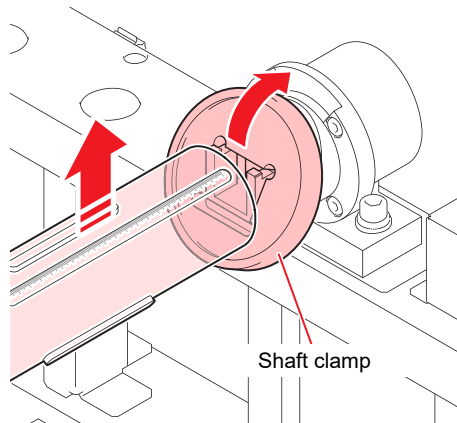

- Before tilting the shaft clamp, be sure to check that the air shaft inlet is facing upward.



- The shaft will not rotate unless the power is turned on.
- Be careful to avoid catching your hands or fingers when using force to move the shaft clamp.
- The shaft clamp movement is made stiff to ensure safety. A plastic hammer or similar can be used if it is difficult to move.

2 Remove the air shaft.

3 Insert the feeding air shaft into the media roll.

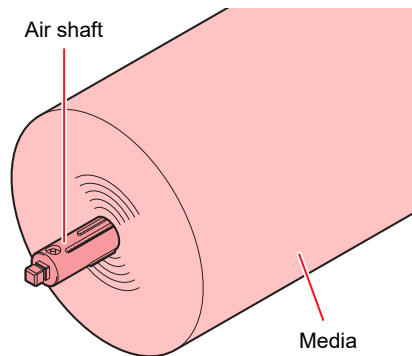

- 4** Adjust the air shaft position, then use the air nozzle provided to feed air into the air shaft and secure the media.

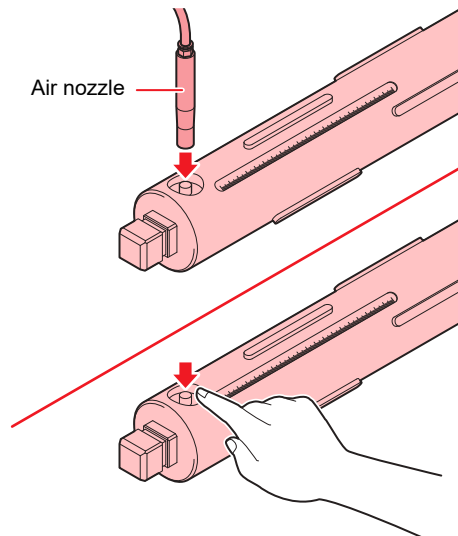

- Load so that the readings are identical on the scales at both ends of the air shaft.
- Be sure to mount with the air shaft inlet on the motor side.

Air shaft inlet

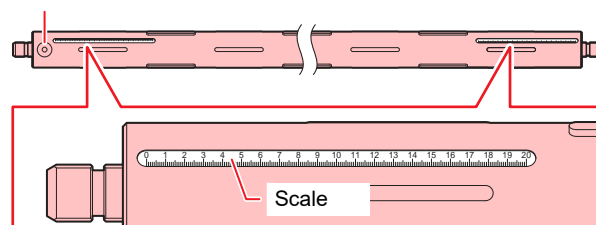

Media loading position



- Reference: For a media width of 1,620 mm, the readings should be approximately 14.5 mm on both left and right.



- If the air is insufficient, the media may slip, causing feeding problems.
- Pressurizing until the paper tube is deformed may cause transport failure. Recommended pressure : 0.5 MPa



- When using a lifter, supply the air with the media placed on the lifter.
- Place the media on the lifter forks and adjust the angle so that the air shaft can be inserted into the grooves.

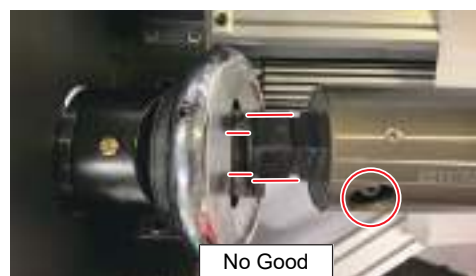
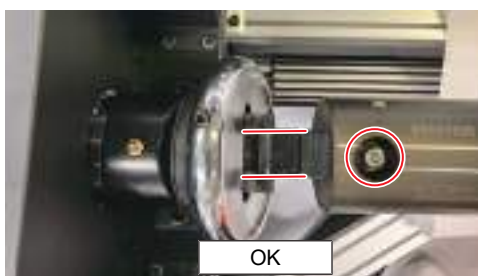

5 Move the media to the feeding shaft clamping position.

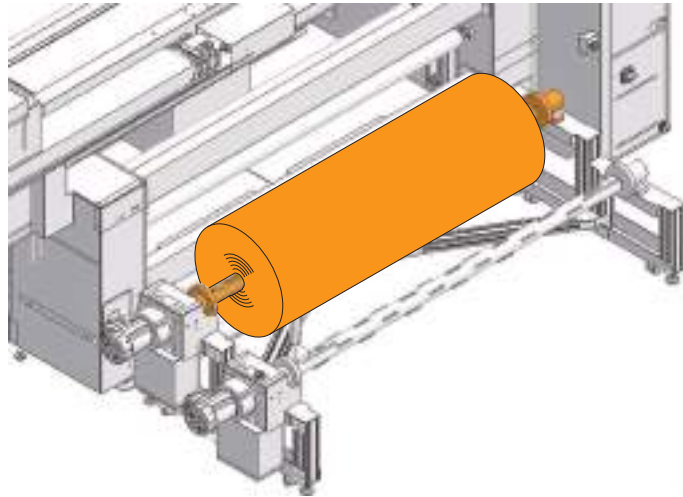

- When using lifter
When using a lifter, remove the front take-up air shaft.

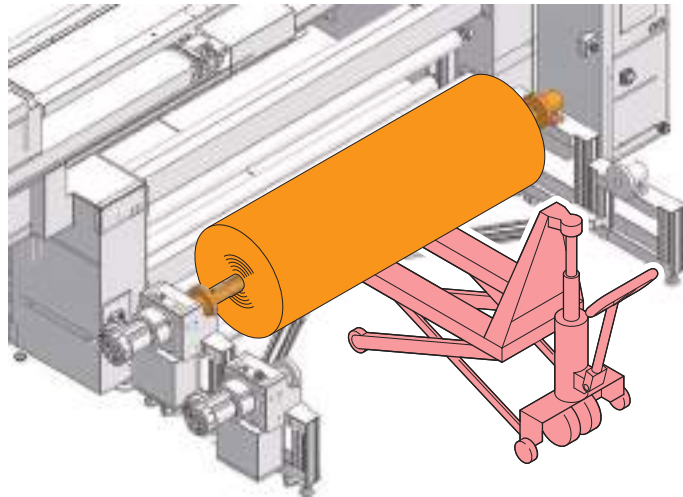

6 Lower the media and clamp the feeding shaft.

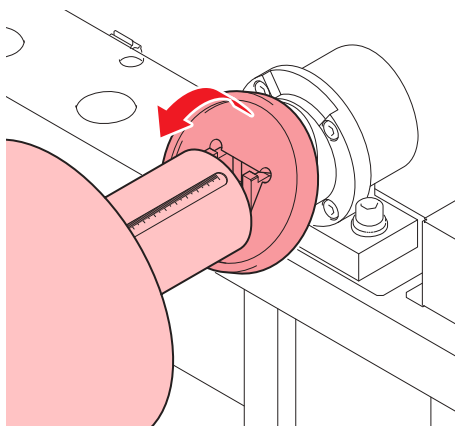

- Be sure to clamp the shaft securely. There is a risk of the air shaft falling off if the media is rotated without clamping it, posing hazards.



- Be careful to avoid catching your hands or fingers when using force to move the shaft clamp.
- The shaft clamp movement is made stiff to ensure safety. A plastic hammer or similar can be used if it is difficult to move.

Loading the Paper Core on the Take-up Air Shaft

1 Tilt the shaft clamp.

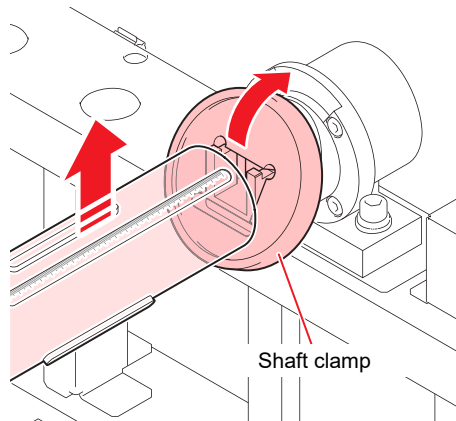

- Before tilting the shaft clamp, be sure to check that the air shaft inlet is facing upward.



- The shaft will not rotate unless the power is turned on.
- Be careful to avoid catching your hands or fingers when using force to move the shaft clamp.
- The shaft clamp movement is made stiff to ensure safety. A plastic hammer or similar can be used if it is difficult to move.

2 Remove the air shaft.

3 Insert the take-up air shaft into a new paper core.

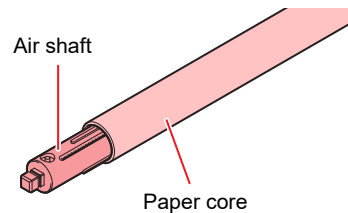

4 Adjust the air shaft position, then use the air nozzle provided to feed air into the air shaft and secure the paper core.

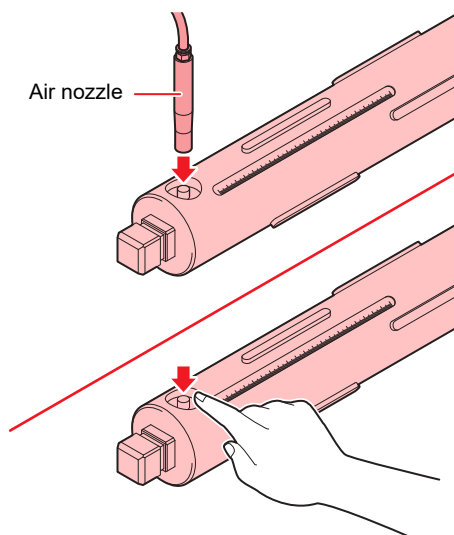



- Load so that the readings are identical on the scales at both ends of the air shaft.
- Be sure to mount with the air shaft inlet on the motor side.

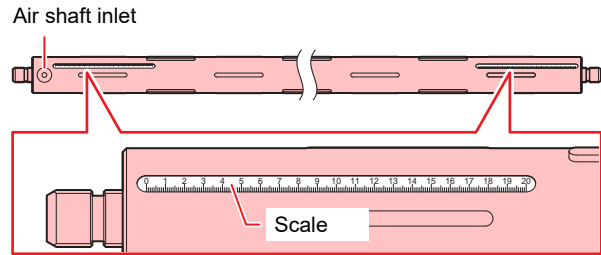

Paper core loading position



- If the air is insufficient, the paper core may slip, causing feeding problems.
- Pressurizing until the paper tube is deformed may cause transport failure. Recommended pressure : 0.5 MPa

5 Clamp the take-up shaft.

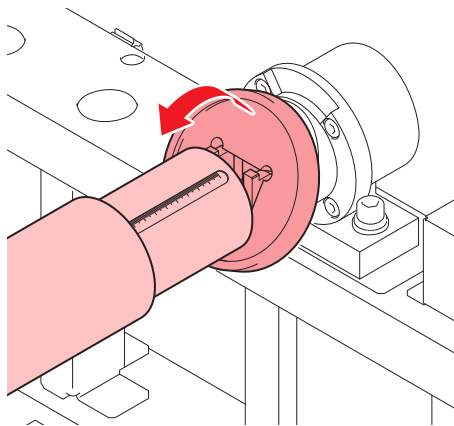

- Be sure to clamp the shaft securely. There is a risk of the air shaft falling off if rotated without clamping it, posing hazards.



- Be careful to avoid catching your hands or fingers when using force to move the shaft clamp.
- The shaft clamp movement is made stiff to ensure safety. A plastic hammer or similar can be used if it is difficult to move.

Loading Media on to the Printer Main Unit

1 Feed the media through to the printer main unit.

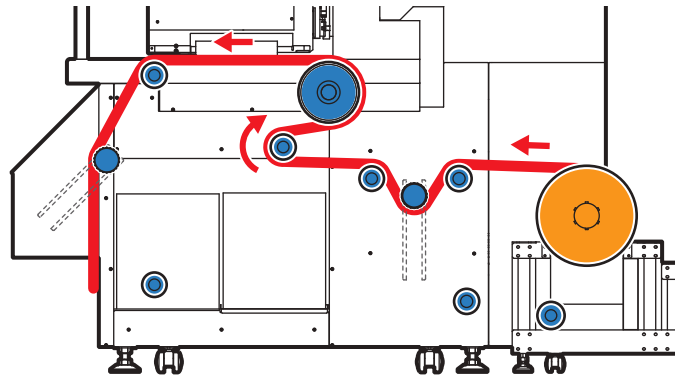

(1) Feed the media through with the tension bar raised.

- Use the feeding JOG switch to feed the media.
- Turn the rotation direction switch to CCW.

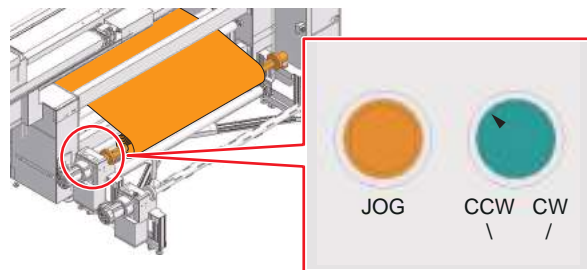

(2) Feed the media as far as the printing surface.

- Pull the media out from the platen side at the front, and use the rear feed switch and feeding JOG switch to feed the media.

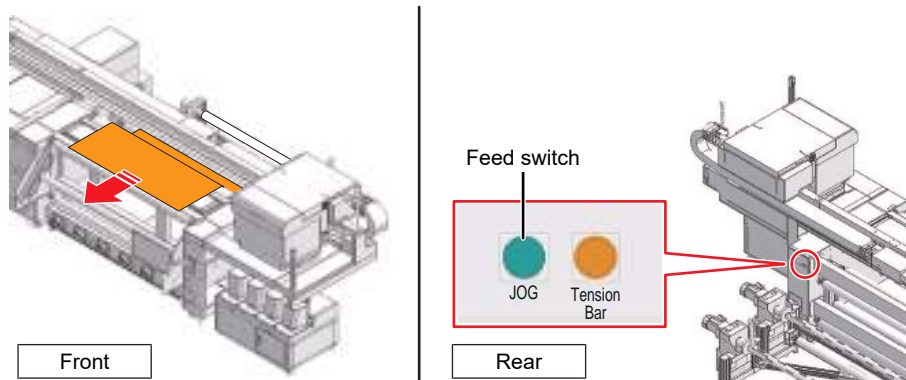

- This operation is made easier with two persons, one at the front and one at the rear.

2 Feed the media underneath the printer main unit.

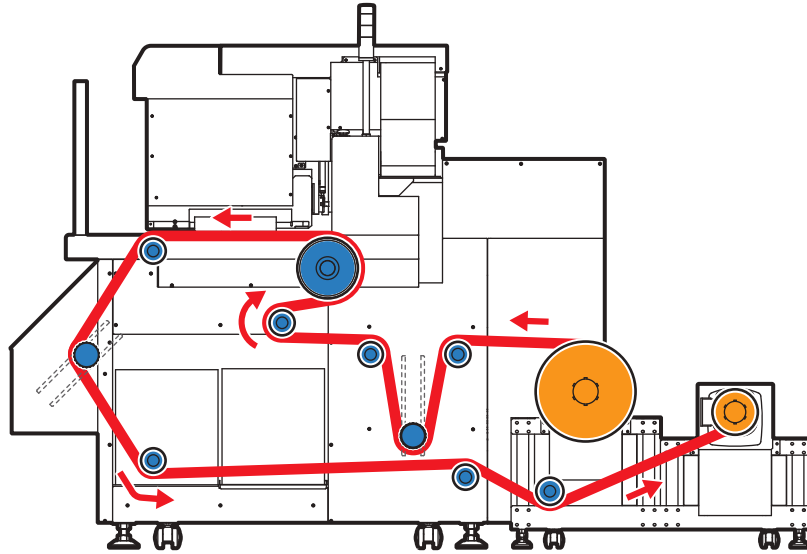

- To set the media in the Take-up paper core, about 6 m of media must be fed.

(1) Tap [Drying unit] > [Drying unit Taking out] on the touch panel, then pull out the drying unit.

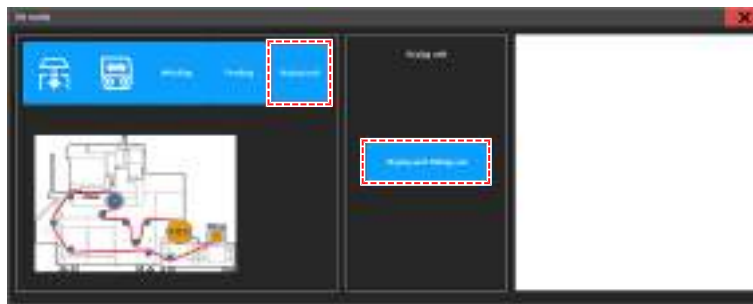

(2) Use the feeding JOG switch to feed out the media.

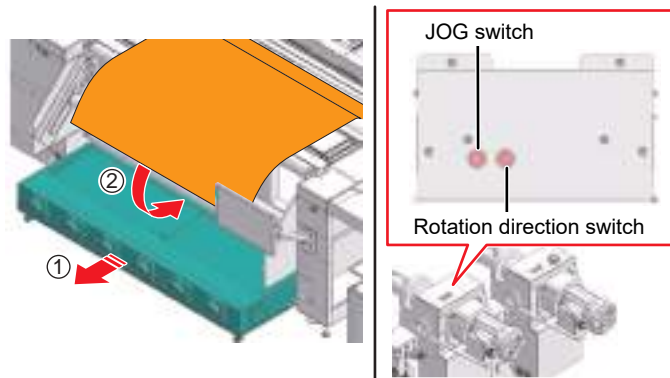

- Pulling out the drying unit then securing the fed media to the drying unit (with adhesive tape or magnets, etc.) makes it easier to feed the end.

3 Press the feeding JOG switch to feed the media.

- Feed the media to the position where it can be wound on to the paper core.

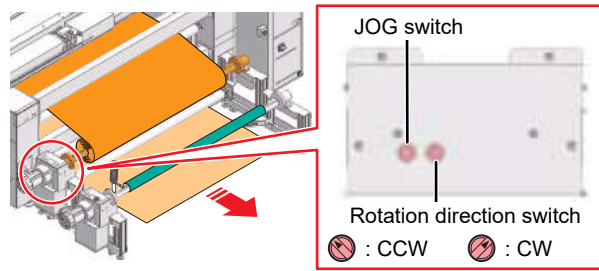

4 Secure the media to the take-up paper core.

- Secure the media with adhesive tape.



- Pull the roll media evenly on both the left and right sides, aligning both edges, check to confirm that it is free of sagging and creasing, then affix the tape.

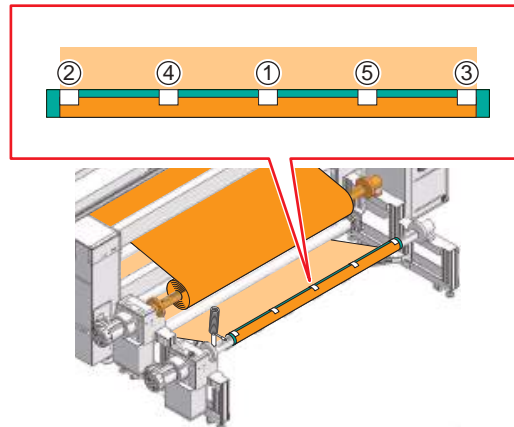

5 Press the feeding JOG switch to feed the media.

- Feed the media to the position where the take-up tension bar can be lowered.

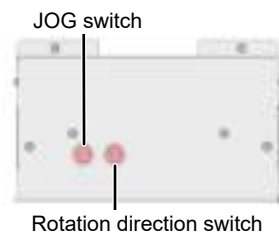

6 Lower the tension bar.

- Use the feeding JOG switch to feed out the media until the tension bar lowers to its lowest position.

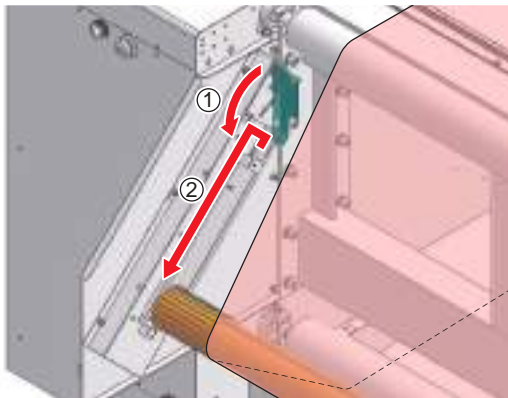

- Support the tension bar in your hand while lowering it. The tension bar may drop if the stopper is released without supporting it, posing hazards.

7 Lower the feeding tension bar.

- Use the feeding JOG switch to feed out the media until the tension bar lowers to its lowest position.

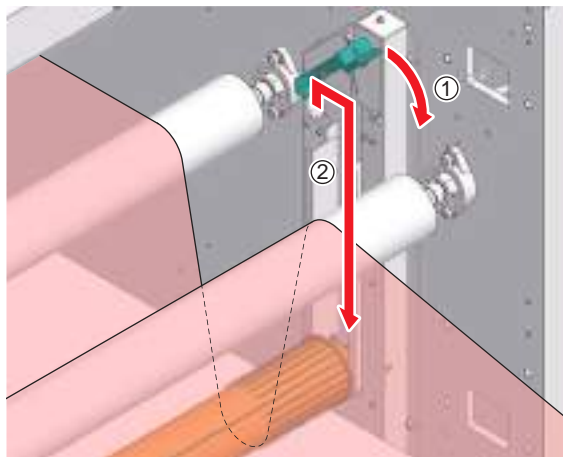

- Support the tension bar in your hand while lowering it. The tension bar may drop if the stopper is released without supporting it, posing hazards.

8 Press the feeding JOG switch to feed the media.

9 Press the take-up JOG switch and feed switch to wind the media at least five times around the paper core.

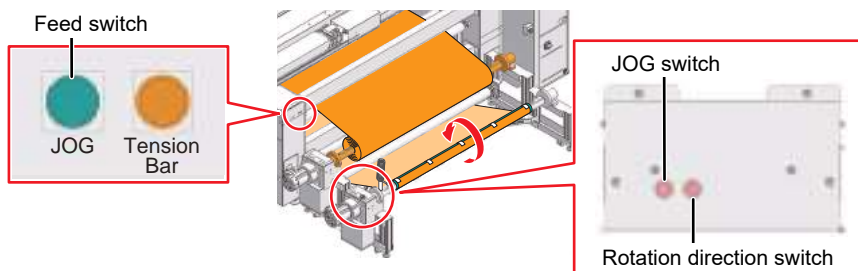



- Check to confirm that the media edges are not misaligned.
- Wind so that the take-up tension bar cannot rise fully.



- If there is insufficient media, press the feeding JOG switch and feed switch to feed out the media.

10 Tap [Set media] > [Winding] on the touch panel, then press the Tension Bar switch.

- The Take-up tension bar is initialized automatically.



If an error occurs:

- Use the JOG switch to lower the tension bar to its lowest position, and try again. When repeating the procedure, be careful so that the media does not sag down.

11 Tap [Set media] > [Feeding] on the touch panel, then press the Tension Bar switch.

- The feeding tension bar is initialized automatically.



If an error occurs:

- Use the JOG switch to lower the tension bar to its lowest position, and try again. When repeating the procedure, be careful so that the media does not sag down.



- Pressing the feed switch after initializing the tension bar also feeds the feeding and take-up units in unison with the X drive roller.
- Pressing the tension bar switch on the back of the printer initializes both the Feeding and Take-up tension bars.

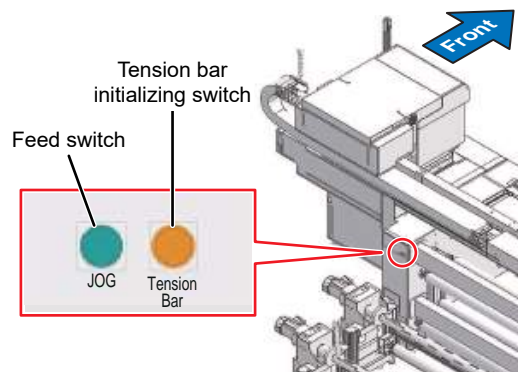

12 Tap [Forward feed] on the touch panel.

- The tension bar operates.

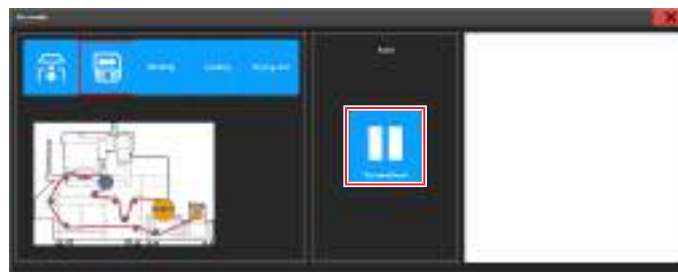

13 Switch the maintenance switch to print mode. "Maintenance Switch"(P. 37)

14 Load the media in the media holders.

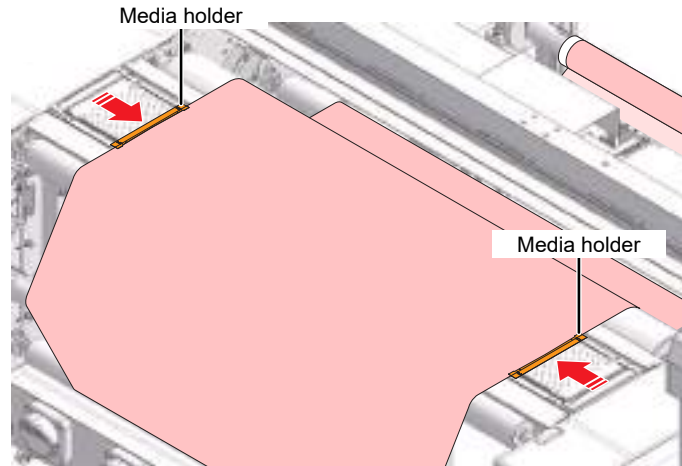

15 Turn on the platen vacuum.



- Be sure to check the ink levels and waste ink level before starting printing. Printing will stop midway if there is insufficient ink.



- Be careful to avoid objects being dragged into the take-up unit during printing (during take-up). Otherwise, there is a risk of clothing etc. being dragged in. Where this is unavoidable, for example when checking print quality, either pause printing or peer inside while holding the emergency box.

2.3 Setting the Head Gap

Set the height from the media to the print head nozzle surface.



- Be sure to correct the dot position after altering the print head height.  ["Correcting the Drop Position"\(P. 82\)](#)
- Adjust the print head height to suit the media. With inkjet printers, if the gap between the print and media increases, the ink droplets may vaporize before they reach the media. Vaporized ink may adhere to the print head nozzle surface and media, affecting print quality and causing failure of the print head.

- 1** From MENU on the touch panel, tap [SETTING 2].
- 2** Tap [Media] > [Head gap].
- 3** Enter the head gap value.
 - Setting value: 2.0 to 4.0 mm
- 4** Tap [SET].



Checking the Head Gap Value

- 1** From MENU on the touch panel, tap [SETTING 2].
- 2** Tap [Media].
 - The head gap value is displayed.

2.4 Test Printing

Print a test pattern to confirm that the ink prints correctly. Perform head cleaning if you observe any ejection failures (e.g., nozzle clogging or deflection).  ["Head Cleaning"](#)(P. 80)

Check beforehand

- Is media loaded?  ["Load the media."](#)(P. 62)
- Is the maintenance switch set to print mode?  ["Maintenance Switch"](#)(P. 37)
- Did you set the head gap?  ["Setting the Head Gap"](#)(P. 77)

Checking Print Head Discharge

1 From the MPC menu, tap [PRINT] > [TEST PATTERN] tab.

2 Tap [User] > [TestPattern] > [TestDraw Full-Size].

- A dialog box appears.
- Set the print origin as needed.
To change the print origin, refer to the operation manual [2.8 Printing] > "Setting Print Conditions".



- You can change the printing direction.  ["Printing Layout and Direction"](#)(P. 79)



3 Tap [Print].

- Test printing starts.

4 Check the print results.

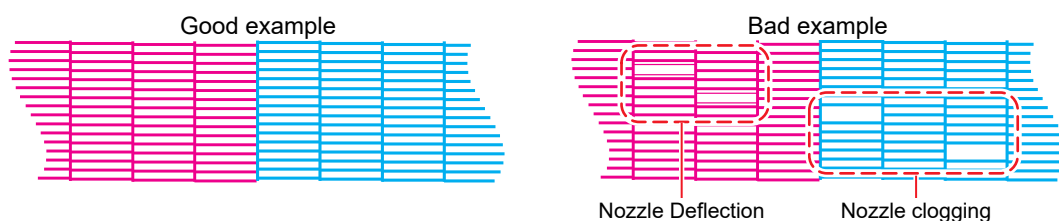

Printing Layout and Direction

You can change the printing layout and direction.

- 1 From MPC, tap [SETTING 1].
- 2 Tap [Internal pattern] > [Auto print origin shift].
 - A dialog box appears.

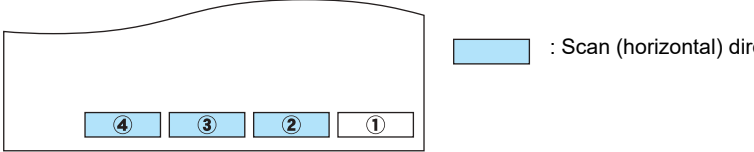
Internal pattern	Set the print position for printed patterns used in test printing or for correcting the drop position.
Origin shift	<ul style="list-style-type: none"> • Origin shift: Prints in the direction specified when set to ON. • Origin shift direction: Set the print direction. 
Origin shift margin	<ul style="list-style-type: none"> • Y margin: Sets the scan (horizontal) direction margin.

- 3 Tap [SET].

Ejection Failures

Typical examples of ejection failures (e.g., nozzle clogging, deflection) are as shown below. In order to prevent printing in such a state, check whether the ink has been properly ejected regularly before printing.

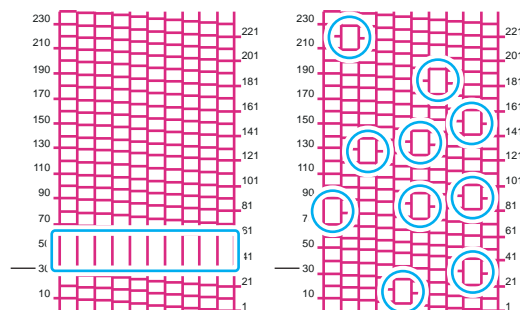
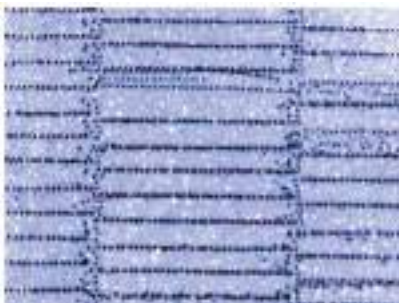

2.5 Head Cleaning

Cleaning

The following cleaning methods are available. Choose the method based on test results.

Item	Details
Soft	If the print shows a bent line (deflection)
Normal	If the print shows a missing line (nozzle clogging)
Hard	If soft cleaning and normal cleaning fail to resolve ejection failures (e.g., nozzle clogging or deflection).



- Cleaning is not possible when [Ink End] is displayed. Replace with new ink. ["Ink Tank Replacement Method"\(P. 52\)](#)

1 From MENU on the MPC, tap [MAINTENANCE].

- The Maintenance menu is displayed.

2 Tap [Cleaning] > [Cleaning].

- The Cleaning menu is displayed.



- The Cleaning menu can also be accessed by tapping [Cleaning] in the quick menu.

3 Select the type of cleaning and the head to be cleaned.

4 Tap [EXEC].

5 Run another test print and check the print results.

- Repeat the cleaning and test printing process until the print results appear normal.



- Do the following if head cleaning fails to resolve ejection failures such as nozzle clogging or deflection:
 - ["Wiper Cleaning"\(P. 132\)](#)
 - ["Powerful Cleaning"\(P. 80\)](#)
 - ["Cleaning the Print Head Nozzle Surface"\(P. 152\)](#)

Powerful Cleaning

Powerful cleaning is a function for helping to resolve ejection failures. It involves applying high pressure inside the sub-tank to eliminate all ink from inside the sub-tank, purging any air from inside the head, and then replacing the old ink inside the sub-tank with new ink.



- Powerful cleaning consumes approximately 130 cc of ink.

1 From MENU on the MPC, tap [MAINTENANCE].

- The Maintenance menu is displayed.

2 Tap [Cleaning] > [Powerful cleaning].

3 Select the head to be cleaned.



- Only one head unit can be selected for powerful cleaning. If you wish to perform powerful cleaning on multiple heads, repeat the procedure, changing the head selected.
-

4 Tap [EXEC].

2.6 Correcting the Drop Position

Changing the media and print head height will alter the drop positions during bi-directional printing. Correct the drop position to suit the type of media used. Image defects (e.g., overlaid lines or blurred images) will result if the drop position is not properly corrected.

Check beforehand

- Is media loaded? 🖨️ ["Load the media."\(P. 62\)](#)
- Is the maintenance switch set to print mode? 🖨️ ["Maintenance Switch"\(P. 37\)](#)
- Did you set the head gap? 🖨️ ["Setting the Head Gap"\(P. 77\)](#)



- Load media at least 500 mm wide. You cannot print the entire pattern if media less than 500 mm wide is used.

1 From MENU on the touch panel, tap [SETTING 2].

2 Tap [Bi-directional adjustment] > [**** **pattern].

- Select the resolution to adjust.



- The indicated resolutions are those in the scan direction.

3 Tap [EXEC].

4 Check the print results.

- A correction value input screen appears.
- Enter the position where the two upper and lower lines coincide.

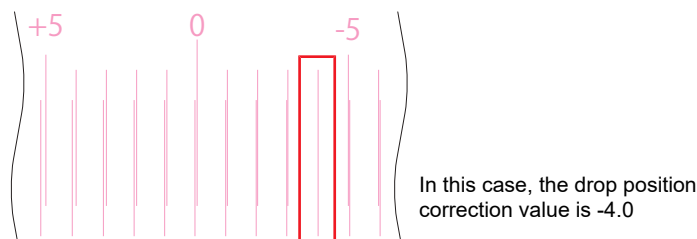

5 Tap [Bi-directional adjustment] > [Adjust Bi-directional print].

6 Enter the correction value.

- Correction value: -40 to 40

7 Tap [EXEC].



- If the lines do not coincide when the correction value is within the range -40 to 40, the head gap may be inappropriate. Adjust the gap. 🖨️ ["Setting the Head Gap"\(P. 77\)](#)

2.7 Preparing a Job (RIP Data)

The explanation here applies to MIMAKI RIP software (TxLink). The method for importing jobs (RIP data) into the machine (control PC) differs depending on the output port settings (☞ "Setting Up RIP Software"(P. 46)) in the TxLink printer settings.



- Prepare suitable image data for printing.
- Follow the procedure below to import jobs to the control PC for printing. Other methods (e.g., accessing the server from the control PC and printing jobs on the server) are not recommended because they may cause unexpected problems.

With Output Port Set to [MIMAKISTATUSPORT]

Import jobs (RIP data) to the machine (control PC) using a local network. ☞ "Connecting to a Local Network"(P. 39)

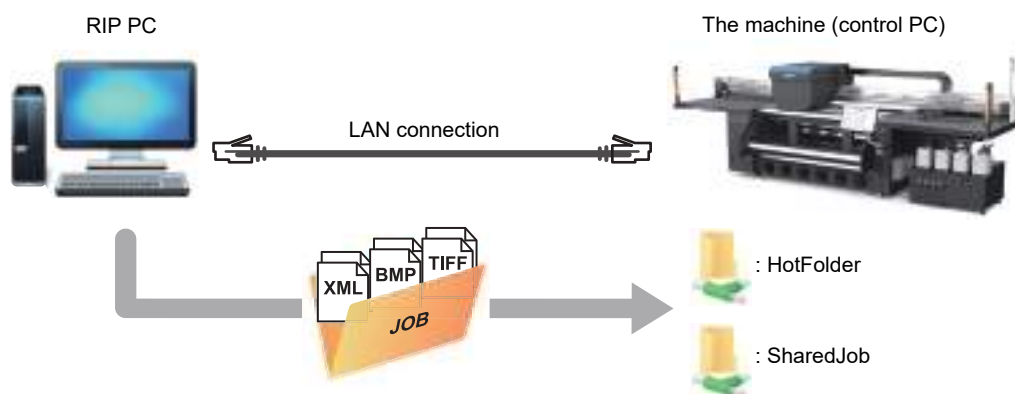

The shared folder for the machine (control PC) includes the following two types: These should be used as necessary, as the operation differs depending on the data saving destination.

Item	Overview
SharedJob	<ul style="list-style-type: none"> • Saving data in [SharedJob] adds the jobs to the MPC job list. ☞ "When saved to [SharedJob]"(P. 87) <ul style="list-style-type: none"> – Jobs can be printed by selecting from the job list.
HotFolder	<ul style="list-style-type: none"> • Saving data in [HotFolder] starts printing immediately. ☞ "When saved to [HotFolder]"(P. 87) <ul style="list-style-type: none"> – Printing is not always started immediately, even if you save to [HotFolder].

Creating RIP Data

1 Launch "TxLink".

2 Set the port type to [MIMAKISTATUSPORT].

- (1) Click the printer configuration button at the top of the window.



- (2) Click [SET].

- (3) Click [Print settings] > [Printer and port], then click the edit button.

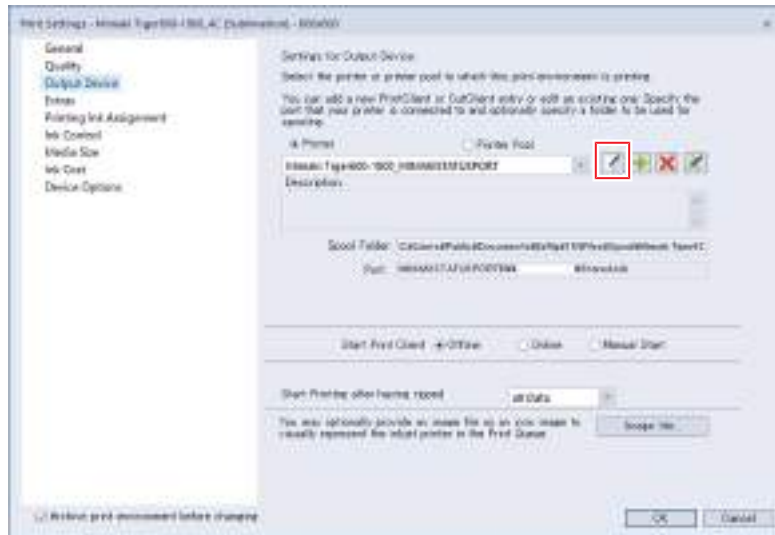

- (4) Select [MIMAKISTATUSPORT] for the port type, then click [OK].

The output shared folder can be selected from the following:

- SharedJob: To print from [JOB LIST] on the touch panel (Example: [*****\SharedJob])
- HotFolder: To print automatically (Example: [*****\HotFolder])



- Please change "*****" to the serial number of the printer.
- From MENU on the touch panel, tap [SYSTEM] > [System information] to display the serial number on the browser screen at right.

3 Select the image data to print.

- (1) Select [File] > [Open].

- (2) Select the desired image data, then click [Open].

4 Check the settings and alter as necessary.

- Configure the following print settings as required:
 - Properties on right of window

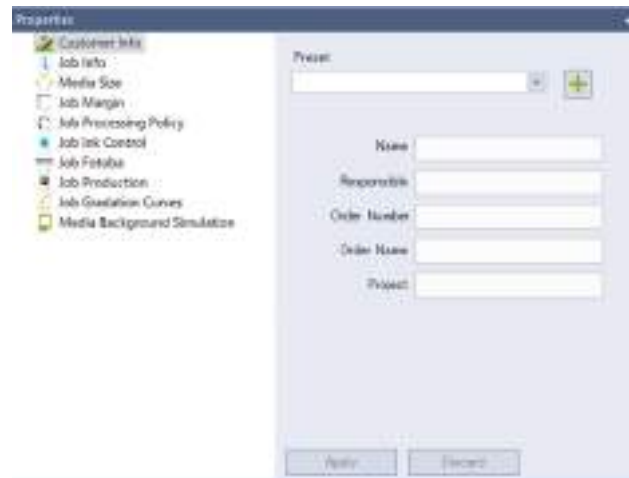

- [Print environment] > [Settings] at top of window

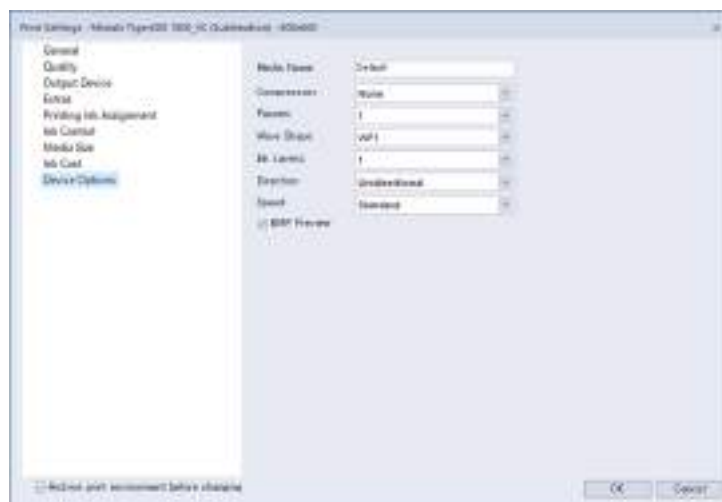

5 Prepare a job (RIP data) from image data.

- Clicking the [Print] button at the top of the window displays the print dialog.



- Set the name, then click [OK].

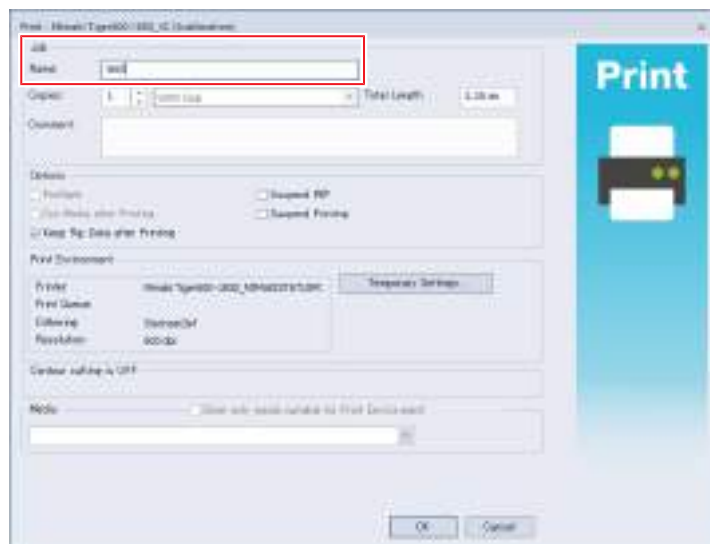

- Clicking the [Start print client] button at the top of the window displays the print client dialog. Click [Controller] > [Offline] at the top of the window to unselect the offline check box. The job output then starts automatically.

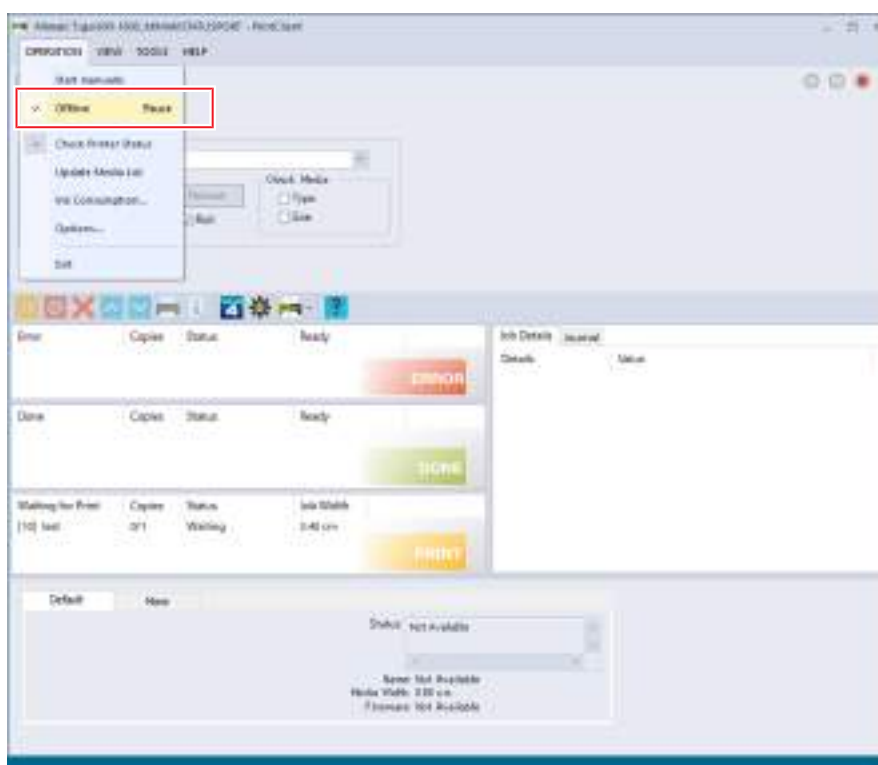

- When the output destination folder is [SharedJob]: The RIP job is added to the touch panel job list. ["When saved to \[SharedJob\]"\(P. 87\)](#)
- When the output destination folder is [HotFolder]: "Job receiving" is displayed in the lower-left corner of the touch panel screen, and printing starts. ["When saved to \[HotFolder\]"\(P. 87\)](#)



- When saving on the RIP PC, only the following ASCII characters can be used. Printing will not be possible if other characters are included.

File name and folder name supported characters list

	0	1	2	3	4	5	6	7	8	9	A	B	C	D	E	F
0																
1																
2	Space	!		#	\$	%	&	'	()		+	,	-	.	
3	0	1	2	3	4	5	6	7	8	9		;		=		
4	@	A	B	C	D	E	F	G	H	I	J	K	L	M	N	O
5	P	Q	R	S	T	U	V	W	X	Y	Z	[]	^	_
6	`	a	b	c	d	e	f	g	h	i	j	k	l	m	n	o
7	p	q	r	s	t	u	v	w	x	y	z	{		}	~	

When saved to [SharedJob]

Saving data in [SharedJob] adds the jobs to the MPC job list.

● Job checking procedure

Jobs that have been successfully loaded are saved in [SharedJob].

- From MENU on the touch panel, tap [PRINT] > [JOB LIST] > [SharedJob].

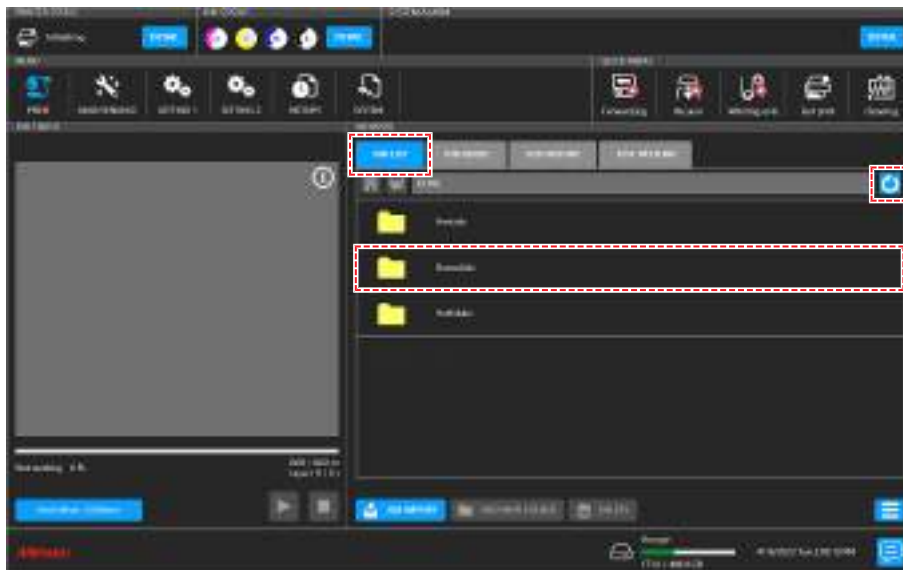

- If a job is not displayed, tap the refresh button.

When saved to [HotFolder]

Saving data in [HotFolder] starts printing immediately.

- If another job is currently being printed
 - The job is added to the queue. Printing starts automatically when the other job print is complete.

● Job checking procedure

Jobs that have been successfully loaded are saved to [HotFolder].

- From MENU on the touch panel, tap [PRINT] > [JOB LIST] > [HotFolder].

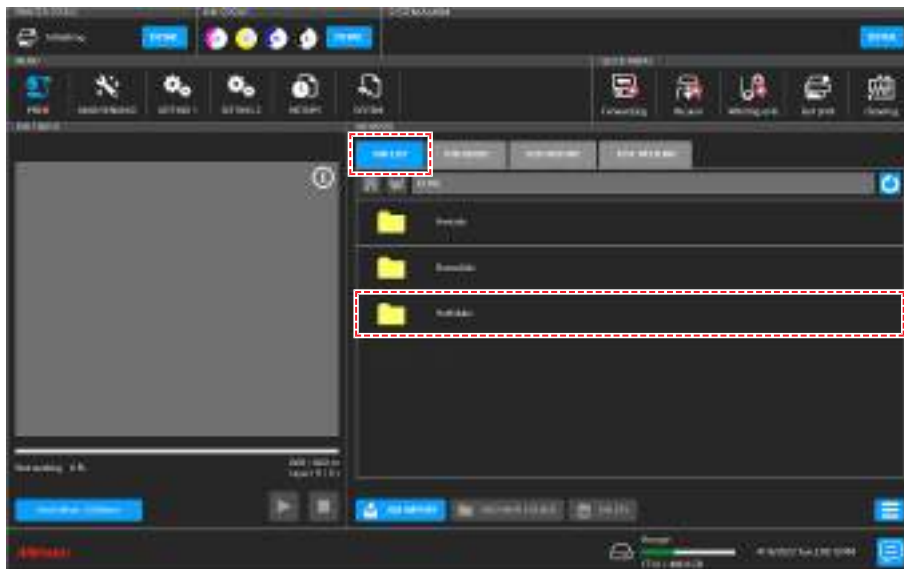

Copying jobs to a shared folder at any time

Jobs can be created in advance on the RIP PC, and then copied to the shared folder at any time for importing to MPC.

- 1 Create a job on the RIP PC in advance.**
- 2 Copy the job created on the RIP PC to the shared folder (SharedJob or HotFolder) to be used.**
 - Enter [*****] in the Explorer address bar to open the shared folder of the machine.

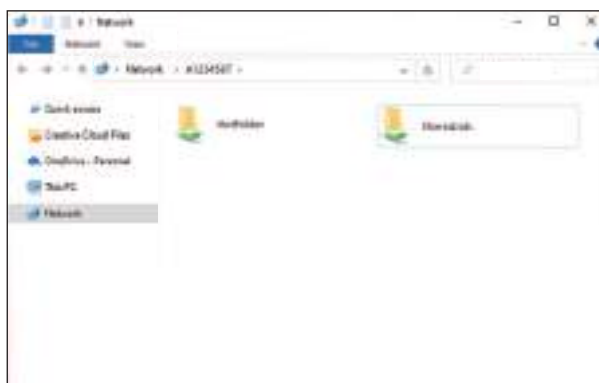

- Please change "*****" to the serial number of the printer.
- From MENU on the touch panel, tap [SYSTEM] > [System information] to display the serial number on the browser screen at right.

With Output Port Set to [File Interface]

Import jobs (RIP data) to the machine (control PC) using an external hard drive (e.g., USB flash memory).

Creating RIP Data

1 Launch "TxLink".

2 Set the port type to [File Interface].

- (1) Click the printer configuration button at the top of the window.



- (2) Click [SET].

- (3) Click [Print settings] > [Printer and port], then click the edit button.

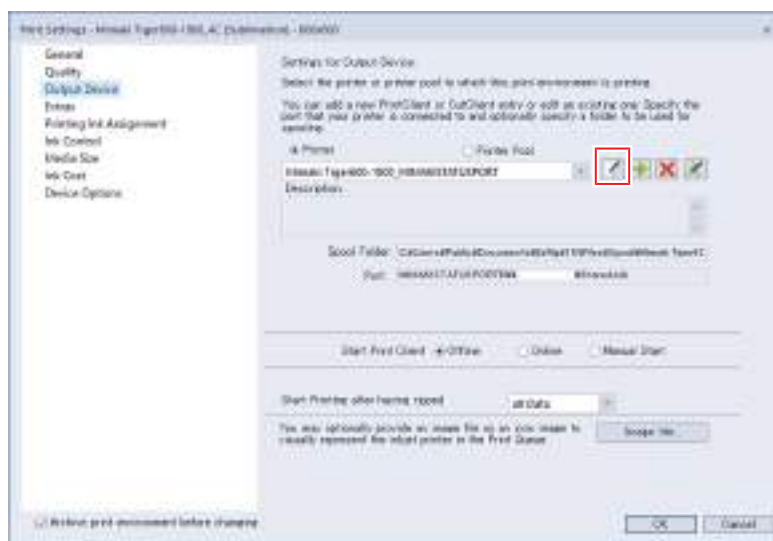

- (4) Select [File Interface] for the port type, then click [OK]

3 Select the image data to print.

- (1) Select [File] > [Open].

- (2) Select the desired image data, then click [Open].

4 Check the settings and alter as necessary.

- Configure the following print settings as required:
 - Properties on right of window

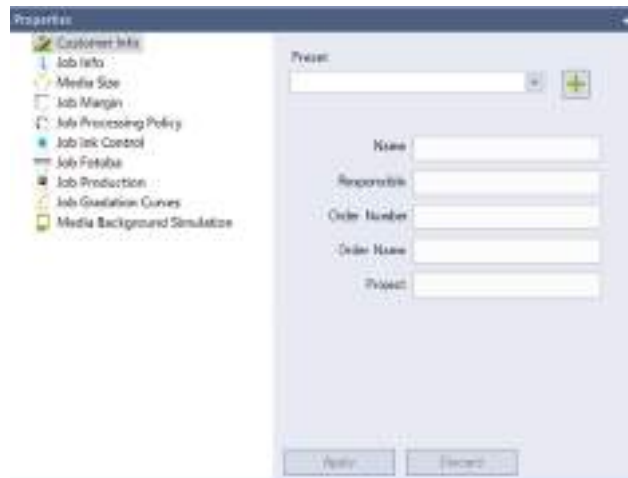

- [Print environment] > [Settings] at top of window

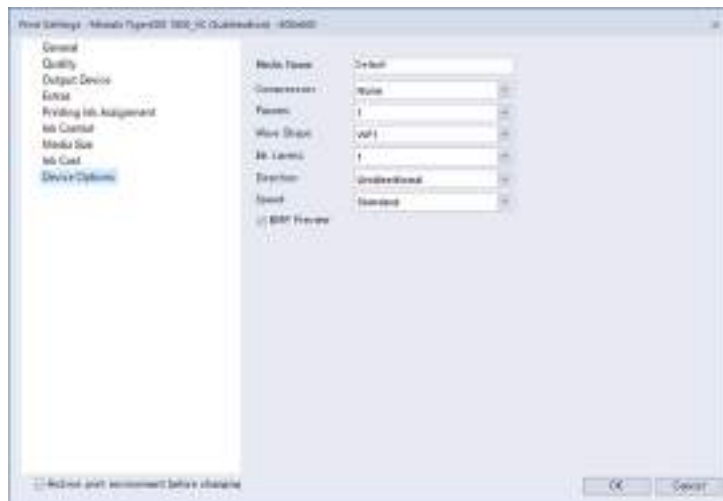

5 Prepare a job (RIP data) from image data.

- Clicking the [Print] button at the top of the window displays the print dialog.



- Set the name, then click [OK].

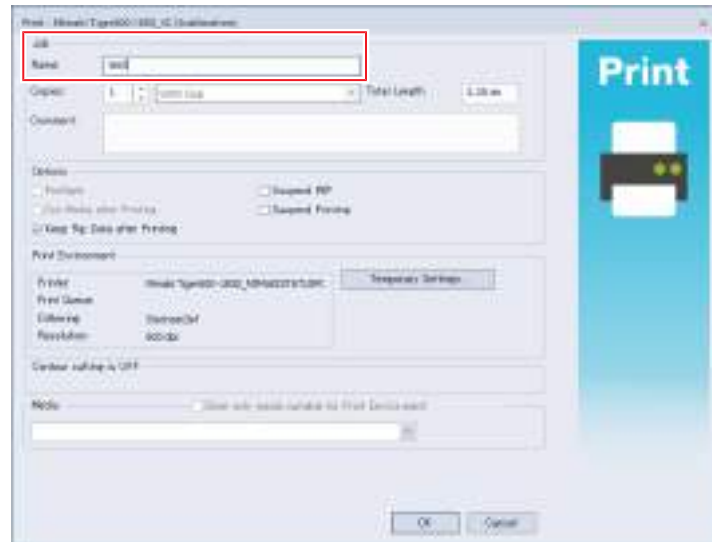

- Clicking the [Start print client] button at the top of the window displays the print client dialog. Click [Controller] > [Offline] at the top of the window to unselect the offline check box. The job output then starts automatically.

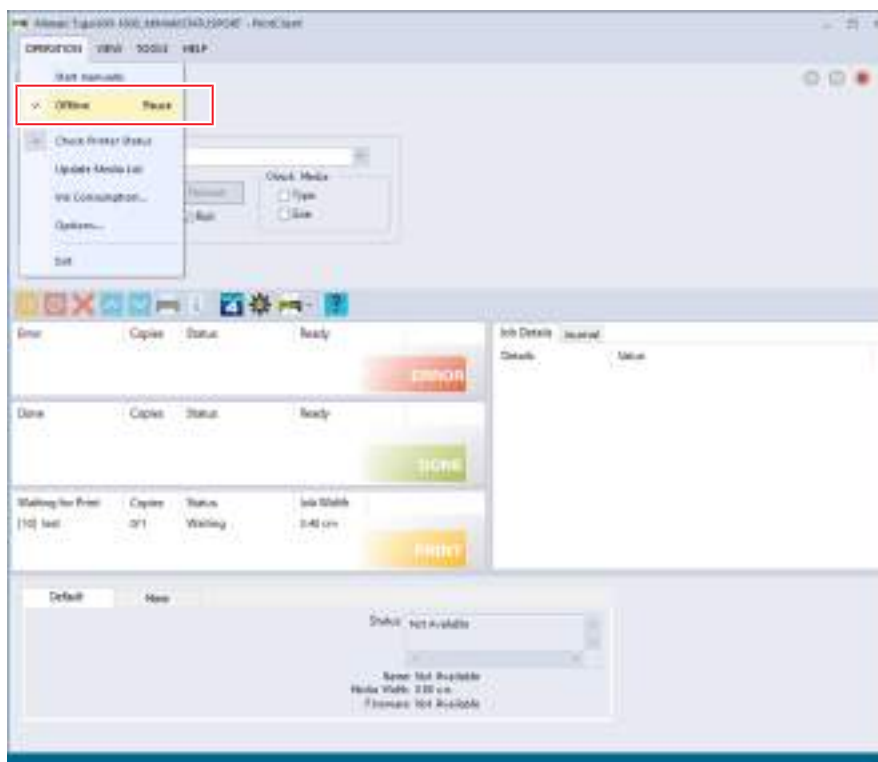

Saving to an External Hard Drive (e.g. USB Flash Drive)

- 1 Save the job (RIP data) stored on the RIP computer to an external hard drive.
 -  "Creating RIP Data"(P. 89)
- 2 Connect the external hard drive into the machine (control PC).
- 3 From MENU on the touch panel, tap [JOB IMPORT].



- A dialog box appears.
 - (1) Select the removable disk on which you will save the job.
 - (2) Specify where to save the job.
 - To add a folder, tap [ADD NEW FOLDER]. When the dialog box appears, enter a folder name to add the folder.



- (3) Select the job.
- (4) Tap [→] to import the job.

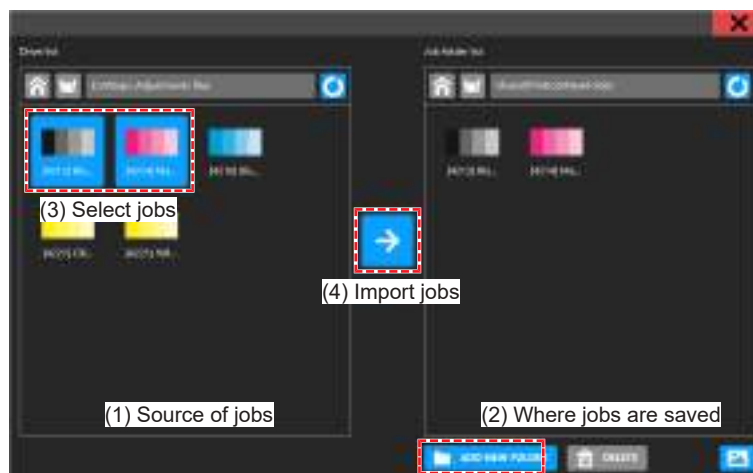

2.8 Printing

Check beforehand

- Is media loaded? 🖱️ ["Load the media."\(P. 62\)](#)
- Is the maintenance switch set to print mode? 🖱️ ["Maintenance Switch"\(P. 37\)](#)
- Did you set the head gap? 🖱️ ["Setting the Head Gap"\(P. 77\)](#)

Starting Printing

1 Tap [JOB LIST] and select the job to print.

- A dialog box appears.

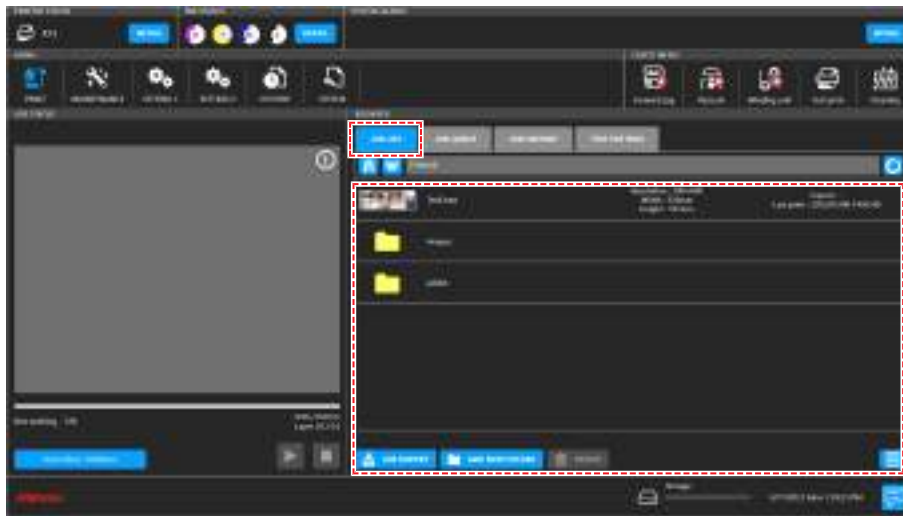

- Print speeds may differ for the same image data, depending on the width of the medium loaded, print origin position, and resolution.
- Any errors will prevent further printing.



- Please turn on the heater during printing to avoid winding failure. 🖱️ ["Setting 1 Menu"\(P. 118\)](#)
- If you wish to delete a job, tap and hold (long tap) on the job and then tap [Delete]. Jobs deleted any other way will remain listed in [JOB LIST].

2 Set the print conditions.

- 🖱️ ["Setting Print Conditions"\(P. 94\)](#)

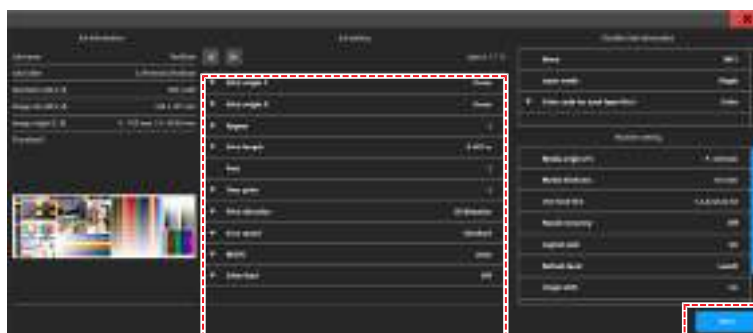

3 Tap [Print].



- Printing starts once the machine receives the job. Check printing progress in the print status area.  ["Mimaki Printer Controller"\(P. 100\)](#)



- Print speeds may differ for the same image data, depending on the width of the medium loaded, print origin position, and resolution.
- Any errors will prevent further printing.

Setting Print Conditions



No.	Name	Overview
1	Job Information	Check the job information as needed.
2	Detailed Job Information	Check the job details as needed.
3	Machine setting	Check the machine settings information as needed.
4	Print origin Y	Enter the print origin in the scan (horizontal) direction.  "Print Origin"(P. 95)
	Print origin X	Enter the print origin in the feed (vertical) direction.  "Print Origin"(P. 95)
	Repeat	Prints after feeding for the set amount.
	Print Length	Sets the print length.
	Pass	Set the path. The path selected by the RIP software is displayed as " RIP selected pass ". If a path lower than the RIP selected pass is selected, drying defects may occur.
	Over print	Set the number of layers in overprinting.
	Print direction	Set to print unidirectionally or bidirectionally.
	Scan speed	Set the carriage scanning speed.
	MAPS	Set whether to use Auto or Presets 1 to 3 ( "Setting 1 Menu"(P. 118)). Selecting manual enables individual settings for each job.
	After feed	Sets the feed position and distance after printing.

Print Origin

The print start position can be altered.

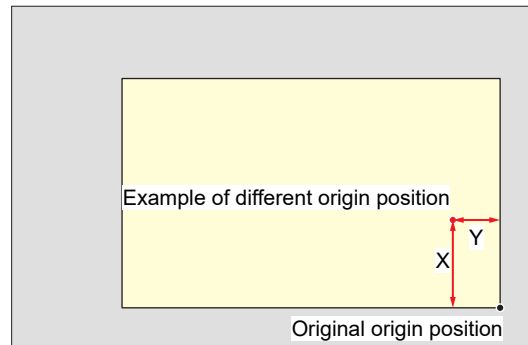

Pausing Printing

1 While printing is in progress, tap [Pause].

- Printing pauses.

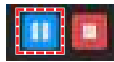

- Some functions are not available while printing is paused.

2 Tap [Resume].

- Printing resumes.

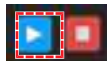

Stopping Printing

1 Tap [Stop] to cancel printing.



- After cancellation, the carriage returns to the station.
- Any subsequent jobs are displayed in the print status area. To resume printing, tap [Resume].

Skipping the wait until heater temperature is reached

1 Tap [Skip] while waiting for the heater temperature to reach the specified level for printing.

- Printing starts immediately, without waiting to reach the heater temperature.



- This may affect the print finish.

Printing Using Nozzle Recovery

Nozzle recovery is a function that is useful when nozzle clogging cannot be resolved for specific nozzles. When nozzle recovery is enabled, if a nozzle is determined to be clogged in the nozzle check, normal nozzles are used supplementarily during printing.

Enabling Nozzle Recovery Function

● Enabling nozzle recovery

1 From MENU on the MPC, tap [MAINTENANCE].

- The Maintenance menu is displayed.

2 Tap [Nozzle Recovery] > [Nozzle Recovery].

- A dialog box appears.

3 Tap [Mode] to enable it.

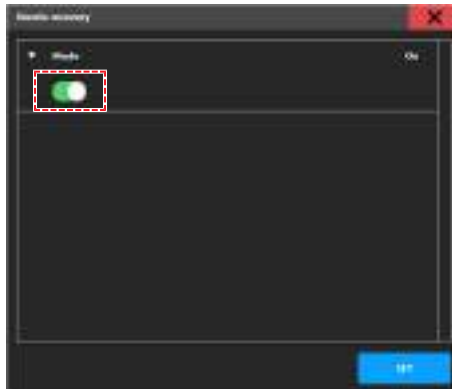

4 Tap [SET].



- Using this function does not change the time required for printing.
- If the print conditions are set to the minimum number of passes in the RIP software, the nozzle recovery function will be disabled.
- Even when nozzle recovery has been registered and enabled, recovery will not be applied to print patterns such as test printing and dot position correction.

● Checking nozzle recovery settings

1 Check the Nozzle recovery setting ("On" or "Off") in "Machine setting" on the print conditions screen.



- 2 Check the nozzle recovery setting ("Off", "Disabled", or "Enabled") for the job being printed on the JOB STATUS check screen after starting printing.

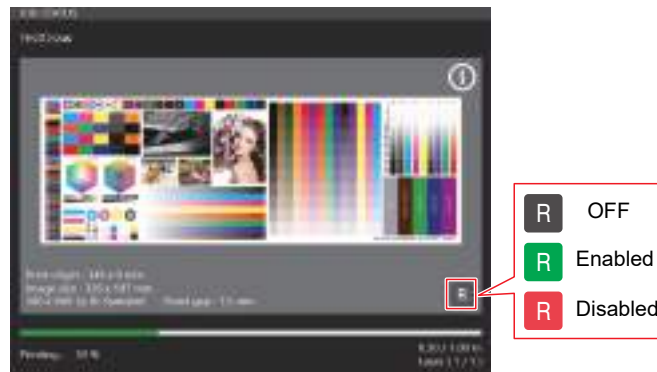



- ✓ A confirmation message is displayed before the start of printing to continue with nozzle recovery when certain conditions apply. There are three different patterns for the confirmation messages, as follows:

- (1) For print conditions in which nozzle recovery does not apply
 → Displayed when printing will be performed in high-performance mode.
 Change the following settings to enable nozzle recovery:
- Increase the number of passes
 - Reduce the MAPS speed
 - Change the scan speed from "High" to "Normal"



- (2) When nozzles exist that cannot be recovered using nozzle recovery (Case 1)
 → Printing is possible by reducing the print speed to enable nozzle recovery. Select [Apply settings and continue print] on the message window.



- (3) When nozzles exist that cannot be recovered using nozzle recovery (Case 2)
 → Displayed in the case of print conditions for which nozzle recovery cannot be applied even by reducing the print speed.
 Change the following settings to enable nozzle recovery:
- Increase the number of passes
 - Reduce the MAPS speed
 - Change the scan speed from "High" to "Normal"



Chapter 3 Settings (MPC)



This chapter

This chapter describes various functions of the MPC (Mimaki Printer Controller).

Mimaki Printer Controller	100	Setting 1 Menu	118
Screen structure	100	Setting 2 Menu	120
Print menu	104	Function of Brake	120
Maintenance Menu	105	History Menu	125
Registering abnormal nozzle with the nozzle check tool	106	System menu	126
Regist nozzle recovery	115	Power Supply	127







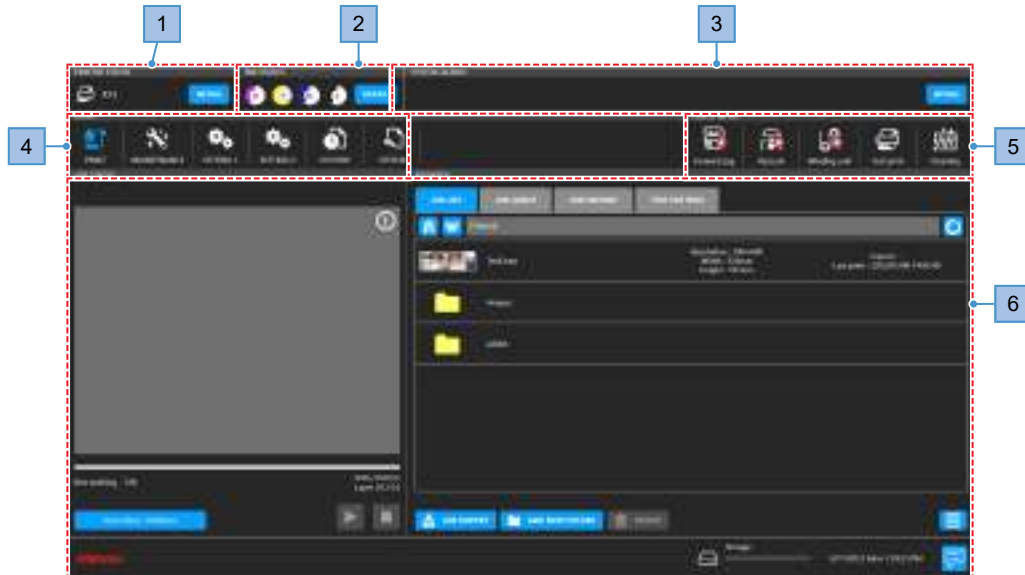







3.1 Mimaki Printer Controller

MPC software is used to operate and control the Tiger600 series. The Mimaki Printer Controller is installed on the control PC. The touch panel is used for MPC operations.

Screen structure



No.	Item	Overview
1	PRINTER STATUS (printer information area)	Machine status is indicated by icons. "PRINTER STATUS"(P. 101) <ul style="list-style-type: none"> DETAIL: Displays the status of each component of the configuration.
2	INK STATUS (ink information area)	Icons indicate remaining ink levels, ink errors, and other Ink tank status information. "INK STATUS"(P. 102) <ul style="list-style-type: none"> DETAIL: Displays the Ink tank slot number and ink color.
3	SYSTEM ALARM (system information area)	Of various possible errors, this area shows the most important errors. "SYSTEM ALARM"(P. 102) <ul style="list-style-type: none"> DETAIL: Displays all current errors.
4	MENU (menu area)	Shows various menus. The "*" marks displayed in the various menus indicate default values. <ul style="list-style-type: none"> (PRINT): Set print conditions/settings for the media used. "Print menu"(P. 104) (MAINTENANCE): Menu used for machine maintenance "Maintenance Menu"(P. 105) (SETTING 1): Used to set various printing-related operations "Setting 1 Menu"(P. 118) (SETTING 2): Used to set various operations for the machine "Setting 2 Menu"(P. 120) (HISTORY): Shows maintenance records and other information. "History Menu"(P. 125)







No.	Item	Overview
		<ul style="list-style-type: none">  (SYSTEM): Shows various information about the machine.  "System menu"(P. 126)
5	QUICK MENU (quick menu area)	<p>Shows frequently used menus.</p> <ul style="list-style-type: none">  (Feed): Feeds the media.  (Vacuum): Applies suction to hold media in place. Load the media.  (Tension bar): Initializes the tension bar.  (Test print): Prints a test pattern to confirm that the ink prints correctly.  "Test Printing"(P. 78)  (Cleaning): Clean the heads in case of ejection failures (e.g., nozzle clogging, deflection).  "Head Cleaning"(P. 80) This is displayed only when [Setting 1] > [Drying heater] is enabled.  "Setting 1 Menu"(P. 118)  (Heater error): An error has occurred in the drying heater. The drying heater will not operate even when the button is pressed.  (Heater stopped): The heater has stopped and is not turned on. Pressing the button starts heating the heater until the preset temperature is reached.  (Heater on): The drying heater is warming up to the preset temperature. Pressing the button stops the heater.  (Heater standby): The drying heater is at standby after warming up to the preset temperature. Pressing the button stops the heater.
6	(Content area)	Shows setting screens for the selected menu.

PRINTER STATUS





Icons indicate the machine status. Tap [Detail] to display the status of each component of the configuration.



● Icon display

Icon	Overview
	Local mode. Used for test printing, maintenance, and settings
	Printing in progress.
	Printing is paused.
	Maintenance is in progress. No other operations can be performed while maintenance is underway.
	An obstruction has been detected. Printing pauses.
	Set the maintenance switch to maintenance mode.

● Detail display



Display details	Overview
	Displays the device operation status.
	Displays the timing for auto cleaning and auto flushing.
	Displays the drying heater temperature. This is displayed only when [Setting 1] > [Drying heater] is enabled.  "Setting 1 Menu"(P. 118)

INK STATUS

Icons indicate remaining ink levels, ink errors, and other Ink tank status information. Tap [Detail] to display the slot number and ink color.



● Icon display

Icon	Overview
	Remaining ink levels are indicated graphically and as percentages.
	A blue warning icon appears in the lower right if ink runs low. Very little ink remains. Have new ink ready.
	A yellow warning icon appears in the lower right if ink runs out or ink errors occur. Printing is not possible.



SYSTEM ALARM



Of various possible errors, this area shows the most important errors. Tap [Detail] to display all current errors.

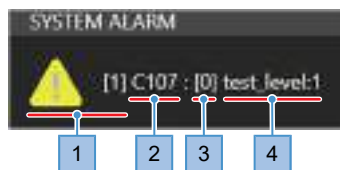

● Alarm display



No.	Overview	
1	Level	 (Level 0): Printing is possible. Printing will continue even if these errors occur during printing. <ul style="list-style-type: none"> Examples: Ink near-end, tank cap not fitted
		 (Level 1): Printing and cleaning is not possible. Any printing underway will pause if any of these errors occur. Take appropriate measures based on the message. <ul style="list-style-type: none"> Examples: Ink end
		 (Level 2): Printing and cleaning is not possible. Any printing underway is aborted if any of these errors occur. Take appropriate measures based on the message.

No.	Overview	
		<ul style="list-style-type: none"> Examples: Ink overflow
		 (Level 3): No machine operations are possible. Take appropriate measures based on the message. If you see this message repeatedly, contact your local dealer or our service office.
2	Code	Refer to the error code list.  "Problems Indicated by Messages"(P. 154)
3	Unit	Not disclosed; used for service
4	Contents	Refer to the error code list.  "Problems Indicated by Messages"(P. 154)

Clearing Alarms

1 Tap [DETAIL].

- Displays all current errors.



2 Resolve the cause of the error.

-  ["Problems Indicated by Messages"\(P. 154\)](#)

3 Tap [CLEAR ALARM].

- This clears the error.











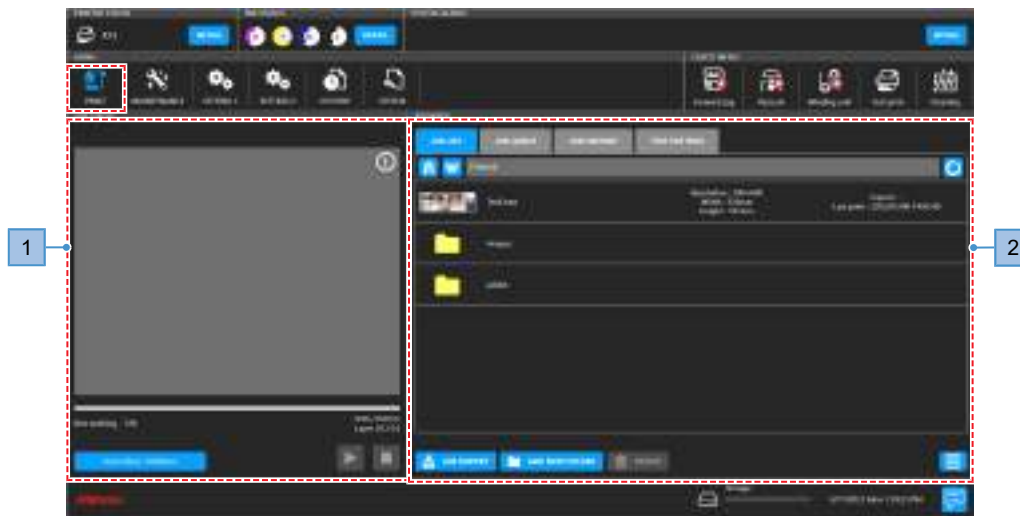



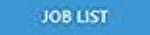
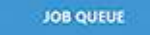

Important!

- If this does not clear the error/alarm, your response may be incorrect or inadequate. Check the alarm details once again and take corrective action. If this alarm recurs, contact your local dealer or our service office.

3.2 Print menu

Set print conditions/settings for the media used.







No.	Item	Overview
1	Job status area	<p>Displays a job thumbnail and print status.</p> <ul style="list-style-type: none"> : Pause the job currently being printed. : Resume printing. : Cancel printing.
2	Browser area	<p>List print jobs. Tap a job to display a dialog box for setting print conditions/settings.  "Setting Print Conditions"(P. 94)</p> <ul style="list-style-type: none"> : Show the jobs stored on the control PC. : Show queued jobs. Numbers in the upper right of the icon indicate the number of queued jobs. : Show printed jobs. Tap on a job to print it. : Show jobs used for test patterns. : Show the home folder. : Show the folder one level above. : Update the folder display. : Import the job into MPC.  "With Output Port Set to [File Interface]"(P. 89) : Create a new folder. A dialog box appears. : Delete the job or folder that was selected with a long tap. Jobs deleted any other way will remain listed in [JOB LIST]. : Lets you sort or otherwise change how the job list is displayed.

3.3 Maintenance Menu

This menu is used for machine maintenance.



Item	Overview
Cleaning	Print a test pattern to clean the heads in case of ejection failures (e.g., nozzle clogging, deflection). "Head Cleaning"(P. 80)
Cleaning	Three types of cleaning are available. Choose the method based on test results.
Powerful Cleaning	Use when problems are not resolved by regular cleaning.
Auto Maint.	Set the conditions to start print head cleaning automatically.
Cleaning (Standby)	<ul style="list-style-type: none"> • Cleaning (Standby): When this is turned on, head cleaning will be performed once the [Interval (Time)] has elapsed. Set to OFF if you prefer not to clean automatically. • Interval (time): Cleans heads after the specified value is exceeded. • Mode: Set type of cleaning.
Cleaning (Print)	<ul style="list-style-type: none"> • Cleaning (Print): When this is turned on, head cleaning will be performed during printing once the [Interval (Time)] has elapsed. Set to OFF if you prefer not to clean automatically. • Interval (Time): Cleans heads during printing after the specified value is exceeded. • Mode: Set type of cleaning.
Flushing (Standby)	<ul style="list-style-type: none"> • Flushing (Standby): Set to ON for flushing. Flushing reduces nozzle clogging via regular print head ink discharge. • Interval (time): Flushes heads after the specified value is exceeded.
Nozzle Recovery	Allows other nozzles to be used for printing if nozzle washing or other maintenance fails to resolve ejection failure (such as nozzle clogging or deflection).
Nozzle Recovery	Performs nozzle recovery automatically if nozzle clogging is detected. <ul style="list-style-type: none"> • Mode: Set to ON for automatic nozzle recovery.
Nozzle recovery confirmation message	If nozzle recovery cannot be performed, setting [Nozzle Recovery Confirmation Message] to OFF will start printing without displaying the print continuation confirmation dialog box.
Nozzle recovery operation guide	Shows the nozzle recovery operation guide.
Scanner	Starts the scanner application.
Nozzle check tool	Starts the nozzle check tool. Allows nozzles with abnormalities to be registered.
Regist nozzle recovery	Displays the results of the currently registered nozzle check. It also allows manual registration and clearing of abnormal nozzles.
Daily maintenance	Lists items for which daily maintenance should be performed.
Daily station maintenance	Moves the carriage for cleaning around the station. "Wiper Cleaning"(P. 132) "Wiper Unit Cleaning"(P. 135)

Item	Overview
Head maintenance	Moves the carriage to the maintenance space for cleaning in the print head area.  "Carriage Underside Cleaning"(P. 134)
Weekly maintenance	Lists items for which weekly maintenance should be performed.
Weekly station maintenance	Moves the carriage for cleaning around the station.  "Wiper Unit Cleaning"(P. 135)
Other maintenance	Lists maintenance items to inspect in the event of errors.
Ink tank calibration	Runs the ink tank calibration wizard.
Purified water tank calibration	Runs the purified water tank calibration wizard.
Drying unit Taking out	Runs the drying unit taking out wizard.
Moisture tray maintenance	Runs the moisture tray maintenance wizard.  "Moisture Tray Cleaning"(P. 136)
Replace parts	Displays replacement instructions for components requiring periodic replacement.
Replace ink filter	Executes the ink filter replacement wizard. The machine requires ink filter replacement about once a year, but sooner replacement may be required depending on operating conditions. If a 061B INK SUPPLY error occurs, the filter may be clogged. Run the wizard to replace it as described. If a 067D INK SUPPLY WARN warning occurs, the filter may be beginning to clog. Replacing the ink filter as soon as possible is recommended.
Replace wiper	The machine maintains a count of the number of wiping cycles. Once the specified value is reached, "0605 REPLACE WIPER" will appear in SYSTEM ALARM on the touch panel. Replace dirty or warped wipers with new ones.  "Wiper Replacement"(P. 143)

Registering abnormal nozzle with the nozzle check tool

Abnormal nozzle locations can be registered by using the nozzle check tool with printed image data from a nozzle recovery pattern.

Printing nozzle recovery patterns

Print a nozzle recovery pattern as follows. Patterns are printed at about A4 size.



- As the media, use transfer paper.

- 1 From the MPC menu, tap [PRINT] > [TEST PATTERN].

- 2 Tap [User] > [NozzleCheck], then tap the nozzle recovery pattern.



- 3 Tap [Print] to print the pattern on the media.



Scanning nozzle recovery patterns

Cut out and scan the printed nozzle recovery pattern.

- 1 Cut the printed nozzle recovery pattern along the cut lines.



2 From the MPC menu, tap [MAINTENANCE] > [Nozzle recovery] > [Scanner].

- The scanner application starts up.

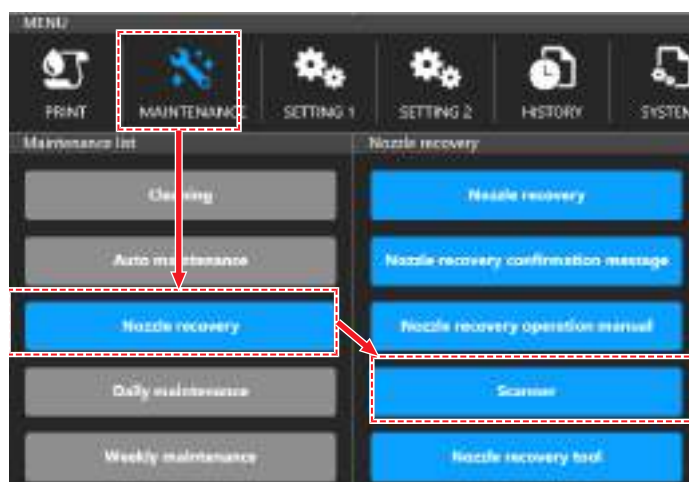

3 Tap [Scan settings].

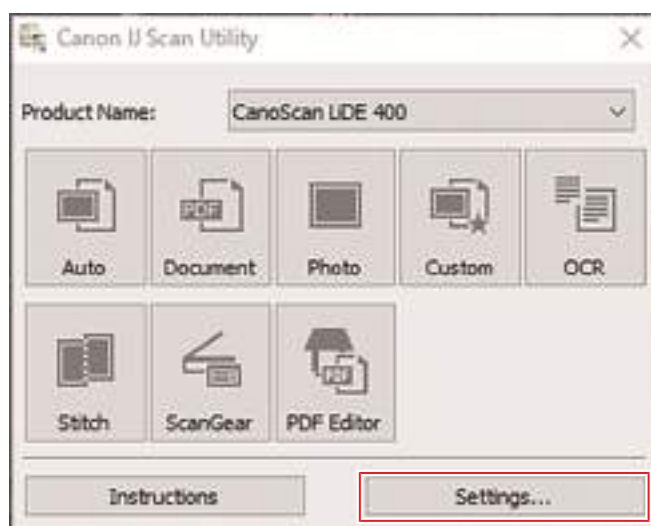

4 On the scan settings screen, select [ScanGear]. Configure the settings as follows, then select [OK].

- [Data Format]: png
- Select the [Enable large image scans] check box.

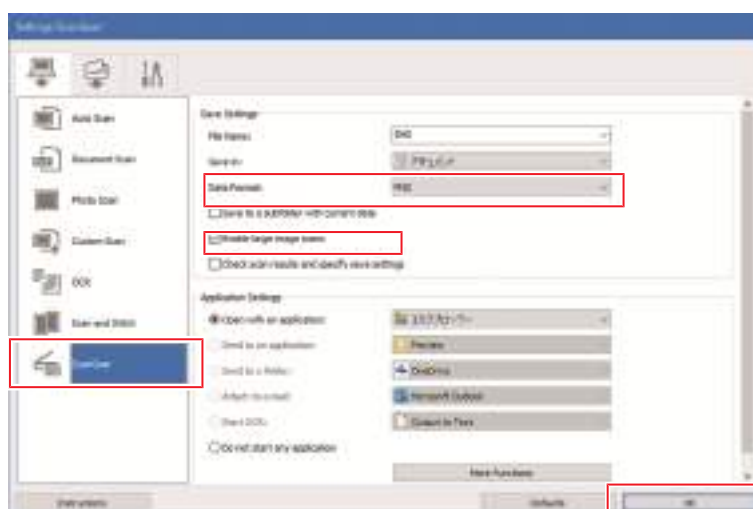

5 Place the printed nozzle recovery pattern face-down on the scanner and close the cover.

- On the scanner, align the top of the black triangle in the pattern with the arrow mark of the scanner that indicates the starting point.

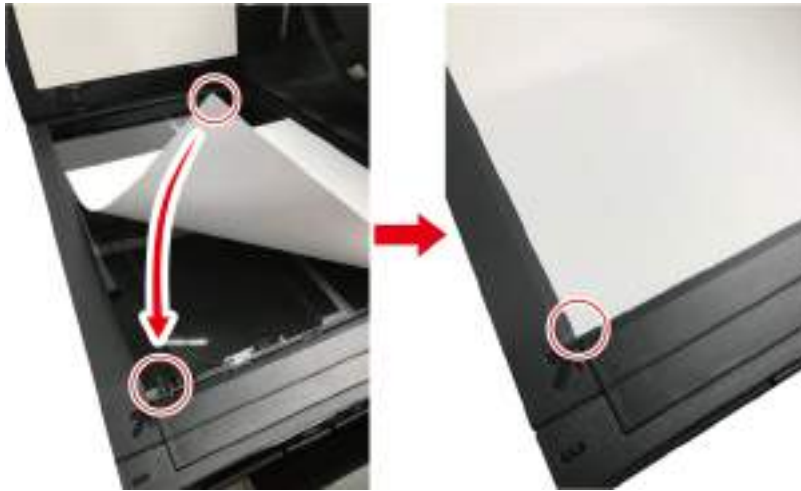
**6** Open the scanner application and select [ScanGear].

- A dialog box appears.

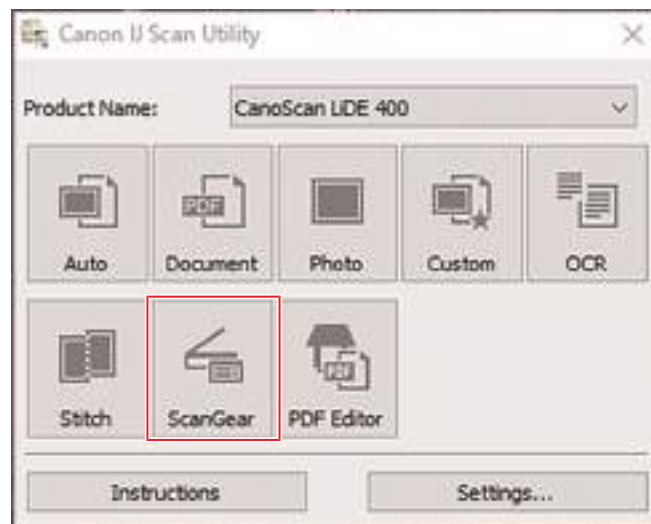

7 Select the [Extended Mode] tab, configure the settings as follows, then select [Scan].

- [Document Type]: Paper/Photo
- [Output Resolution]: 2400
- [Edge Enhancement]: OFF



Analyzing and applying nozzle recovery patterns

The scanned nozzle recovery pattern is analyzed by the nozzle check tool and analysis results are applied to the printer.

1 From the MPC menu, tap [MAINTENANCE] > [Nozzle recovery] > [Nozzle check tool].

- The nozzle check tool starts up.

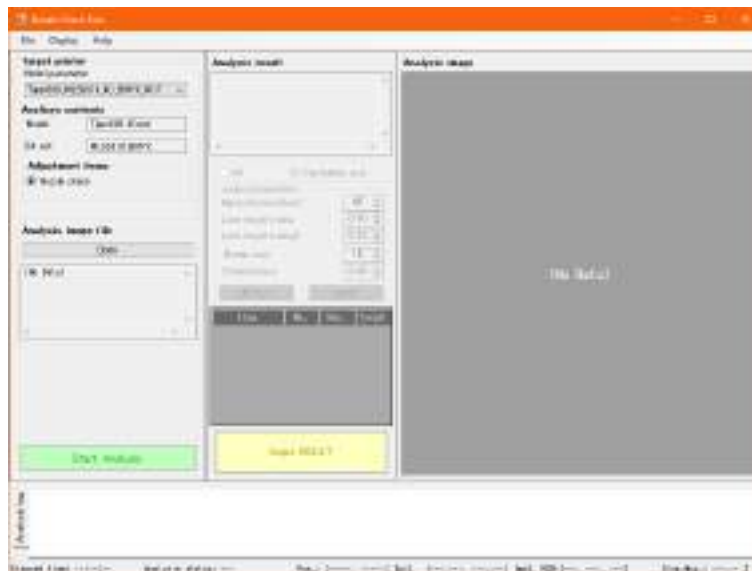

2 Configure nozzle check tool settings.

- In [Model parameter], select the model, type of ink, and ink set.
- In [Analysis contents], confirm that the model, type of ink, and ink set are correctly selected.

Target printer

Model parameter
Tiger600_MLSb510_4C_BMYK_NCT

Analysis contents

Model: Tiger600 4Color

Ink set: MLSb510 BMYK

Adjustment items

Nozzle check

3 In [Analyze image file], tap [Open] and select the scanned image data.

- The image data is displayed in [Analysis image].

Analysis image file

Open

(No Data)

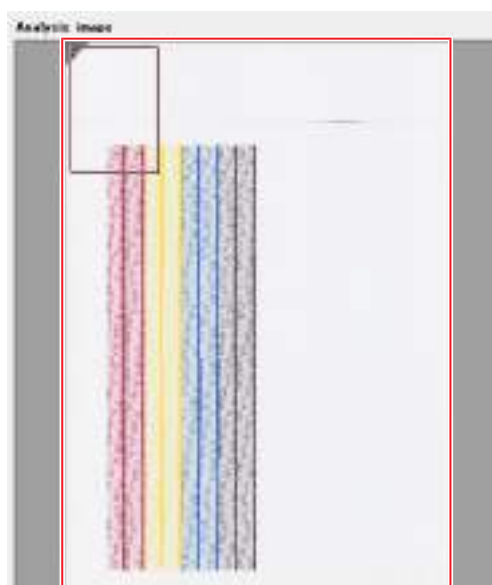

4 Tap [Start Analysis].

- The image data is analyzed and the analysis results are displayed in [Analysis result].

Start Analysis

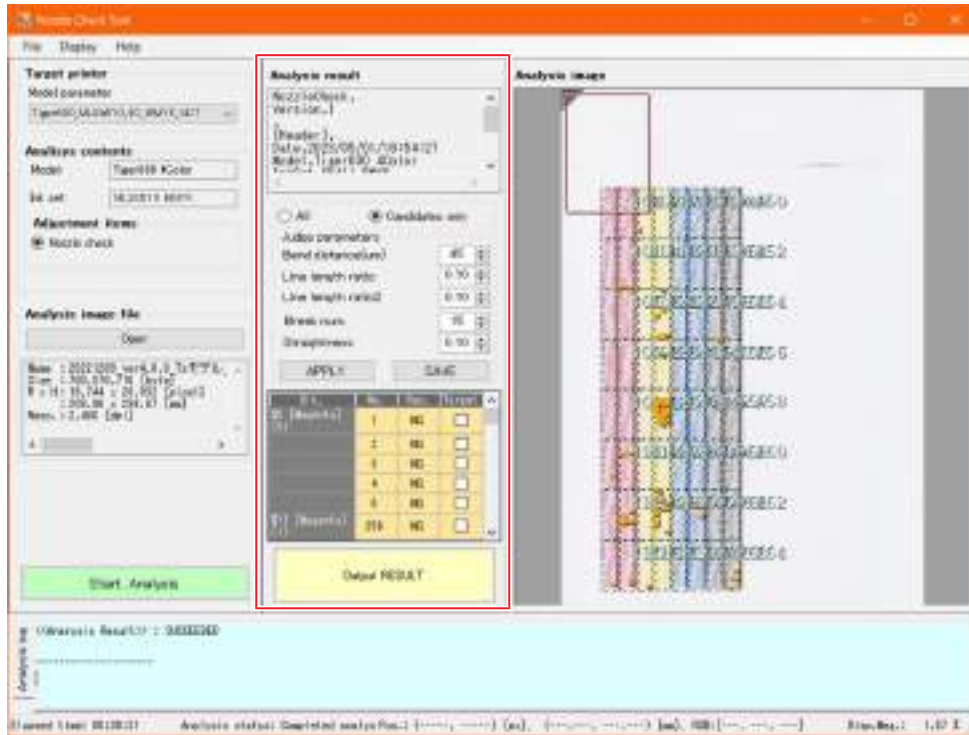

5 Configure nozzles for nozzle recovery.

(1) Tap [Candidates only].

- Only nozzles that are candidates for nozzle recovery are shown in the data display area.



(2) For nozzles targeted for recovery, click the [Target] check box.

- Nozzles set for recovery are indicated by a red cell background color.

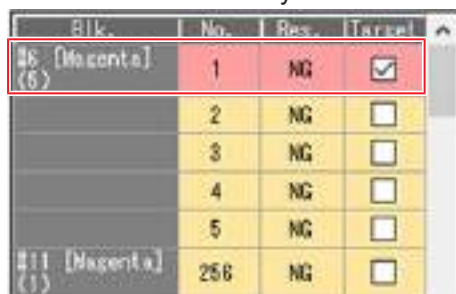

6 Tap [Output RESULT].

- The settings are saved and applied to the printer.

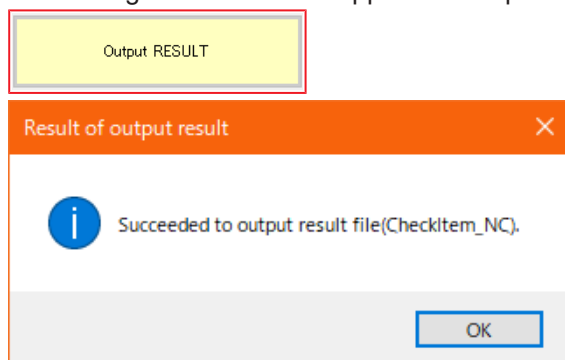

Important!

- In case of errors, refer to the operation manual for the nozzle check tool.
- Access the operation manual as follows.
 - Start the nozzle check tool.
 - Tap [Help] > [Show manual].

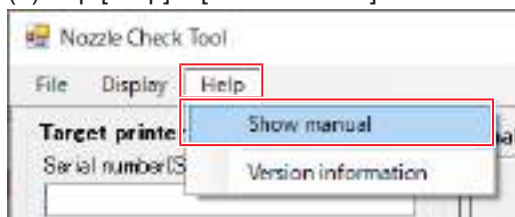

Regist nozzle recovery

Nozzle Recovery Registration Dialog

Displays the results of the currently registered nozzle check. It also allows you to manually register and clear abnormal nozzles.

1 From MENU on the touch panel, tap [MAINTENANCE].

- The Maintenance menu is displayed.

2 Tap [Nozzle recovery] > [Regist nozzle recovery].

- A dialog box appears.

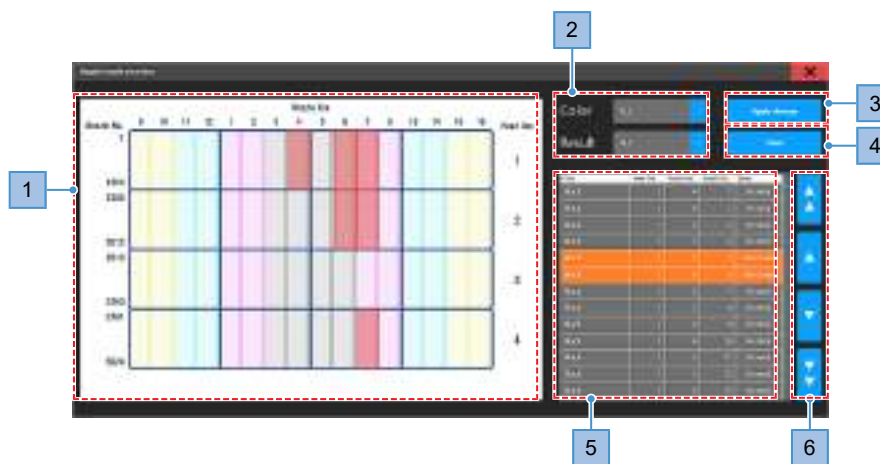

No.	Name	Overview
1	Nozzle illustration	Displays an illustration corresponding to the nozzle recovery table. <ul style="list-style-type: none"> If a nozzle is clogged, the corresponding area will flash red.
2	Nozzle recovery table filter	You can specify conditions to narrow down the contents of the nozzle illustration and nozzle recovery table. <ul style="list-style-type: none"> [Color]: Narrows down the nozzles by ink color. ALL displays all ink colors and nozzles. [Result]: Narrows down the nozzles by the result of the nozzle check. "Abnormal" displays only clogged nozzles. ALL displays all results.
3	Apply change	Applies changes to the nozzle recovery registration.
4	Clear	Clears changes applied to the nozzle recovery registration.
5	Nozzle recovery table	Displays the status of each nozzle by color. <ul style="list-style-type: none"> Nozzles with abnormalities are displayed with an orange background. Head line: Head row (Horizontal axis direction in the nozzle status illustration) Nozzle line: Nozzle row (Vertical axis direction in the nozzle status illustration) Nozzle No.: Nozzle number for each ink color Status: Result of nozzle check (normal/abnormal)
6	Scroll buttons	Scroll through the nozzle recovery table. <ul style="list-style-type: none"> : Move 1,000 nozzles in the direction of the arrow. : Move 100 nozzles in the direction of the arrow.

Printing a Nozzle Check Pattern for Registration

To print a nozzle check pattern and manually perform nozzle recovery registration, follow the steps below.

- 1 From MENU on the touch panel, tap [PRINT].
- 2 Tap [TEST PATTERN] > [User] > [NozzleCheck] and tap the job of the color for which the nozzle recovery registration is to be made.

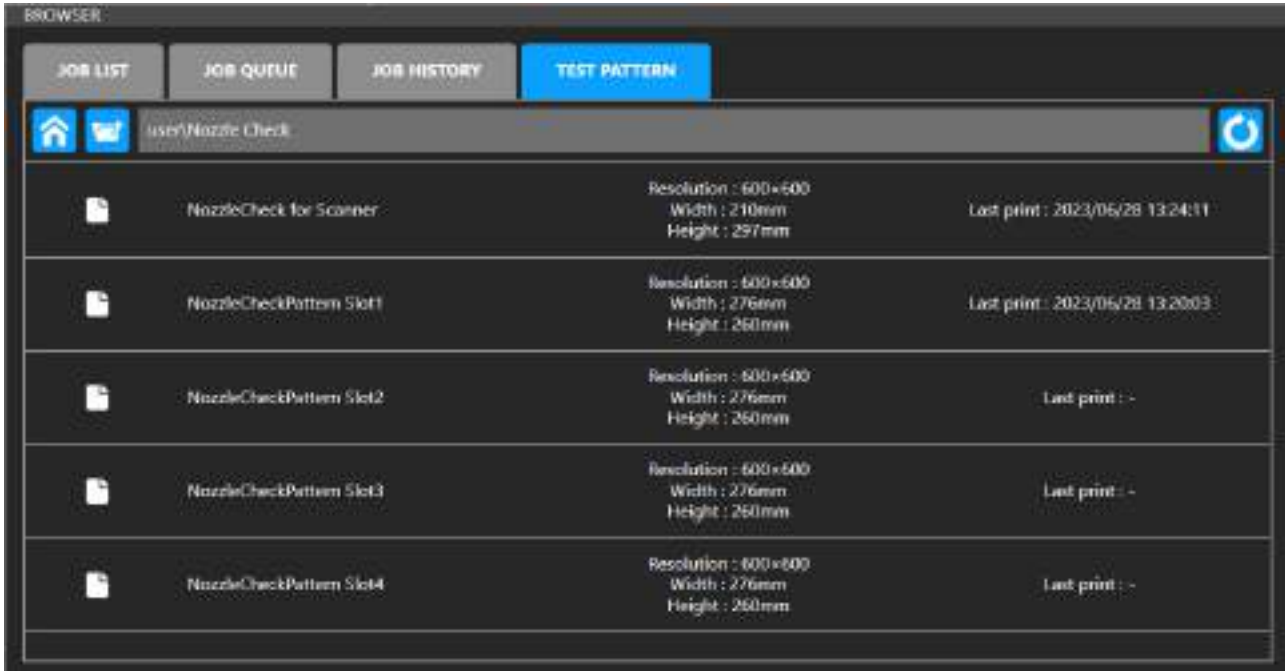

- 3 Tap [Print].
 - Test printing starts.
 - All nozzles corresponding to the tapped color perform ejection.
- 4 Check the print results.
 - Check the nozzle number for locations with clogged nozzles.

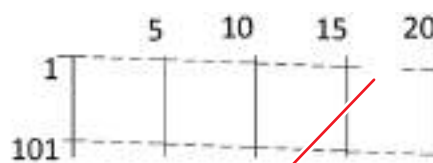

In this case, nozzles 17 and 18 are clogged.

- 5 From MENU on the touch panel, tap [MAINTENANCE].
 - The Maintenance menu is displayed.
- 6 Tap [Nozzle recovery] > [Regist nozzle recovery].
 - A dialog box appears. "Nozzle Recovery Registration Dialog"(P. 115)

7 Reflect the print results in the nozzle recovery table.



- (1) Set each filter as follows.
 - [Color]: Color for nozzle recovery registration
 - [Result]: ALL



- (2) In the nozzle recovery table, refer to the nozzle number of the locations with clogged nozzles in the print result, and tap the [Status] column to set it to [Abnormal].
 - Nozzles that have changed [Status] will have yellow text color.

Color	Head line	Nozzle line	Nozzle No.	Status
Black	1	4	1	Abnormal
Black	1	4	11	Abnormal
Black	1	3	15	Normal

8 Tap [Apply change].

- A dialog box appears.
- Tap [Cancel] to modify the changes.

9 Tap [Apply].

- The contents of the changes will then be applied.



Important!

- Nozzles to which changes have been applied in the nozzle recovery registration will not have results reflected even if subsequent nozzle checks are performed. (Manual registration via nozzle recovery registration takes priority.)
- To reflect the results of a nozzle check, clear the nozzle recovery registration information. ["Nozzle Recovery Registration Dialog"\(P. 115\)](#)

3.4 Setting 1 Menu

Set various print options.

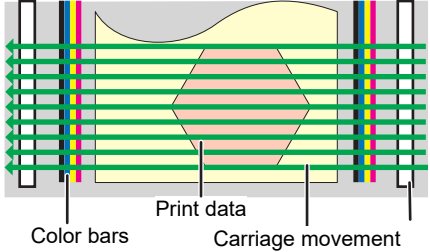
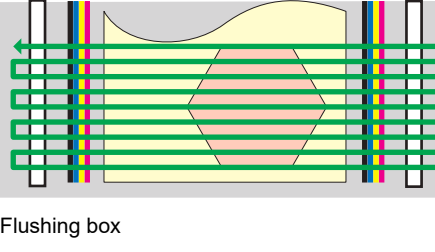
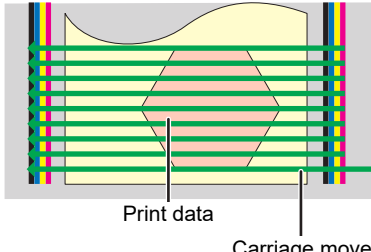
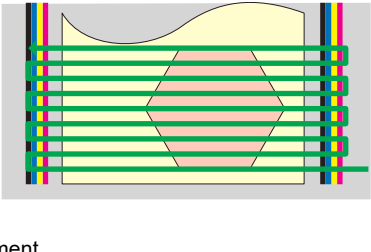
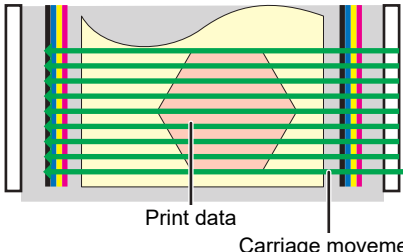
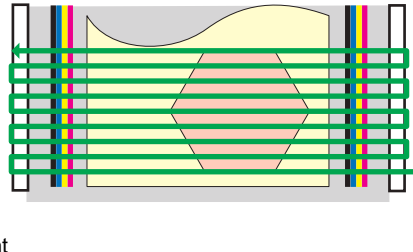

Item	Overview
Print	Set print options.
Logical seek	<p>The logical seek setting changes the behavior of the head as shown below.</p> <ul style="list-style-type: none"> - Head movement with logical seek off <div style="display: flex; justify-content: space-around; margin-top: 10px;"> <div style="text-align: center;"> <p>Unidirectional print</p>  </div> <div style="text-align: center;"> <p>Bi-directional print</p>  </div> </div> - ON: Head movement with logical seek on <div style="display: flex; justify-content: space-around; margin-top: 10px;"> <div style="text-align: center;"> <p>Unidirectional print</p>  </div> <div style="text-align: center;"> <p>Bi-directional print</p>  </div> </div> <p>For levels 1 to 3, the carriage moves to the flushing box for refresh operation.</p> <div style="display: flex; justify-content: space-around; margin-top: 10px;"> <div style="text-align: center;"> <p>Unidirectional print</p>  </div> <div style="text-align: center;"> <p>Bi-directional print</p>  </div> </div>
Refresh	<p>Reduces nozzle clogging by regularly discharging ink from the print heads.</p> <ul style="list-style-type: none"> • Level: More ink is discharged for higher level numbers.
Pre feed	Turn on to allow pre feed length to be set.
Select head	Sets the head line used.
Select head operation manual	Allows the head selection operation manual to be viewed.
Dry feed	Sets the feed distance when drying.
Add feed	Sets the additional feed distance.
Color bar	<ul style="list-style-type: none"> • Position: Sets the position for printing a color bar. - Off: No color bar is printed.

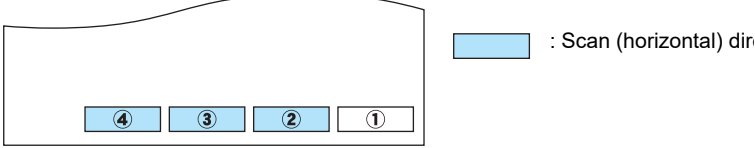
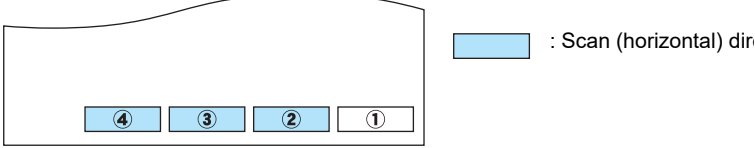
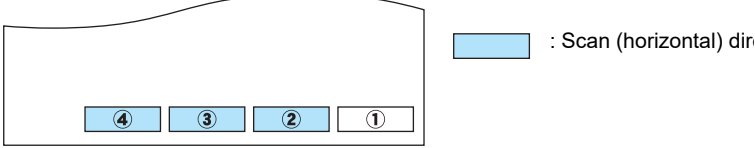
Item	Overview						
	<ul style="list-style-type: none"> – Right side: Prints on the right side of the print data. – Left side: Prints on the left side of the print data. – Both sides: Prints on both sides of the print data. • Discharge amount: Sets the amount of ink discharged on the color bar. Selecting a larger amount makes the color bar bolder. The width also varies according to the print conditions. • Wrap : Sets whether the color bars will be printed on top of each other. <ul style="list-style-type: none"> – -Off: Prints without overlapping color bars. – -On: Prints the color bars overlaid. 						
MAPS	<p>MAPS: Mimaki Advanced Pass System</p> <ul style="list-style-type: none"> • This function disperses the boundaries between passes to make feed streaks between passes less visible. • Altering MAPS may alter the color. This function may be less effective with certain types of images. 						
<table border="1" style="width: 100%; border-collapse: collapse;"> <tr> <td data-bbox="193 696 379 770">MAPS preset 1 setting</td> <td data-bbox="379 696 1441 931" rowspan="3"> <p>Register a preset of your choice.</p> <ul style="list-style-type: none"> • Speed: Reducing speeds will make streaks less visible. However, printing will be slower. • Smoothing: Increasing smoothing makes streaks less visible. </td> </tr> <tr> <td data-bbox="193 770 379 844">MAPS preset 2 setting</td> </tr> <tr> <td data-bbox="193 844 379 931">MAPS preset 3 setting</td> </tr> <tr> <td data-bbox="193 931 379 1010">Default MAPS</td> <td data-bbox="379 931 1441 1010"> <p>Set your preferred preset from 1 to 3 as described above or set to Auto. This should normally be set to Auto.</p> </td> </tr> </table>	MAPS preset 1 setting	<p>Register a preset of your choice.</p> <ul style="list-style-type: none"> • Speed: Reducing speeds will make streaks less visible. However, printing will be slower. • Smoothing: Increasing smoothing makes streaks less visible. 	MAPS preset 2 setting	MAPS preset 3 setting	Default MAPS	<p>Set your preferred preset from 1 to 3 as described above or set to Auto. This should normally be set to Auto.</p>	
MAPS preset 1 setting	<p>Register a preset of your choice.</p> <ul style="list-style-type: none"> • Speed: Reducing speeds will make streaks less visible. However, printing will be slower. • Smoothing: Increasing smoothing makes streaks less visible. 						
MAPS preset 2 setting							
MAPS preset 3 setting							
Default MAPS	<p>Set your preferred preset from 1 to 3 as described above or set to Auto. This should normally be set to Auto.</p>						
Internal pattern	<p>Set the print position for printed patterns used in test printing or for correcting the drop position.</p>						
<table border="1" style="width: 100%; border-collapse: collapse;"> <tr> <td data-bbox="193 1102 379 1337">Origin shift</td> <td data-bbox="379 1102 1441 1337"> <ul style="list-style-type: none"> • Origin shift: Prints in the direction specified when set to ON. • Origin shift direction: Set the print direction.  </td> </tr> <tr> <td data-bbox="193 1337 379 1417">Origin shift margin</td> <td data-bbox="379 1337 1441 1417"> <ul style="list-style-type: none"> • Y margin: Sets the scan (horizontal) direction margin. </td> </tr> </table>	Origin shift	<ul style="list-style-type: none"> • Origin shift: Prints in the direction specified when set to ON. • Origin shift direction: Set the print direction. 	Origin shift margin	<ul style="list-style-type: none"> • Y margin: Sets the scan (horizontal) direction margin. 			
Origin shift	<ul style="list-style-type: none"> • Origin shift: Prints in the direction specified when set to ON. • Origin shift direction: Set the print direction. 						
Origin shift margin	<ul style="list-style-type: none"> • Y margin: Sets the scan (horizontal) direction margin. 						
Heater	<p>Sets the drying heater operation.</p> <ul style="list-style-type: none"> • Drying heater: Toggles the drying heater on and off. (Default: On) • Temperature: Specifies the heater temperature (20 to 60 °C, default: 40 °C) • OFF Time: Toggles the setting to turn off the heater after the preset time has elapsed. (Default: On) • OFF Time: The time until the heater turns off. (0 to 90 mins, default: 60 mins) 						
Feed Comp.	<p>Set the feed offset.</p> <ul style="list-style-type: none"> • Feed offset: Enter the feed offset value. • Feed offset pattern: Prints a feed offset pattern. 						

3.5 Setting 2 Menu

Set various operation-related settings.



Item	Overview
Media	Set information about media.
Media origin	Enter the media origin position.
Head gap	Entering Values Manually ☞ "Setting the Head Gap"(P. 77)
Brake Roller	Sets the brake roller. Setting a larger value increases the brake force. Set to an appropriate value to suit the media used. (Can be set in 1 % increments) <ul style="list-style-type: none"> • Brake Roller: On/Off (Default: Off) • Rear Brake L: 0 to 100 % (Default: 0 %) • Rear Brake R: 0 to 100 % (Default: 0 %) • Front Brake: 0 to 100 % (Default: 0 %)
Set media	Displays the media setting items. ☞ "Load the media."(P. 62)
Bi-directional adjustment	When using bi-directional printing, correct the drop position.☞ "Correcting the Drop Position"(P. 82)
Bi-direction adjustment value	Check the printed pattern and enter correction values.
***dpi Pattern	Select the resolution and speed to correct, then print.
Feed Control	Sets feeding
Feed Speed	Sets the feed speed.
System setting	Configure the system.
Languages	Change the touch panel display language.
Length unit	Changes the length units on the touch panel.
Temp. unit	Changes the temperature display units on the touch panel.
Network setting	Set the network address. <ul style="list-style-type: none"> • Check IP address: Shows the machine's current IP address. • DHCP: Set to ON to use the IP address assigned by the DHCP server.
Print speed. unit	Change the unit of print speed displayed on the job status screen.

Function of Brake

Tiger 600-1800TS has rollers with braking functions on the folding rollers. It controls the friction torque of the folding roller and improves feed accuracy and winding performance.

1. Brake roller: Brake configurable by MPC
2. Winding unit brush roller: Controllable fixed or non-fixed with slit Collar.



- Depending on the paper and printing conditions, feed accuracy and winding performance may deteriorate. Please check the printing with the paper want to use and decide the conditions.

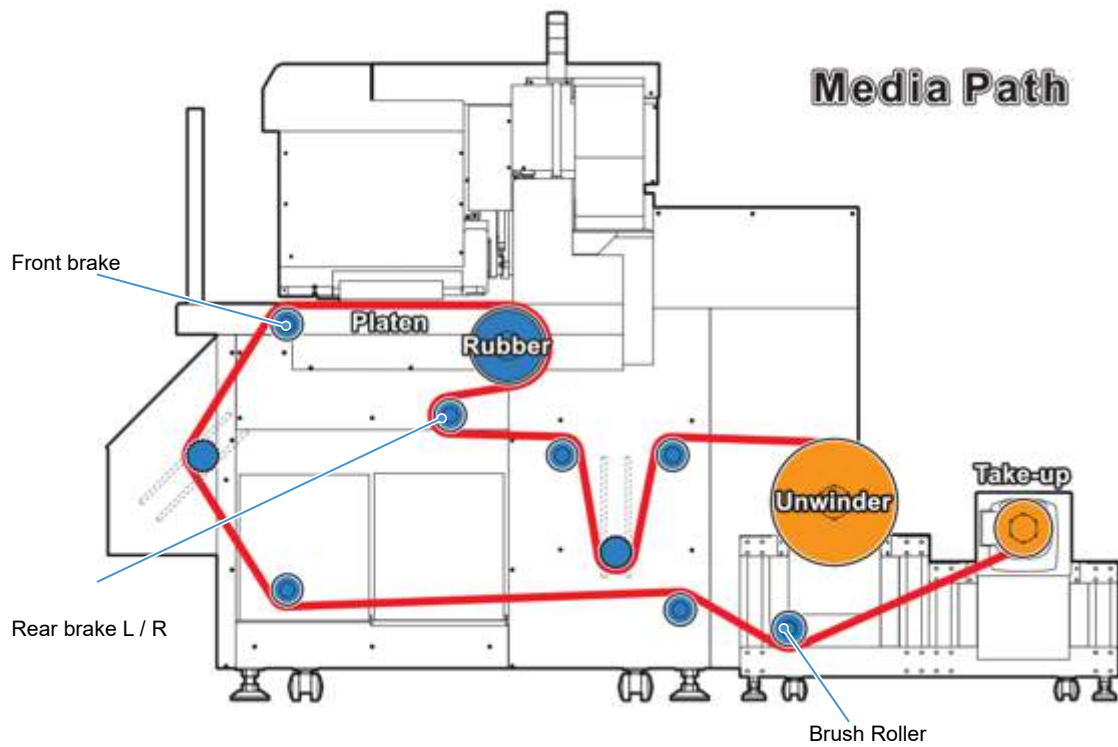

Setting_Brake roller

- From the MPC menu, tap [SETTING 2] > [Media] > [Brake Roller].

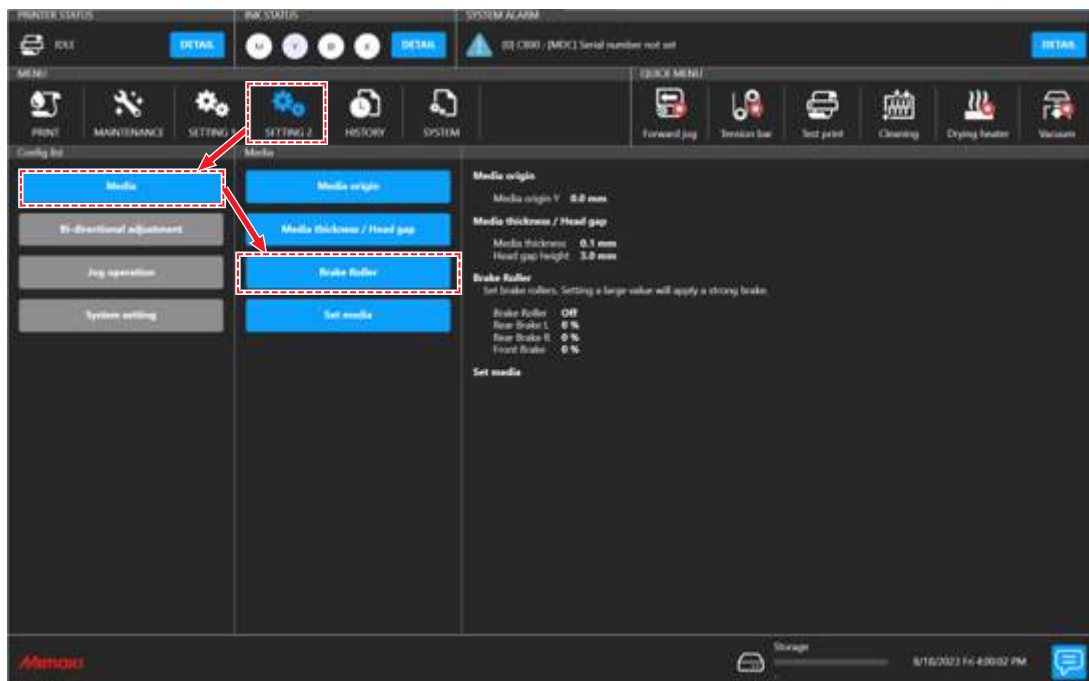

- Set the "Brake Roller conditions".

3 Tap [SET].

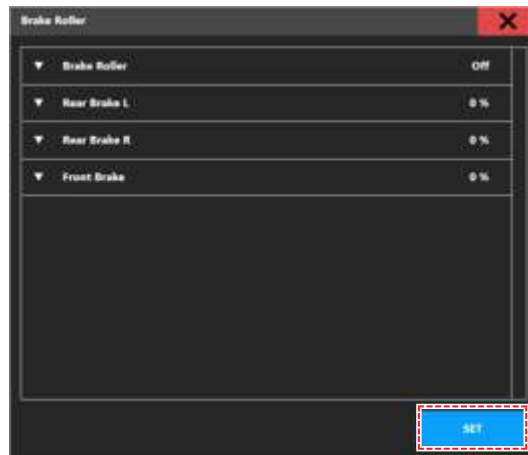

Setting_Winding Brush roller

	Lock Screw	Brush roller	Examples of use
1	Lock	Brush fixation	Basic setting
2	Un-Lock	Brush rotation	In the case of printing high-color density print data on thin transfer paper. * There is the case that wrinkles may be promoted. Basically, it is recommended to increase the amount of basis weight.

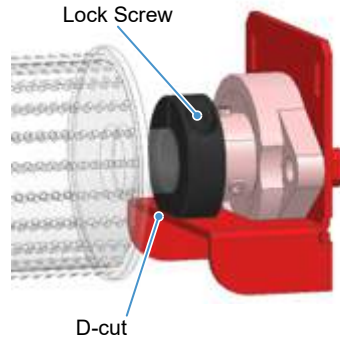

Slit collar rotates
→Rotation stop with sheet metal



brush roller rotates
The slit collar is idle rotates

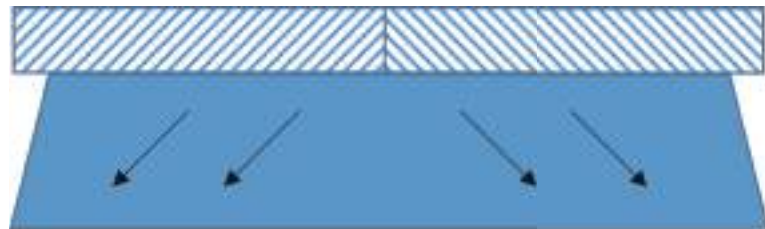

V Degree of wrinkle smoothing

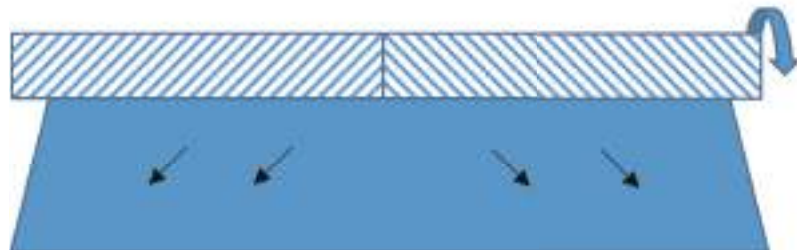

*Brush roller is driven

【Feeding conditions / Printable ink volume】

Media / Make		Jet-X / ColibriOne	TruPrint Model3 / Beaver Paper	Color / Canvas	TYD6 (MTB-110-162-188) / Inkjet (Sezo)	
Recommended environment	20~25°C / 15~60%	23°C / 50%	21~25°C / 45~55%	25°C / 45%		
Sheet weight		37gsm	33gsm	22gsm	33gsm	
Feeding conditions	K speed	Def: 250 mm/s	150 mm/s	100 mm/s	100 mm/s	
	F acceleration	Def: 6.2 G	6.2G	6.2G	6.2G	
	Wipe Rate EOP L/Max R/FSRZ	Each 0~100%	0% / 0% / 0%	5% / 5% / 0%	0% / 0% / 0%	0% / 0% / 0%
Printable ink volume	Draft 550dpi (600x600 3P B&W)	GAP ^① : 3mm in C: 2mm GAP OK	<6.5 cc/ml [<9.5 cc/ml]	<7.4 cc/ml [<7.4 cc/ml]	<5.4 cc/ml [<5.4 cc/ml]	<9.6 cc/ml [<9.6 cc/ml]
	Drying (1)	Set temperature / TC	23.0cc/ml	13.0cc/ml	18.0cc/ml	13.0cc/ml
	Cooling	GAP: 2mm / 3mm	10.0cc/ml, 11.0cc/ml	4.00cc/ml, 4.00cc/ml	10.0cc/ml, 10.0cc/ml	11.0cc/ml, 11.0cc/ml
	Wipe/erase	②③④⑤⑥⑦⑧⑨⑩⑪⑫⑬⑭⑮⑯⑰⑱⑲⑳㉑㉒㉓㉔㉕㉖㉗㉘㉙㉚㉛㉜㉝㉞㉟㊱㊲㊳㊴㊵㊶㊷㊸㊹㊺	10.0cc/ml	10.0cc/ml	10.0cc/ml	10.0cc/ml
	Standard 1100dpi (600x600 3P B&W)	GAP ^① : 3mm in C: 2mm GAP OK	9.2~11.4 cc/ml [8.0 cc/ml]	<9.6 cc/ml [<9.6 cc/ml]	<5.4 cc/ml [<5.4 cc/ml]	<12.0 cc/ml [<12.0 cc/ml]
	Drying (1)	Set temperature / TC	8.0cc/ml	18.0cc/ml	18.0cc/ml	18.0cc/ml
	Cooling	GAP: 2mm / 3mm	10.0cc/ml, 11.0cc/ml	13.0cc/ml, 11.0cc/ml	10.0cc/ml, 10.0cc/ml	10.0cc/ml, 10.0cc/ml
	Wipe/erase	②③④⑤⑥⑦⑧⑨⑩⑪⑫⑬⑭⑮⑯⑰⑱⑲⑳㉑㉒㉓㉔㉕㉖㉗㉘㉙㉚㉛㉜㉝㉞㉟㊱㊲㊳㊴㊵㊶㊷㊸㊹㊺	11.0cc/ml	10.0cc/ml	10.0cc/ml	10.0cc/ml

3.6 History Menu

Shows the machine's maintenance history and other information.





Item	Overview
Maintenance	Shows maintenance history.
Alarm	Shows the system alarm history.
Print	Shows the print history.
Controller	Shows the MPC operation history.

3.7 System menu

Shows various information about the machine.



Item	Overview
System information	Shows system information about the machine and control PC.
<ul style="list-style-type: none"> <li data-bbox="209 526 533 577">HDD disk space <li data-bbox="209 577 533 629">Machine information <li data-bbox="209 629 533 680">Version <li data-bbox="209 680 533 723">License 	<ul style="list-style-type: none"> <li data-bbox="533 526 1439 577">Shows the disk space available on the control PC. <li data-bbox="533 577 1439 629">Shows information about the machine. <li data-bbox="533 629 1439 680">Shows the machine firmware version and MPC version. <li data-bbox="533 680 1439 723">Shows license information.
Log collection	Collects the machine operating logs and settings information.
<ul style="list-style-type: none"> <li data-bbox="209 775 533 857">Manual Log collection tool <li data-bbox="209 857 533 936">Automatic Log collection tool 	<ul style="list-style-type: none"> <li data-bbox="533 775 1439 857">Collects the machine operating logs and settings information manually.  "Collecting Logs"(P. 166) <li data-bbox="533 857 1439 936">Collects the machine operating logs and settings information automatically.
Document	Shows the MPC user's guide and an error code list.
<ul style="list-style-type: none"> <li data-bbox="209 987 533 1039">Operation manual <li data-bbox="209 1039 533 1090">Alarm list <li data-bbox="209 1090 533 1164">Application Note 	<ul style="list-style-type: none"> <li data-bbox="533 987 1439 1039">Shows the MPC user's guide. <li data-bbox="533 1039 1439 1090">Shows a list of error codes. <li data-bbox="533 1090 1439 1164">Displays documents that solve problems or show how to use them in useful ways.
Service maintenance mode	This mode is exclusively for use by Mimaki representatives.
Power	Controls power to the machine and the control PC.  "Power Supply"(P. 127)
<ul style="list-style-type: none"> <li data-bbox="209 1294 533 1346">Reset machine <li data-bbox="209 1346 533 1429">Reboot System <li data-bbox="209 1429 533 1505">Shutdown system 	<ul style="list-style-type: none"> <li data-bbox="533 1294 1439 1346">Used if recovery fails even after a system reset <li data-bbox="533 1346 1439 1429">Used if recovery fails even after a machine reset. The control PC will restart. The system will take some time to start up. <li data-bbox="533 1429 1439 1505">Shuts down the system. Turn off the main power supply.  "Turning Off the Power"(P. 127)

Power Supply

Do not turn off the main power supply for the machine or the power supply for the control PC. The control PC controls the machine. Turn off the power only when machine issues cannot be resolved, and always restart after turning the power off.

Turning Off the Power

- 1 From [MENU] on the touch panel, tap [SYSTEM].**
 - This displays the system menu.
- 2 Tap [POWER] > [Shutdown System].**
 - The control PC shuts down.
- 3 Turn off the main power for the machine.**
 - Turn the switch 90 degrees counterclockwise.
 - The main power supply is located on the left at the rear of the machine.

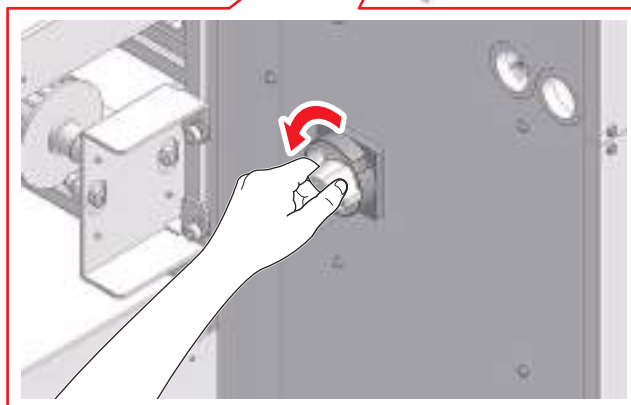
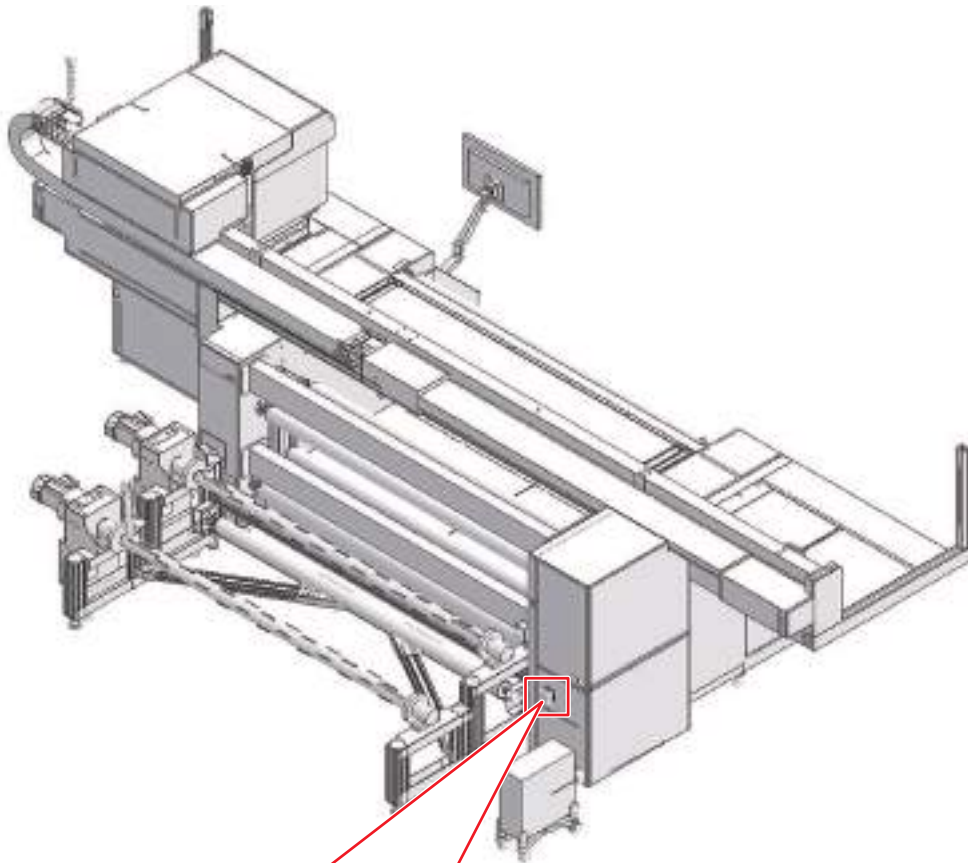

Turning On the Power

- 1 Turn the machine main power switch 90 degrees clockwise.

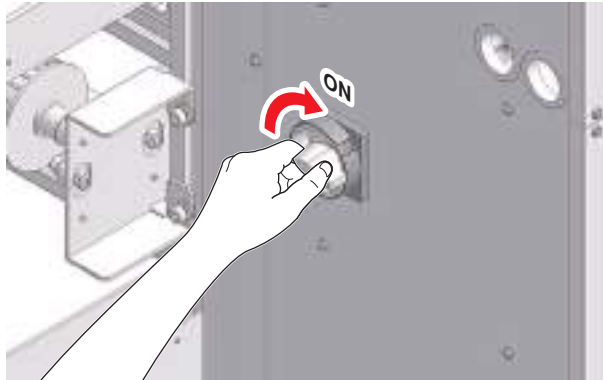

- 2 Turn on the control PC.

- This launches the MPC. The machine is ready to use.



Chapter 4 Maintenance



This chapter

To ensure years of precise performance, maintain the machine periodically based on frequency of use.

Read the maintenance precautions thoroughly before maintaining this product.

Maintenance Precautions	130	Consumable Item Replacement	143
Maintenance Timing	131	Wiper Replacement	143
Items Required for Maintenance	131	Carriage Filter Replacement	144
Performing Maintenance	132	Blower Filter Replacement	145
Ink Maintenance	132	Replace ink filter	146
Wiper Cleaning	132		
Carriage Underside Cleaning	134		
Wiper Unit Cleaning	135		
Flushing Box Cleaning	136		
Moisture Tray Cleaning	136		
Exterior Cleaning (e.g., cover, Y-bar,)	137		
Jam Sensor Detecting Plate Cleaning	138		
Platen Cleaning	139		
X Drive Roller Cleaning	139		
Blowing Fan Filter Cleaning	140		
Drying Unit Cleaning	141		
Waste Ink Tank Waste Ink Level Checking	142		

4.1 Maintenance Precautions



- This machine includes parts that must be replaced periodically. We therefore recommend taking out a maintenance contract. We recommend maintaining the machine periodically and replacing consumable item to prevent quality defects and accidents.

⚠ WARNING



- Clean periodically. Debris and dust will accumulate on electrical components when the machine is used for extended periods. There is a risk of failure, electric shock, or fire due to current leakage.
- Do not clean by blowing—e.g., avoid using air blowers. Doing so may lead to failure, electric shock, or fire involving the machine if airborne debris or dust gets inside electrical components. Wipe using a soft cloth soaked in diluted neutral detergent and thoroughly wrung out. A vacuum cleaner may also be used for cleaning.



- Take care not to allow liquids to get inside the machine. Otherwise there is a risk of failure, electric shock, or fire.

⚠ CAUTION



- For heavy soiling, wipe using a soft cloth soaked in diluted neutral detergent and thoroughly wrung out.



- Pay close attention to ventilation and be sure to wear safety glasses, gloves, and a mask when handling ink, maintenance liquid, waste ink, or other solutions used with the machine. Leaking ink may adhere to the skin or get into the eyes or mouth.



NOTICE



- Never touch the print head nozzle surface. Do not allow water or alcohol to come into contact with the print nozzle surface. This will increase the risk of machine failure or ejection failures (e.g., nozzle clogging or deflection).
- Do not use cotton swabs to clean around the head or carriage. Fibers from cotton swabs may adhere to the head nozzle surface and lead to ejection failures (e.g., nozzle clogging or deflection).
- Do not splash ink or maintenance liquid on the covers. Exposure to splashing ink or maintenance liquid may damage or deform the cover.
- Avoid using benzine, thinner, or any chemical agent containing abrasives. Use of these chemicals may result in damage to or deformation of parts.
- Do not move the carriage by hand. To move the carriage, use the carriage out function on the menu.

4.2 Maintenance Timing

Timing	Item
At the end of the work day	Clean the wiper and wiper bracket.  "Wiper Cleaning"(P. 132)
	Clean the underside of the carriage.  "Carriage Underside Cleaning"(P. 134)
	Clean the wiper unit.  "Wiper Unit Cleaning"(P. 135)
	Clean the flushing filter.  "Flushing Box Cleaning"(P. 136)
	Check the waste ink levels in the waste ink tank.  "Waste Ink Tank Waste Ink Level Checking"(P. 142)
At the end of the week's work	Clean the platen.  "Platen Cleaning"(P. 139)
	Clean the X drive roller.  "X Drive Roller Cleaning"(P. 139)
	Shake the ink.  "Ink Maintenance"(P. 132)
At the end of two weeks' work	Clean the blowing fan filter.  "Blowing Fan Filter Cleaning"(P. 140)
	Clean the jam sensor detecting plate.  "Jam Sensor Detecting Plate Cleaning"(P. 138)
	Clean the cover (exterior).  "Exterior Cleaning (e.g., cover, Y-bar,)"(P. 137)
	Clean the moisture tray.  "Moisture Tray Cleaning"(P. 136)

Items Required for Maintenance

To order replacement consumable items, contact your local dealer or our service office. For more information on consumable items, refer to our website. <https://mimaki.com/supply/inkjet.html>



- Do not store consumable items in a location where there may be children.

4.3 Performing Maintenance

Ink Maintenance

If ink constituents are sedimented, the ink density may become uneven. We recommend stirring the ink periodically to keep printing consistent.

● Shaking the Ink tank

1 Shake the Ink tank gently from left to right to ensure it is fully mixed.

- Tighten the Ink tank lid securely, then move from left to right to ensure that the ink moves inside, holding the lid with a paper towel.

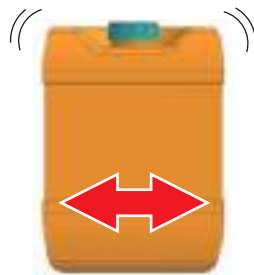

Wiper Cleaning

The wiper wipes off ink adhering to the print head nozzle surface. Continuing to use the dirty wiper may cause the wiper to which dried ink and dust are attached to rub against the nozzle surface, leading to ejection failures (e.g., nozzle clogging or deflection).



- Be careful to avoid leaving fragments from the cleaning stick behind when cleaning. These fragments will increase the risk of ejection failures (e.g., nozzle clogging or deflection).

1 From MENU on the MPC, tap [MAINTENANCE].

- The Maintenance menu is displayed.

2 Tap [Daily maintenance] > [Daily station maintenance].

- The carriage moves over the platen.

3 Switch the maintenance switch to maintenance mode. "Maintenance Switch"(P. 37)

4 Remove the wiper.

- Hold the lugs on both sides of the wiper bracket, then pull out the wiper.

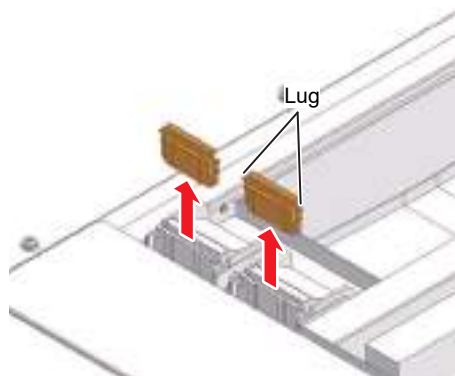

5 Clean the wiper and bracket.

- Wipe off any ink and dust adhering using a cleaning stick moistened with maintenance liquid. Wipe off the maintenance liquid. Make sure none remains.

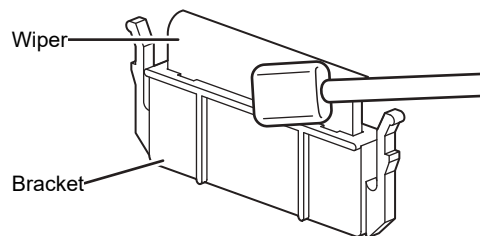

- Replace dirty or warped wipers with new ones. 🖱️ ["Wiper Replacement"\(P. 143\)](#)

6 Reattach the wiper at the original position.

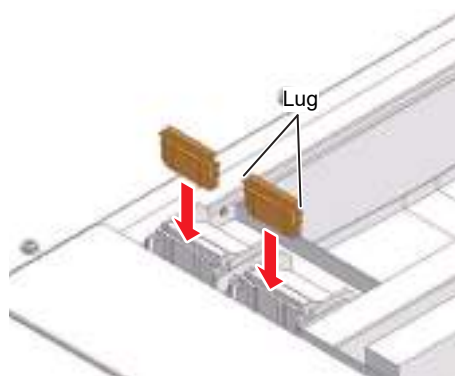

7 Switch the maintenance switch to print mode. 🖱️ ["Maintenance Switch"\(P. 37\)](#)

8 Tap [Complete] > [Finish] once cleaning is complete.

Carriage Underside Cleaning

The underside of the carriage becomes coated with ink wiped off by the wiper. Continuing to use the dirty carriage underside will rub dried ink and attached dust on to the media, resulting in contaminated prints.

The print head uses an extremely delicate mechanism. Take great care when handling it.



- Be careful to avoid leaving fragments from the cleaning stick behind when cleaning. These fragments will increase the risk of ejection failures (e.g., nozzle clogging or deflection).

- 1 From MENU on the MPC, tap [MAINTENANCE].**
 - The Maintenance menu is displayed.
- 2 Tap [Daily maintenance] > [Maintenance wizard], then tap [Head maintenance].**
 - The carriage moves to the maintenance space.
- 3 Switch the maintenance switch to maintenance mode.**  **"Maintenance Switch"(P. 37)**
- 4 Slide the maintenance cover on the left side of the Y-bar.**
 - Lift the lever and slide it to the left.

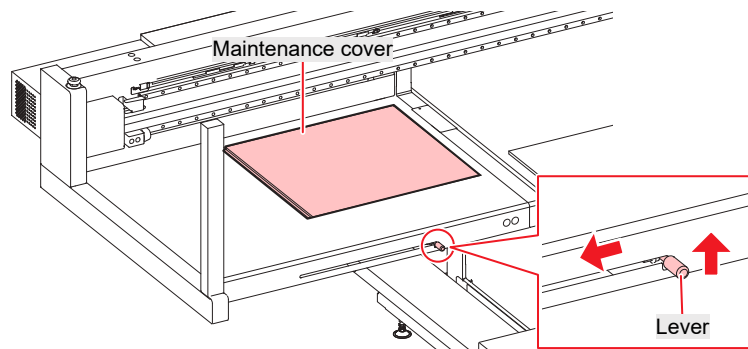

5 Clean around the print head.

- Wipe off any ink and dust adhering using a cleaning stick moistened with maintenance liquid. Wipe off the maintenance liquid. Make sure none remains.

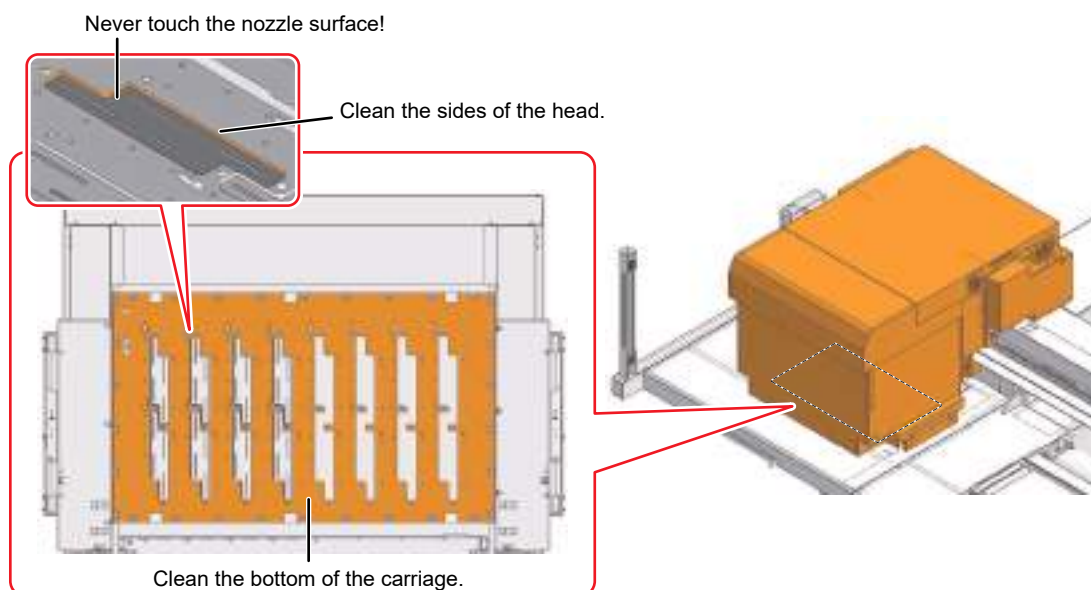



- Never touch the print head nozzle surface.

- 6** Once cleaning is complete, slide the maintenance cover on the left side of the Y-bar to close it.

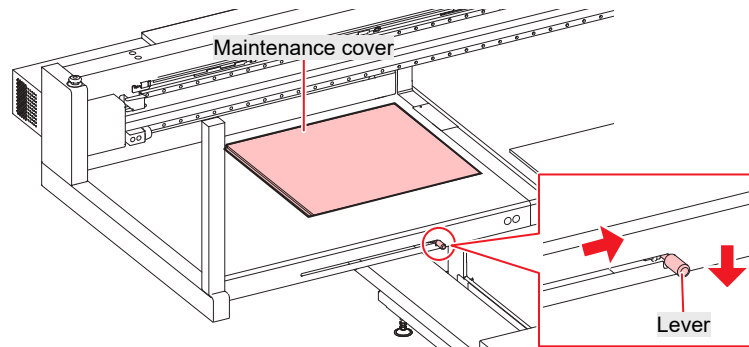

- Make sure the maintenance cover is returned to the correct position.

- 7** Switch the maintenance switch to print mode. 🖱️ **"Maintenance Switch"**(P. 37)

- 8** Tap [Complete] > [Finish].

Wiper Unit Cleaning

Continued use when dirty may prevent ink from flowing into the waste ink tank or cause dried ink and attached dust to rub against the head nozzle surface, leading to ejection failures (e.g., nozzle clogging, deflection).

- 1** From MENU on the MPC, tap [MAINTENANCE].
 - The Maintenance menu is displayed.
- 2** Tap [Weekly maintenance] > [Weekly station maintenance].
 - The carriage moves over the platen.
- 3** Switch the maintenance switch to maintenance mode. 🖱️ **"Maintenance Switch"**(P. 37)
- 4** Clean the wiper tray.
 - Wipe off any ink and dust adhering using a cleaning stick moistened with maintenance liquid. Wipe off the maintenance liquid. Make sure none remains.
 - Scrape off any dried ink with a spatula or similar tool.

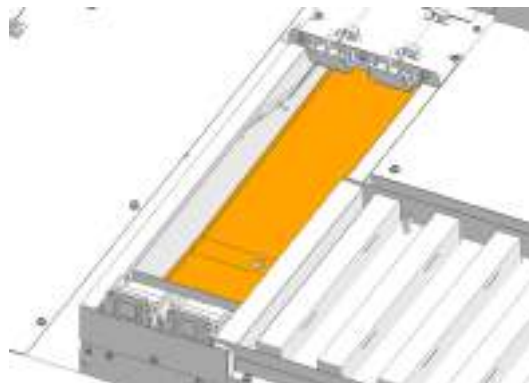

- 5 Switch the maintenance switch to print mode.  **"Maintenance Switch"(P. 37)**
- 6 Tap [Complete] > [Finish] once cleaning is complete.

Flushing Box Cleaning

The flushing box filter becomes dirty with ink during flushing. Continuing to use the dirty carriage underside will rub dried ink and attached dust on to the media, resulting in contaminated prints.

- 1 Switch the maintenance switch to maintenance mode.  **"Maintenance Switch"(P. 37)**
- 2 Use a disposable cup or similar container to rinse the contaminated parts of the filter on the left and right with purified water.



- Take care not to allow liquids to get inside the machine. Otherwise there is a risk of failure, electric shock, or fire.

- 3 Switch the maintenance switch to print mode.  **"Maintenance Switch"(P. 37)**

Moisture Tray Cleaning

Replace the water in the moisture tray periodically. Continuing to use it when it is dirty will result in contaminated prints.



- be sure to wear the included safety glasses and gloves.
- Be careful to avoid contaminating the surrounding area with ink.



- Before commencing maintenance, check to confirm that the waste ink tank is sufficiently empty (with capacity for at least 5 L) and that there is at least 3 L of purified water for replenishment.

- 1 From MENU on the MPC, tap [MAINTENANCE].
 - The Maintenance menu is displayed.
- 2 Tap [Other maintenance] > [Moisture tray maintenance].
- 3 Move the carriage to the maintenance position.
- 4 Switch the maintenance switch to maintenance mode.  **"Maintenance Switch"(P. 37)**

- 5** Open the discharge valve on the moisture tray as instructed on the wizard screen. Tap [OK], then drain the ink from the moisture tray.



- Draining takes approximately 10 minutes.

- 6** Clean the moisture tray. Once cleaning is complete, tap [OK].

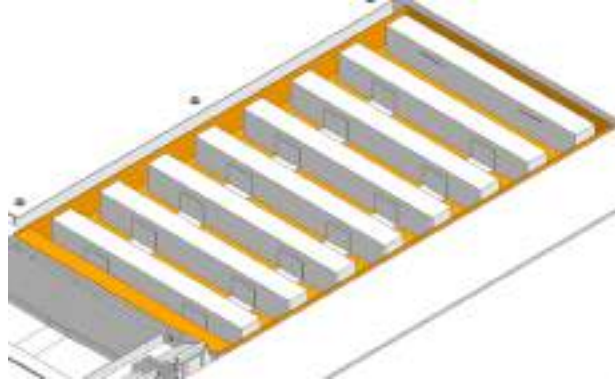

- 7** Replenish the purified water in the moisture tray. Once complete, tap [OK].

- 8** Switch the maintenance switch to print mode.  ["Maintenance Switch"\(P. 37\)](#)

- 9** Return the carriage to its original position, then tap [OK].

- 10** Exit [Moisture tray maintenance], then tap [OK].

Exterior Cleaning (e.g., cover, Y-bar,)



- Switch the maintenance switch to maintenance mode before carrying out maintenance.

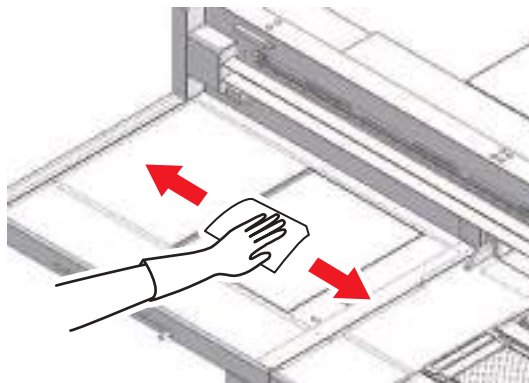

- For heavy soiling, wipe using a soft cloth soaked in diluted neutral detergent and thoroughly wrung out.



- Take care not to allow liquids to get inside the machine. Otherwise there is a risk of failure, electric shock, or fire.

LM Guide

Wipe off dust from the left and right ends of the LM guide surface with a soft dry cloth.

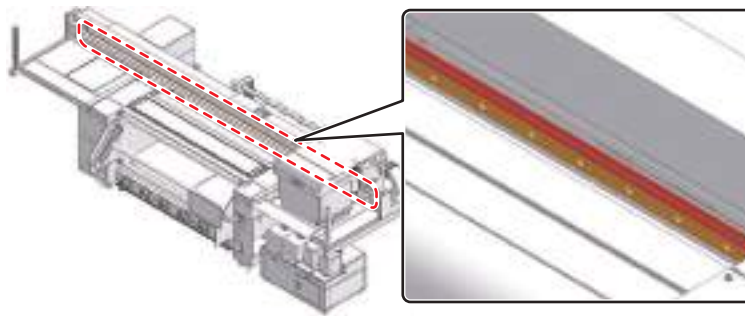

Important!

- The LM guide is lubricated. Never wipe with solvents such as ethanol. Wipe off any excess or dripping lubricant with a soft dry cloth.

Jam Sensor Detecting Plate Cleaning

Continuing to use the dirty carriage underside will rub dried ink and attached dust on to the media, resulting in contaminated prints.

1 Clean the jam sensor detecting plate.

- Clean the jam sensor detecting plate underside at the left and right sides of the carriage.
- Wipe off any ink and dust adhering using a cleaning stick moistened with maintenance liquid. Wipe off the maintenance liquid. Make sure none remains.

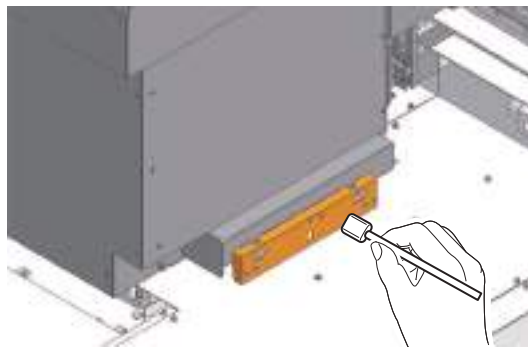

Platen Cleaning



- Switch the maintenance switch to maintenance mode before carrying out maintenance.

Continuing to use the dirty platen will prevent proper feeding of the media. It will also cause dried ink and attached dust to rub against the head nozzle surface and lead to ejection failures (e.g., nozzle clogging or deflection).

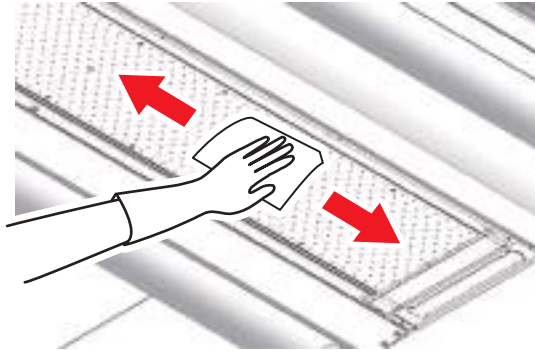

- Take care not to allow liquids to get inside the machine. Otherwise there is a risk of failure, electric shock, or fire.



- For heavy soiling, wipe using a soft cloth soaked in diluted neutral detergent and thoroughly wrung out.

X Drive Roller Cleaning



- Switch the maintenance switch to maintenance mode before carrying out maintenance.

Continuing to use the dirty platen will prevent proper feeding of the media. It will also cause dried ink and attached dust to rub against the head nozzle surface and lead to ejection failures (e.g., nozzle clogging or deflection).

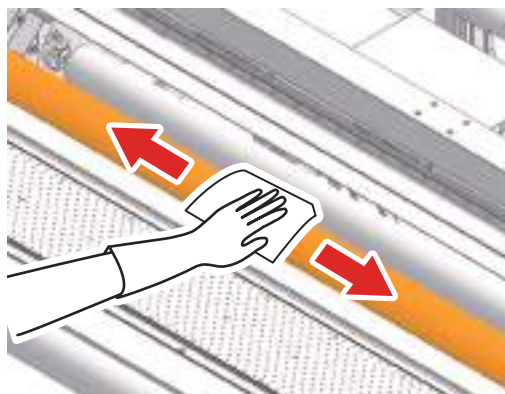

- Clean using purified water.



- Take care not to allow liquids to get inside the machine. Otherwise there is a risk of failure, electric shock, or fire.



- For heavy soiling, wipe using a soft cloth soaked in diluted neutral detergent and thoroughly wrung out.

Blowing Fan Filter Cleaning



- Switch the maintenance switch to maintenance mode before carrying out maintenance.

Wash the blowing fan filter in water if it is dirty.

● Recommended cleaning guide



- Check the filter for dirt every two weeks, and wash.
- Replace the filter every three months. Blowing Fan Filter Replacement

1 Remove the fan filter cover.

- Push the fan filter cover claw outward, and pull the cover to the front.

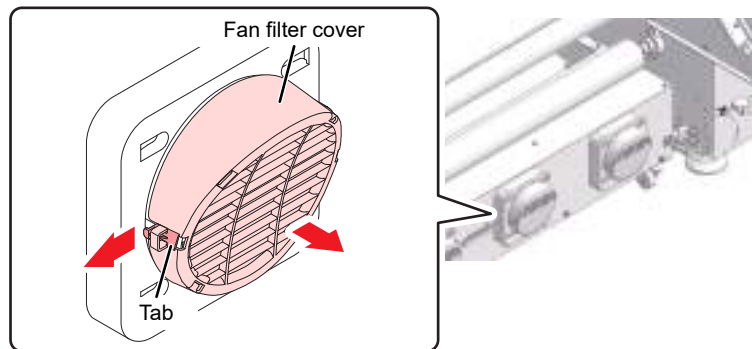

2 Remove the filter.

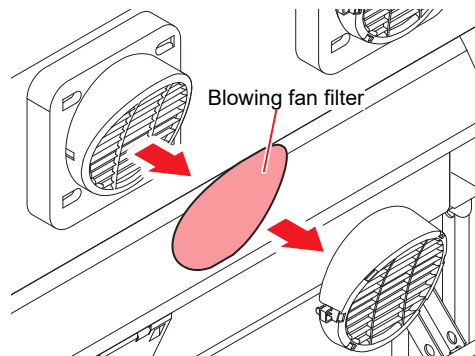

3 Wash the filter.



- Dry the filter after washing.

4 Attach the dry filter together with the fan filter cover.

- Push in the fan filter cover until the tab clicks.

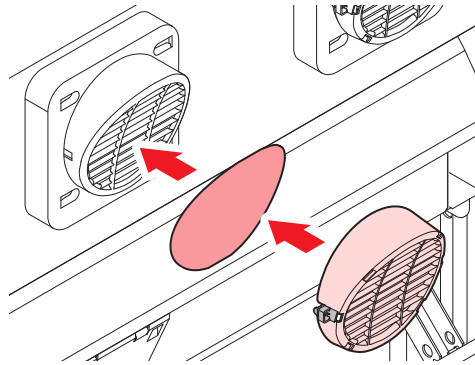

Drying Unit Cleaning



- The drying unit becomes extremely hot. Check to confirm that the unit has sufficiently cooled before commencing maintenance.



- Switch the maintenance switch to maintenance mode before carrying out maintenance.

1 From MENU on the MPC, tap [MAINTENANCE].

- The Maintenance menu is displayed.

2 Tap [Other maintenance] > [Drying unit Taking out].

- Pull out the drying unit as instructed on the wizard screen.

3 Carry out maintenance once the drying unit has been pulled out.

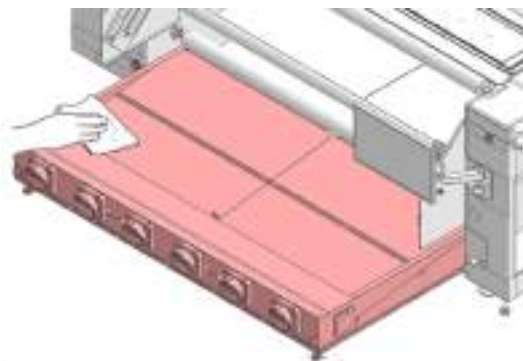

- For heavy soiling, wipe using a soft cloth soaked in diluted neutral detergent and thoroughly wrung out.



- Take care not to allow liquids to get inside the machine. Otherwise there is a risk of failure, electric shock, or fire.

Waste Ink Tank Waste Ink Level Checking

Ink used during head cleaning and other processes is collected in the waste ink tank at the lower right of the machine.



- Continuing to use the product without disposing of the waste ink may result in waste ink overflowing from the waste ink tank. Visually check the ink level in the waste ink tank every day.
-



- Pay close attention to ventilation and be sure to wear safety glasses, gloves, and a mask when handling ink, maintenance liquid, waste ink, or other solutions used with the machine. Leaking ink may adhere to the skin or get into the eyes or mouth.



4.4 Consumable Item Replacement

To order replacement consumable items, contact your local dealer or our service office.

For more information on consumable items, refer to our website. <https://mimaki.com/supply/inkjet.html>



- Do not store consumable items in a location where there may be children.



- When disposing of consumable items, contact an industrial waste disposal operator or dispose of them in accordance with the relevant laws, regulations, and local ordinances.

Wiper Replacement

The machine maintains a count of the number of wiping cycles. Once the specified value is reached, "0605 REPLACE WIPER" will appear in SYSTEM ALARM on the touch panel. Replace dirty or warped wipers with new ones.

- 1 From MENU on the MPC, tap [MAINTENANCE].**
 - The Maintenance menu is displayed.
- 2 Tap [Replace parts] > [Replace wiper].**
 - The carriage moves over the platen.
- 3 Switch the maintenance switch to maintenance mode.** ["Maintenance Switch"\(P. 37\)](#)
- 4 Remove the wiper.**
 - Hold the lugs on both sides of the wiper bracket, then pull out the wiper.

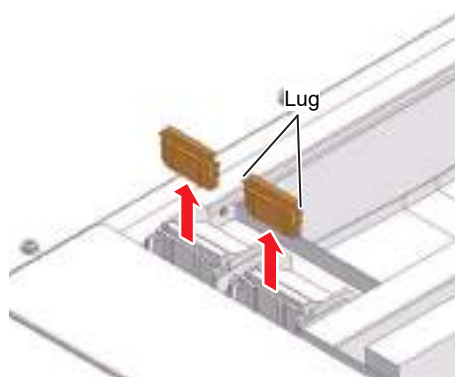

- 5 Clean the wiper cleaner.**
 - ["Wiper Cleaning"\(P. 132\)](#)

6 Mount a new wiper.

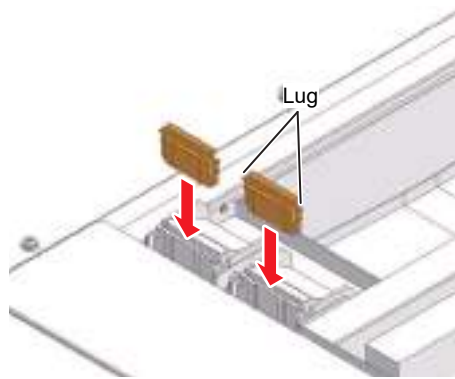

7 Switch the maintenance switch to print mode. 🖱️ ["Maintenance Switch"\(P. 37\)](#)

8 Tap [Complete] > [Finish] once replacement is complete.

- The wiper usage count is reset.

Carriage Filter Replacement

Check the mist filters and replace if very dirty.



- Switch the maintenance switch to maintenance mode before carrying out maintenance.

1 Remove the carriage filter covers.

- Remove the screws, then remove the filter covers.

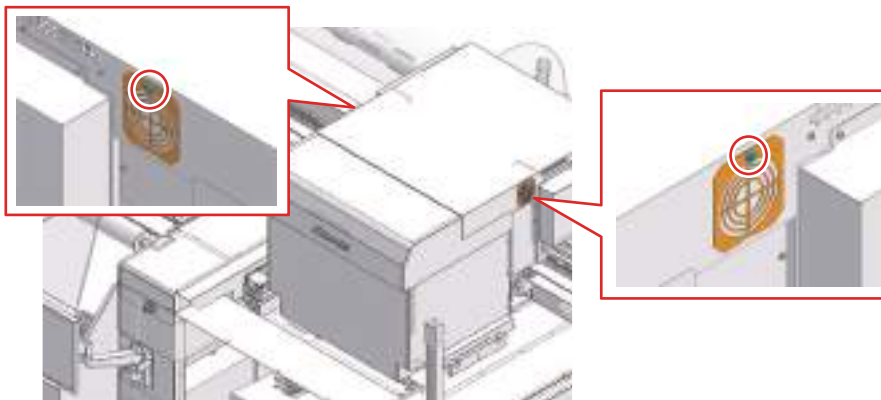

- Filters are positioned on the left and right of the carriage.

2 Install new filters.

3 Install the filter covers.

- Left and right of carriage: Fit the tabs on the bottom of the filter cover to the carriage cover, then secure with screws.

Blower Filter Replacement



- Turn off the main power before performing maintenance tasks.

1 Remove the side cover.

- Remove the knob screw, then slide the cover upward to remove it.

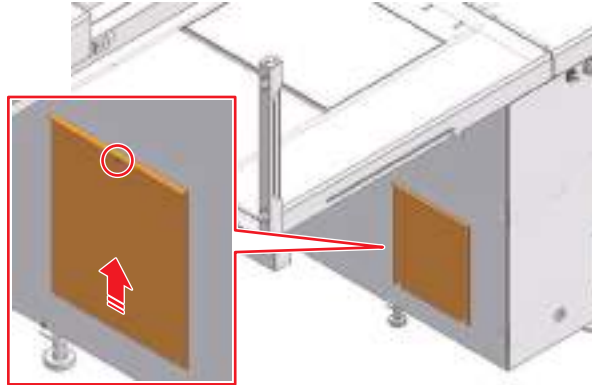

2 Remove the filter box cover.

- Remove the three filter box clamps, then remove the cover.

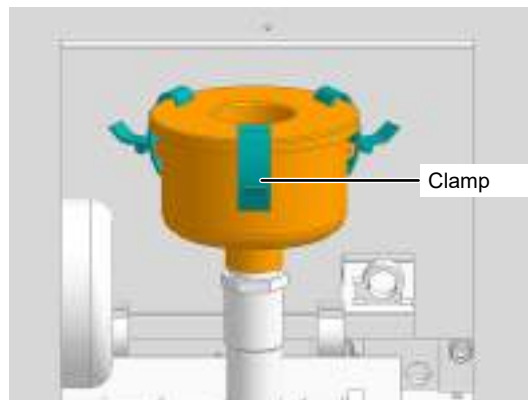

3 Replace the filter.

- Replace the cylindrical filter with a new filter.

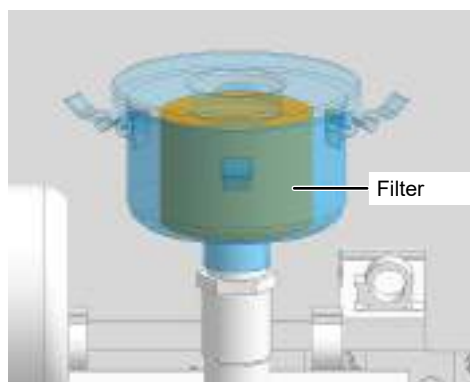

4 Reattach the filter box cover and the side cover.

- Reattach the three filter box clamps, and reattach the knob screw on the side cover.

Replace ink filter

- 1** From MENU on the touch panel, tap [MAINTENANCE].
 - The Maintenance menu is displayed.
- 2** Select [Replace parts] > [Replace ink filter] and tap [Start].
- 3** Open the F maintenance cover as instructed by the wizard.

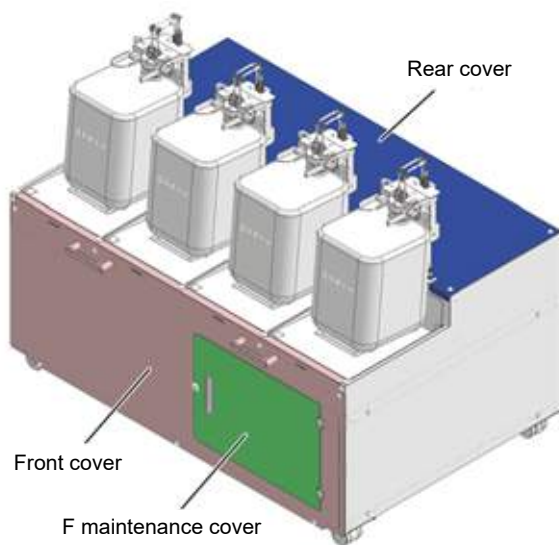

4 Remove the fitting below the filter.

- Press down on the fitting latch, then pull out the fitting.

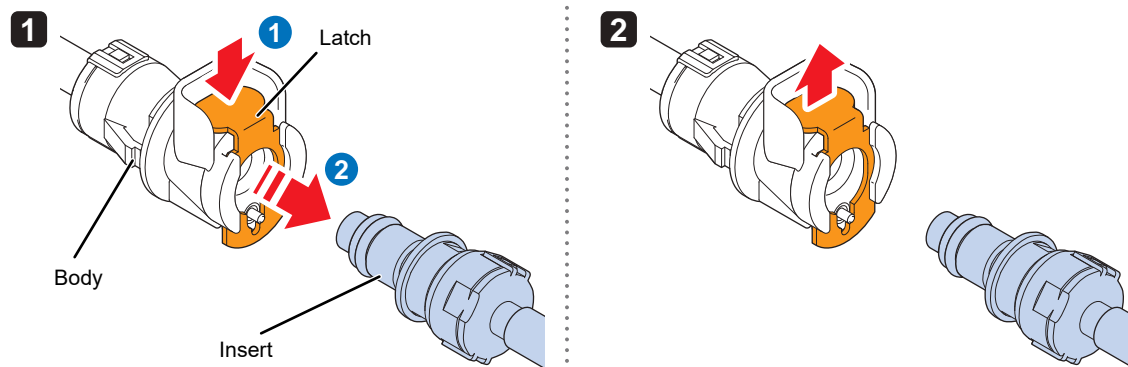
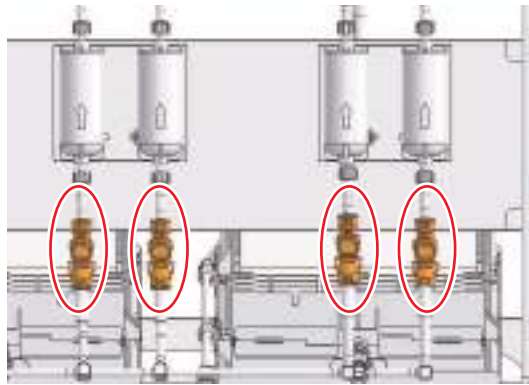

- Be sure to press down the latch fully before pulling out the insert. If you try to force out the insert without pressing down the latch fully, there is a risk of damaging the O-ring, which may cause ink leakage.

5 Remove the fitting above the filter.

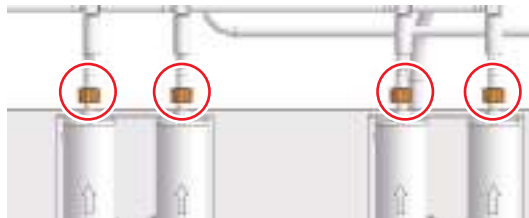

6 Detach the tube from the filter.

- When removing the tube, protect the surrounding area with paper towels or the like to prevent ink from contaminating the area before replacing the tube.



7 Attach the tubing to the new filter.



- Install the ink filter with the engraved arrow pointing upward.

8 Attach the filter to the top fitting.

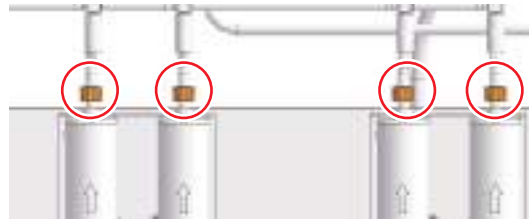

9 Install the tube into the lower fitting.



- Be sure to press down the latch fully when inserting the fitting. If you try to forcibly insert the fitting without pressing down the latch fully, there is a risk of damaging the O-ring on the fitting, which may cause ink leakage.
- Take care not to push in the valve at the tip of the fitting when connecting the fitting. If the valve is pushed in, ink may leak out, and air may enter the ink paths, causing malfunctioning.

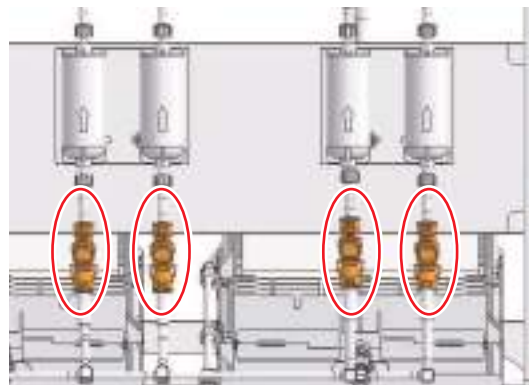
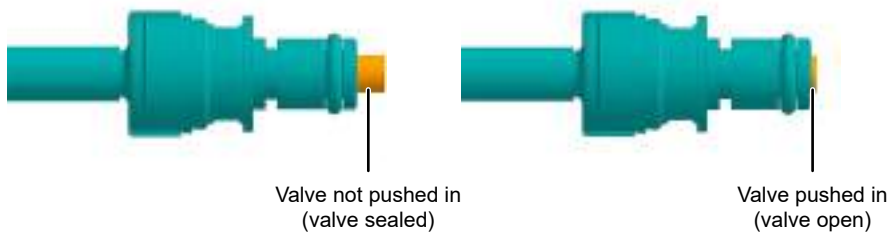

10 Check to confirm that the fittings are securely connected.

- (1) There are no gaps in the fittings.

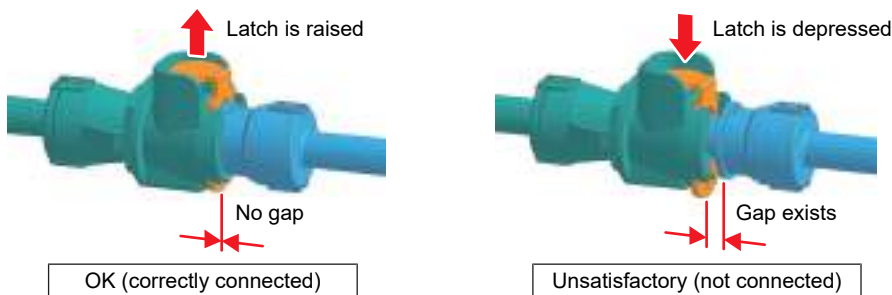

- (2) The fittings do not detach when pulled gently.

11 Close the F-maintenance cover.

Chapter 5 Troubleshooting



This chapter

This chapter describes procedures for troubleshooting and addressing messages on the display.

Troubleshooting.....	150	Image defects occur.....	151
The power does not turn on.	150	Ink has leaked out.....	153
Printing is not possible.	150	Touch panel operation is not possible.	153
The media jams or the media is dirty.	150	Problems Indicated by Messages	154
Transfer paper meandered	150	Collecting Logs.....	166

5.1 Troubleshooting

For information on troubleshooting, refer to this chapter. Refer to the Mimaki website (<https://mimaki.com/support/>) for frequently asked questions (FAQs) about the machine and customer support videos.

If the recommended corrective action does not resolve the problem, contact your local dealer or our service office.

The power does not turn on.

Points to check	Corrective action
Is the main power supply turned on?	Turn on the main power supply. ☞ "Turning On the Power"(P. 128)
Is the PRINTER STATUS icon on the touch panel set to  ?	Turn the power on. ☞ "Power Supply"(P. 127)

Printing is not possible.

Points to check	Corrective action
Is the LAN cable connected to the machine also connected to the control PC?	Insert the LAN cable connector into the LAN port until it clicks into place. ☞ "System Configuration"(P. 38)
Does an "Ink end" message appear in SYSTEM ALARM on the touch panel?	Replace with new ink. ☞ "Ink Tank Replacement Method"(P. 52)
Does a message appear in SYSTEM ALARM on the touch panel?	Take appropriate measures based on the message. ☞ "SYSTEM ALARM"(P. 102)☞ "Problems Indicated by Messages"(P. 154)

The media jams or the media is dirty.

Points to check	Corrective action
Are you using the recommended media?	Make sure you are using the recommended media. https://mimaki.com/supply/inkjet.html
Are you using curled media?	Do not use curled media or media with folded ends.

Transfer paper meandered

● Telescoped roll

When wound up to a big roll size, the media tends to protrude from the core side due to a strong force applied in the direction of the core.

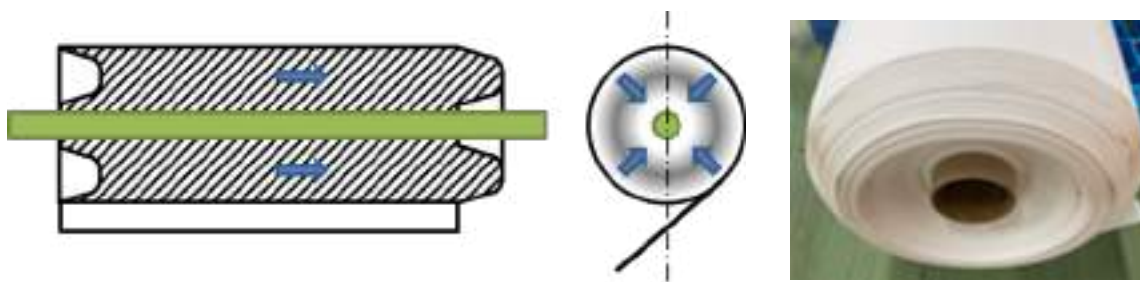

1. Pick up the winding roll at about 1500m

Telescoped roll tends to occur when winding the media over 1500m. To reduce the degree of telescoped roll and the effects of next process, pick up the roll periodically.

2. Dry the ink on the transfer paper sufficiently

Telescoped roll tends to occur also when the ink does not dry well. Check the heater setting temperature and confirm that the ink is sufficiently dry at the moment of winding.

3. Increase the passes

The degree of telescoped roll varies also depending on the length of the feed amount. The effect of telescoped roll can be reduced by increasing the pass number.

Image defects occur.

Symptom / Points to check	Corrective action
White stripes, blurs, and dark stripes occur. (Scan (horizontal) direction)	<ol style="list-style-type: none"> 1. Remove any paper scraps or other debris adhering to areas over which the print head passes. (☞ "Platen Cleaning"(P. 139) 2. Perform the procedure described in (☞ "Head Cleaning"(P. 80). 3. Perform the procedure described in (☞ "Wiper Cleaning"(P. 132). 4. Perform the procedure described in (☞ "Carriage Underside Cleaning"(P. 134).
Offsetting occurs during bidirectional printing.	<ol style="list-style-type: none"> 1. Perform the procedure described in (☞ "Correcting the Drop Position"(P. 82).
Ink droplets drip during printing.	<ol style="list-style-type: none"> 1. Perform the procedure described in (☞ "Wiper Cleaning"(P. 132). 2. Perform the procedure described in (☞ "Carriage Underside Cleaning"(P. 134). 3. Perform the procedure described in (☞ "Head Cleaning"(P. 80). 4. Set auto maintenance. (☞ "Maintenance Menu"(P. 105)
Clear clogged nozzles.	<ol style="list-style-type: none"> 1. Perform the procedure described in (☞ "Head Cleaning"(P. 80). 2. Perform the procedure described in (☞ "Wiper Cleaning"(P. 132). 3. Perform the procedure described in Ink fillup (Print head). 4. Perform the procedure described in (☞ "Wiper Replacement"(P. 143). 5. Set [MAINTENANCE] > [Nozzle recovery] > [Nozzle recovery] to "On".
Is the head gap excessive?	Reduce the head gap. If the head gap cannot be reduced, increase flushing frequency during printing (☞ "Maintenance Menu"(P. 105)) or make regular test prints to check for nozzle clogging.
Are certain ink colors used infrequently?	Increase the refresh level (☞ "Setting 1 Menu"(P. 118)) during printing. Discharge from infrequently used nozzles tends to be inconsistent. Increasing the refresh level will allow more frequent nozzle use but increase ink consumption.
Are you using media readily affected by static electricity?	Increase flushing intervals during printing (☞ "Maintenance Menu"(P. 105)☞ "Setting 1 Menu"(P. 118)) or make regular test prints to check for nozzle clogging.
Is the machine installed in a location with low humidity?	Increase the humidity by installing a humidifier or similar equipment. When printing continuously, increase flushing frequency during printing (☞ "Setting 1 Menu"(P. 118)) or make regular test prints to check for nozzle clogging.
Is the machine installed in a location with significant amounts of airborne dust or powder?	Install the machine in a location free of excessive dust or powder (office equivalent: dust levels = 0.15 mg/m ³). If the printer is installed elsewhere, make regular test prints to confirm no nozzle clogging occurs.

Cleaning the Print Head Nozzle Surface

Clean the print head nozzle surface if other cleaning or maintenance fails to resolve ejection failures (e.g., nozzle clogging, deflection).

Important!

- Allow only personnel trained by Mimaki engineers to clean the head nozzle surface. Allowing those without adequate training to clean nozzle surfaces may result in head failure.



- Use only the supplies specified by Mimaki. Cleaning with other products may cause print head wear.

- 1 From MENU on the MPC, tap [MAINTENANCE].**
 - The Maintenance menu is displayed.
- 2 Tap [Daily maintenance] > [Maintenance wizard], then tap [Head maintenance].**
 - The carriage moves to the maintenance space.
- 3 Switch the maintenance switch to maintenance mode.**  ["Maintenance Switch"\(P. 37\)](#)
- 4 Slide the maintenance cover on the left side of the Y-bar.**
 - Lift the lever and slide it to the left.

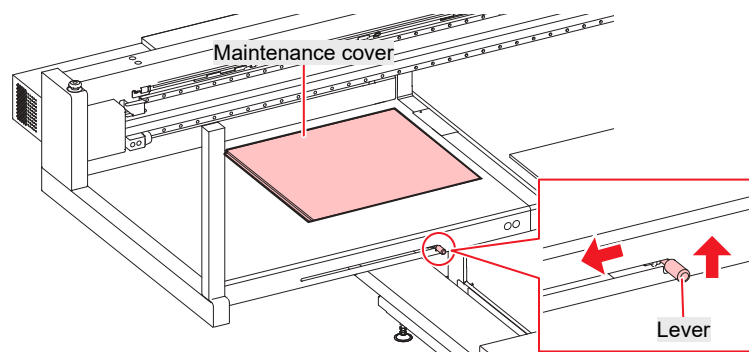

- 5 The nozzle surface is cleaned.**
 - Gently press a cleaning stick moistened with maintenance fluid against the nozzle surface for about 10 seconds.

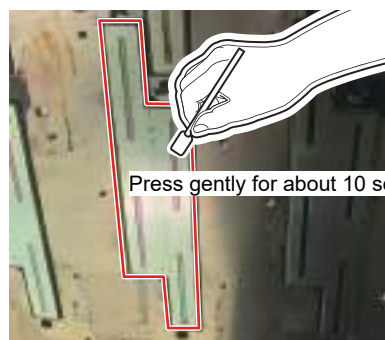

- Do not rub or press the cleaning stick with excessive force against the nozzle surface. Doing so may cause print head wear.
- Do not reuse cleaning sticks.

- 6** Once cleaning is complete, slide the maintenance cover on the left side of the Y-bar to close it.

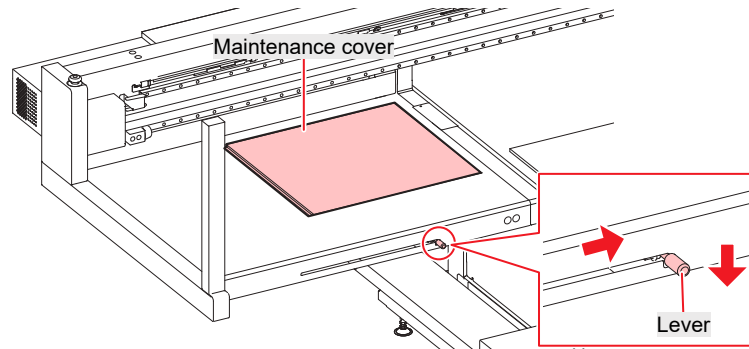

- Make sure the maintenance cover is returned to the correct position.

- 7** Switch the maintenance switch to print mode. ["Maintenance Switch"\(P. 37\)](#)

- 8** Tap [Complete] > [Finish].

- 9** Execute cleaning (in normal mode).

- ["Head Cleaning"\(P. 80\)](#)

- 10** Make a test print and check the print results.

- Repeat the cleaning and test printing process until the print results appear normal.

Ink has leaked out.



- If an ink leak occurs, turn off the main power immediately and turn off the breaker. Then, contact your local dealer or our service office.

Touch panel operation is not possible.

Points to check	Corrective action
Are any objects such as tape or labels affixed to the touch panel screen or the black outer frame?	Touch panel operation may not be possible if objects such as tape or labels are attached to it. Please remove any such objects before operation.
Is the touch panel dirty?	If it is very dirty, gently wipe off the dirt with a soft cloth.



5.2 Problems Indicated by Messages





If a problem occurs, the buzzer will sound and a message will appear in SYSTEM ALARM on the touch panel. Take appropriate measures based on the message. If a message reappears even after taking the prescribed action, contact your local dealer or our service office.







Error number	Message	Cause	Corrective action
0108	HD TYPE	<ul style="list-style-type: none"> A problem was detected with head control 	<ul style="list-style-type: none"> Turn off the control PC, then turn off the main power. Wait briefly before turning the control PC and the main power back on. If the error appears again, contact your local distributor, our sales office, or service center.
010E	FROM CLEAR	<ul style="list-style-type: none"> A problem was detected with the control PCB. 	
010F	FROM WRITE		
0115	PCB MAIN-F1		
0116	PCB MAIN-F2		
011F	PCB SLIDER		
0122	PRAM NONE		
0123	PRAM DATA		
0124	PRAM ADDR		
0127	POWER OFF		
0128	HDC FIFO		
0129	BATTERY EXCHANGE		
012A	HDC SPEED	<ul style="list-style-type: none"> A problem was detected with the print head control. 	
012D	PCB MAIN-F4	<ul style="list-style-type: none"> Blown main PCB fuse. 	<ul style="list-style-type: none"> Turn off the control PC, then turn off the main power. Wait briefly before turning the control PC and the main power back on. If the error appears again, contact your local distributor, our sales office, or service center.
012E	HeadFaild	<ul style="list-style-type: none"> A problem was detected with the head. 	
0151	Main PCB V1R2	<ul style="list-style-type: none"> A problem was detected with the main PCB power supply circuit. 	
0152	Main PCB V2R5		
0153	Main PCB V3R3		
0154	Main PCB V05		
0171	NEW HEAD CONNECT	<ul style="list-style-type: none"> New head connection detected. 	
0172	Main PCB Q6 Check	<ul style="list-style-type: none"> A problem was detected with the main PCB power supply circuit. 	
0186	HDC WAVEFLOW	<ul style="list-style-type: none"> A problem was detected with head control 	
0189	COM VOLT	<ul style="list-style-type: none"> A problem was detected with the COM voltage. 	
018C	Main PCB V12	<ul style="list-style-type: none"> A problem was detected with the main PCB power supply circuit. 	







Error number	Message	Cause	Corrective action	
018D	PCB EXIO1	<ul style="list-style-type: none"> A control PCB problem occurred. 		
018E	FLS NOT COMP	<ul style="list-style-type: none"> A problem was detected with ink ejection control. 		
018F	OFFSET WAVE			
0190	Main PCB V_V1	<ul style="list-style-type: none"> A problem was detected with the main PCB power supply circuit. 		
019E	HDC FUSE ERROR	<ul style="list-style-type: none"> Blown PCB fuse 		
01BB	COMIO VHV1	<ul style="list-style-type: none"> A control PCB problem occurred. 		
01BF	PCB MAIN-F2/F3	<ul style="list-style-type: none"> Blown main PCB fuse. 		
01D1	PCB EXIO-FUSE	<ul style="list-style-type: none"> Blown EXIO PCB fuse. 		<ul style="list-style-type: none"> Turn off the control PC, then turn off the main power. Wait briefly before turning the control PC and the main power back on. If the error appears again, contact your local distributor, our sales office, or service center.
01E7	PCB INKCTRL1	<ul style="list-style-type: none"> A control PCB problem occurred. 		
01EA	PCB EXIO2			
0201	COMMAND	<ul style="list-style-type: none"> A communication error was detected between the control PC and printer. 		
0202	PARAMETER			
0203	Ment Command			
030C	SCAN DATA TIMEOUT			
0310	PORT OPEN ERROR	<ul style="list-style-type: none"> MAIN-PE FW communication error The Ethernet ports cannot be opened between PCBs. 		
0311	ACK ERROR	<ul style="list-style-type: none"> MAIN-PE FW communication error ACK/NAK cannot be received from PE-FW. 		
0312	CMD ERROR	<ul style="list-style-type: none"> MAIN-PE FW communication error An error was detected for the command. 		
0313	CMD TIMEOUT	<ul style="list-style-type: none"> MAIN-PE FW communication error An error was detected for the command. 		
0314	NOTICE ERROR	<ul style="list-style-type: none"> MAIN-PE FW communication error Notifications cannot be received from PE-FW. 		
0401	MOTOR X	<ul style="list-style-type: none"> An error was detected with the X motor. 		
0402	MOTOR Y	<ul style="list-style-type: none"> An error was detected with the Y motor. 		
0405	STATION ERROR	<ul style="list-style-type: none"> The station attempted to move beyond the upper limit. 		

Error number	Message	Cause	Corrective action
0406	Wiper origin detection failure	<ul style="list-style-type: none"> The wiper origin could not be detected. 	
041B	MEDIA NEAR END	<ul style="list-style-type: none"> The media has been used up. Or the media roll diameter is small. 	<ul style="list-style-type: none"> Replace with new roll media.
0423	TAKE-UP TENSION-BAR	<ul style="list-style-type: none"> Take-up tension bar initialization failed. 	<ol style="list-style-type: none"> Check to confirm that the media has been correctly loaded from the printing surface to the take-up shaft. Check to confirm that the take-up shaft rotation direction switch is correctly set for the media orientation.
0424	FEEDING TENSION-BAR	<ul style="list-style-type: none"> Feeding tension bar initialization failed. 	<ol style="list-style-type: none"> Check to confirm that the media has been correctly loaded from the feeding shaft to the printing surface. Check to confirm that the feeding shaft rotation direction switch is correctly set for the media orientation.
0425	TAKE-UP TENSION_BAR DROP DOWN	<ul style="list-style-type: none"> The take-up tension bar dropped below the limit position. 	<ol style="list-style-type: none"> Check to confirm that the media is loaded via the correct path. Check to confirm that the take-up unit is rotating.
0426	FEEDING TENSION_BAR DROP DOWN	<ul style="list-style-type: none"> The feeding tension bar dropped below the limit position. 	<ol style="list-style-type: none"> Check to confirm that the media is loaded via the correct path. Check to confirm that the feeding unit is rotating.
0429	TAKE-UP TENSION-BAR LIMIT OVER	<ul style="list-style-type: none"> The feeding tension bar moved beyond the movement limit position. 	<ol style="list-style-type: none"> Check to confirm that the take-up roll is correctly loaded. Check to confirm that the take-up unit is rotating.
042A	FEEDING TENSION-BAR LIMIT OVER	<ul style="list-style-type: none"> The take-up tension bar moved beyond the movement limit position. 	<ol style="list-style-type: none"> Check to confirm that the media is loaded via the correct path. Check to confirm that the take-up unit is rotating.
0441	HEADHEIGHT WRONG	<ul style="list-style-type: none"> A problem was detected with the vertical head control. 	<ul style="list-style-type: none"> Turn off the control PC, then turn off the main power. Wait briefly before turning the control PC and the main power back on. If the error appears again, contact your local distributor, our sales office, or service center.
0449	SCAN COORD(MIN)	<ul style="list-style-type: none"> The Y movement instruction exceeded the MIN coordinates. 	<ul style="list-style-type: none"> Turn off the main power and wait briefly before turning the power back on. If the error appears again, contact your local distributor, our sales office, or service center.
044A	SCAN COORD(MAX)	<ul style="list-style-type: none"> The Y movement instruction exceeded the MAX coordinates. 	
0481	Take-up Shaft Position	<ul style="list-style-type: none"> The take-up shaft ejection position could not be detected. 	<ol style="list-style-type: none"> Re-eject the take-up shaft. If the error appears again, contact your local distributor, our sales office, or service center.

Error number	Message	Cause	Corrective action
0482	Feeding Shaft Position	<ul style="list-style-type: none"> The feeding shaft ejection position could not be detected. 	<ol style="list-style-type: none"> Re-eject the feeding shaft. If the error appears again, contact your local distributor, our sales office, or service center.
0483	Take-up INVERTER alarm	<ul style="list-style-type: none"> A take-up motor inverter unit alarm occurred. 	<ul style="list-style-type: none"> Turn off the main power and wait briefly before turning the power back on. If the error appears again, contact your local distributor, our sales office, or service center.
0484	Feeding INVERTER alarm	<ul style="list-style-type: none"> A feeding motor inverter unit alarm occurred. 	
0485	Take-up Emergency Button is pushed	<ul style="list-style-type: none"> The take-up unit emergency stop switch was pressed. 	<ul style="list-style-type: none"> Reset the emergency stop switch on the take-up unit.
0505	MEDIA JAM	<ul style="list-style-type: none"> The media jam sensor was triggered. 	<ol style="list-style-type: none"> Remove the media in contact with the carriage and reload with fresh media. Clear the alarm on the touch panel.  "Clearing Alarms"(P. 103)
0509	HDC Position count	<ul style="list-style-type: none"> A problem was detected with position control. 	<ul style="list-style-type: none"> Turn off the control PC, then turn off the main power. Wait briefly before turning the control PC and the main power back on. If the error appears again, contact your local distributor, our sales office, or service center.
050A	Y origin detection failure	<ul style="list-style-type: none"> A problem was detected with Y origin detection (initialization). 	
050F	L-SCALE BLACK	<ul style="list-style-type: none"> A problem was detected with the linear scale. 	
0511	Z origin detection failure	<ul style="list-style-type: none"> A problem was detected with Z origin detection (initialization). 	
0519	NEGATIVE PRESS SENSOR	<ul style="list-style-type: none"> Negative pressure sensor problem detected 	<ol style="list-style-type: none"> Clear the alarm on the touch panel.  "Clearing Alarms"(P. 103) If the error appears again, contact your local distributor, our sales office, or service center.
051A	POSITIVE PRESS SENSOR	<ul style="list-style-type: none"> Positive pressure sensor problem detected. 	
0531	WRONG INKTANK SENSOR	<ul style="list-style-type: none"> A problem was detected with the weight sensor on the ink supply unit. 	<ol style="list-style-type: none"> Check to confirm that the ink tank is correctly mounted, it has not been impacted, and no object has been placed on top. If the error appears even after checking, perform [Maintenance] > [Other maintenance] > [Ink tank calibration]. Turn off the control PC, then turn off the main power. Wait briefly before turning the control PC and the main power back on. If the error appears again, contact your local distributor, our sales office, or service center.
0542	Emergency switch	<ul style="list-style-type: none"> An emergency stop switch was pressed. 	<ol style="list-style-type: none"> Resolve the cause of this problem. Reset the emergency stop switch. Clear the alarm on the touch panel.  "Clearing Alarms"(P. 103) <ul style="list-style-type: none"> Clearing the alarm will start the initial operations.



Error number	Message	Cause	Corrective action
054A	PDC Position interrupt	<ul style="list-style-type: none"> No PDC position interrupt is generated. A problem occurred with the linear encoder scale or the Y motor. 	<ul style="list-style-type: none"> Turn off the control PC, then turn off the main power. Wait briefly before turning the control PC and the main power back on. If the error appears again, contact your local distributor, our sales office, or service center.
0556	Y LIMIT SENSOR	<ul style="list-style-type: none"> The carriage has exceeded the operating range in the Y direction. 	<ul style="list-style-type: none"> Contact your local distributor, our sales office, or service center.
0557	Light Curtain detects obstacle	<ul style="list-style-type: none"> The light curtain was triggered. 	<ol style="list-style-type: none"> Remove the obstacle from the light curtain detection area.  "Light Curtain"(P. 35) Clear the alarm on the touch panel.  "Clearing Alarms"(P. 103)
0558	PDC Scan position	<ul style="list-style-type: none"> A scan coordinate error occurred. 	<ul style="list-style-type: none"> Turn off the control PC, then turn off the main power. Wait briefly before turning the control PC and the main power back on. If the error appears again, contact your local distributor, our sales office, or service center.
0561	Carriage Cap Sensor	<ul style="list-style-type: none"> A problem was detected with the carriage cap sensor. 	<ul style="list-style-type: none"> Contact your local distributor, our sales office, or service center.
0601	INK NEAR END	<ul style="list-style-type: none"> Ink levels are low. 	<ul style="list-style-type: none"> Replace with a new ink bottle as follows. Install an ink tank as follows. <ol style="list-style-type: none"> Remove the bottle cap cover and detach the fitting. Load the new ink tank. Connect the fitting and attach the bottle cap cover. Execute [CLEAR ALARM]. <p>If the warning persists, contact your dealer or our sales office or call center.</p>
0602	INK END	<ul style="list-style-type: none"> Available ink has run out. 	
0603	NO INK TANK	<ul style="list-style-type: none"> No ink tank was detected. 	<ul style="list-style-type: none"> Install an ink tank as follows. <ol style="list-style-type: none"> Remove the bottle cap cover and detach the fitting. Load the new ink tank. Connect the fitting and attach the bottle cap cover. Execute [CLEAR ALARM]. <p>If the warning persists, contact your dealer or our sales office or call center.</p>
0605	REPLACE WIPER	<ul style="list-style-type: none"> It is time to replace the wiper. 	<ol style="list-style-type: none"> Replace the wiper.  "Wiper Replacement"(P. 143) Clear the alarm on the touch panel.  "Clearing Alarms"(P. 103)
0617	WRONG SUBTANK SENSOR	<ul style="list-style-type: none"> A sub-tank fluid level sensor error was detected. 	<ul style="list-style-type: none"> Turn off the control PC, then turn off the main power. Wait briefly before turning the control PC and the main

Error number	Message	Cause	Corrective action
			power back on. If the error appears again, contact your local distributor, our sales office, or service center.
061A	INK OVERFLOW	<ul style="list-style-type: none"> Sub-tank sensor limit detected 	<ol style="list-style-type: none"> Clear the alarm on the touch panel.  "Clearing Alarms"(P. 103) If the error appears even after clearing, contact your local distributor, our sales office, or service center.
061B	INK SUPPLY	<ul style="list-style-type: none"> Ink cannot be supplied to the sub-tank. 	<ol style="list-style-type: none"> Check to confirm that the ink tank fitting connection and cap cover sensor are mounted.  "Replacing the Ink Tank"(P. 52) <ul style="list-style-type: none"> This error may occur if the machine is allowed to stand for extended periods after Near End has occurred. Clear the alarm on the touch panel.  "Clearing Alarms"(P. 103) If this error continues to be displayed after clearing, turn off the control PC, then turn off the main power. Wait briefly before turning the control PC and the main power back on. If the error appears again, contact your local distributor, our sales office, or service center.
061C	NEGATIVE PRESS CONTROL	<ul style="list-style-type: none"> Negative pressure control could not be initiated. 	<ol style="list-style-type: none"> Clear the alarm on the touch panel.  "Clearing Alarms"(P. 103)
061D	NEGATIVE PRESS NOT ENOUGH	<ul style="list-style-type: none"> Proper negative pressure cannot be maintained. 	<ol style="list-style-type: none"> If the error appears again, contact your local distributor, our sales office, or service center.
061E	NEGATIVE PRESS OVER	<ul style="list-style-type: none"> Excessive negative pressure 	
061F	POSITIVE PRESS CONTROL	<ul style="list-style-type: none"> Positive pressure control could not be initiated. 	<ol style="list-style-type: none"> Clear the alarm on the touch panel.  "Clearing Alarms"(P. 103)
0620	POSITIVE PRESS NOT ENOUGH	<ul style="list-style-type: none"> Positive pressure cannot be properly maintained. 	<ol style="list-style-type: none"> If the error appears again, contact your local distributor, our sales office, or service center.
0621	POSITIVE PRESS OVER	<ul style="list-style-type: none"> Excessive positive pressure 	
0637	INK LEAK	<ul style="list-style-type: none"> Ink is leaking from the ink supply unit. 	<ol style="list-style-type: none"> Check to confirm that there are no ink leaks in the vicinity of the Ink tank. Turn off the control PC, then turn off the main power. Wait briefly before turning the control PC and the main power back on. If the error appears again, contact your local distributor, our sales office, or service center.
066B	SUBTANK EMPTY	<ul style="list-style-type: none"> There is no ink in the sub-tank. 	<ol style="list-style-type: none"> Check to confirm that the Ink tank fitting connection and cap cover sensor are mounted.  "Replacing the Ink Tank"(P. 52)
067D	INK SUPPLY WARN	<ul style="list-style-type: none"> A problem was detected with the ink supply to the sub-tank. 	

Error number	Message	Cause	Corrective action
		<ul style="list-style-type: none"> There may be a problem with the ink supply filter. 	<ul style="list-style-type: none"> This error may occur if the machine is allowed to stand for extended periods after Near End has occurred. Clear the alarm on the touch panel.  "Clearing Alarms"(P. 103) If this error continues to be displayed after clearing, turn off the control PC, then turn off the main power. Wait briefly before turning the control PC and the main power back on. If the error appears again, contact your local distributor, our sales office, or service center.
0686	Subtank Discharge	<ul style="list-style-type: none"> The sub-tank discharge process failed. 	<ol style="list-style-type: none"> Clear the alarm on the touch panel.  "Clearing Alarms"(P. 103) If the error appears again, contact your local distributor, our sales office, or service center.
0687	Purified Water Tank None	<ul style="list-style-type: none"> The purified water tank was not detected. 	<ol style="list-style-type: none"> Check to confirm that the purified water tank is correctly mounted, then press [CLEAR ALARM].  "Clearing Alarms"(P. 103) If the error appears again, contact your local distributor, our sales office, or service center.
0688	Purified Water END	<ul style="list-style-type: none"> There is no purified water in the purified water tank. 	<ol style="list-style-type: none"> Check to confirm that there is sufficient purified water in the purified water tank, then press [CLEAR ALARM].  "Clearing Alarms"(P. 103)
0689	Purified Water NEAR END	<ul style="list-style-type: none"> There is only a little purified water remaining in the purified water tank. 	<ol style="list-style-type: none"> If the error appears again, contact your local distributor, our sales office, or service center.
068A	Purified Water Tank Sensor	<ul style="list-style-type: none"> A problem was detected with the purified water tank sensor (load cell). 	<ol style="list-style-type: none"> Perform [Maintenance] > [Other maintenance] > [Purified water tank calibration]. If the error appears again, contact your local distributor, our sales office, or service center.
068B	Check InkTank Cap	<ul style="list-style-type: none"> The supply unit cap was detected as detached. 	<ol style="list-style-type: none"> Check to confirm that the supply unit Ink tank cap cover is correctly attached, then press [CLEAR ALARM].  "Clearing Alarms"(P. 103) If the error appears again, contact your local distributor, our sales office, or service center.
068C	ST Tub Level Sensor	<ul style="list-style-type: none"> A problem was detected with the station moisture tray fluid level sensor. 	<ol style="list-style-type: none"> Clear the alarm on the touch panel.  "Clearing Alarms"(P. 103) If the error appears again, contact your local distributor, our sales office, or service center.
068D	ST Tub solution Low	<ul style="list-style-type: none"> The station moisture tray fluid level is below the minimum. 	<ol style="list-style-type: none"> Check the fluid level in the station moisture tray, and replenish with purified water if it is low.

Error number	Message	Cause	Corrective action
			<ol style="list-style-type: none"> Press [CLEAR ALARM] after replenishing the purified water. "Clearing Alarms"(P. 103) If the error appears again, contact your local distributor, our sales office, or service center.
068E	ST Tub solution Full	<ul style="list-style-type: none"> The station moisture tray fluid level exceeds the maximum. 	<ol style="list-style-type: none"> Clear the alarm on the touch panel. "Clearing Alarms"(P. 103) Clearing an alarm will attempt draining for up to 20 seconds. If the alarm is still displayed even after you clear it multiple times, or if fluid is not drained to the waste ink tank when the alarm is cleared, contact your local distributor, our sales office, or service center.
068F	ST Tub solution Supply	<ul style="list-style-type: none"> A problem was detected with the station moisture tray purified water supply. 	<ol style="list-style-type: none"> Check to confirm that the purified water tank is correctly mounted, then press [CLEAR ALARM]. "Clearing Alarms"(P. 103) If the error appears again, contact your local distributor, our sales office, or service center.
0690	Negative Press Leak	<ul style="list-style-type: none"> A problem was detected with the negative pressure control system. 	<ol style="list-style-type: none"> Clear the alarm on the touch panel. "Clearing Alarms"(P. 103) If the error appears again, contact your local distributor, our sales office, or service center.
0691	INK LEAK in Carriage	<ul style="list-style-type: none"> The ink leak sensor inside the carriage was triggered. 	<ol style="list-style-type: none"> Check to confirm that there are no ink leaks in the vicinity of the carriage. Turn off the control PC, then turn off the main power. Wait briefly before turning the control PC and the main power back on. If the error appears again, contact your local distributor, our sales office, or service center.
0702	THERMISTOR CONNECT	<ul style="list-style-type: none"> A heater thermistor connection error occurred. 	<ul style="list-style-type: none"> Turn off the control PC, then turn off the main power. Wait briefly before turning the control PC and the main power back on. If the error appears again, contact your local distributor, our sales office, or service center.
0703	Heater temperature not reached	<ul style="list-style-type: none"> Heater does not reach set temperature after heating for a certain period of time. 	<ol style="list-style-type: none"> Make sure the room is within the usable temperature. "Specifications"(P. 170) Verify that the voltage is within the rated voltage range of the equipment. "Specifications"(P. 170) Lower the heater setting temperature and see if an error occurs. Turn off the control PC, then turn off the main power. Wait briefly before turning the control PC and the main power back on.

Error number	Message	Cause	Corrective action
			5. If the error appears again, contact your local distributor, our sales office, or service center.
0710	HEATER TEMP ERROR	<ul style="list-style-type: none"> A problem was detected with the heater temperature. 	
0759	HEATER UNCONNECTED	<ul style="list-style-type: none"> The drying heater is not connected. 	<ol style="list-style-type: none"> Connect the connectors on the left and right of the drying unit. If the error appears again, contact your local distributor, our sales office, or service center.
075A	SSR cooling fan abnormal	<ul style="list-style-type: none"> The SSR cooling fan has stopped. 	<ul style="list-style-type: none"> Turn off the control PC, then turn off the main power. Wait briefly before turning the control PC and the main power back on. If the error appears again, contact your local distributor, our sales office, or service center.
075B	Drying fan abnormal	<ul style="list-style-type: none"> The drying fan has stopped. 	
075C	Drying fan sensing thermistor connection	<ul style="list-style-type: none"> A connection error of the thermistor used to detect drying fan operation error occurred. 	
075D	SSR operation abnormal	<ul style="list-style-type: none"> SSRs are not turned off. 	
0801	(C)OPCODE	<ul style="list-style-type: none"> A problem was detected with the control PCB. 	
0802	(C)SWI		
0803	(C) PFTCH ABRT		
0804	(C) DATA ABRT		
0806	FW/SIO bit		
0807	FW/SIO wbsy		
080E	FW/FROM prm		
080F	FW/SIO vch		
0811	FW/SIO read		
0815	FW/SIO rsrc		
0816	FW/FROM WRC		
0817	FW/SaveArea		
081B	FW/STACK OV		
0826	FW/PrmSaveBuf		
0828	Unexpected ERROR	<ul style="list-style-type: none"> A problem was detected with the control PCB. 	
0829	FW/ERASE TIMEOV		
083A	PARAMETER ERROR	<ul style="list-style-type: none"> A parameter error was detected. 	
083B	MESSAGE ERROR	<ul style="list-style-type: none"> A message between tasks contained an invalid value. 	

Error number	Message	Cause	Corrective action
0916	ROM MISMATCH	<ul style="list-style-type: none"> The wrong firmware may have been updated. 	<ul style="list-style-type: none"> Check to determine if the firmware is for the machine. If the firmware is correct for the machine, contact your local distributor, our sales office, or service center.
0917	WIPER MOVE	<ul style="list-style-type: none"> Wiper operation error. 	<ul style="list-style-type: none"> Turn off the control PC, then turn off the main power. Wait briefly before turning the control PC and the main power back on. If the error appears again, contact your local distributor, our sales office, or service center.
091D	COVER OPEN	<ul style="list-style-type: none"> The maintenance cover is open. 	<ol style="list-style-type: none"> Close the maintenance cover. Clear the alarm on the touch panel.  "Clearing Alarms"(P. 103)
0935	Mode change failure	<ul style="list-style-type: none"> The maintenance switch was operated while the machine was under mechanical control. 	<ul style="list-style-type: none"> Clear the alarm on the touch panel.  "Clearing Alarms"(P. 103)
0B1A	PCB BaseIO	<ul style="list-style-type: none"> BaseIO PCB could not be detected. 	<ul style="list-style-type: none"> Turn off the control PC, then turn off the main power. Wait briefly before turning the control PC and the main power back on. If the error appears again, contact your local distributor, our sales office, or service center.
0B1E	PCB BaseIO-FUSE	<ul style="list-style-type: none"> Blown BaseIO PCB fuse. 	
0B25	HDC DIRECTION	<ul style="list-style-type: none"> A problem was detected with the scan control. 	
0B35	HD VLT ERR	<ul style="list-style-type: none"> HD driver voltage 26 V error detected. 	
0B36	PCB INKIO	<ul style="list-style-type: none"> INKIO PCB could not be detected. 	
0B37	PCB WFIO	<ul style="list-style-type: none"> WFIO PCB could not be detected. 	
0B38	HD DRV V26	<ul style="list-style-type: none"> HD driver voltage 26 V \pm5 % error 	
0B39	PCB WFIO-FUSE	<ul style="list-style-type: none"> Blown WFIO PCB fuse. 	
0B3E	PCB LOADCELL AD	<ul style="list-style-type: none"> A problem was detected with the load cell AD PCB. 	
0B48	PCB HDCE	<ul style="list-style-type: none"> A control PCB problem occurred. 	
0B49	PCB HDCE-VHVFET		
0B4A	PCB HDCE-FUSE		
0B4B	HDCE PCB V1R2	<ul style="list-style-type: none"> A power supply problem occurred. 	
0B4C	HDCE PCB V2R5		
0B4D	HDCE PCB V3R3		
0B54	PCB INKIO-FUSE	<ul style="list-style-type: none"> Blown INKIO PCB fuse. 	<ul style="list-style-type: none"> Turn off the control PC, then turn off the main power. Wait briefly before turning the control PC and the main power back on. If the error appears again, contact your local distributor, our sales office, or service center.
0D09	HD MEMORY	<ul style="list-style-type: none"> Head internal memory access error. 	

Error number	Message	Cause	Corrective action
0D0B	HD CONNECT	<ul style="list-style-type: none"> A problem was detected with the head connector conversion PCB connection. 	
0D0C	HD THERMIS	<ul style="list-style-type: none"> Head temperature error. An invalid temperature was detected for the specified head in the head connection check. 	
0D1C	HD BUSY	<ul style="list-style-type: none"> Communication with the print head is not possible. 	
0D1D	HD CMD		
0D1E	HD DRIVE HOT	<ul style="list-style-type: none"> A problem was detected with print head temperature. 	
C101	Command Format ERROR	<ul style="list-style-type: none"> A communication error was detected between the control PC and firmware. 	<ul style="list-style-type: none"> Turn off the control PC, then turn off the main power. After confirming that the LAN cable on the rear of the control PC is properly connected, turn the power back on. If the error appears again, contact your local distributor, our sales office, or service center.
C102	Notify receive ERROR		
C103	Response receive ERROR		
C104	No Parameters		
C105	Invalid parameter		
C106	Response set ERROR	<ul style="list-style-type: none"> An invalid parameter was received. 	
C107	Notice Response ERROR	<ul style="list-style-type: none"> Notification of abnormal completion was received. 	
C111	Print data transmission error	<ul style="list-style-type: none"> A communication error was detected between the control PC and firmware. 	
C801	Destination specification error	<ul style="list-style-type: none"> Problem detected with machine connection 	<ul style="list-style-type: none"> The device configuration settings are incorrect. contact your local distributor, our sales office, or service center.
C802	Device composition ERROR		
C803	Version mismatch	<ul style="list-style-type: none"> Problem detected with version of units in the system 	<ul style="list-style-type: none"> The version of units in the system is incorrect. contact your local distributor, our sales office, or service center.
C998	System error (datasize)	<ul style="list-style-type: none"> An unexpected error (other than an exception) occurred. 	<ul style="list-style-type: none"> Turn off the control PC, then turn off the main power. Wait briefly before turning the control PC and the main power back on.
CC10	Cannot execute automatic cleaning	<ul style="list-style-type: none"> Auto cleaning failed. 	<p>Auto maintenance cannot be performed, or an error occurred during performing maintenance. Do the following:</p> <ol style="list-style-type: none"> Confirm that the carriage is in the parking position. Confirm that there are no ink supply system errors.
CC11	Cannot execute automatic flushing	<ul style="list-style-type: none"> Auto flushing failed. 	

Error number	Message	Cause	Corrective action
			3. Clear all errors that have occurred. 4. If necessary, perform a machine reset.
CC20	Log upload confirmation	<ul style="list-style-type: none">Log upload confirmed OK. *This will be an alarm for confirmation.	

5.3 Collecting Logs

If a problem arises with the machine, you may be requested by our service engineers or service office to collect the corresponding logs. Please follow the procedure below to collect the logs if requested.

● Log collection tool

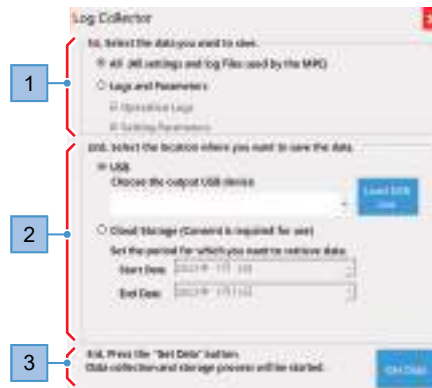

No.	Overview
1	<p>Select the data to be collected.</p> <ul style="list-style-type: none"> • All: Collects all log data. "All" should normally be selected. • Logs and Parameters: Allows either "Operation Logs" or "Setting Parameters" to be selected.
2	<p>Select a destination for saving data to.</p> <ul style="list-style-type: none"> • USB: Saves to an external hard drive. <ul style="list-style-type: none"> – Choose the output USB device: Select the external hard drive to be saved to. – Load USB list: Tap if a particular external hard drive is not listed. • Cloud Storage: Saves log data directly to Mimaki cloud storage. <ul style="list-style-type: none"> – Set the period for which you want to retrieve data: Up to 180 days of log data can be set.
3	<p>Tap [Get Data] to start log data acquisition.</p>

● Saving Log Data to an External Hard Drive

Save the logs to an external hard drive, and send the data to our service engineers by e-mail or other means.



- Please contact our service engineers if the log data volume is excessive.

- 1 Connect an external hard drive to the machine (control PC).**
- 2 From MENU on the touch panel, tap [SYSTEM] > [Log collection] > [Manual Log collection tool].**
 - The log collection tool starts up.  [P. 166](#)
- 3 Select the data to be collected.**
 - "All" should normally be selected.
- 4 Select a destination for saving data to.**
 - Select [USB], then select the external hard drive to be saved to.
- 5 Tap [Get Data].**
 - Data is saved in Zip format to the external hard drive.
Example: 20211001-0903_Tiger600_A1234567_P.zip



- The log data has been encrypted and can be sent as is.

● Uploading the Logs to Cloud Storage

If the machine is connected to the Internet, you can save the logs directly to our cloud storage platform.



- Contact your network administrator for more information regarding network connectivity.
- Please be careful of the size of the log data if you are using a metered Internet connection.

- 1 From MENU on the touch panel, tap [SYSTEM] > [Log collection] > [Manual Log collection tool].**
 - The log collection tool starts up.  [P. 166](#)
- 2 Select the data to be collected.**
 - "All" should normally be selected.
- 3 Select a destination for saving data to.**
 - Select [Cloud Storage].
- 4 Set the log data collection interval.**
 - Set the time period specified by our service engineer.

5 Tap [Get Data].

- The log data is uploaded to the cloud storage platform.
- If it is the first time using this service, the [Cloud Settings] and [ConsentFormDialog] dialog boxes will appear.

● [Cloud Settings] dialog box

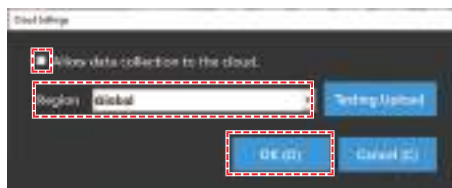

- (1) Select the following check box:
 - Allow data collection to the cloud
- (2) Select [Region], then tap [OK].
 - Global: Regions other than China
 - China: China

● [ConsentFormDialog] dialog box



- (1) Check the details described, then select the following check boxes:
 - I consent to the collection of my data in the cloud
 - I agree to the privacy policy
- (2) Tap [Agree].

6 Please notify our service engineer once the upload is complete.

Chapter 6 Appendix



This chapter

This chapter describes the specifications of the machine.

6.1 Specifications

Item		Specifications
Print head	Type	Drop-on-demand piezoelectric print head
	Specifications	8 heads (2 staggered, 4 in-line array)
	Resolution	Y: 300 dpi, 600 dpi X: 600 dpi
Ink set	4-color	B, M, Y, K
Media	Form	Roll media only (3-inch paper core internal diameter)
	Type	Transfer paper
	Max. printing width	1,850mm
	Max. mounting width	1,900mm
	Thickness	1mm以下 (Requires transport test)
	Roll spindle	3-inch air chuck shaft
	Roll external diameter	600 mm or less
	Roll weight	300 kg or less (6.6 lb or less)
	Mounting position	Center mounting
	Printing face	Exterior
	Roll end	Taped or loosely affixed to paper core
Machine accuracy	Distance accuracy (Y)	± 0.3 mm or ± 0.3 % of specified distance, whichever is greater
	Distance accuracy (X)	Intermittent feed rate $\pm 55\mu\text{m}$ or specified distance $\pm 0.3\%$, whichever is greater
	Perpendicularity	± 0.5 mm/500 mm
	Media skew	Not more than $\pm 10\text{mm}/2,000$ m
Air pressure operation unit	Air gun	Input: 0.6 to 0.8 MPa @Dry air
Printing gap		2.0mm to 4.0 mm
Origin alignment		Manual input
Ink supply	Ink capacity	2 L internal buffer tank + 10 L external supply unit
	Level detection	Weight detection (load cell)
Waste ink tank		Max. 220 mm × 350 mm × 400 mm
Purified water tank		Max. 220 mm × 350 mm × 400 mm
Drying unit		Installed underneath machine Temperature setting range: 20 to 70 °C
Interface	Data transfer function	10Gigabit Ethernet/USB3.1, USB2.0 (removable disk)
Languages		English, Japanese
Noise levels	During standby	Not exceeding 55 dB (A)
	Continuous operation	Not exceeding 68 dB (A)

Item		Specifications
Compliance with standards		IEC 62368-1 ETL compliance, CE marking (EMC Directive, Low Voltage Directive, Machinery Directive), CB certified, RoHS, REACH, RCM marking, KC certification, UKCA marking
Power supply specifications ^{*1}		AC 3-phase 4-wire 380 to 415 V ± 5 % 50/60 Hz ± 1 %, max. 25 A
Power consumption		15kW or less
Installation environment ^{*2}	Permissible ambient temperature	20 to 30 °C
	Relative humidity	35 to 65 %RH (no condensation)
	Temperature range in which accuracy is guaranteed	20 to 25°C
	Temperature gradient	Not more than ± 10 °C/h
	Dust	Not more than 0.15 mg/m ³ (equivalent to typical office)
	Maximum operating altitude	2,000m
External dimensions ^{*3}	Width	Not exceeding 5,300 mm (not exceeding 5,850 mm)
	Depth ^{*4}	Not exceeding 2,800mm (not exceeding 2,310mm)
	Height	Not exceeding 1,900 mm (not exceeding 1,950 mm)
Weight ^{*3, 5}		Not exceeding 1,620 kg (not exceeding 2,300 kg)

*1. Excluding options

*2. Ink printing consistency will decrease in conditions outside this range.

*3. The figures in parentheses indicate package dimensions.

*4. Including main unit and winding unit (excluding touch panel protruding parts)

*5. Not including weight of ink.

6.2 LICENSE Library

Mimaki printer Firmware

Copyright ©2020 MIMAKI ENGINEERING CO.,LTD. All rights reserved.

This product contain open source software listed in the tables below.

Component	License
StarterWare for ARM® based TI Sitara Processors	BSD-TI

The following license terms and conditions shall apply to the open source software listed in the table above:

BSD-TI

Copyright (C) 2010 Texas Instruments Incorporated - <http://www.ti.com/>

Redistribution and use in source and binary forms, with or without modification, are permitted provided that the following conditions are met:

1. Redistributions of source code must retain the above copyright notice, this list of conditions and the following disclaimer.
2. Redistributions in binary form must reproduce the above copyright notice, this list of conditions and the following disclaimer in the documentation and/or other materials provided with the distribution.
3. Neither the name of Texas Instruments Incorporated nor the names of its contributors may be used to endorse or promote products derived from this software without specific prior written permission.

THIS SOFTWARE IS PROVIDED BY THE COPYRIGHT HOLDERS AND CONTRIBUTORS "AS IS" AND ANY EXPRESS OR IMPLIED WARRANTIES, INCLUDING, BUT NOT LIMITED TO, THE IMPLIED WARRANTIES OF MERCHANTABILITY AND FITNESS FOR A PARTICULAR PURPOSE ARE DISCLAIMED. IN NO EVENT SHALL THE COPYRIGHT OWNER OR CONTRIBUTORS BE LIABLE FOR ANY DIRECT, INDIRECT, INCIDENTAL, SPECIAL, EXEMPLARY, OR CONSEQUENTIAL DAMAGES (INCLUDING, BUT NOT LIMITED TO, PROCUREMENT OF SUBSTITUTE GOODS OR SERVICES; LOSS OF USE, DATA, OR PROFITS; OR BUSINESS INTERRUPTION) HOWEVER CAUSED AND ON ANY THEORY OF LIABILITY, WHETHER IN CONTRACT, STRICT LIABILITY, OR TORT (INCLUDING NEGLIGENCE OR OTHERWISE) ARISING IN ANY WAY OUT OF THE USE OF THIS SOFTWARE, EVEN IF ADVISED OF THE POSSIBILITY OF SUCH DAMAGE.

INDEX

A

Add feed	118
Alarm	100
Alarm list.....	126
Apply change.....	115
Auto Maint.	105

B

Bi-direction adjustment value	82, 120
Bi-directional adjustment	82, 120
Blowing fan	131, 140
Brake Roller.....	120
Browser area	104

C

Cable carrier	32
Capping station	32, 35
Carriage.....	32, 34, 131, 134
Cleaning	101, 105
Clear.....	115
Clear alarm.....	103
Color bar.....	118
Consumables	131, 143
Control PC.....	32, 38, 39, 83, 89, 92, 126, 127, 128
Drop Position Correction	82

D

Daily maintenance	105, 132
Daily station maintenance	105, 132
Delete job	104
Detailed Job Information	94
DISCLAIMERS	5
Document	126
Drop Position Correction	60
Dry feed.....	118
Drying heater.....	101
Drying unit	32, 36
Drying unit Taking out	106

<hr/> E <hr/>	
Ejection failures	79
Emergency stop switch	24, 32
Error List	126
<hr/> F <hr/>	
Feed	101
Feed Comp.	119
Feed Control	120
Feed switch	32
Feeding unit	34
Flushing filter	131
Folder	104
<hr/> H <hr/>	
HDD disk space	126
Head Cleaning	80
Head gap	120
Head maintenance	106
Heater	119
History	100, 125
<hr/> I <hr/>	
Ink	100
INK END	52
Ink lever	34
Ink maintenance	132
INK NEAR-END	52
INK STATUS	100, 102
Ink Supply Unit	32
Ink tank	34
Ink tank calibration	106
Installation Space	22
Interference	5
Internal pattern	79, 119
<hr/> J <hr/>	
Jam sensor	131, 138
Job	38, 83, 89
Job history	104
Job import	92, 104
Job Information	94

Job status area	104
Jobs	87, 88, 93, 104
JOG button	32

L

LAN cable	38
Languages	120
License	126
Lifter	30
Light Curtain	32, 35
Local network	39, 83
Log collection	126
Logical Seek	118

M

Machine information	126
Machine setting	94
Main power supply	127
Main power switch	32, 127, 128
Maintenance	100, 105
Maintenance mode	37
Maintenance Switch	32
MAPS	94, 119
Media	62, 77, 120
Media origin	120
MENU	100
MIST FILTER	144
Moisture tray	35, 131, 136
Moisture tray maintenance	106
MPC	38, 100, 104
MPC user's guide	126

N

Network setting	120
Nozzle check tool	105
Nozzle illustration	115
Nozzle Recovery	105
Nozzle recovery table	115
Nozzle recovery table filter	115
Nozzle Recovery	105

O

Operation manual.....	126
Origin shift	79, 119
Origin shift margin	79, 119
Other maintenance.....	106
Over print.....	94

P

Pass	94
Pause	95, 104
Platen	35, 131, 139
Power	126
Powerful Cleaning	105
Pre feed.....	118
Print	118
Print conditions/settings	104
Print direction	94
Print head	77
Print menu	100, 104
Print mode.....	37
Print origin	95
Print origin X.....	94
Print origin Y.....	94
PRINTER STATUS.....	100, 101
Purified water tank.....	30, 32
Purified water tank calibration	106

Q

Queued jobs	104
QUICK MENU.....	101

R

Reboot System.....	126
Refresh.....	118
Removable disk.....	89
Replace ink filter.....	106
Replace parts	106, 143
Replace Wiper	106
Replace Wiper	143
Reset machine	126
Resume	95, 104
RIP PC.....	30
RIP software	38

Rotation direction switch 33

S

Scan speed 94

Scroll buttons 115

Select head 118

Serial number 84, 88

Service maintenance mode 126

Set media 120

Setting 1 79, 100, 118

Setting 2 77, 82, 100, 120

Shutdown system 127

Signal tower 32

Signal tower light 36

Stop 95, 104

Symbols 6

SYSTEM ALARM 100, 102

System information 45, 84, 88, 126

System menu 101, 126

System setting 120

T

Table 32

Take-up Unit 34

Tension bar 101

Tension bar initializing switch 32

Test pattern 104

Test printing 101

Touch panel 32

TxLink 45

V

Vacuum 101

Version 126

W

Warning labels 25

Waste ink tank 30, 32, 131, 142

Weekly maintenance 106, 135

Weekly station maintenance 106, 135

Winding unit 32

Wiper 131, 132, 143

Wiper unit	131
<hr/>	
X	
<hr/>	
X drive roller	131
<hr/>	
Y	
<hr/>	
Y-bar.....	32

Operation manual

September, 2023

MIMAKI ENGINEERING CO.,LTD.

2182-3 Shigeno-otsu, Tomi-shi, Nagano 389-0512 JAPAN

D203673-11-15092023

