

USER'S MANUAL

TCMX SERIES

How to perform embroidery

1. To turn ON the power	36
2. Setting of the fabric, passing of the thread	38
3. Registration of a design into the machine memory	43
4. Decision of an embroidery design and the color change sequence ...	50
5. Decision of the design start position	60
6. Check items before embroidering.....	67
7. Embroidery starts	72

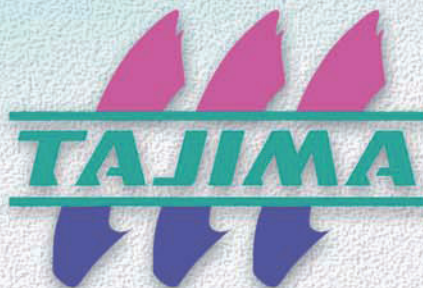

Foreword

This user's manual describes about the correct using method and instructions for use of this product. Please use this machine after understanding the contents of the manual.

This manual may contain discrepancies in detailed specifications as compared with the actual production model. If you have any questions about this manual, consult your TAJIMA distributor.

We believe that "BASICS TAJIMA EMBROIDERY MACHINES" and "MACHINE SETUP INSTRUCTIONS" are useful to deepen your knowledge about this product. Please also read those booklets.

Regarding how to handle the products related, refer to the user s manual exclusive for them included in the manual CD.

TISM Co.,Ltd.

SAFETY PRECAUTIONS

To prevent any harm or damage to the person who use this product or other person, we describe items that must be surely followed as below.



Indicates that there is a lot of danger of death or serious injuries [*1] if handled by mistake.



Indicates that there is a likelihood of death or serious injuries [*1] if handled by mistake.





Indicates a potentially hazardous situation which may result in minor or moderate injury [*2] or property damage if handled by mistake.

*1: A condition caused by electric shock, injury, fracture of a bone, etc., that leads to aftereffects, or an injury that necessitates hospitalization or visits to a hospital over a long period.

*2: An injury that does not necessitate hospitalization or visit to a hospital over a long period.

 : Prohibited items

 : Items that may cause electric shock if not observed

 : Items that must be followed carefully to ensure safe operation

Chapter 1 Items that must be followed carefully

- 1.** Safety Precautions 2
 - 1-1.** Warning 2
 - 1-2.** Caution 4
- 2.** Warning labels 6
 - 2-1.** TCMX-mixed type, TCMX-600 6
 - 2-2.** TCMX-mixed type (L) 7
 - 2-3.** TCMX-601 7
- 3.** Inspection before starting work 8

Chapter 2 Name and way to use of each part

- 1.** Name of each part 10
 - 1-1.** TCMX-mixed type series 10
 - 1-2.** TCMX-600 series 12
- 2.** How to use each part 14
 - 2-1.** Operation panel 14
 - 2-2.** Emergency stop switch 18
 - 2-3.** Table offset switch 19
 - 2-4.** Sleep mode key 20
 - 2-5.** Color change device (TCMX-mixed type series only) 20
 - 2-6.** Jog remote-controller (Option for some models) 21
- 3.** Chenille stitches 22
 - 3-1.** Sewing method 22
 - 3-2.** Needle for chenille stitch 23
 - 3-3.** Looper 23
 - 3-4.** Combination of needle, nipple and needle plate 24
 - 3-5.** Optional device of CM head 25

Chapter 3 Screen

1.	Screen display.....	28
1-1.	Main screen.....	28
1-2.	List screen.....	30
1-3.	Setting screen.....	30
1-4.	Character/numeric value input screen.....	30
1-5.	Design confirmation screen.....	31
2.	Message display.....	33
2-1.	Condition data.....	33
2-2.	Start point of design.....	34
2-3.	Offset Return.....	34

Chapter 4 How to perform embroidery

1.	To turn ON the power.....	36
1-1.	Power switch.....	36
1-2.	To turn ON the power.....	37
2.	Setting of the fabric, passing of the thread.....	38
2-1.	To set fabric.....	38
2-2.	Thread passing.....	38
3.	Registration of a design into the machine memory.....	43
3-1.	To use USB memory (Data Input USB).....	43
3-2.	To use personal computer (Data Input LAN).....	46
4.	Decision of an embroidery design and the color change sequence.....	50
4-1.	To decide embroidery design (Data Setting).....	50
4-2.	To decide order of embroidery type (Auto Stitch Type Selection).....	53
4-3.	To change color automatically / to start operation automatically (Auto Color Change "AC" / Auto Start "AS").....	57
5.	Decision of the design start position.....	60
5-1.	To check design size and setting contents of design (Check of design).....	60
5-2.	To lower needle bar to adjust frame position (Needle bar operation).....	61
5-3.	To move frame to the design start position (Manual frame travel).....	62
5-4.	To check if design fits in embroidery space (Trace).....	65

Contents

- 6. Check items before embroidering..... 67
 - 6-1. Maximum speed (Maximum RPM) 67
 - 6-2. Embroidery head 69
- 7. Embroidery starts 72
 - 7-1. Start and stop 72
 - 7-2. Frame Back (to return the frame) / Frame Forward (to advance the frame) 73
 - 7-3. Handling of thread breakage 78
 - 7-4. Completion of embroidery 82

Chapter 5 Functions concerning CM head

- 1. Related to needle and looper 84
 - 1-1. To change the needle height temporarily (Manual Needle Height Selection) 84
 - 1-2. To return D-axis and the looper to the origin (D-axis Origin Return) 85
 - 1-3. To return the looper to the fixed position (Looper Fixed Position Return) 86
 - 1-4. To move up/down the needle and the nipple manually 87
- 2. Related to stitching 88
 - 2-1. To change stitch type temporarily (Manual Stitch Type Selection)..... 88
 - 2-2. Setting to prevent a fray of the thread (Number of Tie Stitches) 89
 - 2-3. Setting to prevent a fray of the thread (Thread Management After Trimming)..... 90
 - 2-4. Frame Back Function (TCMX-601)..... 91
 - 2-5. Frame Back Function (TCMX-600 with 2 or more heads, TCMX-Mix series) 92
- 3. M-axis of MT-1 (Bobbin) (Option) 93
 - 3-1. To rotate M-axis by manual operation 93
 - 3-2. To return M-axis to the origin by manual operation (Manual M-axis Origin Return).... 94
 - 3-3. To return M-axis to the previous position by manual operation
(Manual M-axis Power-ON Restore)..... 95
 - 3-4. To set stand-by position of M-axis (M-axis Origin Offset)..... 96
 - 3-5. To set M-axis Retract Position (M-axis Retract Position) 97
 - 3-6. To return M-axis to the stand-by position after data set
(M-axis Origin Search at Data Setting) 98
 - 3-7. To return M-axis to the previous position when the power is turned ON
(Auto M-axis Power-ON Restore) 99

Chapter 6 Functions concerning embroidery

1.	To perform color change, to switch head	102
1-1.	To perform color change manually, to change stitch type (Manual Color Change) .	102
1-2.	To switch CM head, FM head manually (Manual Head Selection)	103
2.	To trim thread	104
2-1.	To trim thread manually (Manual Thread Trimming).....	104
2-2.	To trim thread automatically (FM head)	105
2-3.	To change thread breakage detecting sensitivity (FM head)	108
2-4.	To change thread breakage detecting sensitivity (CM head).....	110
2-5.	To trim thread by the number of consecutive jump stitches (Jump Convert)	111
2-6.	To add thread trimming code to the design and trim thread (Data Edit "Insert").....	112
3.	To set the embroidery speed.....	115
3-1.	To limit embroidery speed by stitch length (Minimum RPM) (FM head)	115
3-2.	To decide upper limit value of the maximum speed (Max. Revolution Limit) (FM head)	116
3-3.	To decide upper limit value of the maximum speed (Max. Revolution Limit)	117
4.	To stop the machine.....	118
4-1.	To stop the machine automatically when reaching the set value (Preset Halt).....	118
4-2.	To stop the machine with the needle bar stuck in the material (Stop at Lower D.Point).....	119
5.	To change the direction and the size of the design.....	120
5-1.	To perform enlargement, rotation, reversion (Data Conversion).....	120
6.	To embroider the same design repeatedly.....	122
6-1.	To repeat to horizontal and vertical direction (Repeat)	122
6-2.	To repeat at the same place (A.S. after Auto Data Set).....	125
7.	To adjust finishing of embroidering	126
7-1.	To adjust driving error of the frame (Backlash) (FM head).....	126
7-2.	To adjust stitch length of Satin Stitch (Satin Stitch) (FM head).....	127
7-3.	To divide a long stitch (Auto Jump) (FM head)	129
7-4.	To change embroidering condition in every needle bar (Setting in Units of Needle Bar) (FM head)	130

Contents

7-5.	To delete tiny stitch (Cleanup).....	132
7-6.	To change thread tension (Frame Start Timing).....	133
7-7.	To make a remaining upper thread inconspicuous (Upper Thread Lock Timing) (FM head)	135
7-8.	To adjust stitching length according to a stitch length (Frame Drive Adjustment).....	136
8.	To increase embroidering efficiency.....	138
8-1.	To change the number of lowering needle bar at slow operation (Main Shaft Inching) (FM head)	138
8-2.	To collect up frame moving amount of consecutive jump stitches in a batch to feed the frame all at once (Jump code combination) (FM head).....	138
8-3.	To change moving speed of the needle bar case (Color change speed) (FM head)	139
8-4.	To change travel speed of the frame (Frame Travel Speed).....	140
9.	To edit design	141
9-1.	To modify the stitch (Data Edit "Modify")	141
9-2.	To insert the stitch (Data Edit "Insert")	144
9-3.	To delete the stitch (Data Edit "Delete")	148
10.	Setting and resetting of password	151
10-1.	To change password (Functional Limit of Password).....	151
10-2.	To cancel the password.....	153
11.	Various functions	154
11-1.	To check the number of total stitches up to now (Total Stitch Counter)	154
11-2.	To color in every needle bar (Needle Bar Color)	155
11-3.	To check version of current software (Software Version).....	156
11-4.	To switch display language (Language).....	157
11-5.	To release fixing of main shaft motor (weak brake).....	158
11-6.	To lower the needle bar by manual operation (Manual Stop at Lower Dead Point)..	159

Chapter 7 Functions concerning frame movement

1.	To return the frame (Frame Back) / to advance the frame (Frame Forward).....	162
1-1.	To switch Frame Back / Frame Forward	162
1-2.	To execute by Stop code, to specify number of stitches to execute	163
1-3.	To change a frame feed amount of frame back / frame forward	165
1-4.	To set All Head Sewing Start Point (Frame Back All head Sew) (FM head).....	166
2.	Necessary works after replacing the frame	168
2-1.	To change frame type	168
3.	To return the frame to the original position.....	169
3-1.	To return the moved frame to the previous position (Manual Offset).....	169
3-2.	To return moved frame to original position and start operation (Return the frame after manual frame travel)	170
3-3.	To prevent displacement of design when the power is shut off during operation (Power resume).....	171
3-4.	To memorize frame origin (Frame origin memory).....	172
4.	To return the frame to the design start position.....	174
4-1.	To return the frame to the design start position manually (Return to the design start position)	174
4-2.	To return the frame to the design start position automatically (Auto Origin Return)	175
5.	To move the frame to the position registered.....	176
5-1.	To move the frame automatically at the start and the end of embroidery (Automatic Offset).....	176
5-2.	To move the frame automatically at the start, in the middle and the end of embroidery	178
5-3.	To return the frame to the offset start position manually (Return to the offset origin).....	180
6.	To register frame position.....	181
6-1.	To register the frame position to make threading easily (table offset position)	181

Chapter 8 Function concerning storing and deleting of design

- 1.** Design stored in the machine memory 184
 - 1-1.** To delete a design (Memory Delete) 184
 - 1-2.** To move a design (Movement of design) 185
 - 1-3.** To copy a design (Copy a design)..... 186
 - 1-4.** To change the file name of the design (Changing design name) 188
 - 1-5.** To change a folder name (Changing folder name)..... 190
 - 1-6.** To sort a design (Design sort "in memory")..... 192
 - 1-7.** To store a design to a USB memory (USB "Save")..... 194
- 2.** Design saved in USB memory..... 196
 - 2-1.** To delete a design (USB Delete)..... 196
 - 2-2.** To sort a design (Design sort "USB") 198

Chapter 9 Setting for optional device

- 1.** To make optional device available for use 202
 - 1-1.** Sequin Device (common to IV and ESQ-C) 202
 - 1-2.** Seed Beads Device (FM head) 203
 - 1-3.** Automatic Lubrication System (FM head) 205
 - 1-4.** Network 206
 - 1-5.** Lochrose embroidery device (FM head)..... 207
 - 1-6.** Cording device (FM head) 209
 - 1-7.** Boring device II (FM head) 210
 - 1-8.** Bobbin changer (FM head)..... 212
 - 1-9.** MT-1 (Coiling) (CM head)..... 213
 - 1-10.** KT-1 (Taping) (CM head) 214
- 2.** To set details of optional device 215
 - 2-1.** ESQ-C (FM head)..... 215
 - 2-2.** Sequin Device IV (FM head) 218

3.	Functions concerning optional device.....	221
3-1.	To make the air compressor available for use (Air Pressure Sensor)	221
3-2.	To reverse the 1st color and the 2nd color in ESQ-C (Data conversion for sequin output).....	222
3-3.	To change color by using DST design in ESQ-C (Auto Stitch Type Selection)	224
3-4.	Lochrose counter	226

Chapter 10 Countermeasure when some trouble occurs in the machine

1.	Countermeasure when the machine stopped	228
1-1.	Normal stop	228
1-2.	Abnormal stop.....	229
1-3.	Stop due to malfunction	232
2.	Trouble examples and Corrective actions (CM head)	236
2-1.	The machine does not sew well.....	236
2-2.	Needle breaks.....	236
2-3.	Needle hooking on the fabric	237
2-4.	Thread cast-off, mis-stitching.....	237
2-5.	To suspend the head with occurrence of error	237
2-6.	To excite the motor	239
3.	Trouble examples and Corrective actions (FM head).....	240
3-1.	Thread breakage is highly visible.	240
3-2.	Needle breaks.....	241
3-3.	Bad finishing of embroidering	241
3-4.	To suspend the head with occurrence of error	242

Chapter 11 Maintenance and Inspection





- 1.** Items that must be followed carefully 244
- 2.** Cleaning 246
- 3.** Lubrication 249
- 4.** Greasing 253
- 5.** Inspection, Repair 257
- 6.** Adjustment of the middle thread guide 258
 - 6-1.** Snap-fit middle thread guide (for regular rotary hook machine) 258
 - 6-2.** One-touch middle thread guide (for jumbo rotary hook machine) 261



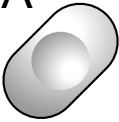
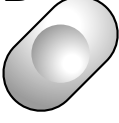
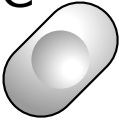
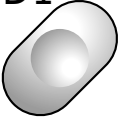
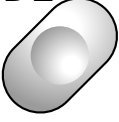

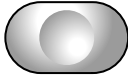

Chapter 12 Appendix

- 1.** Specification of the machine 264
 - 1-1.** Power supply specifications 264
 - 1-2.** Ambient noise level 265
 - 1-3.** Machine weight 265
 - 1-4.** Switching of input voltage 266
- 2.** Function code 268
- 3.** Electrical system diagram (TCMX-mixed type series) 269
 - 3-1.** TCMX-mixed type, TCMX-mixed type (L) 269
- 4.** Electrical system diagram (TCMX-600 series) 271
 - 4-1.** TCMX-601 271
 - 4-2.** TCMX-600 272
- 5.** Terminology 274

For the software installation method, refer to the separate "SYSTEM HANDLING MANUAL".

Menu key	Title	Operation in the middle of embroidery Able ○/Unable ×
A 	1 Data Input (Memory)50	○
	4 Data Input (USB).....43	○
	5 Data Input (LAN)46	○
	8 Memory Delete.....184	○
B 	1 Auto Color Change (AC) / Auto Start (AS)57	○
	2 Auto Stitch Type Selection53	○
	3 Data Conversion120	×
	4 Repeat.....122	×
	5 Automatic offset176	×
	6 Automatic Start after Automatic Data Set125	○
	10 Needle Bar Color.....155	○
C 	1 Maximum RPM.....67	○
	2 Total Stitch Counter / Design Timer154	○
	3 Frame Back/Frame Forward162	○
	5 Frame Back All Head Sew166	○
	6 Preset Halt118	○
	7 Frame type168	×
	10 Stop at Lower D. Point119	○
D1 	1 Trace65	×
	2 Manual Color Change102	○
	3 Manual Thread Trimming104	○
	4 Return to the design start position174	○
	5 Manual Offset.....169	○
	6 Return to the offset origin.....180	○
	8 Manual Stop at Lower D.Point159	○
	10 Needle bar operation.....61	○
D2 	1 Manual device - Up/Down --- Refer to the manual for the optional device.	Sequin device IV, ESQ-C, Lochrose embroidery device

F1 	1 Jump Convert.....111	○
	2 Auto Jump129	○
	3 Satin Stitch127	○
	4 Backlash.....126	○
	5 Jump Code Combination.....138	○
F2 	1 Min. Revolution115	○
	2 Revolution Limit.....116	○
	3 Main Shaft Inching138	○
	4 Automatic Origin Return175	○
	5 Frame Travel Speed140	○
	6 Thread Detection.....108	○
	7 Thread Detection (CM).....110	○
	9 ATH105	○
	10 Upper thread lock timing135	○
	F3 	1 Boring.....210
2 Sequin215 (ESQ-C)		○
2 Sequin218 (Sequin Device IV)		
3 Cording.....209		×
6 Lubrication.....205		○
9 Bobbin Changer212		○
10 Lochrose embroidery device207		×
F4 	1 Manual M-axis Origin Return/-----94	○
	1-----/Manual M-axis Power-ON Restore95	○
	2 M-axis Origin Offset96	○
	3 M-axis Retract Position97	○
F5 	1 Manual Head Selection103	○
	2 Manual Needle Height Selection84	○
	3 Manual Stitch Type Selection.....88	○
	4 D-axis Origin Return.....85	○
	5 Looper Fixed Position Return.....86	○
	6 Setting for Number of Tie Stitches89	○
	7 Thread Management After Trimming90	○
	8 Frame Back Function91	○
	10 Taping214	○

F6 	6 Coiling Setting 213	○
	 	1 Data Edit 141 (Modification)
 	1 Data Edit 144 (Insertion)	○
	1 Data Edit 148 (Deletion)	○
	2 Cleanup..... 132	○
	4 Move a design..... 185	○
	5 Copy a design 186	○
	6 Changing design name 188	○
	7 Changing folder name..... 190	○
	9 Data conversion for sequin output 222	○
 	6 USB (Save)..... 194	○
	7 USB (Delete)..... 196	○
SET+A	1 Design sort (in memory)..... 192	○
	4 Design sort (USB)..... 198	○
SET+F1	1 Password (Functional Limit)..... 151	○
	3 Setting in units of Needle bar 130	○
SET+F2	1 Max. Revolution Limit..... 117	○
	2 Frame Start Timing 133	○
	3 Frame Drive Adjustment 136	○
	5 Table Offset Position..... 181	×
	6 Return the frame after manual frame travel 170	○
	8 Power Resume 171	○
	9 Frame Origin Memory 172	×
SET+F3	2 Weak Brake 158	○
	3 Air Pressure Sensor..... 221	○
	4 Motor Excitation 239	○
	7 Sequin device 202	×
	10 Network..... 206	○
	14 Seed Beads Device 203	×

To search from the menu key

SET+F4	3 Machine Type	Refer to the separate "SYSTEM HANDLING MANUAL".
	4 Machine Number	
	5 Machine Information	
	8 Software Version 156	○
	10 Language 157	○
SET+F6	1 M-axis Origin Search at Data Setting 98	○
	2 Auto M-axis Power-ON Restore 99	○
PW+F5	2 Color Change Speed 139	○
	10 Cut off Head Control 237	○

Chapter 1

Items that must be followed carefully















1. Safety Precautions.....	2
2. Warning labels	6
3. Inspection before starting work.....	8

1. Safety Precautions

1-1. Warning

When operating the machine, the following items must be observed strictly to prevent accidents resulting in injury or death.

WARNING

-  This machine is designed for industrial use. Use this machine for semi- or finished textile products and similar materials. Using the machine for other purposes must be avoided.
-  Do not stand on the machine.
-  Using the bar switch as a grip to support yourself is strictly prohibited.
-  Do not use a device such as a cellular phone that generates microwave near the control circuits of the power supply box, the operation panel box, etc. Microwave may cause malfunctioning of the machine.
-  Do not remove the covers for the shaft and the pulleys. Also, do not run the machine without the covers.
-  Do not have your hands, etc. access to the vicinity of needle during operation. Sticking of needle could injure you.
-  During operation, do not access your hands and/or face to moving sections. Especially, it is dangerous around needle, rotary hook, take-up lever, pulley and speed-reduction box.
-  This machine uses strong magnet. The person, who is mounted with internal implantable medical electronics like a pacemaker, should not use this machine. The person who is mounted with a equipment described above also should not access to magnet inside of this machine. This internal equipment could malfunction.
-  Please read this book thoroughly and understand the contents of operation certainly. Then, operate the machine.
-  Wear proper clothes and tidy up yourself so that you can smoothly perform the operation.
-  A single operator should operate the machine in principle. If plural operators are working together, make sure that no one is working near the moving units of the machine before starting the machine.
-  Use the machine under the environment where access can be supervised so that unauthorized person does not operate the machine. Supervise children so that they do not access to the machine.
-  Only the persons who are sufficiently trained for the operation must operate the machine.
-  The rear of the machine is not a working area. If you have to move to the rear of the machine, make sure to turn off the main switch.

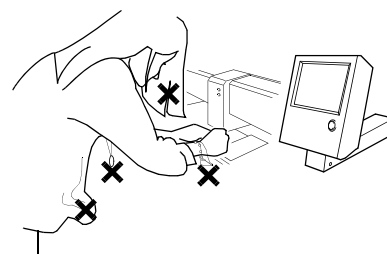
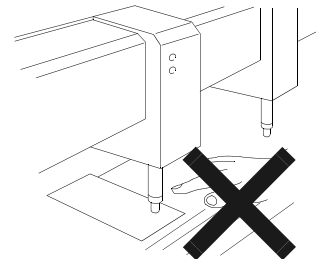

WARNING

- ❗ Stop the machine before threading into the needle and checking the finish of embroidery.
- ❗ For the machine model with the sub table, lift up and fix the sub table securely after threading and/or adjusting the machine.
- ⚠ Do not damage, modify or heat the power or other cables. Do not exert undue force to them, either. Otherwise the cables will be damaged causing fire and electric shock.
- ⚠ Insert the power cable plug fully. If a metallic part touches a blade in the plug, it may cause fire and/or electric shock.
- ⚠ Keep away electrical units from water and chemicals. Entry or splashing of them into electrical units leads to short circuits, causing fire, electric shock and other troubles. If water or other chemicals enter the unit, Turn off the power switch, shut off the primary power of the machine and contact your local distributor.

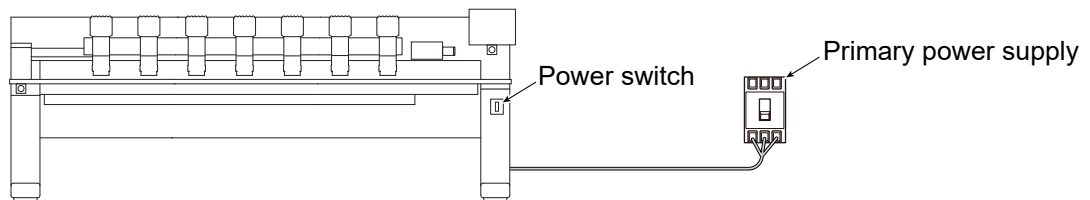

- ⚠ Before opening the electrical boxes, be sure to turn off the power switch of the machine and shut off the primary power. If not, it may cause electric shock.

1-2. Caution

When operating the machine, the following items must be observed strictly to prevent accidents resulting in injury or death and property damage.

CAUTION

- ❗ Use the machine with about 70% of the maximum speed as "operation for total fitting" for about one week after installing this machine. By performing operation for total fitting, life of the machine will become longer, which will be useful to avoid unexpected troubles.
- ⊘ Do not use bent needles or needles that are not suitable for the material. Be sure to turn OFF the power switch after working, and turn OFF the primary power supply.
- ⊘ Do not put things on the machine table.
- ⊘ This machine uses strong magnet. This machine including magnet should not be accessed to a cellular phone, an analogue watch, a floppy disk, a magnetic card, a magnetic tape or a magnetic ticket.

In addition to full-time leak current, leak electric current generated by harmonics and surge flows in the power cable of the machine. For this reason, if selection and installation of breaker of leak current and leak current relay used for the factory are not correct, malfunctioning of the machine may occur.

Regarding connection of power cord, observe the following items.

- ❗ Use a breaker of electric current leakage and leak current relay for which measures are taken against harmonics and surge. If you use conventional breaker and relay without such measures, select with sufficient leak current capacity to fill up leak current by harmonics and surge. (In this case, leak current must be controlled constantly satisfactorily.)
- ❗ Regarding capacity of electric current leakage for leakage breaker and leak current relay necessary per machine, consult your local TAJIMA distributor.
- ❗ For actual product names of breaker of electric current leakage and leak current relay for which measures are taken against harmonics and surge, please consult your local TAJIMA distributor or electric engineers.
- ❗ To prevent the machine from property damages (the power decline of the main shaft motor, etc., stop position error and its color change error, design displacement, etc), one embroidery machine should be connected to one no fuse breaker in regard to connecting power harness.

! CAUTION

- ! Prevent the operation noise in the environment.

This machine is designed to reduce noise during operation. To improve the sound insulation performance in a factory still more, use the interior finish materials which show high sound insulating performance for the walls, ceiling, and floor of the factory.

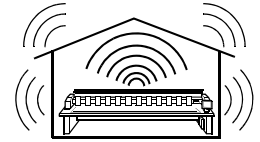

- ! Install the machine on a sturdy floor.

The floor structure must be strong enough to bear the machine weight (indicated on the spec. plate).

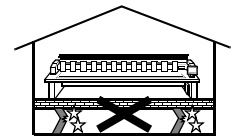

- ! Avoid dust and moisture.

Since dust and moisture lead to dirt and rust on the machine, use the machine in an environment of facility of air conditioner, and clean the working place periodically. Use caution not to expose the machine to direct wind from the air conditioner so that embroidery threads do not become disheveled.

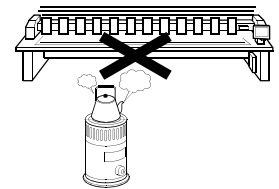

Humidity:

30 to 95% RH (relative humidity) without condensation

Ambient temperature:

5 to 40°C (during operation), -10 to 60°C (during storage)

- ! Avoid direct sunlight.

If the machine is exposed to direct sunlight over an extended period of time, the machine body may be discolored or deformed. Put curtains or shades to the site to prevent the machine from direct sunlight.

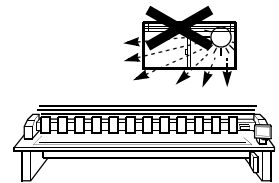

- ! Provide enough space for maintenance.

Taking account of workability when maintaining and inspecting the machine, provide 50 cm or more working area to right, left and rear directions of the machine against obstacles such as walls.

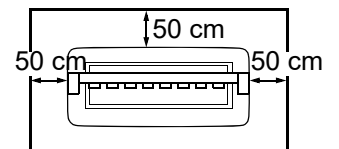

- ! Pay attention to interference of radio wave.

Although the machine is designed not to affect radio wave interference to other equipments, there could be cases where it causes interference depending on operation environment and type of other equipment. If such problems arise, install the equipment with a space from the machine as big as possible.

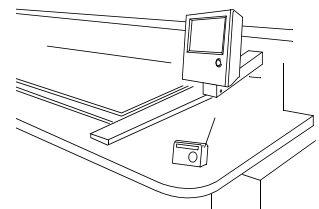

2. Warning labels

The machine has warning labels that bear instructions for safe operation. When using the machine, machine operators must follow the instructions shown on the warning labels.

Do not detach the warning label nor make the printing surface illegible by paint etc. If the warning label is missed or damaged, contact your local distributor.

2-1. TCMX-mixed type, TCMX-600

The figure below is for TCMX-mixed type. Attaching position of warning label for TCMX-600 is also the same as this figure.

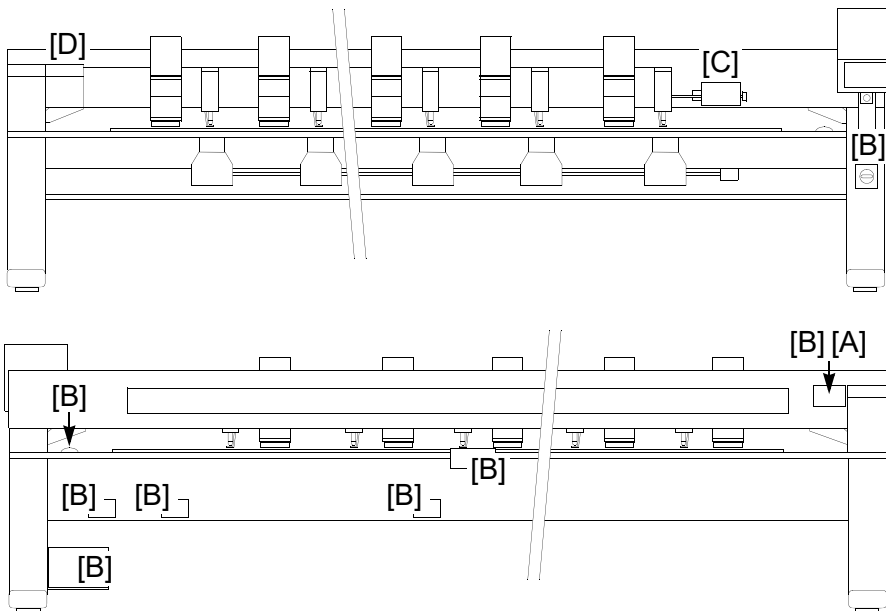

[A] Pay attention not to be caught into the machine.



There could be danger of being caught or clipped. Other persons than the service personnel certified by TAJIMA should not open the cover.

[B] Pay attention to high voltage



There could be danger of electric shock, burning, or death. Persons except for service personnel designated by Tajima should not open covers. When opening covers, wait for four minutes after turning off the power switch.

[C] Pay attention around needle.

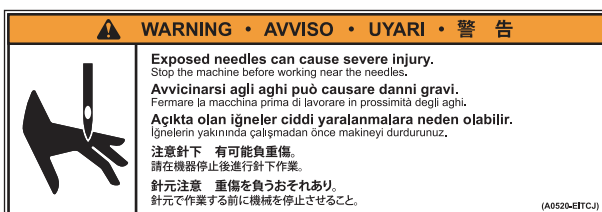

[D] Pay attention not to being caught into the machine.

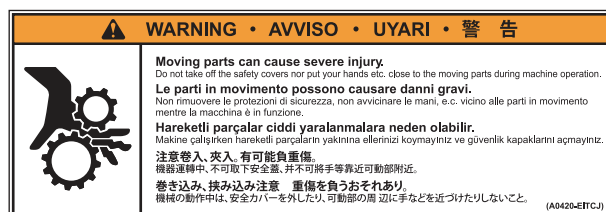

2-2. TCMX-mixed type (L)

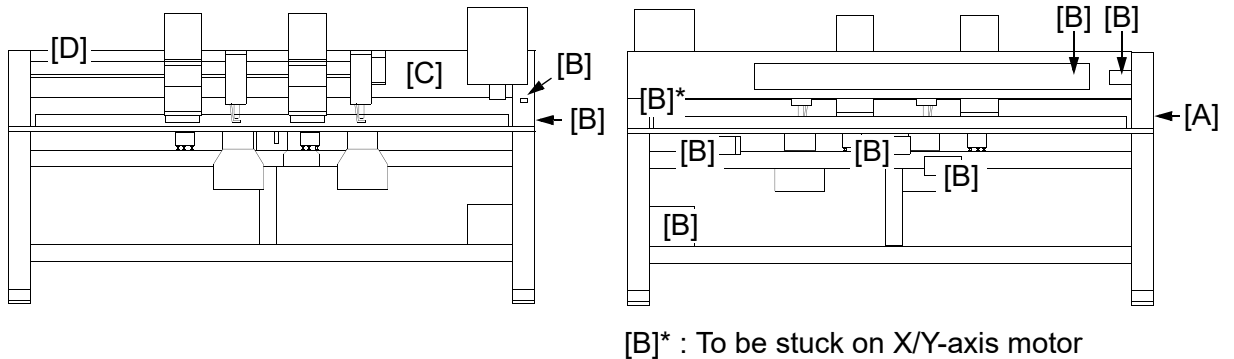

2-3. TCMX-601

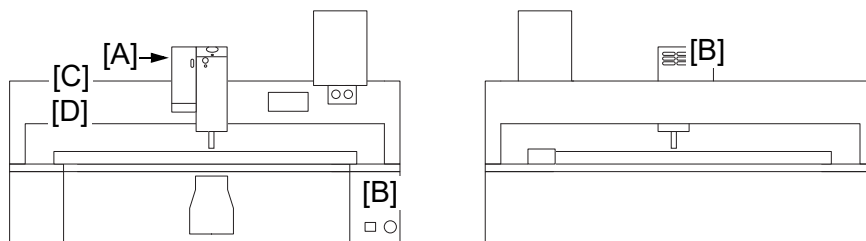

[A] Pay attention not to be caught into the machine.



There could be danger of being caught or clipped. Other persons than the service personnel certified by TAJIMA should not open the cover.

[B] Pay attention to high voltage



There could be danger of electric shock, burning, or death. Persons except for service personnel designated by Tajima should not open covers. When opening covers, wait for four minutes after turning off the power switch.

[C] Pay attention around needle.

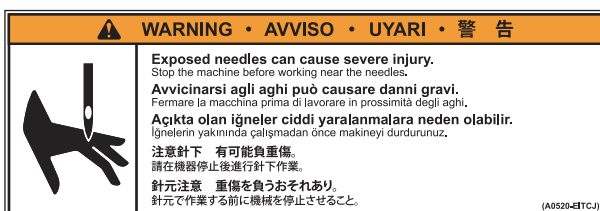

[D] Pay attention not to being caught into the machine.



3. Inspection before starting work

Before starting work, execute inspection (including cleaning, lubrication) of each part.

Place	Checking
Covers	Covers might have been attached incorrectly.
Thread (CM head) Upper thread (FM head)	The thread might have been passed incorrectly to each part. The tension might have been inadequate. The thread might have entwined around frame/drive system.
Under thread (FM head)	The under thread (bobbin case) might have been set to rotary hook incorrectly. The tension might have been inadequate.
Nipple (4 in the figure below)	Does dust adhere to the nipple?
Needle	The needle might have bent. The direction of needle might have been wrong. The needle might have been broken.
Rotary hook(→p.252)	Cleaning/lubrication might have been performed in inadequate frequency.
Tension base switch(→p.70) (1 in the figure below)	The switch of head to use might have been turned ON. The switch of unused head might have been turned OFF.
Needle bar suspension lever(→p.71) (2 in the figure below)	Is the lever of head to use set to ON? Is the lever of unused head set to OFF?
Toggle switch(→p.69) (3 in the figure below)	The switch of head to use might have been turned ON. The switch of unused head might have been turned OFF.
Jog remote-controller(→p.21)	Is it contained in the pocket?

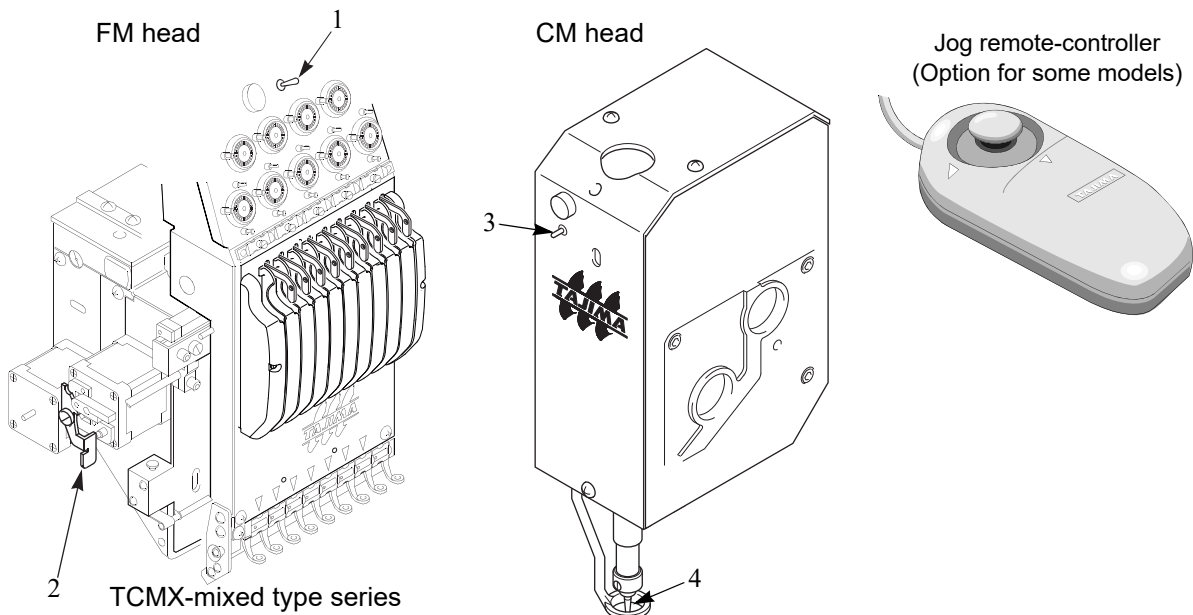

Chapter 2

Name and way to use of each part

1. Name of each part	10
2. How to use each part.....	14
3. Chenille stitches.....	22

1

2

3

4

5

6

7

8

9

10

11

12

1. Name of each part

1-1. TCMX-mixed type series

1-1-1. TCMX-mixed type

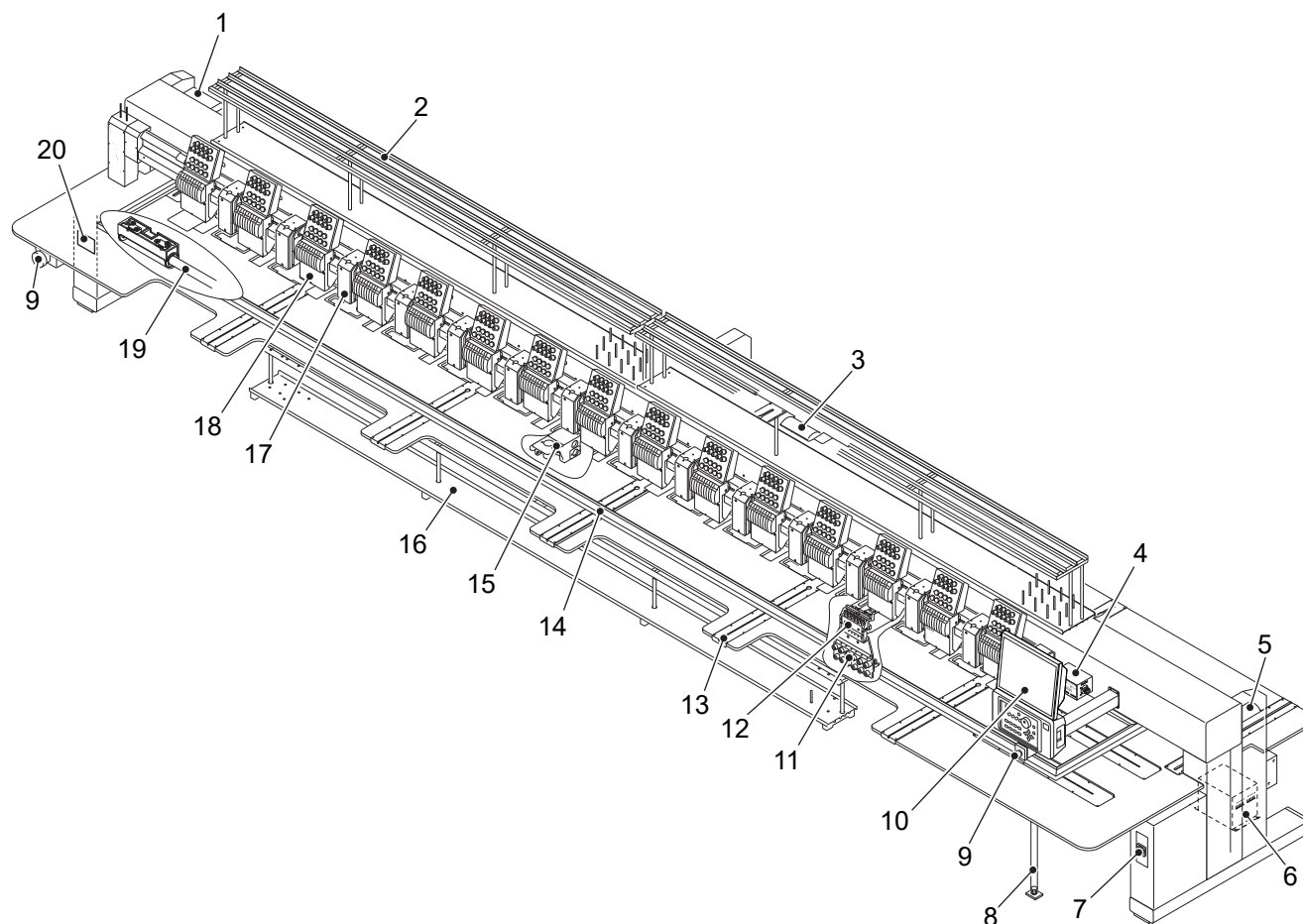

Only main sections are shown here. For details, refer to the separate parts list.

- | | |
|--|---|
| 1. Main shaft motor | 11. Tension base |
| 2. Thread course | 12. Looper base(→p.23) |
| 3. Y-axis motor | 13. Table lid |
| 4. Color change system | 14. Border frame |
| 5. X-axis motor | 15. Rotary hook base |
| 6. Transformer
Existence/absence differs depending on spec. | 16. Thread course (Chenille stitch head) |
| 7. Power switch(→p.36) | 17. Chenille stitch head (CM head)(→p.69) |
| 8. Table support | 18. Normal embroidery head (FM head)(→p.70) |
| 9. Emergency stop switch(→p.18) | 19. Bar switch(→p.72) |
| 10. Operation panel(→p.14) | 20. Spec. plate |

1-1-2. TCMX-mixed type (L)

This model is compact size and it is suitable for sample sewing or small lot production.

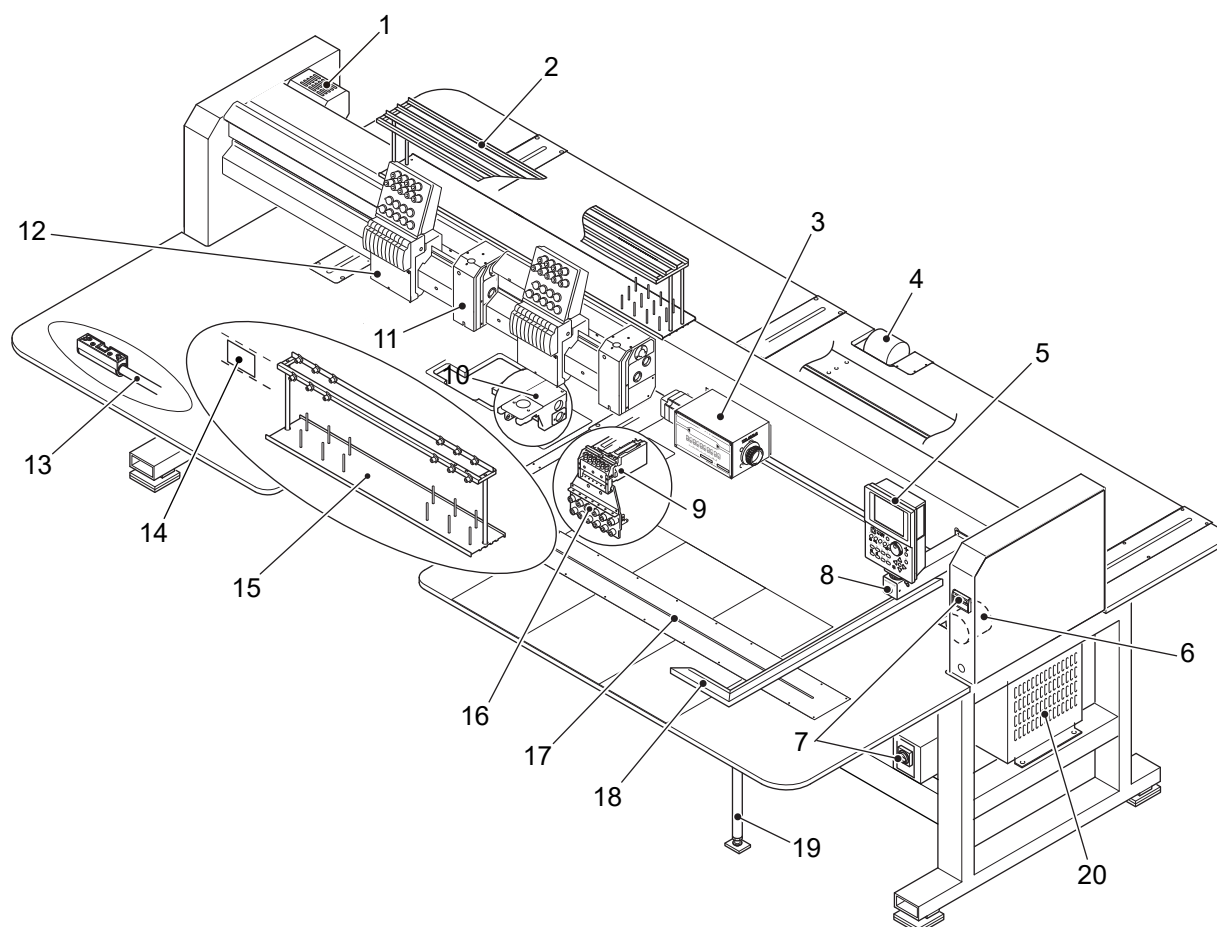

Only main sections are shown here. For details, refer to the separate parts list.

- | | |
|--|--|
| 1. Main shaft motor | 11. Chenille stitch head (CM head)(→p.69) |
| 2. Thread course | 12. Normal embroidery head (FM head)(→p.70) |
| 3. Color change system | 13. Bar switch(→p.72) |
| 4. Y-axis motor | 14. Spec. plate |
| 5. Operation panel(→p.14) | 15. Thread course (Chenille stitch head) |
| 6. X-axis motor | 16. Tension base |
| 7. Power switch(→p.36) | 17. Table lid |
| Either switch is equipped (differs depending on spec.) | 18. Border frame |
| 8. Emergency stop switch(→p.18) | 19. Table support |
| 9. Looper base(→p.23) | 20. Transformer |
| 10. Rotary hook base | Existence/absence differs depending on spec. |

1-2. TCMX-600 series

1-2-1. TCMX-601

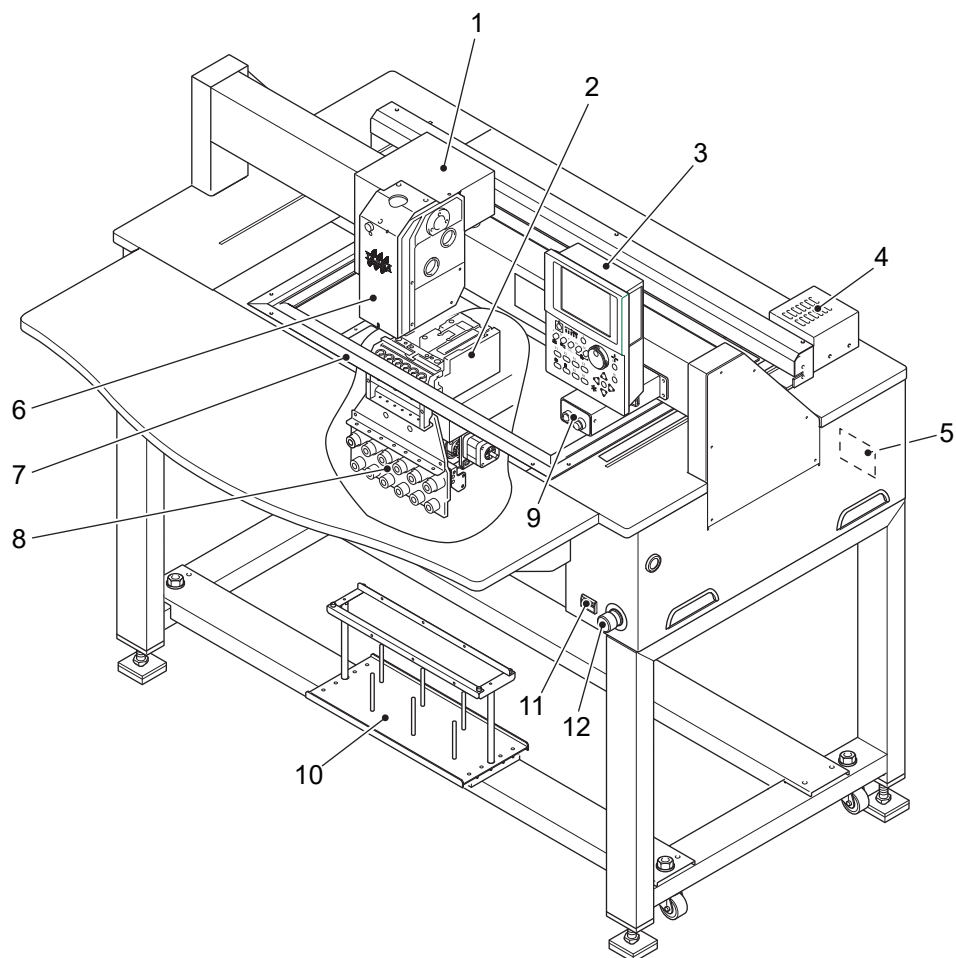

Only main sections are shown here. For details, refer to the separate parts list.

- | | |
|--|----------------------------------|
| 1. Main shaft motor | 7. Border frame |
| 2. Looper base(→p.23) | 8. Tension base |
| 3. Operation panel(→p.14) | 9. Start/stop switch(→p.72) |
| 4. X-axis motor | 10. Thread course |
| 5. Spec. plate | 11. Power switch(→p.36) |
| 6. Chenille stitch head (CM head)(→p.69) | 12. Emergency stop switch(→p.18) |

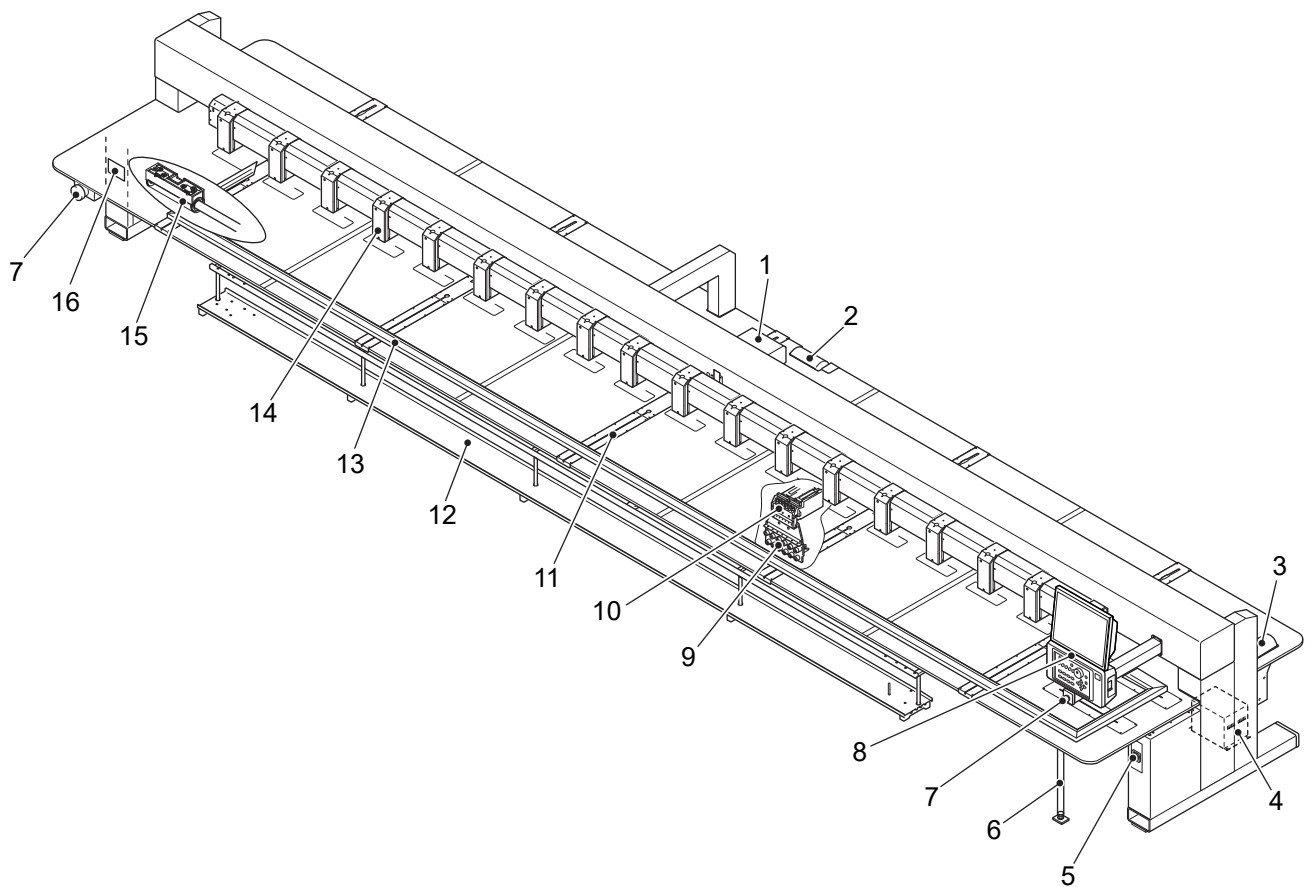
1-2-2. TCMX-600

Only main sections are shown here. For details, refer to the separate parts list.

- | | |
|--|---|
| 1. Main shaft motor | 9. Tension base |
| 2. Y-axis motor | 10. Looper base(→p.23) |
| 3. X-axis motor | 11. Table lid |
| 4. Transformer | 12. Thread course |
| Existence/absence differs depending on spec. | 13. Border frame |
| 5. Power switch(→p.36) | 14. Chenille stitch head (CM head)(→p.69) |
| 6. Table support | 15. Bar switch(→p.72) |
| 7. Emergency stop switch(→p.18) | 16. Spec. plate |
| 8. Operation panel(→p.14) | |

2. How to use each part

2-1. Operation panel

There are two types of operation panels depending on the model.

17-inch spec.

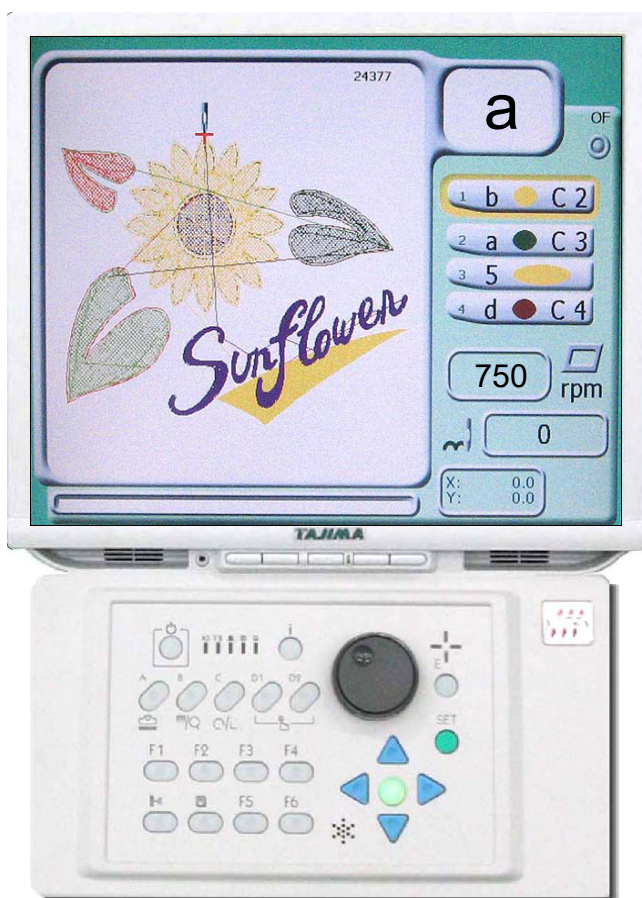

Applicable model
TCMX-mixed type, TCMX-600

6.5-inch spec.



Applicable model
TCMX-mixed type (L), TCMX-601

2-1-1. Front

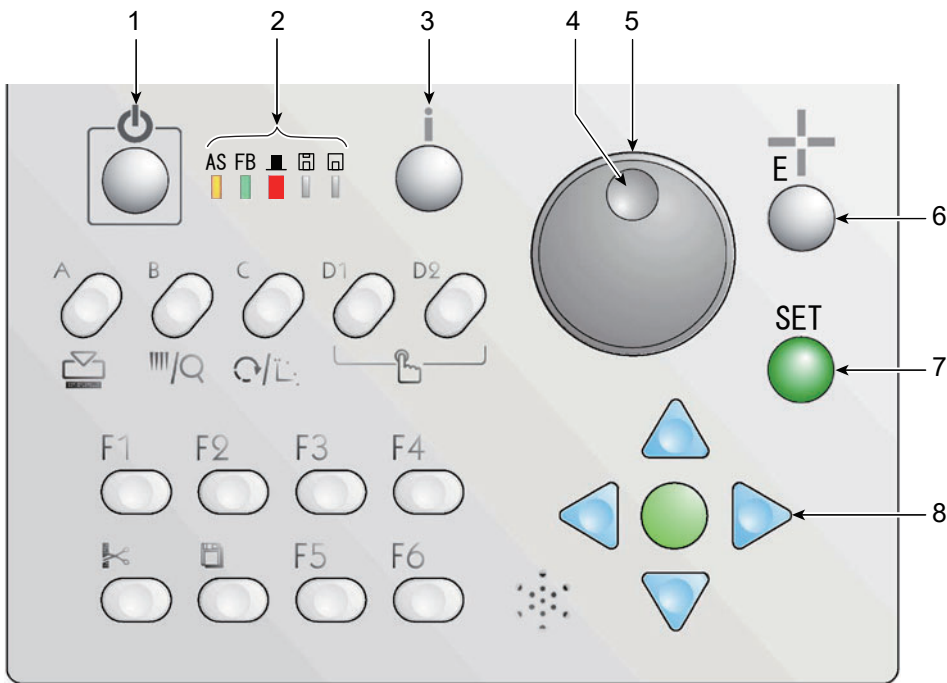

1. Sleep mode key(→p.20)

Switch to power save mode. To release, press this key again.

2. Condition of the machine

AS (Auto Start)

To perform: Lit

Not to perform: Unlit

FB?frame back / forward)(→p.73)

Frame Back: Lit

Frame Forward: Unlit

■(Main shaft stop position)

Fixed position: Lit (normal)

Other than the fixed position: Unlit (abnormal)

Lower dead point, or main shaft brake "NO": Blinking

☐(FDD)

Not used currently

☐(USB port)

During operation: Lit

3. Design confirming mode key (i key in this manual) (→p.31)

It is possible to check the detail of the design to be embroidered from now.

4. Jog dial

Move the frame at low speed.

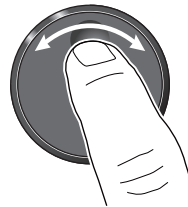

It is illustrated as below in this manual.

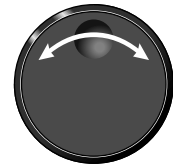

5. Jog shuttle

Move the frame at high speed.

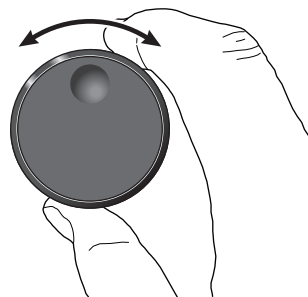

It is illustrated as below in this manual.

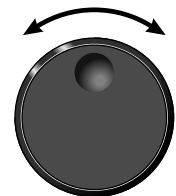

6. Escape key (E key in this manual)

The screen will return to the original screen. Release the stop factor.

7. Set key

Determine the selected value.

8. Frame Travel key(→p.63)

Move the frame manually.

1
2
3
4
5
6
7
8
9
10
11
12

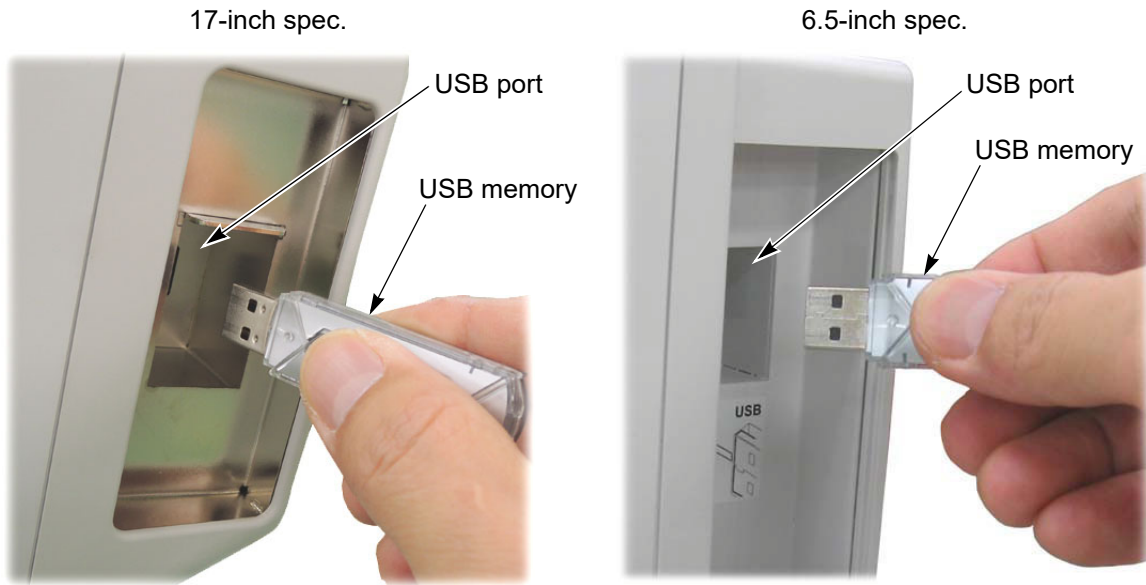
2-1-2. Side**(1) USB port**

There are two spots (side face, rear face). It is not possible to use at these two spots at the same time. USB port is used for the following cases.

- When connecting the USB memory
- When connecting the bar code reader (commercial item)

(2) USB memory

Prepare a commercial item. USB memory is used for the following cases.

- When registering the design (saved in the USB memory) into the machine memory
- When saving the design (saved in the machine memory) into the USB memory
- When installing the software in the machine

Some type and/or capacity of the USB memory could not be used for this machine. In this case, buy the USB memory recommended by Tajima. For details, consult the distributor.

For using the USB memory, observe the items to notice described below.

! CAUTION

- ⊘** Do not turn ON the machine power in the state that the USB memory is connected to the operation panel except when installing the software in the machine. The system sometimes may not start up.
- ⊘** Do not insert in or pull out the USB memory during operation (when the main shaft motor and the frame are moving, or in the middle of color change etc.). Inside circuit board could be damaged.

! CAUTION

- ⊘ When you insert the USB memory, do not mistake the direction of connector. The USB memory and its inside circuit board could be damaged.
- ⊘ Do not insert the USB memory in the state that dirt and dust are attached to the inside of the connector.
- ! Insert the USB memory slowly and gently.
- ! Insert the USB memory upright against the port (insertion slot). Oblique insertion could damage to inside circuit board due to interference of connector with the circuit board.
- ! Wait for five or more seconds after inserting or taking out the USB memory, and then start the operation. It may take about one minute at a maximum to recognize data.

2-1-3. Rear

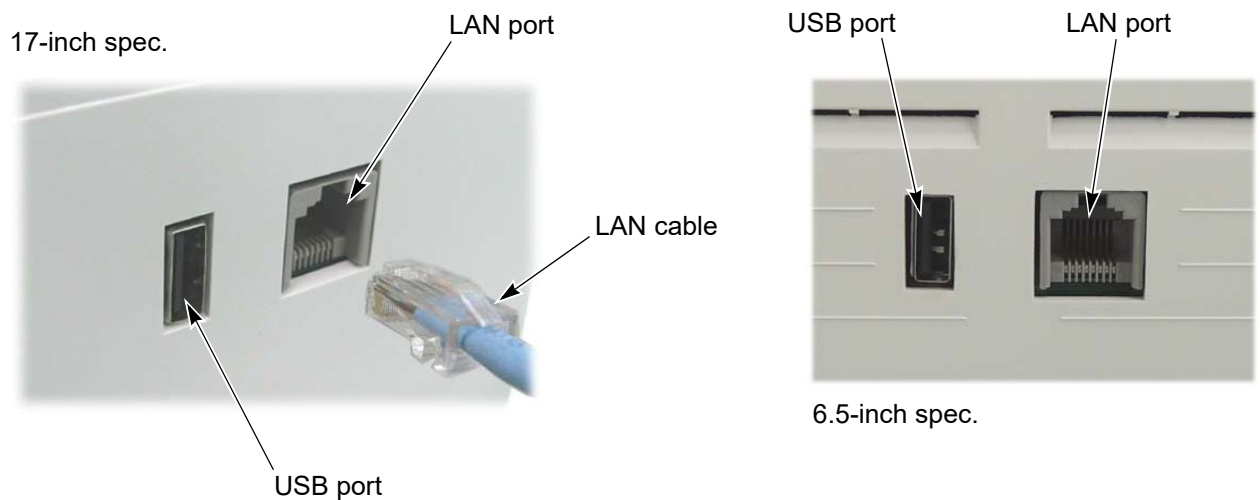

(1) LAN port

Use the LAN port when connecting the LAN cables.

(2) LAN cable

Please prepare a commercial item. LAN cable is used for connecting a personal computer with the machine. Setting of the operation panel is necessary additionally.(→p.206)

(3) USB port

Refer to the explanation of the USB memory at the side face of the operation panel.(→p.16)

2-2. Emergency stop switch

The emergency stop switch is equipped as a measure for safety. Pressing this switch will stop the machine. Since the switch is in the locked state, release it according to the following procedure. After releasing, the operation can be started as usual.

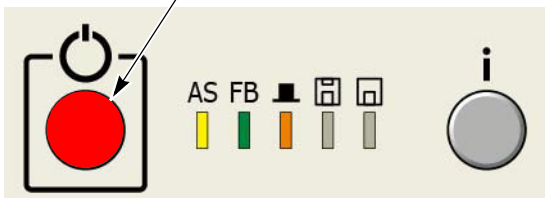

Specification of the machine	Condition after stop	How to release
EN-spec. (European safety spec.)	The power will be turned OFF.	<p>(1) Turn the switch clockwise. (The power will be turned ON.)</p> <p>(2) Start the operation.</p>
Excluding EN-spec., and Japanese domestic use	The machine will switch to the sleep mode.	<p>(1) Turn the switch clockwise.</p> <p>(2) Press the sleep mode key. It takes a while until the sleep mode is released.</p> <div style="text-align: center;">  </div> <p>(3) Start the operation.</p>

2-3. Table offset switch

This operation facilitates threading by moving the frame to the rear (the table offset position) at thread breakage. Pressing this switch will move the frame to the table offset position. This function is supported by the machine equipped with the table offset switch.



Table offset switch

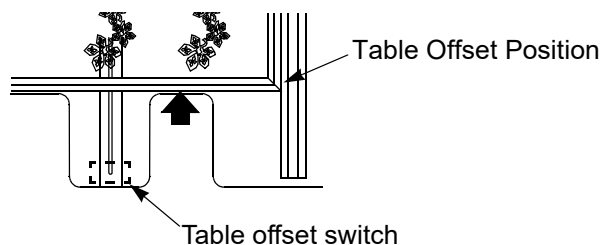

When changing table offset position, refer to the detail page.(→p.181)

CAUTION

⊘ When performing this operation, do not put your hands, etc. on the table. Moving the frame could injure you.

2-3-1. How to operate

The machine stops when thread breaks. Since the movement of the machine differs depending on the switch operation, perform any one of the following operations. The frame moves in the same way even when the thread does not break.

- (1)** Press the switch and release it immediately.

When CM head is selected → After cutting the thread, the frame will move to the rear.

When FM head is selected → The frame will move to the rear.

- (2)** Press the switch for two seconds or more.

→After trimming threads of all heads, the frame will move to the rear.

Since the movement of the machine after passing the thread differs depending on the switch operation, perform any one of the following operations. In case of CM head, perform the following operation after the manual thread trimming. Neglect of the manual thread trimming will cause the sewing thread to be pulled as it is left on the fabric.

- (1)** Press the switch and release it immediately.

→ The frame will return to the original position.

- (2)** Press the start switch, or move the bar switch to the right.

=> The frame will return to the original position and the machine will start operation.

- (3)** Press the stop switch or move the bar switch to the left.

=> The frame will return to the original position and the machine will perform frame back/forward.

(→p.73)

2-4. Sleep mode key

Setting the machine to sleep mode at intermission etc. will suppress unnecessary power consumption.

2-4-1. How to switch to the sleep mode

- (1) Set to the main screen.
- (2) Press the sleep mode key for a few seconds. The sleep mode key is blinking in red.

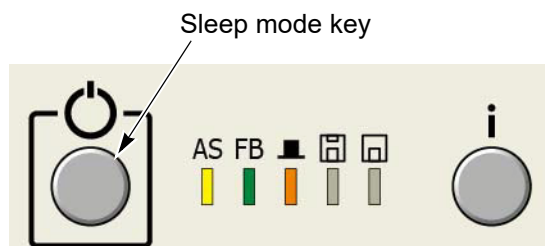

2-4-2. How to cancel the sleep mode

Press the sleep mode key. The sleep mode key is unlit.

2-5. Color change device (TCMX-mixed type series only)

It is possible to check the needle bar No. being selected at present.



An example when the 2nd needle
of FM head is selected

When CM head is selected, here
will become red.

2-6. Jog remote-controller (Option for some models)

This is a device to move the frame manually. Regarding how to use, refer to the detail page.(→p.64)

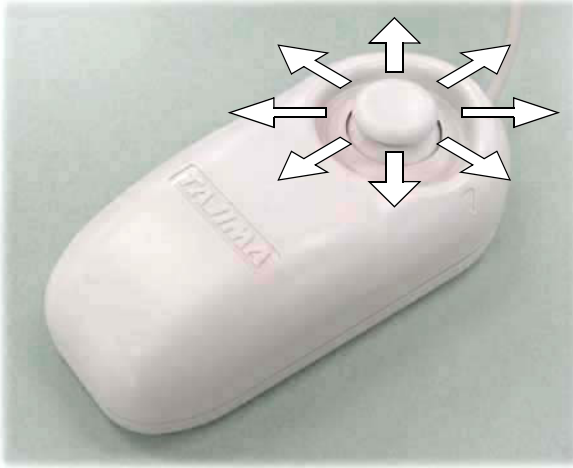

When not using, put it in the pocket.



Pocket

- 1
- 2
- 3
- 4
- 5
- 6
- 7
- 8
- 9
- 10
- 11
- 12

3. Chenille stitches

3-1. Sewing method

There are two types of stitches (loop stitches and chain stitches).

Loop stitches



Chain stitches



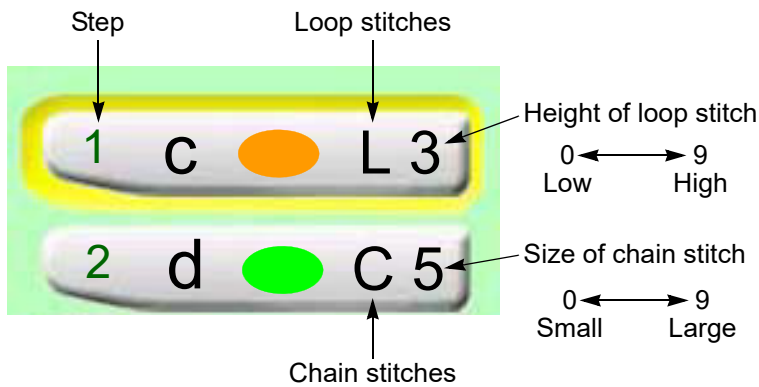

It is possible to switch the height of loop stitch and the size of chain stitch automatically in every step. The following is an example for setting Step 1 to loop stitches and Step 2 to chain stitches.



3-2. Needle for chenille stitch

Typical needles are shown in the chart below.

When a product includes many loop stitches, use PH-C70. When a product includes chain stitches only or you use thin fabric that tends to be caught by the hook part of needle, use PH-C120.

	PH-C70 (#11, #14, #16)	PH-C120 (#16)
		
Use	Dual use for loop/chain stitch	Exclusive for chain stitch
Suitable fabric	Thick fabric such as felt	Thin fabric or fine mesh knit fabric
Thread tension	Loop stitch: about 25 g / Chain stitch: about 35 g	Make it a little stronger than the left value.
Inner diameter of nipple	About +0.4 mm against needle diameter	About +0.2 to 0.4 mm against needle diameter
Position of nipple	Perform adjustment so that the nipple touches the needle plate in the following condition.	
	Needle height "0" Main shaft angle: 215 to 250°	Needle height "0" Main shaft angle: 215°

3-3. Looper

It is possible to perform six colors chenille stitches embroidery by six loopers. These loopers are called Looper a, Looper b, Looper c, Looper d, Looper e and Looper f (from right to left) .

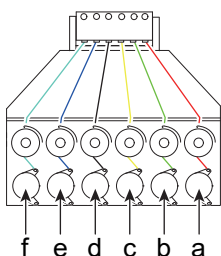
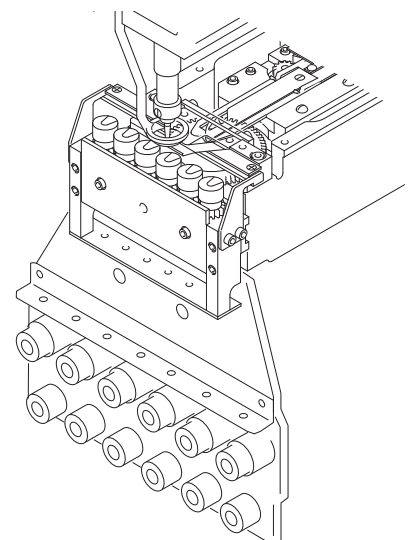
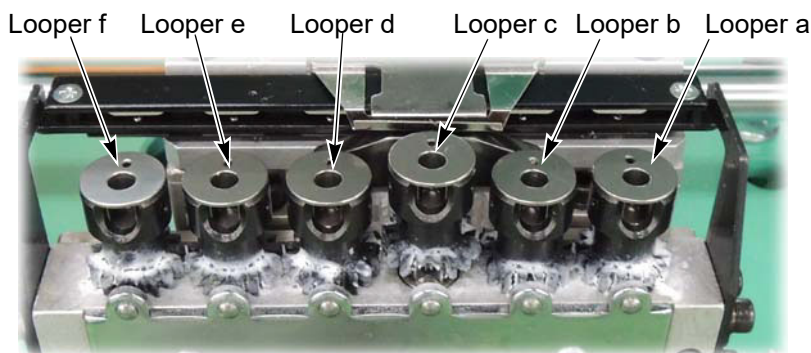

Loopers a to f are explained as the left illustration in this manual.

3-4. Combination of needle, nipple and needle plate

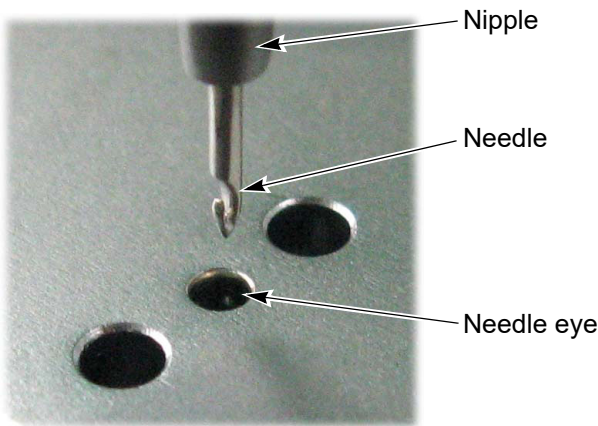

CAUTION

! In chenille stitches embroidery, improper combination of needle, nipple, needle plate and thread will cause trouble in finishing of sewing. When you change needle, change the combination by referring to the chart below as a rough standard.

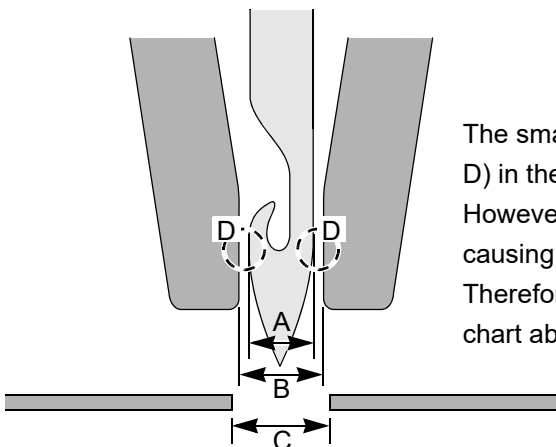

Use proper nipple, needle plate and thread according to the needle count number.

Needle count number (#)	Needle diameter (mm) (A in the figure below)	Inner diameter of nipple (mm) (B in the figure below)	Hole diameter of needle plate (mm) (C in the figure below)	Rayon thread count number (d)
11	0.75	1.0 to 1.2	1.4	120
14	0.9	1.1 to 1.3	1.4 or 1.6	120/300
16	1	1.2 to 1.4	1.6 or 1.8	300



The smaller the difference between A and B (the smaller the gap D) in the left figure is, the better the finishing of embroidery is. However, if the gap D is too narrow, dust will pile up in the nipple, causing breakage of needle and/or damage of parts in the head. Therefore, do not use thinner nipples than those described in the chart above for combination.

3-5. Optional device of CM head

For details, refer to the separate manual for option.

3-5-1. MT-1

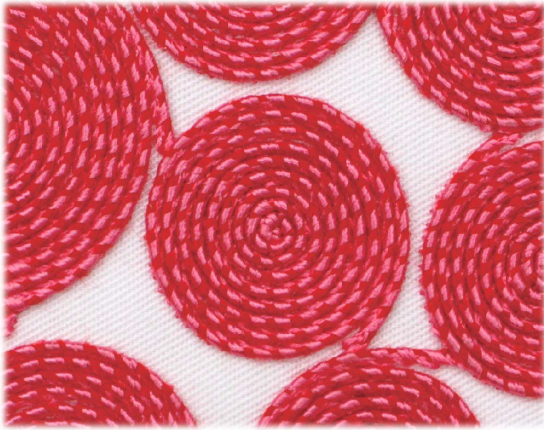

It is possible to perform coiling and taping. (The left illustration is an example of coiling.) When this device is equipped to the machine, set "M-axis" to "YES".

(SET*F4:5 Machine information)



3-5-2. KT-1

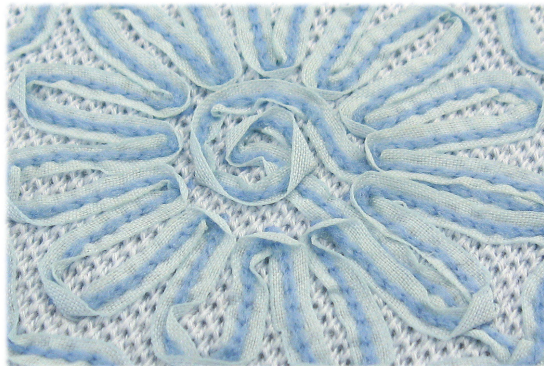

It sews on tape material by chain stitches. When this device is equipped to the machine, set "KT-1" to "YES". (→p.214)

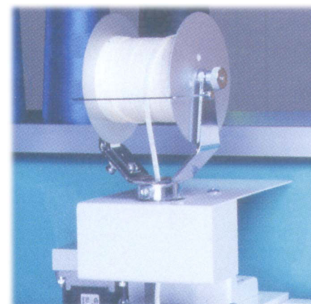

3-5-3. K-2



It sews on cord material by chain stitches.
No setting on the operation panel.

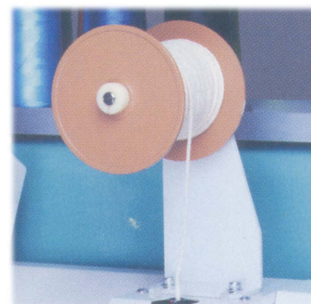

1
2
3
4
5
6
7
8
9
10
11
12

Chapter 3

Screen

1. Screen display	28
2. Message display	33

1

2

3

4

5

6

7

8

9

10

11

12

1. Screen display

1-1. Main screen

When the power is turned ON, the following screen will appear. From this screen, setting/operation to embroider will start. To return to the main screen from other screen, press E key until the main screen appears.

1-1-1. Screen

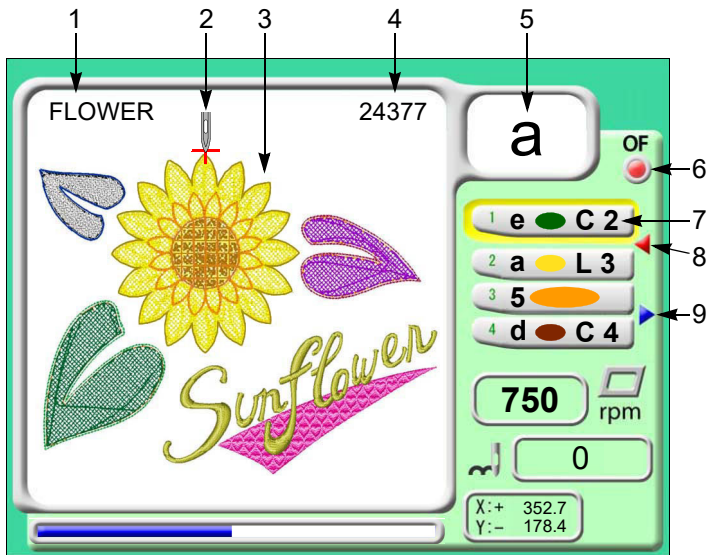

1. Design name
2. Start point of design
3. Design (data set design) to be embroidered from now
4. Total stitch number of design
5. In case of TCMX-600 series, the currently selected looper (a to f) will be displayed.

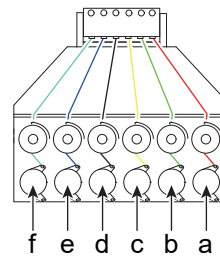

In case of TCMX-mixed type series, the currently selected needle bar No. or looper (a to f) will be displayed.

6. Setting of Automatic Offset(→p.176)

: With, : Without

7. Step(→p.53)
8. Setting to return the frame to the front during embroidery (→p.178)

: With setting

9. Forced start(→p.54)

: With setting

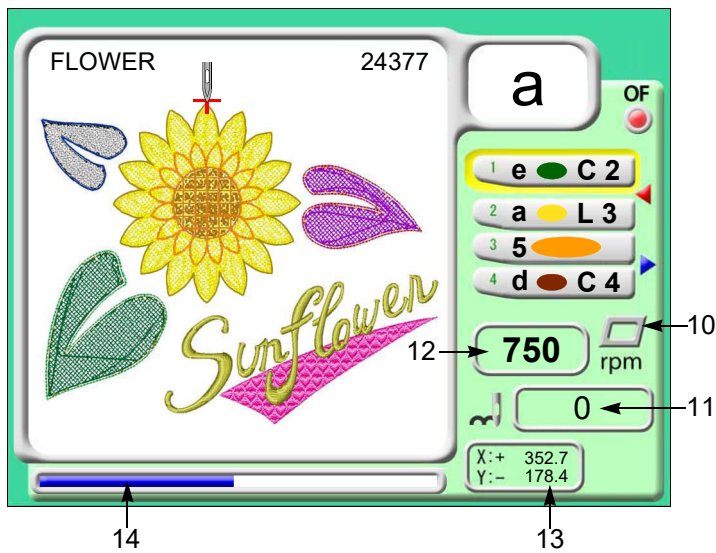

10. Current set frame

: Border frame

: Border frame 2

11. Current number of stitches

12. Maximum speed of the currently selected head
(→p.67)

13. Current frame position

14. Completed ratio of embroidery

1
2
3
4
5
6
7
8
9
10
11
12

1-2. List screen

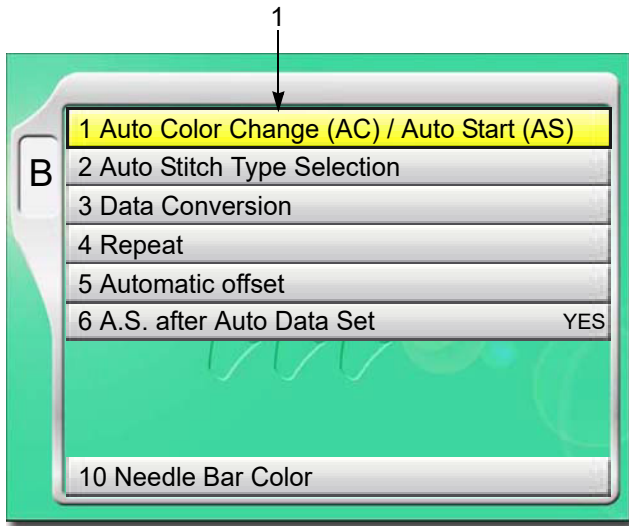

The screen shown left will be displayed if B key is pressed.

1. Cursor
Selected item will be displayed in yellow.
- To lower the cursor, press B key or ▼.
- Pressing [SET] will switch to "Setting screen".

1-3. Setting screen

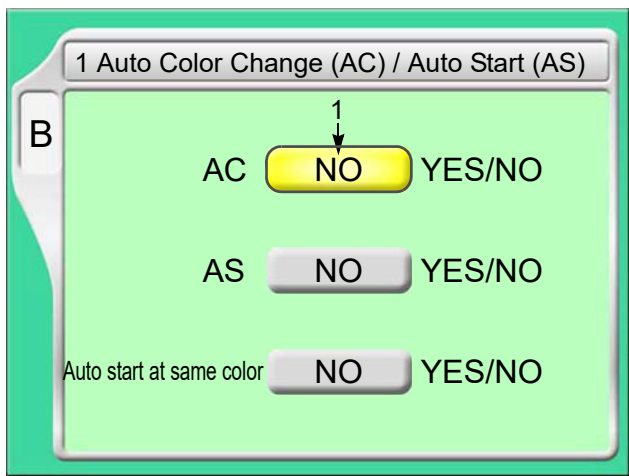

1. Select YES/NO by using the jog dial and press SET key.

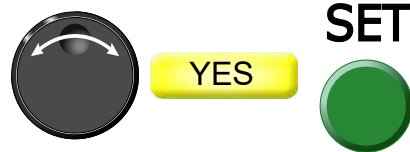

- To lower the cursor, press SET key or ▼.
- To return the screen, press E key.

1-4. Character/numeric value input screen

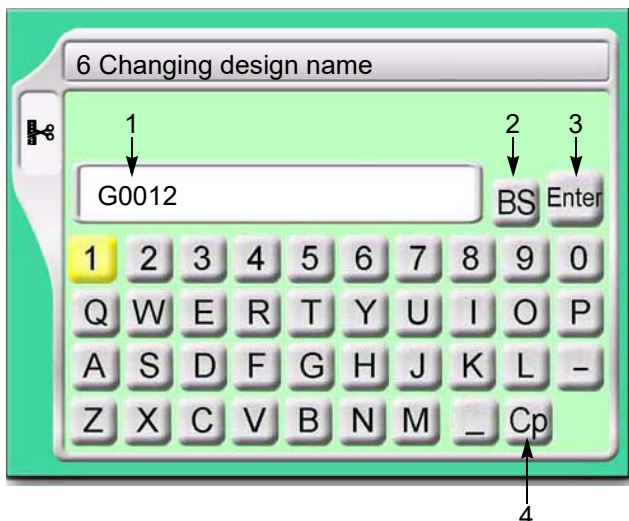

1. File name (up to 8 characters)
2. To return the cursor or delete the character.
3. To determine the input character and numeric value.
4. Switching of large letter/small letter

[How to input]

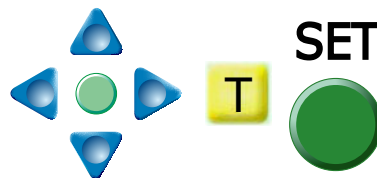

After finishing input, press Enter and SET key.

1-5. Design confirmation screen

It is possible to check the setting content of the design to embroider from now and the occurrence record of stop factors (Error Stack).

To switch to the design confirmation screen, press i key.

Pressing again i key will switch to the next screen.

To return to the original screen, press E key.

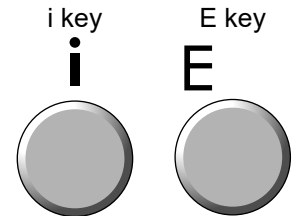

1: Design (data set design) to be embroidered from now
 2: File name
 3: Design size
 4: Total stitch number of design
 5: Current frame position
 6: Current number of stitches
 7: Current stitch contents
 8: Number of times of embroidering this design continuously
 9: Step

1. Design (data set design) to be embroidered from now
2. File name
3. Design size
 + : Design Start Point (starting position of design)
4. Total stitch number of design
5. Current frame position
 Distance from design start point
6. Current number of stitches
7. Current stitch contents
8. Number of times of embroidering this design continuously
9. Step

Number of steps Automatic Offset
 Step 1/ 10 Offset
 3. 10. 5. 7. 2. 7. 8. 4. 1. 9.

Current step (red) Auto Color Change Off

12: Current setting contents

13: It indicates the next page exists.
 14: Stop factor occurred at last(→p.228)

10. Scaling up/down/reversion of design
11. Design repetition
12. Current setting contents
13. It indicates the next page exists.
 ▼ Pressing key will scroll the page.
14. Stop factor occurred at last(→p.228)

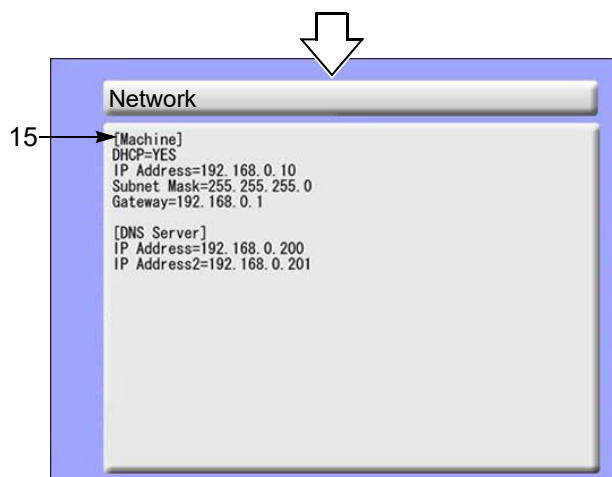

15. Network information

The screen shown left will be displayed even if Network is set to "NO". Contents of display differ depending on individual environment.

2. Message display

2-1. Condition data

When registering the design (saving format is T3, or T2 design) saved in the USB memory into the machine memory, the following message will appear.

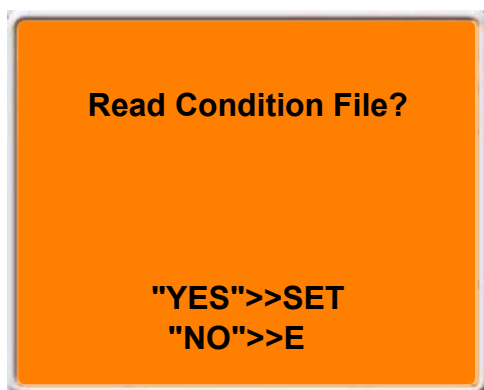

Condition data means the following two items in this case.

(1) Color change sequence

The whole color change sequence included in the design can be registered into the machine memory. Therefore, it is unnecessary to set it again.

(2) Start point of design

The frame position where the machine started embroidering last time can be registered in the machine memory. Therefore, it is unnecessary to adjust the position of the frame.

There are following three items of condition data except the one described above. By setting them after data set, each setting contents will be added in a design. Therefore, it is unnecessary to perform setting again when you embroider this design next time.

- (1) Scaling up/down/reversion of design**(→p.120)
- (2) Design repetition**(→p.122)
- (3) Automatic Offset**(→p.176)

2-1-1. When reading the design (Example: TAJIMA_W) saved in the USB memory by a personal computer

Indications in a personal computer are different as shown in the chart below depending on the saving format (T3, T2, T) of the design.

Saving format	Indication in personal computer	Use
T3	TAJIMA_W.TCF	Data integrating CT0, DGF and TBF of T2
T2	TAJIMA_W.CT0	Color change sequence, design start point
	TAJIMA_W.DGF	Size-reduced design (Thumbnail)
	TAJIMA_W.TBF	Stitch data of TAJIMA binary format
T	TAJIMA_W.DST	Stitch data of TAJIMA ternary format

[About T2]

One design will be generated by three types of indication file (TAJIMA_W.CT0, TAJIMA_W.DGF, TAJIMA_W.TBF). Therefore, please handle these three files for one design.

2-1-2. Saving or reading of condition data

Condition data can be saved or cannot be saved depending on its place to save.

O: Can be saved / X : Unable to save

Condition data	Saving into machine memory	Saving into USB memory		Saving from DG/ML by Pulse into the machine memory
		T3, T2	T	
1. Color change sequence	O	O	X	O
2. Start point of design	O	O ^[*1]	X	O
3. Data Conversion ^[*2]	O	X	X	X
4. Repeat of design	O	X	X	X
5. Automatic Offset	O	X	X	X

[*1]When embroidering the design between models with different embroidery spaces, the start position of the design may differ depending on the model.

[*2]Scaling up/down/rotation/reversion of design

2-2. Start point of design

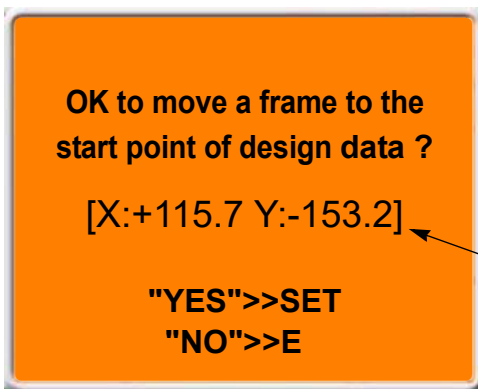

The message shown left will be displayed only when the machine reads condition data at "2-1."

This message is displayed when performing data set. Design start position means the frame position where the embroidery of this design was started last time.

These figures mean the destination of moving the frame. Frame coordinates are shown.

2-3. Offset Return

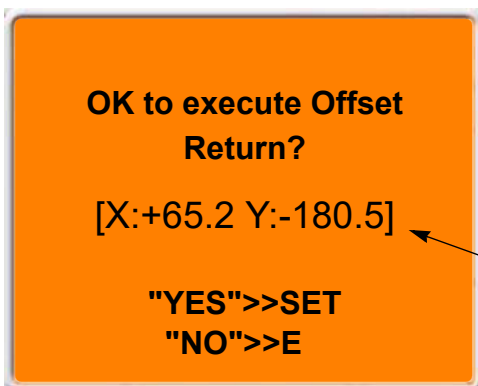

The message shown left will be displayed only when the machine has the setting of "Automatic offset".

This message is displayed when performing data set. Offset return means the offset start position where this design was embroidered last time.

These figures mean the destination of moving the frame. Frame coordinates are shown.

Chapter 4

How to perform embroidery

1. To turn ON the power.....	36
2. Setting of the fabric, passing of the thread	38
3. Registration of a design into the machine memory.....	43
4. Decision of an embroidery design and the color change sequence .	50
5. Decision of the design start position	60
6. Check items before embroidering	67
7. Embroidery starts.....	72

1

2

3

4

5

6

7

8

9

10

11

12

1. To turn ON the power

 CAUTION	
⊘ Do not turn ON the machine power in the state that the USB memory is connected to the operation panel except when installing the software in the machine. The system sometimes may not start up.	

1-1. Power switch

There are following types of the power switch depending on the model.

1-1-1. TCMX-601

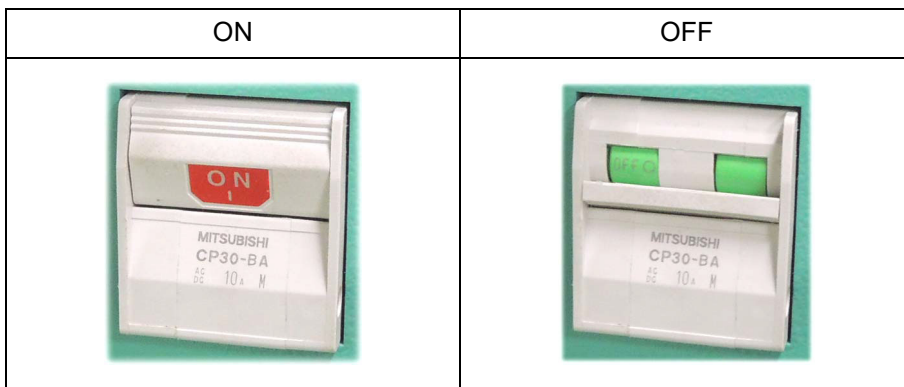

1-1-2. TCMX-mixed type (L)

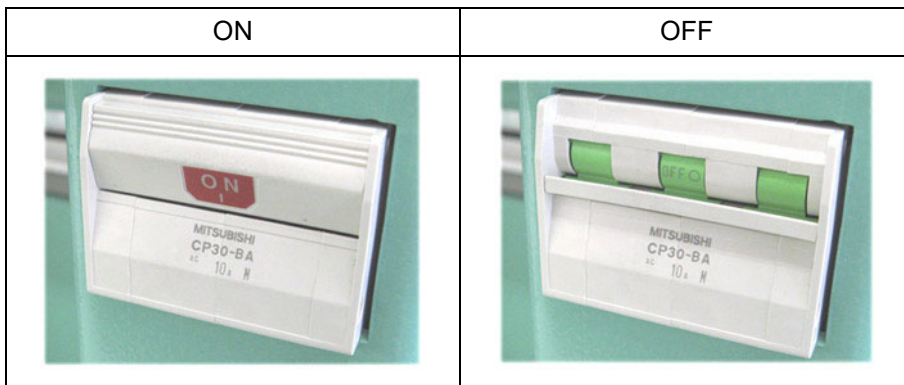

1-1-3. TCMX-600, TCMX-mixed type, TCMX-mixed type (L)

This type can be locked.

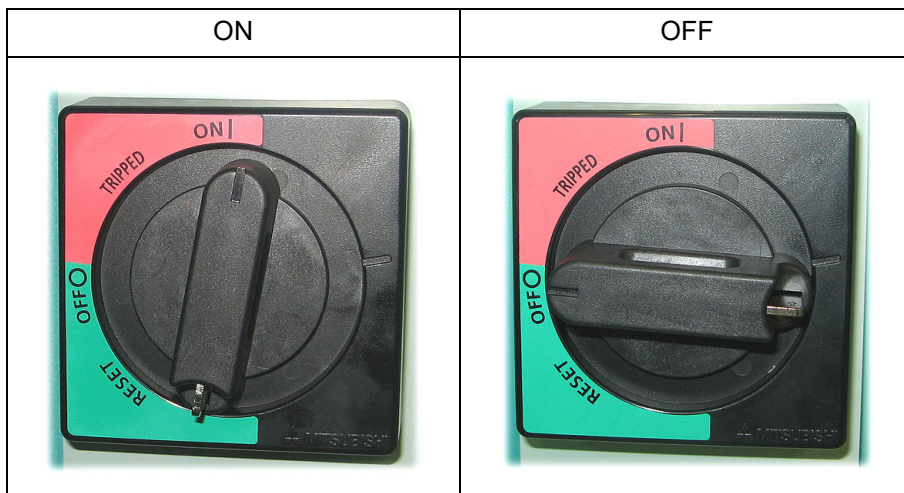

[When locking]

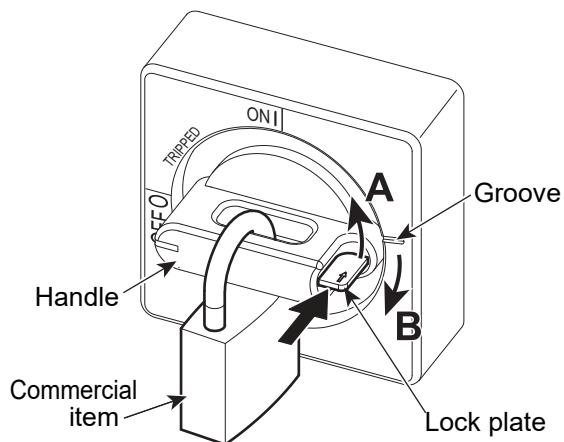

- (1) Turn the handle toward direction A to the position of the groove.
- (2) Push the lock plate to the direction indicated by a big arrow and return the handle to the direction B (the original position).
- (3) Lock.

1-2. To turn ON the power

- (1) After turning on the power, the screen will switch as the figure below. Wait for a while until the power starts up.

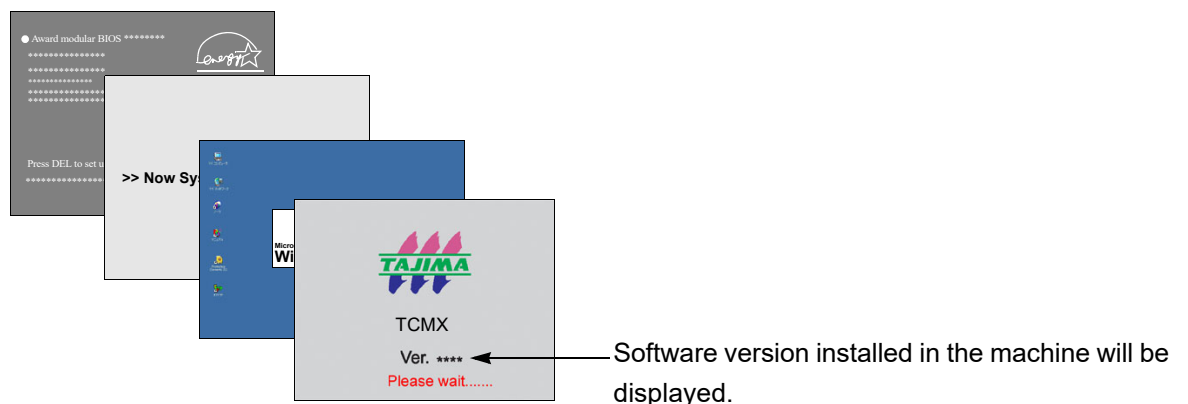

2. Setting of the fabric, passing of the thread

2-1. To set fabric

In case of chenille embroidery, stretch the fabric firmly.

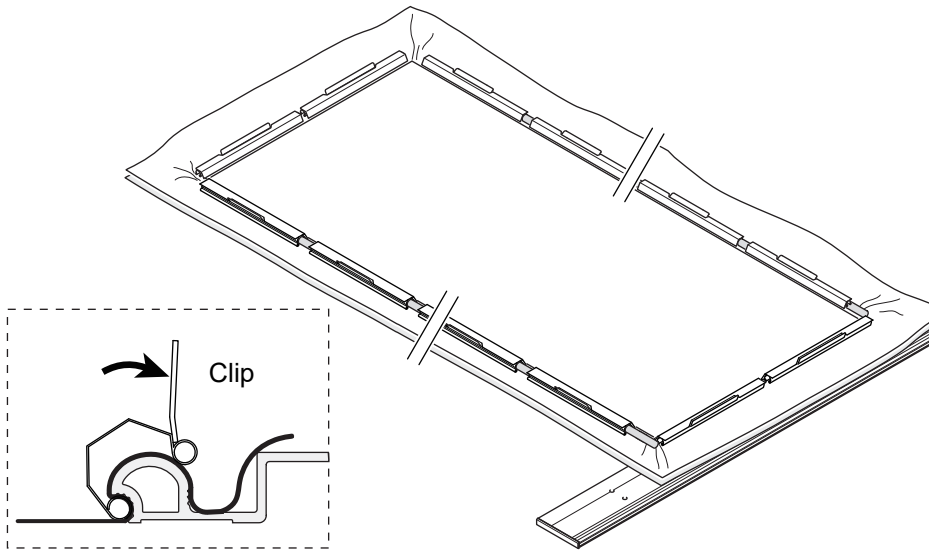

2-2. Thread passing

2-2-1. CM head

(1) Pass the thread through the first tension.

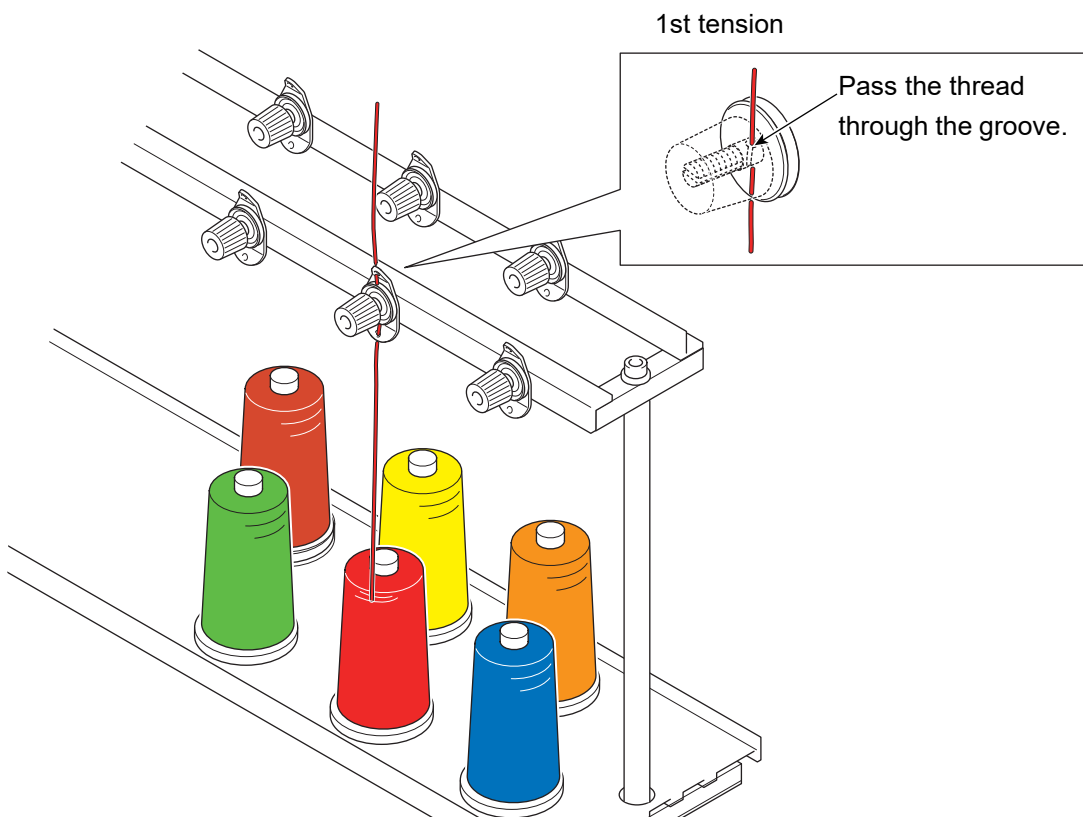

(2) Pass the thread through the 2nd tension and the 3rd tension.

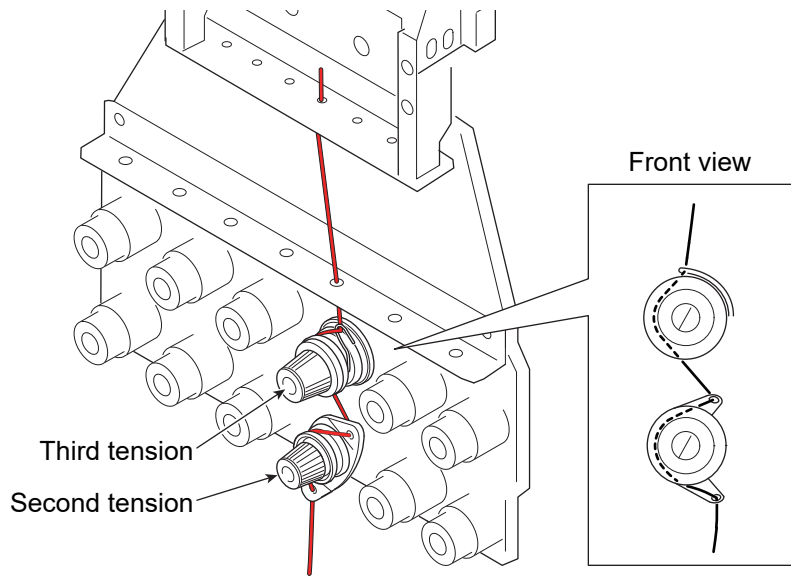

(3) Stick the threader (accessory) to the fabric and put it into the rear hole of the needle plate. Pass the thread through the tip of the threader, then pull it up. The threader can be passed from the bottom to the top. After threading, trim the thread by manual thread trimming. the start point of sewing will be stable.

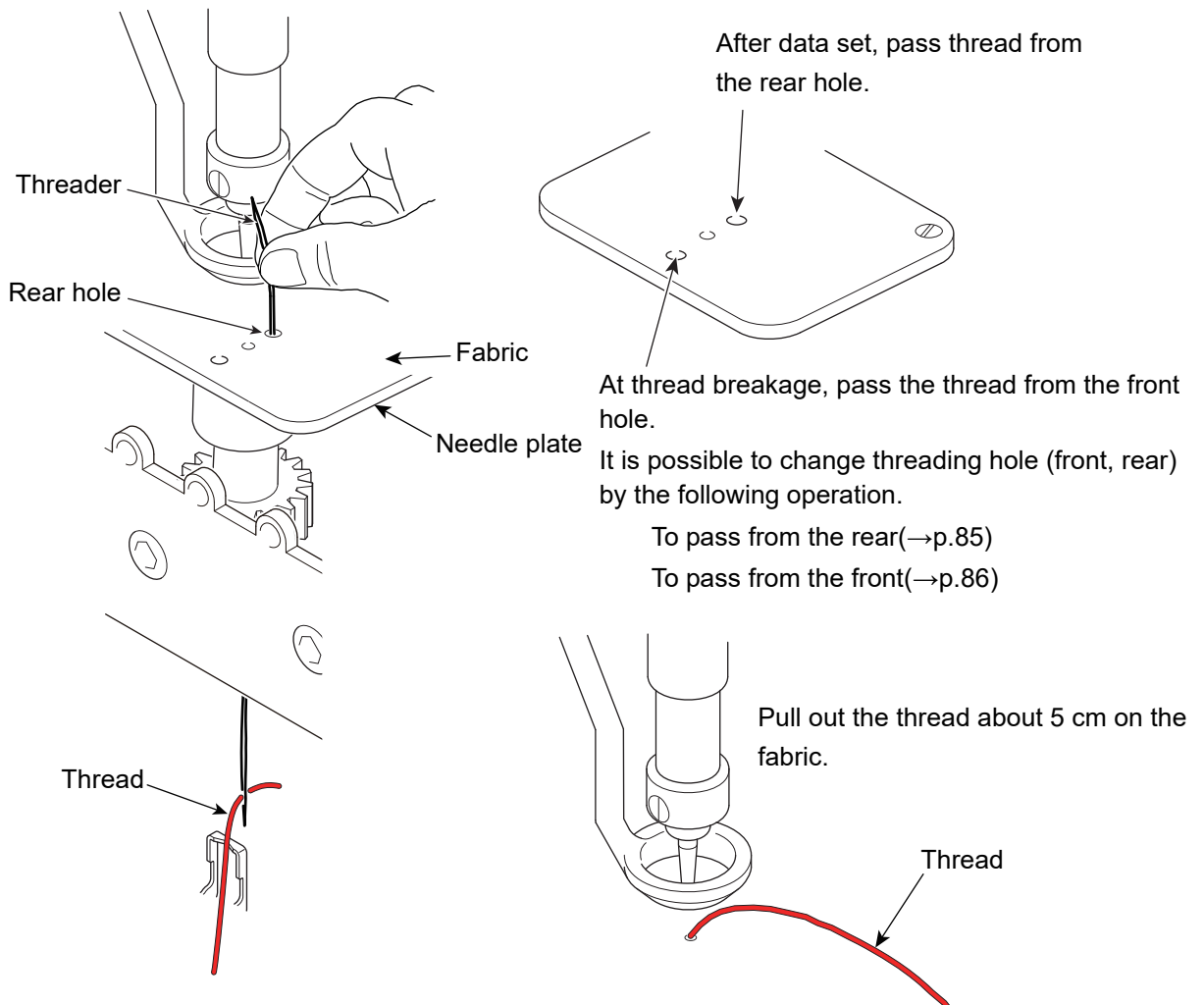

2-2-2. FM head (TCMX-mixed type series)

If the thread does not pass to each section correctly, it could cause trouble such as the deterioration of embroidery or the thread breakage, etc. Pass the thread correctly referring to the figure below.

- (1) Place the thread cone on the thread stand blade.
- (2) Pass the thread through the thread course.

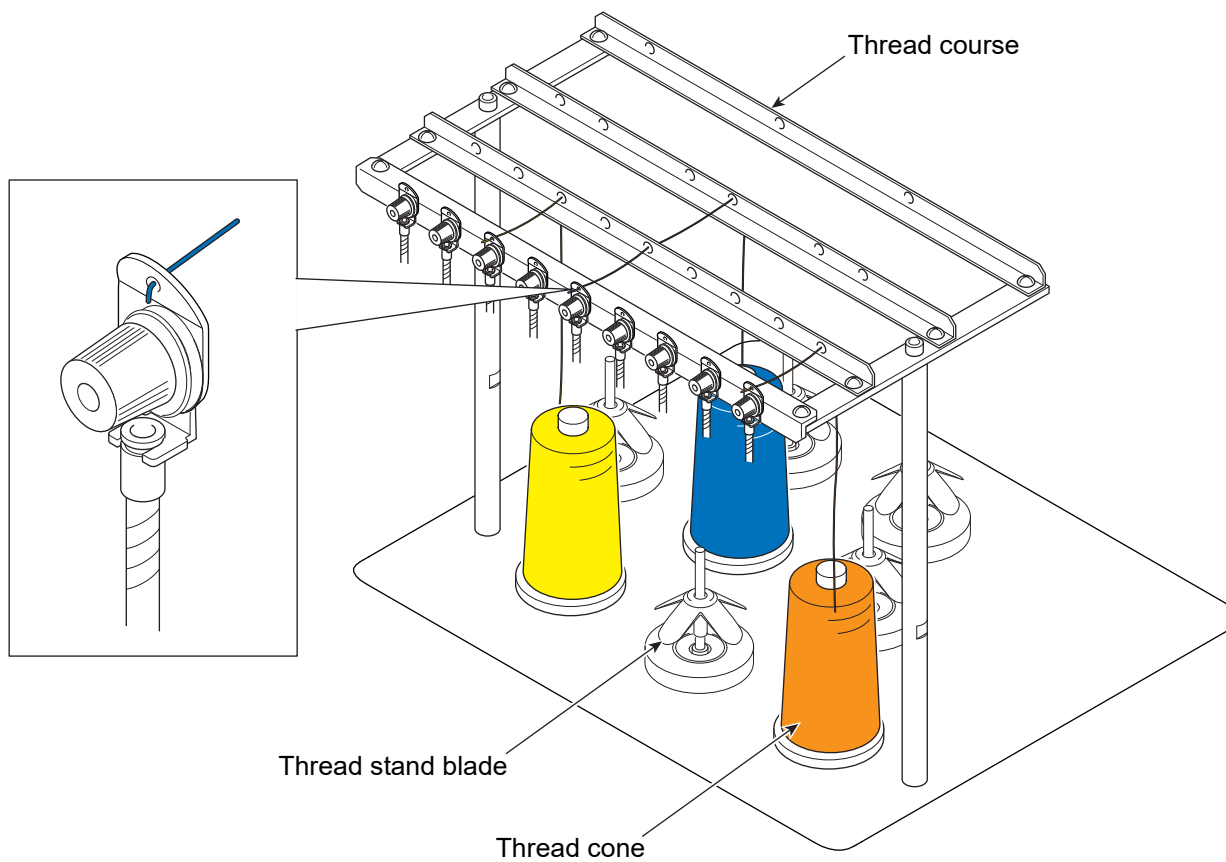

- (3) Put the thread into the groove of the tension stud. (Indicated by an arrow)
- (4) To perform threading through the spiral tube, use the threader (accessory).

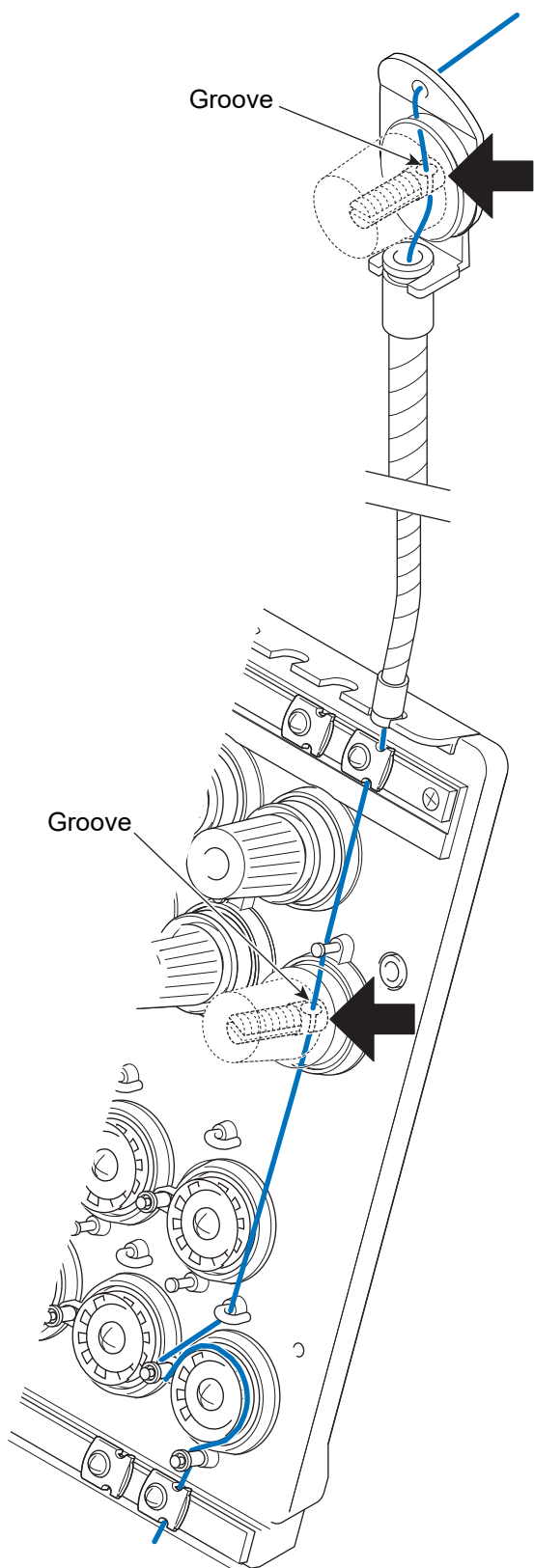

Threading through spiral tube

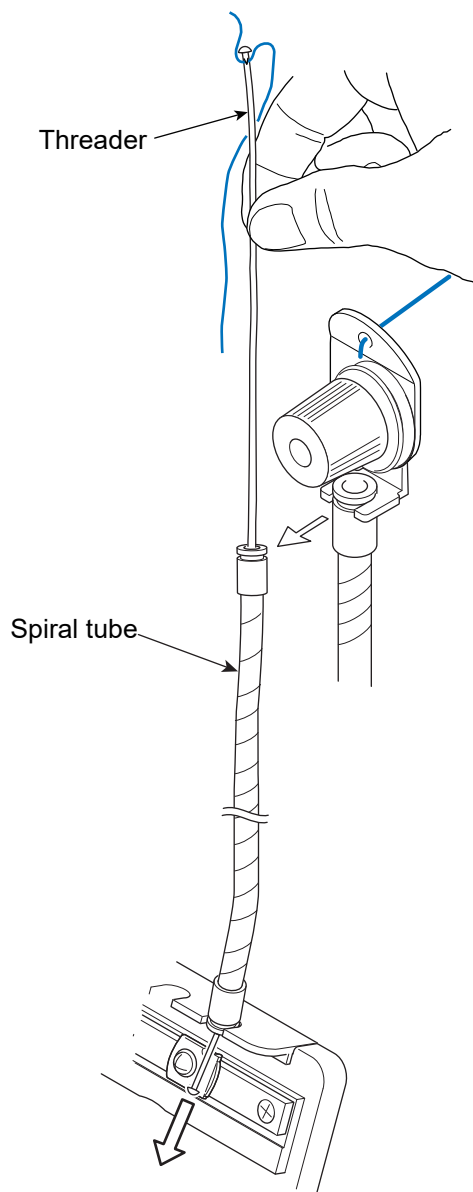

1
2
3
4
5
6
7
8
9
10
11
12

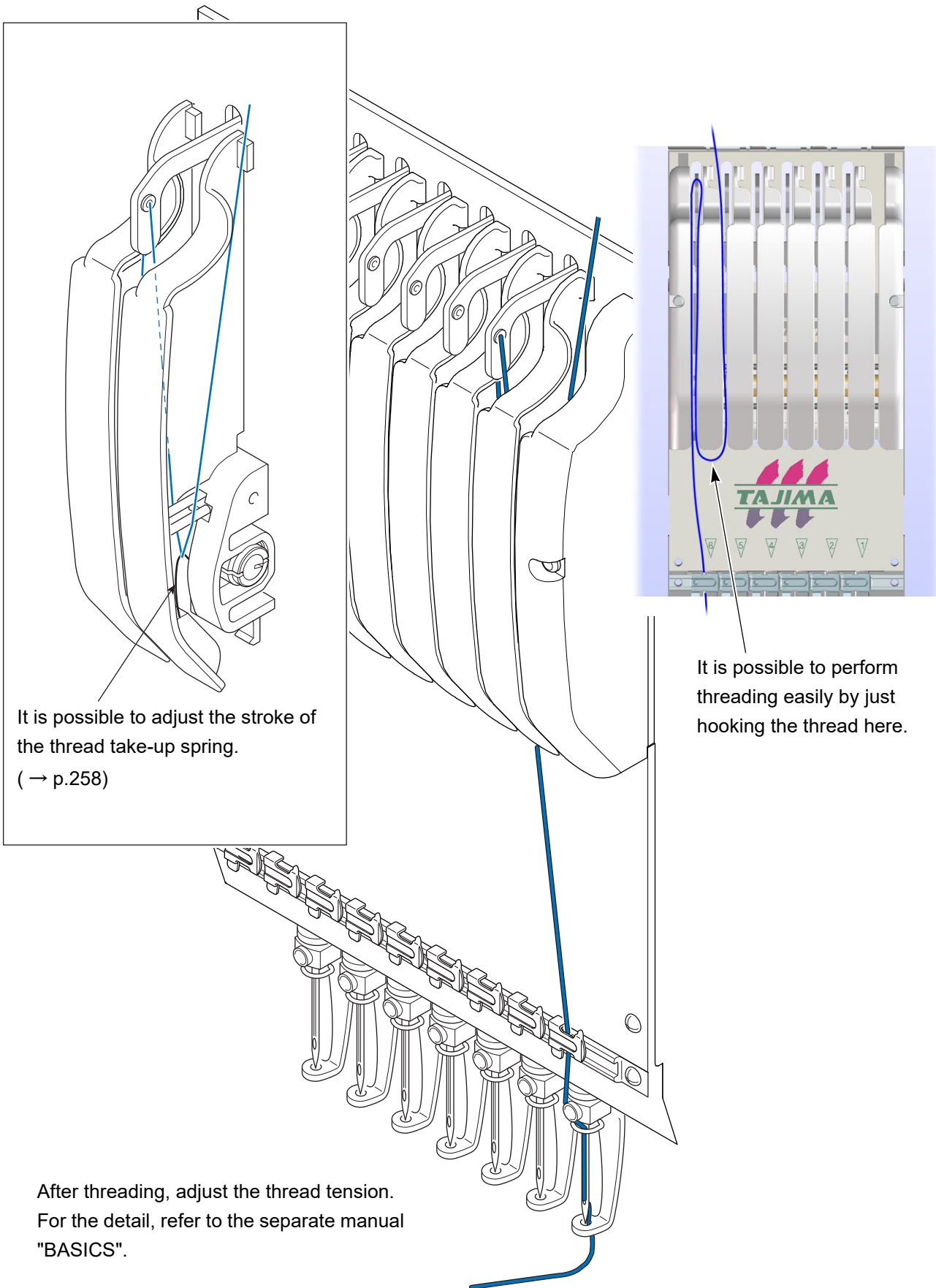

It is possible to adjust the stroke of the thread take-up spring.
(→ p.258)

It is possible to perform threading easily by just hooking the thread here.

After threading, adjust the thread tension.
For the detail, refer to the separate manual "BASICS".

3. Registration of a design into the machine memory

Register designs in the machine memory by the following methods.

- (1) Use USB memory
- (2) Use personal computer (DG/ML by Pulse is necessary)

3-1. To use USB memory (Data Input USB)

Register designs saved in the USB memory into the machine memory. The maximum number of stitches per design is 1,000,000 stitches.

3-1-1. Screen

[17-inch operation panel]

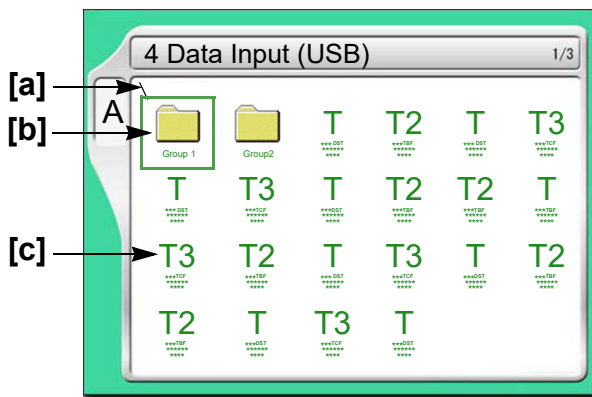

Folders and designs saved in the USB memory will be displayed. The design except the one shown at left will be displayed depending on a saving format of the design.

[6.5-inch operation panel]

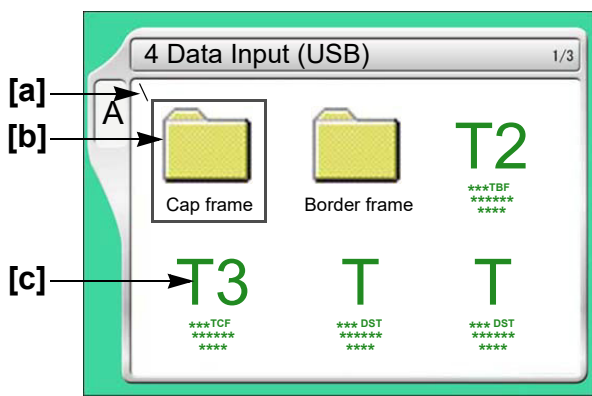

[a] Folder layer

The folder in the USB memory can be read up to three levels. The total of folders and designs that can be read per 1 level is 255 designs.

- \ : Root folder
- \\ : Folder (First level)
- \\\ : Folder (Second level)
- \\\: Folder (3rd level)

[b] Folder

[c] Design

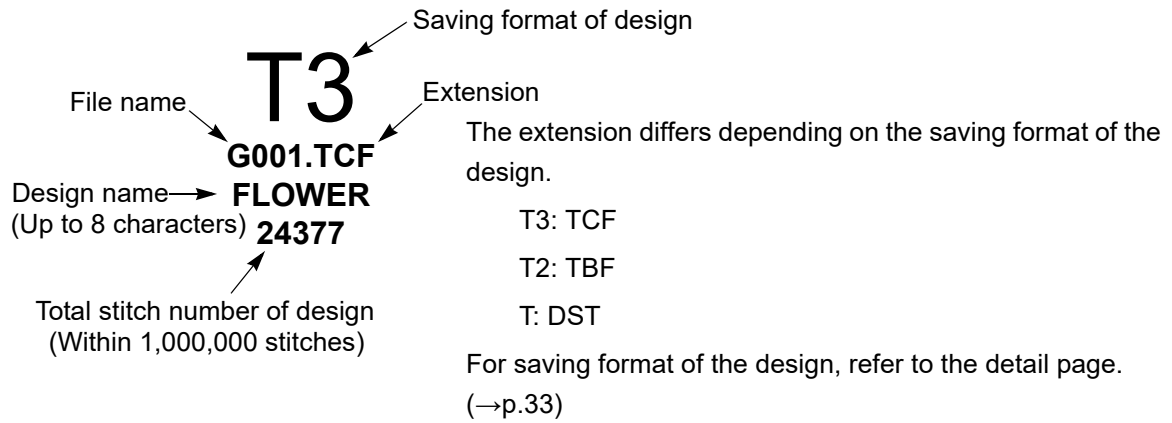

3-1-2. How to operate

The following is an example of registering a design saved in the USB memory into the machine memory.

(1) To set USB memory

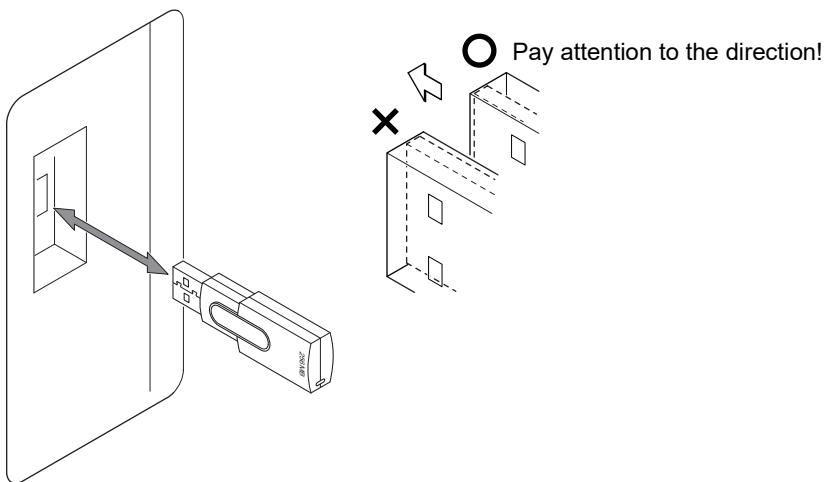

(2) To open screen

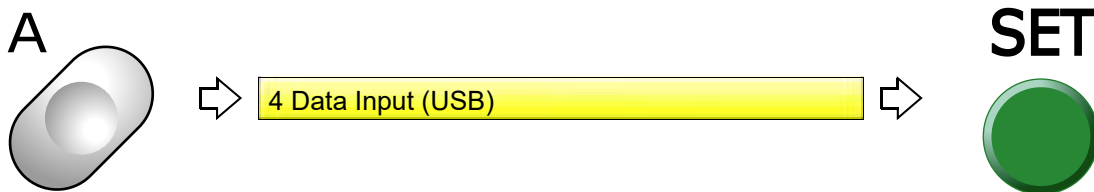

(3) To select a design

The operation differs depending on the storing place of the design.

(a) Design in folder

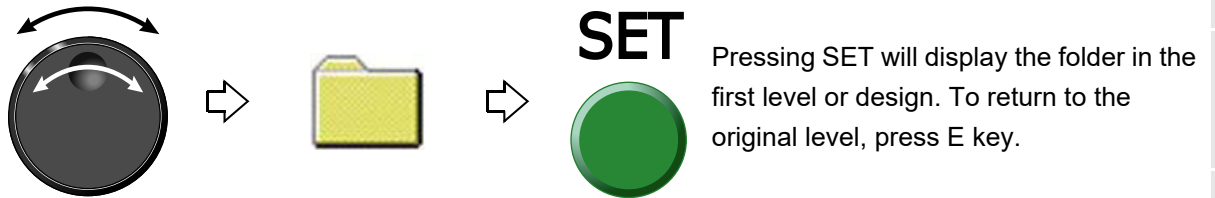

(b) Design on screen

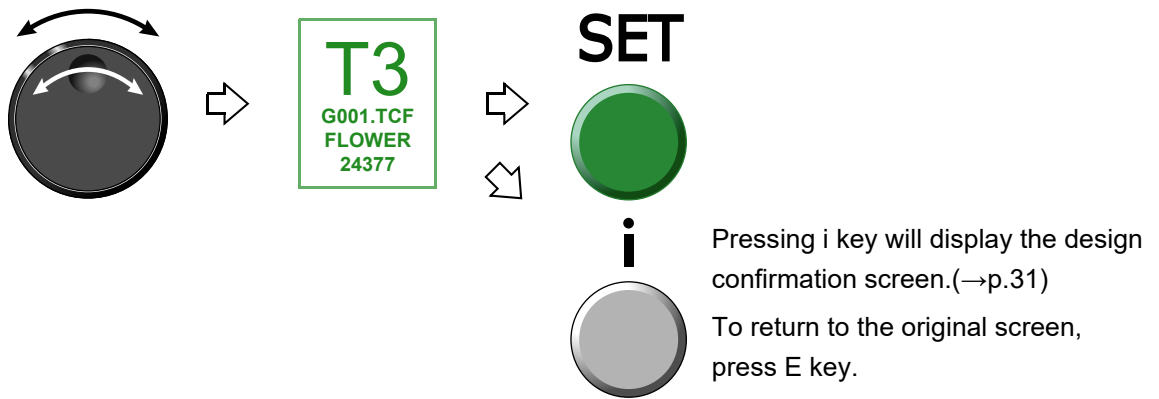

(c) Check the design.

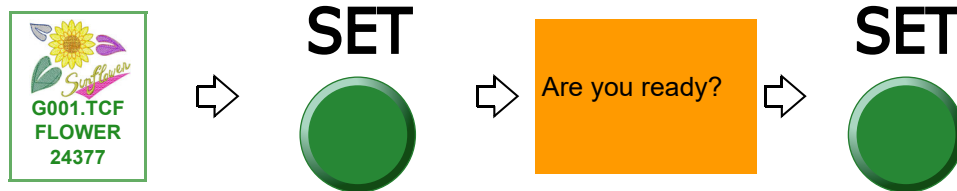

(4) To read condition file

If the saving format of the selected design is T3 or T2, the following message will appear.

Condition file means Color Change Sequence and Design Start Position.

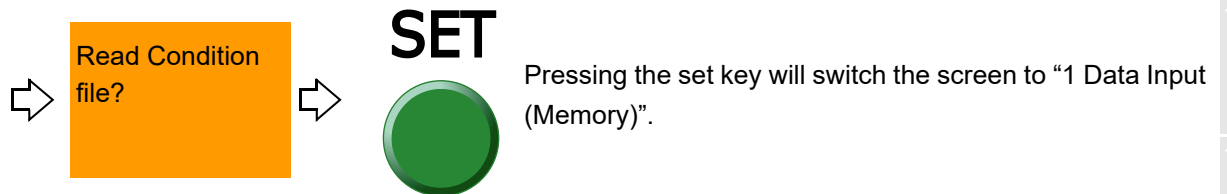

After that, proceed to "To decide embroidery design (Data Setting)"(→p.50)".

1
2
3
4
5
6
7
8
9
10
11
12

3-2. To use personal computer (Data Input LAN)

Register designs (saved in the personal computer) into the machine memory. Besides, it is possible to more easily register the designs into the machine memory using a commercially available bar code reader (*). The maximum number of stitches per design is 800,000 stitches.

(*) It is possible to use only the USB connection bar code reader supporting CODE39.

Software sold separately (DG/ML by Pulse) and setting of IP address are necessary to perform this operation. For details, consult the distributor.

[Example of connection]

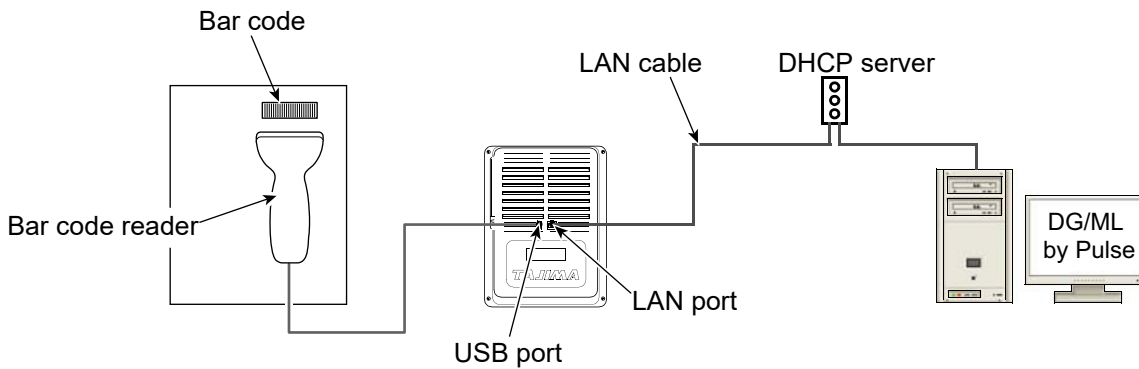

3-2-1. Screen

For 17-inch operation panel

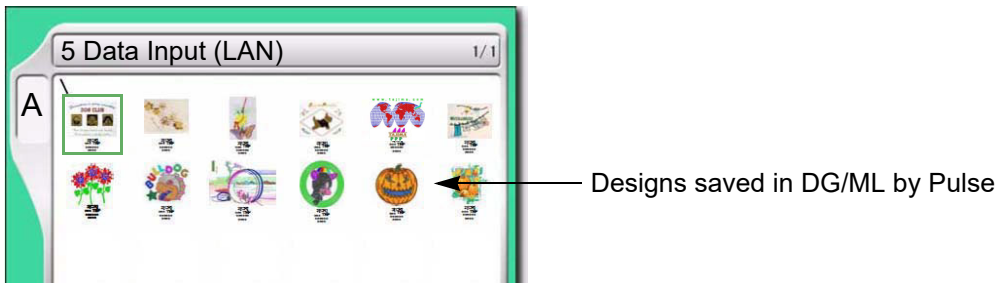

3-2-2. How to operate (not to use bar code reader)

The following is an example of registering a design (saved in a personal computer) into the machine memory.

- (1) After connecting the LAN cable to the LAN port at the back of the operation panel, start up DG/ML by Pulse.
- (2) Check if network setting is "YES".(→p.206)
- (3) To open screen

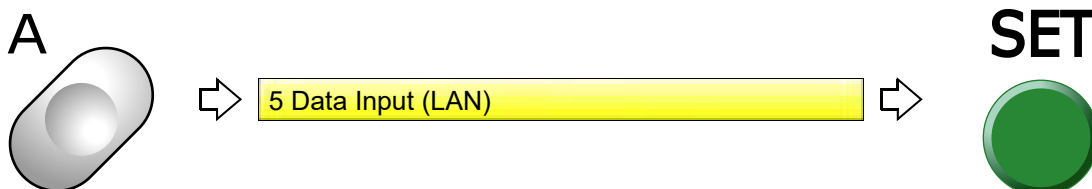

(4) To select a design

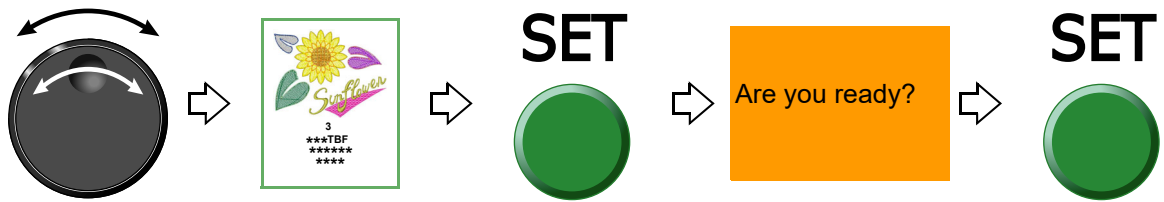

(5) To read condition file

If the saving format of the selected design is T3 or T2, the following message will appear.
Condition data means the Color change sequence.

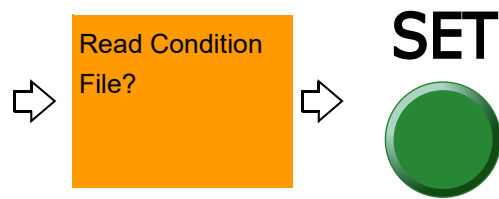

This design is now ready for embroidery. (Data set is completed).

After that, proceed to "To decide order of embroidery type (Auto Stitch Type Selection)"(→p.53)

1
2
3
4
5
6
7
8
9
10
11
12

3-2-3. How to operate (to use bar code reader)

The following is an example of registering a design (saved in a personal computer) into the machine memory.

- (1) After connecting the LAN cable to the LAN port at the back of the operation panel, start up DG/ML by Pulse.
- (2) Check if network setting is "YES".(→p.206)
- (3) Connect the bar code reader to the USB port of the operation panel.(→p.17)

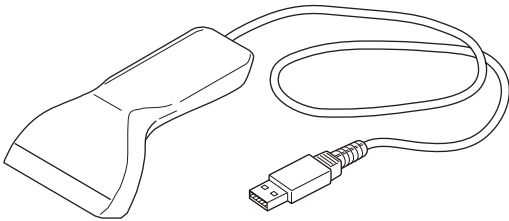

- (4) Set to the main screen.



The bar code can be read also from the following screen.

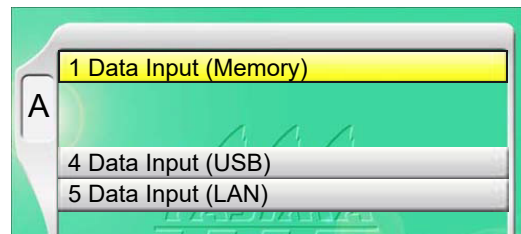

- (5) Read the bar code.

Condition data (Color change sequence) is also read automatically.

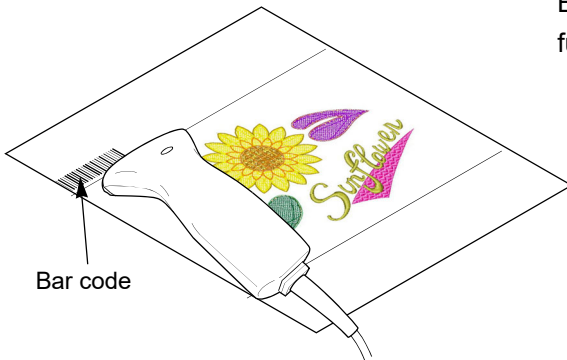

Bar codes can be printed by using the print function of DG/ML by Pulse.

This design is now ready for embroidery. (Data set is completed).

After that, proceed to "To decide order of embroidery type (Auto Stitch Type Selection)"(→p.53)

If the bar code cannot be read, error code No.BC1 will be displayed. The following points are given as factors.

- (a) Selected design is not stored in Spooler

Spooler: Area to store the design temporarily in a personal computer

- (b) Misreading by bar code reader

Deal with above troubles with the following procedure. If these troubles are not solved, please consult the distributor.

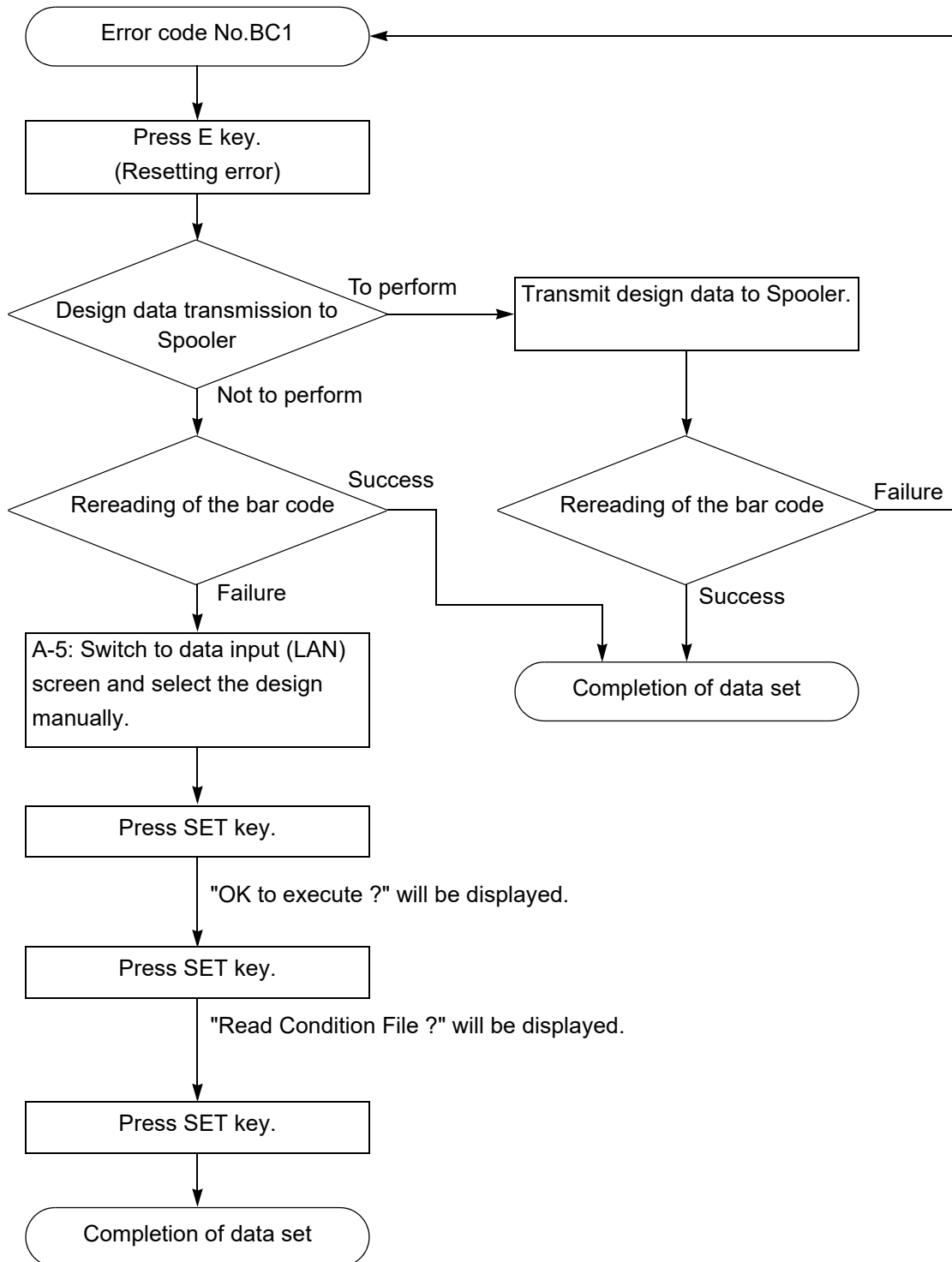

4. Decision of an embroidery design and the color change sequence

4-1. To decide embroidery design (Data Setting)

Select the design in the machine memory and enable to embroider.

The design can be registered to the machine memory up to 200 designs (2,000,000 stitches).

4-1-1. Explanation on the screen

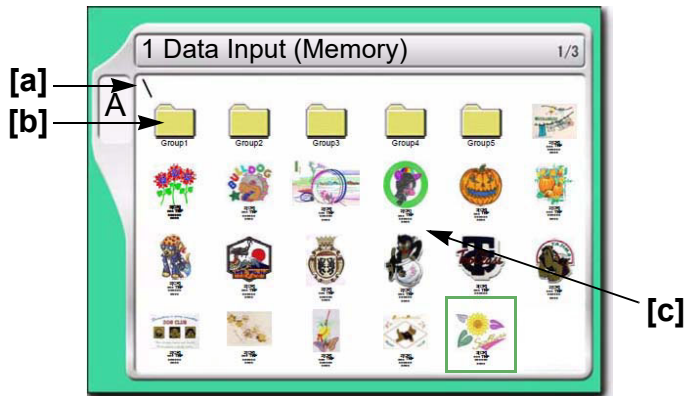

[a] Folder layer

The root folder and folder on the first level of the machine memory can be displayed.

\ : Root folder

\\ : Folder Group 1 to 5 (First level)

[b] Folder

[c] Design registered in the machine memory

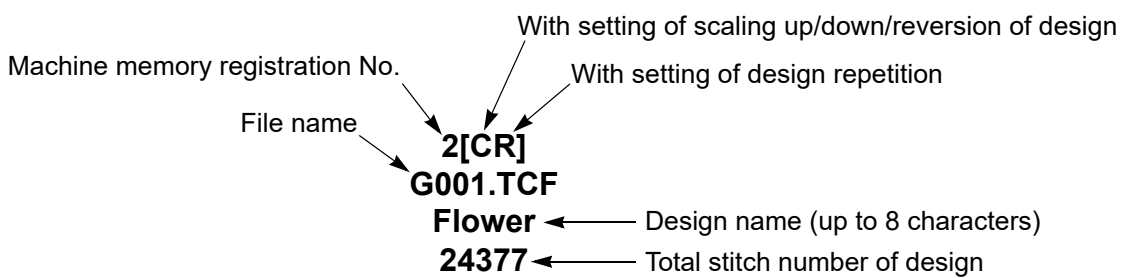

4-1-2. How to operate

This is an example of selecting the design in the memory of the machine and enabling to embroider.

(1) To open screen

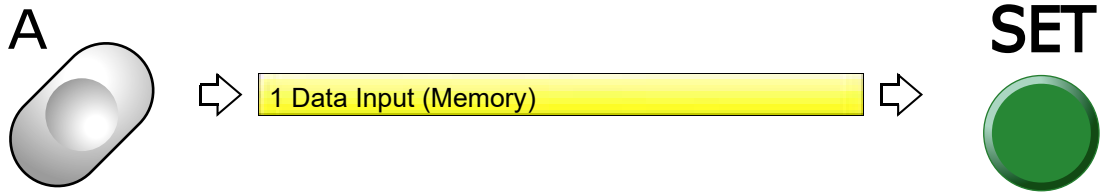

(2) To select a design

The operation differs depending on the storing place of the design.

(a) Design in folder

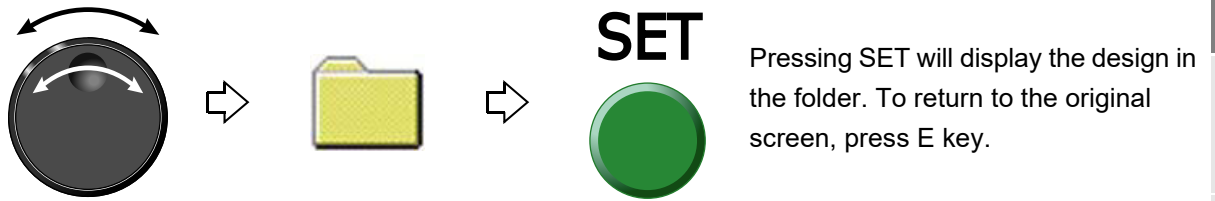

(b) Design on screen

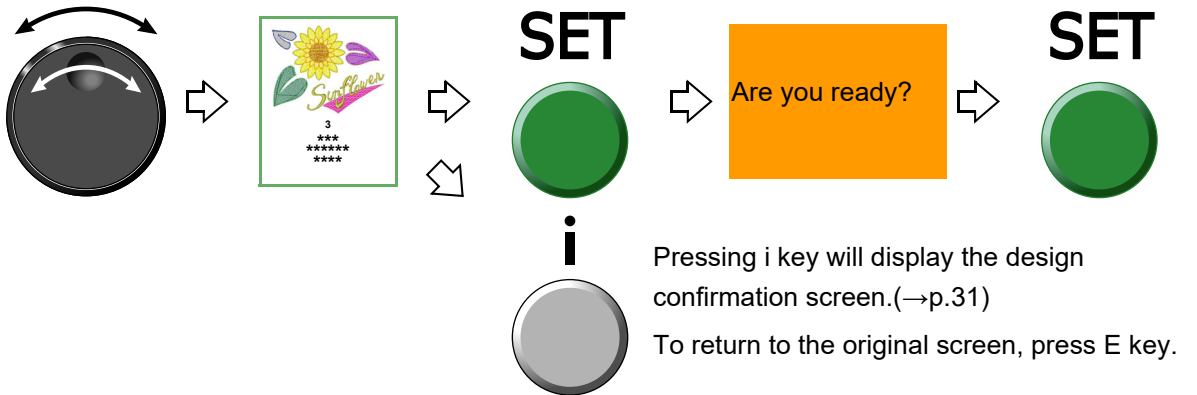

1
2
3
4
5
6
7
8
9
10
11
12

(3) To move frame to the design start position

 **CAUTION**

 When performing this operation, do not put your hands, etc. on the table. Moving the frame could injure you.

OK to move a frame to the start point of design data ?

SET
 Pressing SET will move the frame, then data set will be completed.

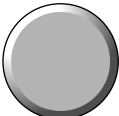
E
 When the movement of the frame is not desired Data set is completed.

4-2. To decide order of embroidery type (Auto Stitch Type Selection)

This setting is unnecessary when the color change sequence is already included as the condition data in the design to be embroidered from now.

4-2-1. Explanation on the screen

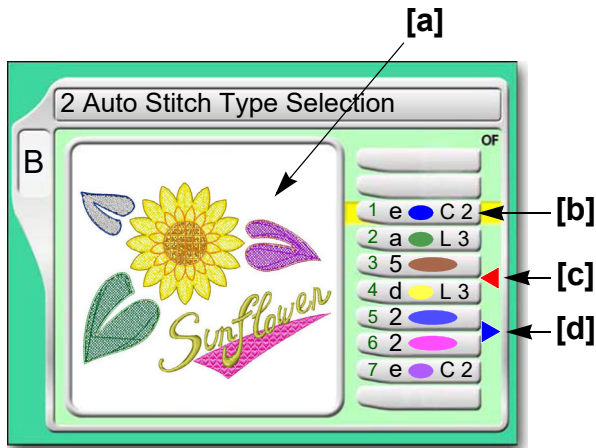

[a] Design (data set design) to be embroidered from now

[b] Step

The section divided by a color change code in the design data. The first section is called step 1, and the next section is called step 2.

[CM head]

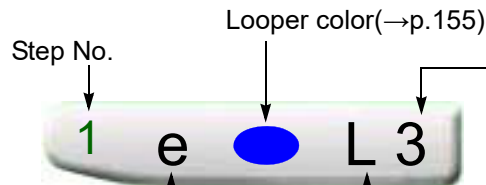

An example for selecting looper e

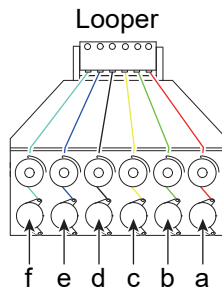

Sewing method

L: Loop

C: Chain

M: MT-1 (Coiling)^[*1]

T: MT-1 (Taping)^[*1]

Needle height

The setting ranges are below 10 steps.

0, 1, 2, 3, 4, 5, 6, 7, 8, 9

If a small value is selected, the loop stitch and the chain stitch will be small.

If a large value is selected, the loop stitch and the chain stitch will be large.

[*1] *1:M and "T" will be displayed only when MT-1 (option) is equipped.(→p.213)

TCMX-mixed type series

[FM head]

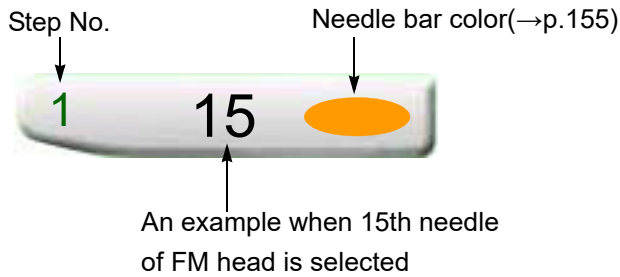

When ESQ-C is mounted, the following display will appear.

When embroidering step 2 by the right device, select "1".

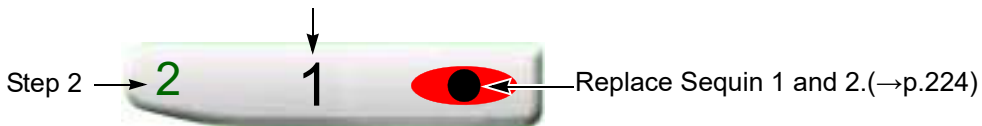

When embroidering step 2 by the left device, select "9". (Example of 9-needle machine)

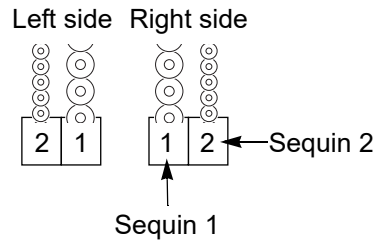

[c] Offset mark

The illustrated example shows that the frame moves to the front after finishing of step 3. However, to move the frame, the setting of "Automatic Offset" is necessary.(→p.176)

[d] Forced start mark

Even if "Auto start at same color" is set to "NO", the machine will start automatically.

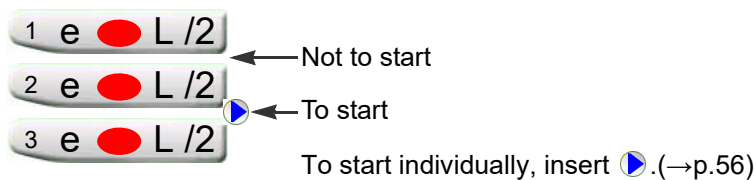

4-2-2. How to operate (not to insert offset mark)

The following is an example of embroidering step 1 at CM head under the below terms.

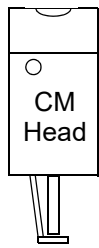

Looper e
 Stitch type: L (Loop stitch)
 Needle height: 5

(1) To open screen

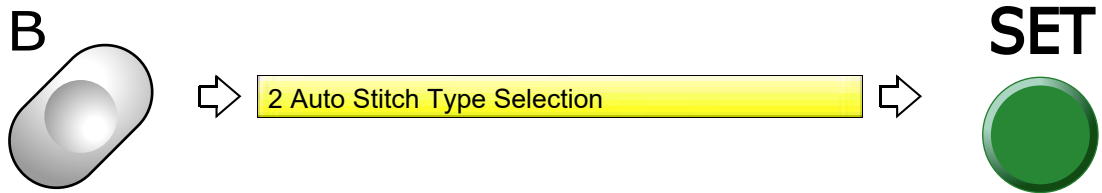

(2) To select the looper e to use at the step 1

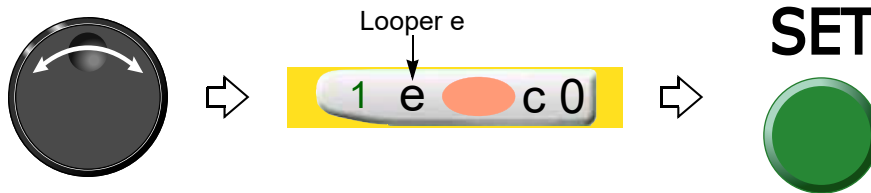

(3) To select stitch type L (Loop stitch)

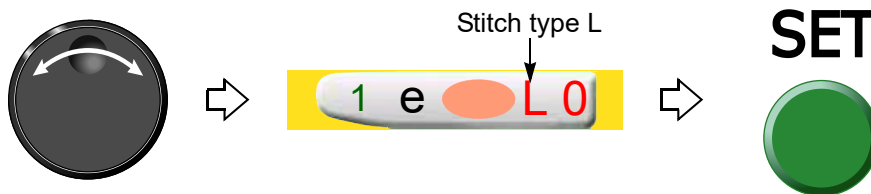

(4) To select needle height 5

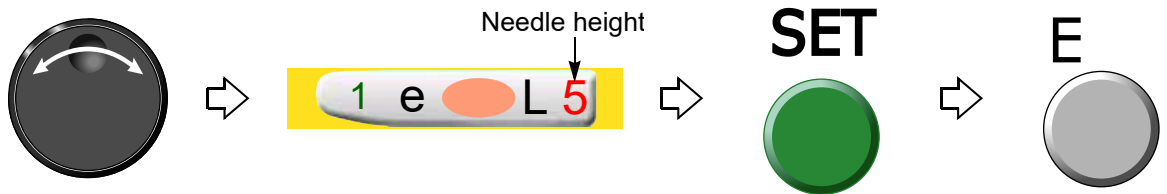

In case of TCMX-mixed type series, after that, the motion when starting the machine is shown as follows.

(a) When it is in the middle of embroidery

When the head selected at Auto Stitch Type Selection is different from the current head, the head will switch automatically after start of the machine, and the frame will move.

(b) When it is not in the middle of embroidery

When the head selected at Auto Stitch Type Selection is different from the current head, the head will switch automatically.

4-2-3. How to operate

The following is an example of setting step 1 to the needle bar No.4.

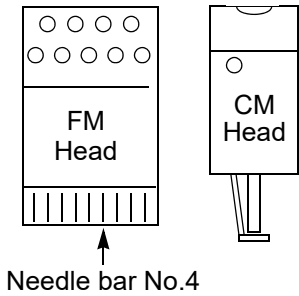

(1) To open screen

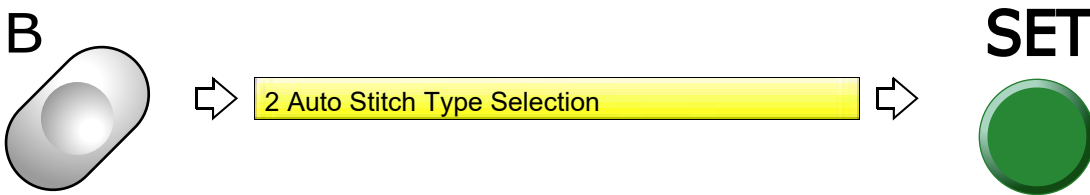

(2) To select the needle bar No.4 to use at the step 1

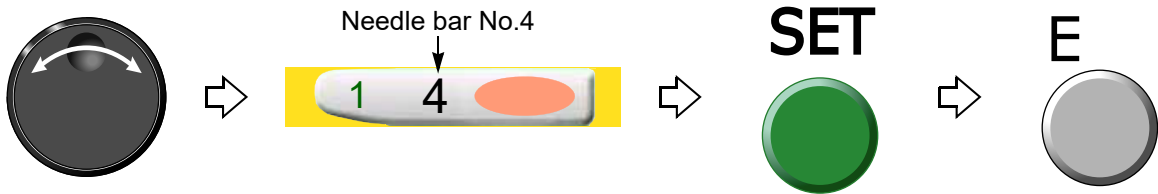

4-2-4. How to operate

The following is an example of inserting the offset mark or the forced start mark between step 2 and step 3.

(1) To select step to insert offset mark



(2) To insert the offset mark

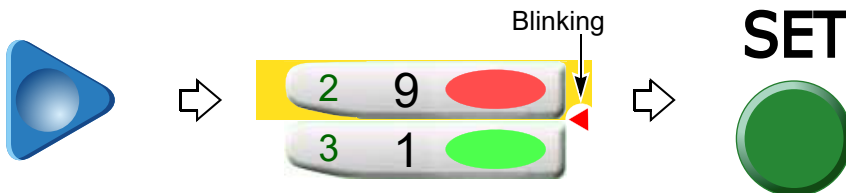

(3) To insert the forced start mark

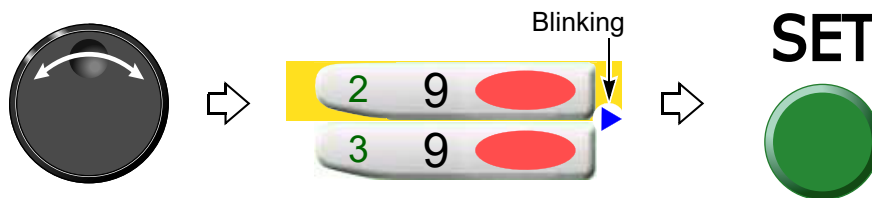

4-3. To change color automatically / to start operation automatically (Auto Color Change "AC" / Auto Start "AS")

4-3-1. Screen

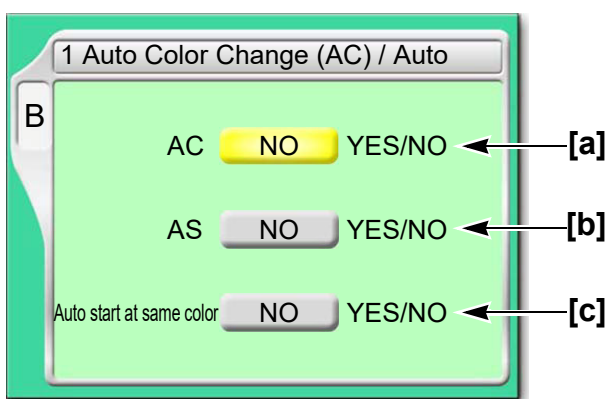

[a] Setting to change color automatically according to Auto Stitch Type Selection

YES: To perform

NO: Not to perform

Selecting NO will select the current stitch type (CM head) or needle bar (FM head) irrespective of "Auto Stitch Type Selection".

In case of TCMX-mixed type series

When [a] is changed from NO to YES in the middle of embroidery or when the head of "Auto Stitch Type Selection" is different from the current head, the frame will move to the neighbor head after start of the machine (fixed interval movement).

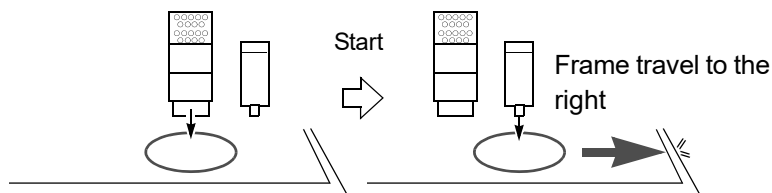

[b] Setting to start operation automatically after color change

YES: To perform

NO: Not to perform

Selecting "NO" will disable the following settings.

[c] Setting to start operation automatically when the same looper or needle bar is selected at the previous and next steps.

YES: To perform

NO: Not to perform

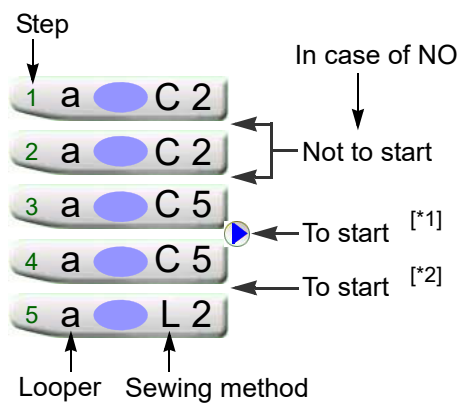

[*1]
To start individually, insert . (→p.56)

[*2]
Different stitch type at the same looper will cause the machine to start.

4-3-2. How to operate

This is an example of setting with the following conditions.

Auto Color Change (AC)

Auto Start (AS)

Automatic Start at the same color

(1) To open screen

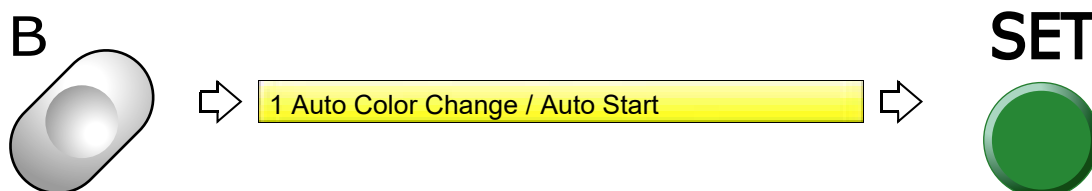

(2) Auto Color Change (AC)

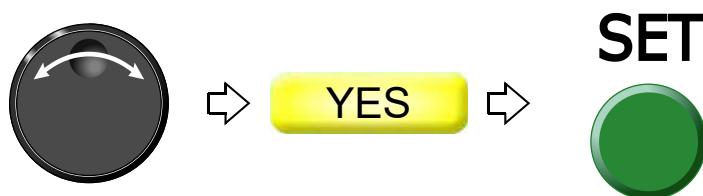

(3) Auto Start (AS)



(4) Automatic Start at the same color



1
2
3
4
5
6
7
8
9
10
11
12

5. Decision of the design start position

5-1. To check design size and setting contents of design (Check of design)

Check setting conditions such as size, scale up/down, repeat, etc of the design to be embroidered from now. Use the checking result as rough standard when deciding the design start position.

For this function, refer to the detail page.(→p.31)

5-1-1. Explanation on the screen

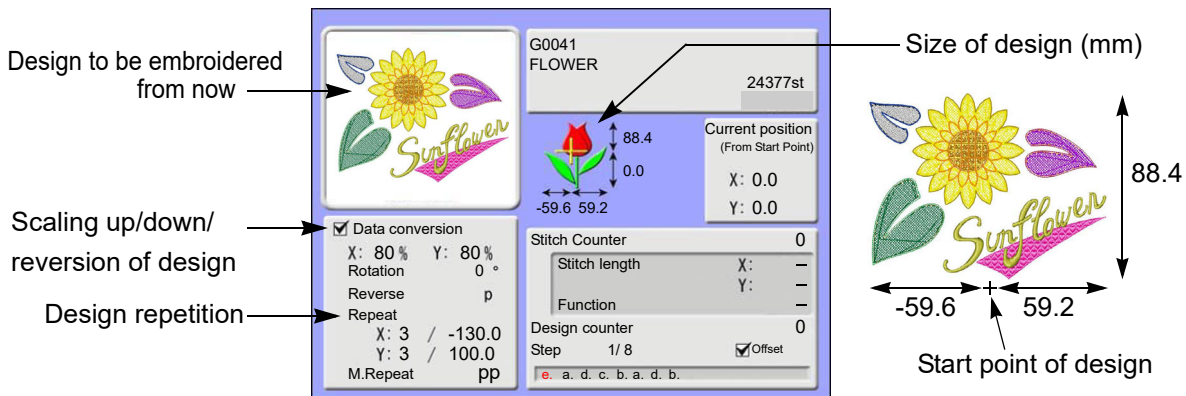

The size after scaling up/down will be displayed with the value based on the design start position. This example shows the size of vertical 88.4 mm and horizontal 118.8 mm.

5-1-2. How to operate

(1) To open screen

Press i key.

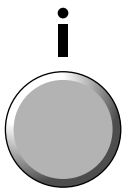

After pressing this key again, setting contents in detail and the code No. occurred up to now can be confirmed.

To return to the main screen, press E key.

5-2. To lower needle bar to adjust frame position (Needle bar operation)

This function is applied for TCMX-mixed type series.

5-2-1. Explanation on the screen



Up: To raise needle bar
Down: To lower needle bar

5-2-2. How to operate



The following is an example of lowering the needle bar.

(1) To open screen

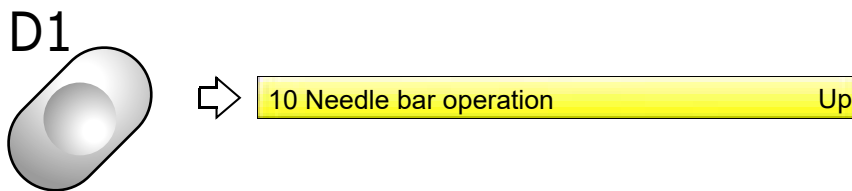

(2) To lower needle bar



5-3. To move frame to the design start position (Manual frame travel)

This operation is unnecessary when the frame has already come to the start position of the design by the operation described previously.

5-3-1. Screen

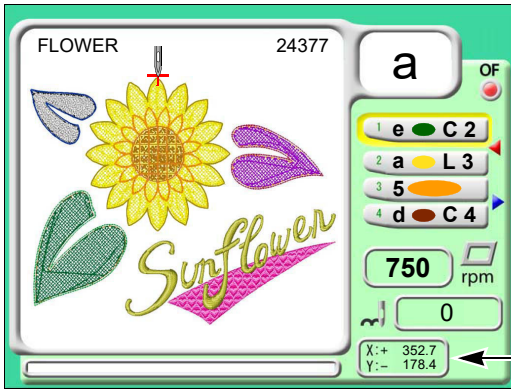

The current frame position is displayed by the numerical value (mm). The frame position is based on the Frame Origin.

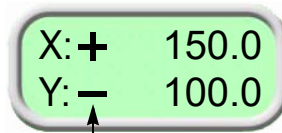

The code (+/-) means the frame travel direction.

[Relation between frame travel direction and code]

- (1) If the frame moves to the rear, the code will be "Y:-".
- (2) If the frame moves to the front, the code will be "Y:+".
- (3) If the frame moves to the right, the code will be "X:-".
- (4) If the frame moves to the left, the code will be "X:+".

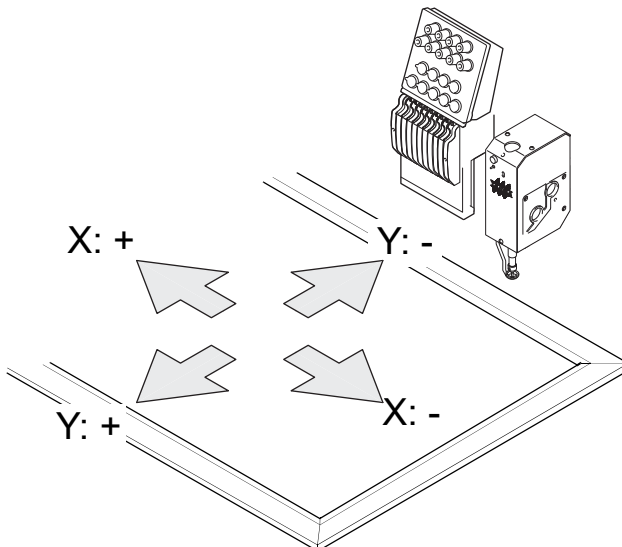

5-3-2. How to operate

There are following two methods.

**(1)** To use Frame Travel key**(a)** Switch to the main screen

Press E key plural times to switch to the main screen.

(b) To move frame to the design start position

Press any desired key. The frame will move.

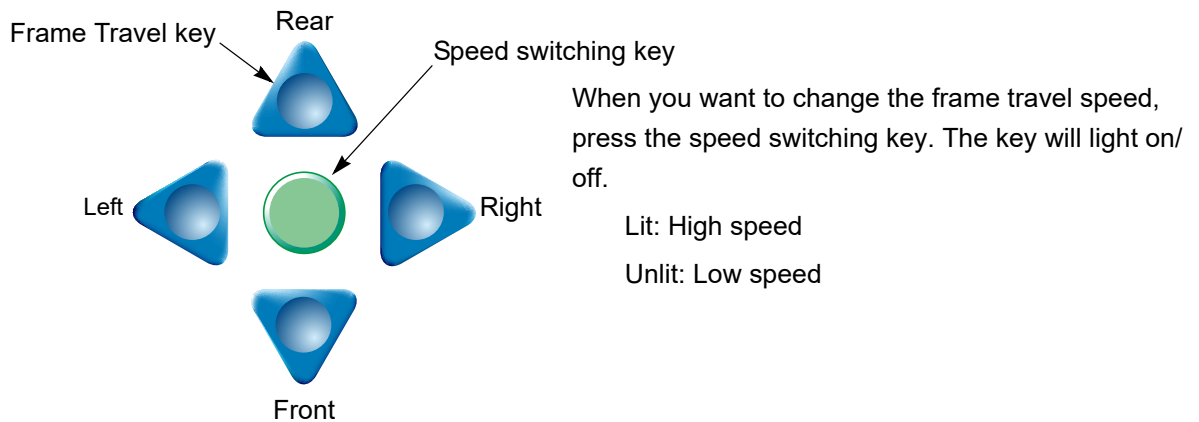
**(2)** To use Jog dial/Jog shuttle**(a)** Switch to the main screen

Press E key plural times to switch to the main screen.

(b) To decide the frame travel direction

Press E key to decide the frame travel direction.

It moves vertically.

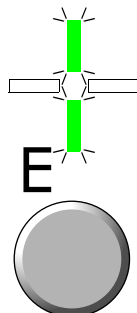

It moves horizontally.

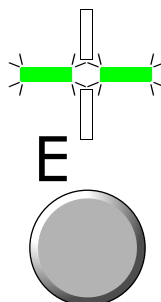

(c) To move frame to the design start position

Turn the jog dial (low speed) / the jog shuttle (high speed). The frame will move.

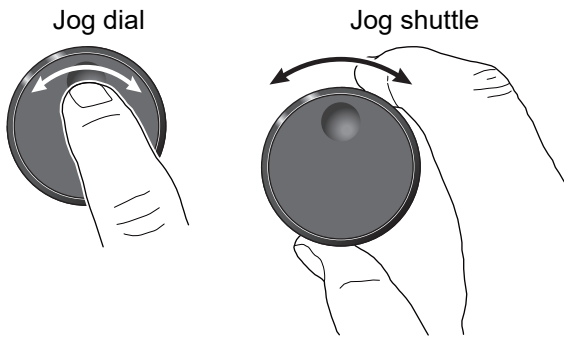

(3) To use Jog remote controller (Option for some models)

(a) Switch to the main screen

Press E key plural times to switch to the main screen.

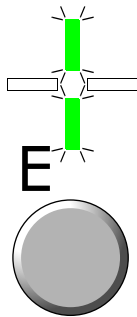

(b) To move frame to the design start position

Tilt the stick. The frame will move.

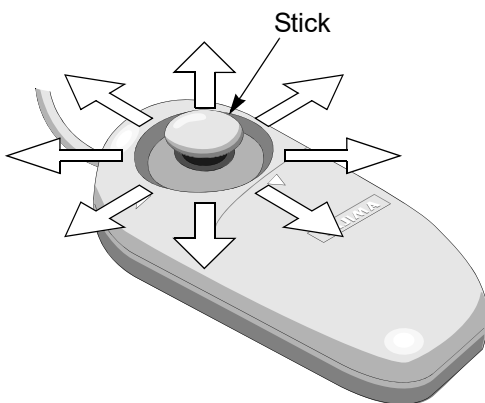

Frame travel speed will be changed by degree of leaning condition of the stick.

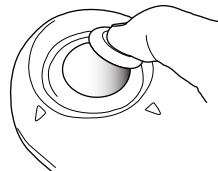

5-4. To check if design fits in embroidery space (Trace)

Since the frame moves according to the size of the design, you can check whether the design fits in the embroidery space or not.

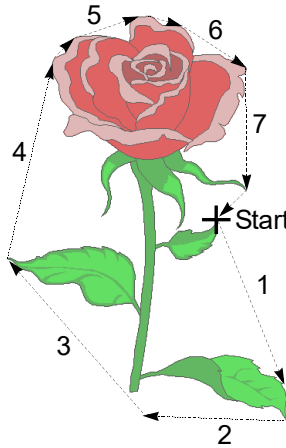

The number in the left figure indicates the orbit of the frame. After completion of trace, embroidering from that position is possible.

When repeat is set

The machine will trace whole designs after tracing the first design.

When Automatic Offset is set

The machine traces according to the setting.

5-4-1. Screen

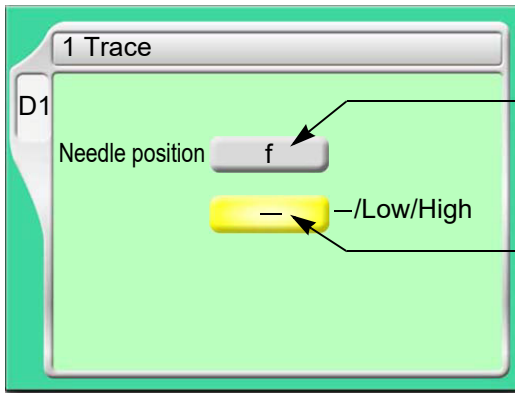

Current looper or Needle bar No.

The frame will move on the basis of this.

Speed of frame travel

Low: Low speed

High: High speed

5-4-2. How to operate

⚠ CAUTION

⊘ When performing this operation, do not put your hands, etc. on the table. Moving the frame could injure you.

The following is an example of executing Trace.

(1) To open screen

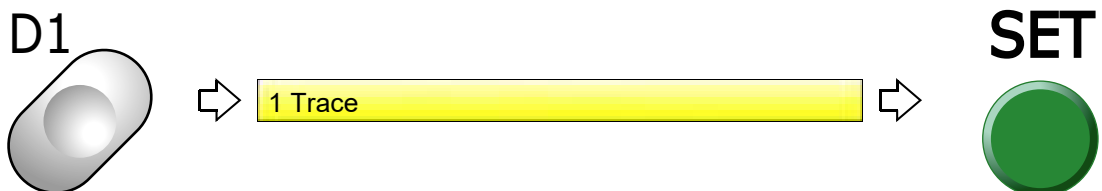

(2) To execute

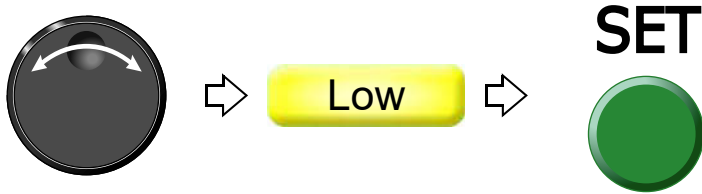

When the tracing is impossible due to the design size exceeding the embroidery space, follow the procedure below after checking the size of the design.

- (a)** The frame will move again after temporary stop.
- (b)** Code No.225 will be displayed.
Press E key.
- (c)** Move the frame to the design start position.
- (d)** Perform tracing again.

To suspend tracing, follow the procedure below.

- (a)** Suspend the operation by the stop switch.
Code No.1C1 will be displayed.
Do not turn OFF the power while the code No.1C1 is displayed.
- (b)** Press E key.
- (c)** After that, follow the message described below.

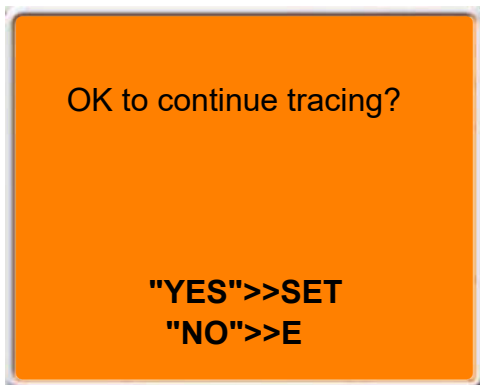

To continue → SET key

To suspend → E key

6. Check items before embroidering

6-1. Maximum speed (Maximum RPM)

The value set here will be the maximum speed of the machine. It is automatically increased/decreased depending on stitch length in the middle of embroidery.

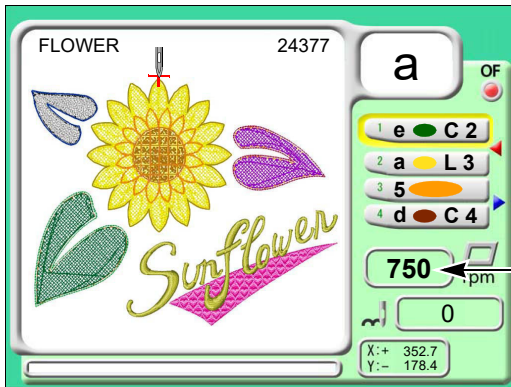

Speed display column

During stop: The maximum speed is displayed.

During operation: Actual operating speed is displayed.

Stitch length	Embroidery speed
Up to 4.0 mm	Maximum speed (A in the right figure)
4.1 mm to 11.9 mm	Automatic change (B in the right figure)
12.0 mm or more	Low speed (C in the right figure)

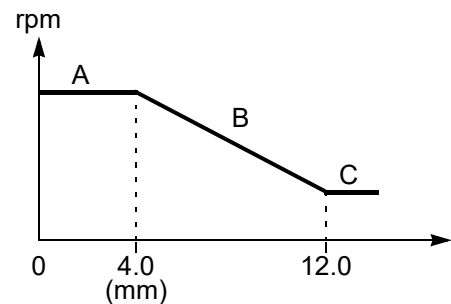

6-1-1. Explanation on the screen

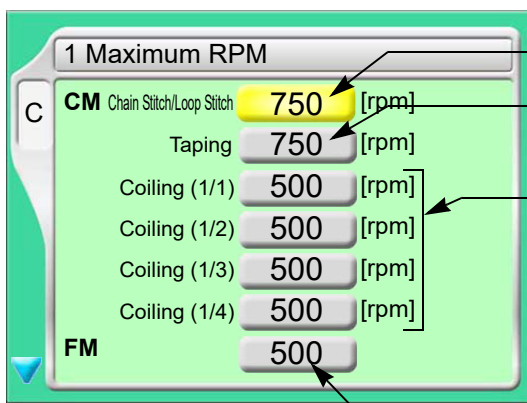

Maximum speed of Chain Stitch and Loop Stitch

Maximum speed of MT-1 (Taping) [*1]

Maximum speed of MT-1 (Coiling) [*1]

[*1] It will be displayed only when MT-1 (Option) is equipped. (→p.213)

TCMX-mixed type series

Maximum speed of FM head

When "N" is displayed, the maximum speed differs in each needle bar. (→p.130)

To apply the same maximum speed to all needle bars, change "N" to a value. When a value is displayed, the same maximum speed is applied to all needle bars.

6-1-2. How to operate

The following is an example to set the maximum speed of CM head.

(1) To open screen

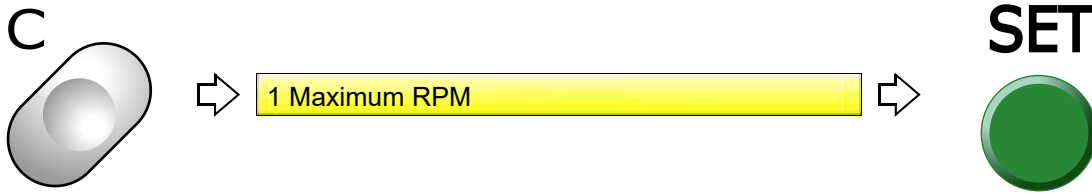

(2) To select maximum speed

Selection of the value exceeding "Max. Revolution Limit" is not possible.



To change the maximum speed during operation of the machine, turn the jog dial / the jog shuttle.

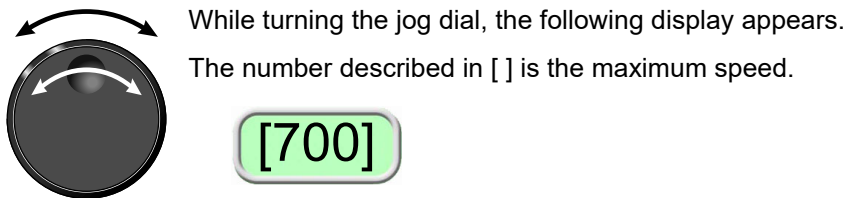

6-2. Embroidery head

6-2-1. CM head

It is possible to embroider only when the toggle switch is turned "ON".

The switch operation during working of the machine is invalid. Even if the switch operation is performed, it will become effective after the machine stops.

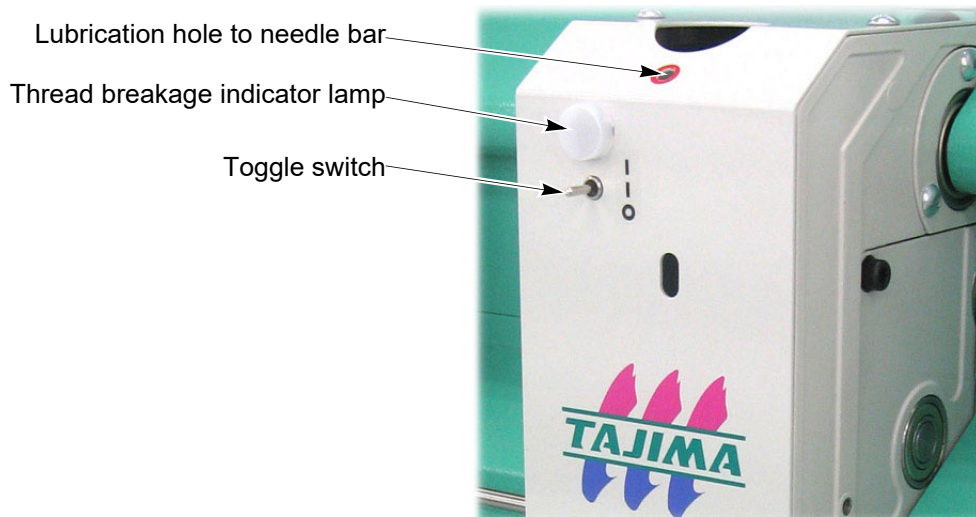

(1) Lubrication hole to needle bar(→p.249)

(2) Thread breakage indicator lamp

Lit in green	Ready to embroider When CM head is selected
Unlit	Embroidery is suspended. When FM head is selected (TCMX-mixed type series)
Blinking in green	Frame back section at the head without thread breakage. The lamp at the head without thread breakage blinks in green during frame back.
Lit in red	Thread Detection
Red/green alternate blinking	During color change or working of ATH in CM head

6-2-2. Toggle switch

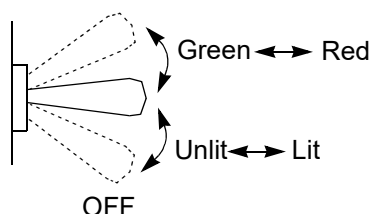

If the switch is turned OFF, the head will suspended, then the nipple and the presser foot will move up.

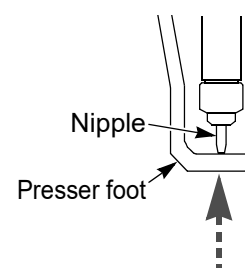

6-2-3. FM head (TCMX-mixed type series)

Check the position of the following tension base switch and needle bar suspension lever before embroidering.

Regarding the tension base switch and the needle bar suspension lever, embroidering is possible only when both of them are set to "ON".

(1) Tension base switch

This switch will suspend the head electrically.

The switch operation during working of the machine is invalid. Even if the switch operation is performed, it will become effective after the machine stops.

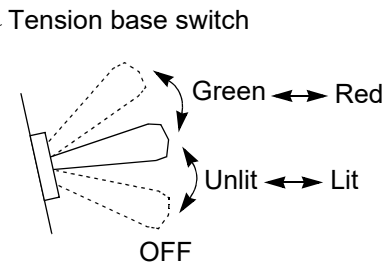

Thread breakage indicator lamp

Lit in green	Ready to embroider
Unlit	Embroidery is suspended. (Needle bar will not move down.) When CM head is selected
Blinking in green	Frame back section at the head without thread breakage. The lamp at the head without thread breakage blinks in green during frame back.
Lit in red	Upper thread breakage
Blinking in red	Under thread breakage

(2) Needle bar suspension lever

This lever will suspend the head mechanically.

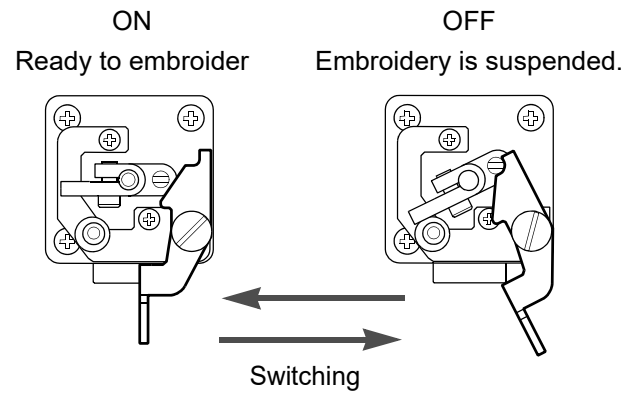
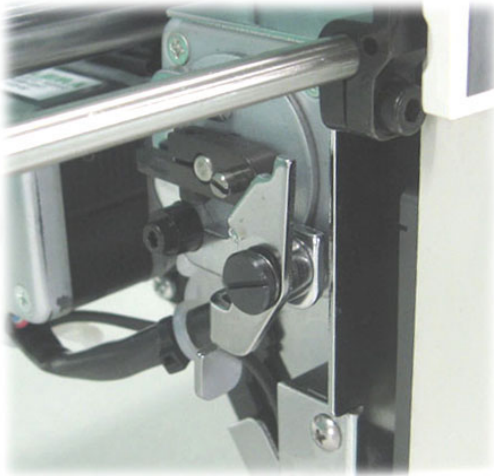

- 1
- 2
- 3
- 4
- 5
- 6
- 7
- 8
- 9
- 10
- 11
- 12

7. Embroidery starts

7-1. Start and stop

⚠ CAUTION

ⓘ Before starting the machine, pay enough attention to the surrounding safety. Moving needle bar and/or frame could injure you.

7-1-1. Bar switch

- (1) When starting the operation, move the bar switch to the right side.
- (2) To stop the machine, move the bar switch to the left side.
- (3) To start slow operation from the state that the machine stops, move the bar to the right side and hold it at the position. Releasing it will change to normal operation.



7-1-2. Start/stop switch

- (1) When starting the operation, press the start switch.
- (2) To stop the machine, press the stop switch.
- (3) To start slow operation, keep on pressing the start switch. Releasing it will start normal operation.

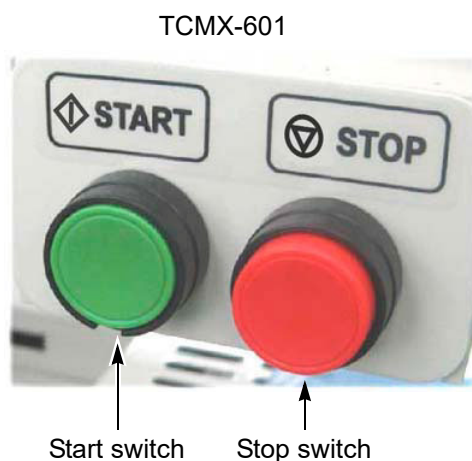

The following switches are equipped in some models.



7-2. Frame Back (to return the frame) / Frame Forward (to advance the frame)

Frame Back

This function will return the frame to the direction of stitches returning in the state that the needle bar is stopped.

Frame Back is performed when thread breaks, and the repair stitches are performed from that position only at the head with thread breakage.



In case of CM head, Frame Back will not be performed when Frame Back function is set to "NO".
(→p.91)

Frame Forward

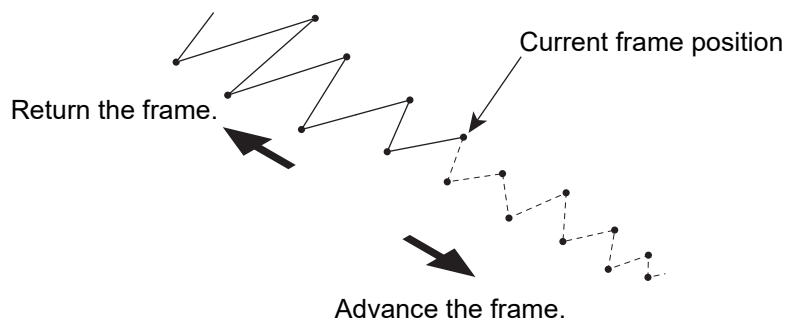
This function will advance the frame to the direction of stitches proceeding in the state that the needle bar is stopped. The frame can be moved immediately to the embroidery start point when you want to start from the middle of embroidery.



7-2-1. Frame Back

 CAUTION
<p> When performing this operation, do not put your hands, etc. on the table. Moving the frame could injure you.</p> <p> Frame Back/Frame Forward with CM head Do not put your hands etc. near needle or on the table. Since the needle will move to activate ATH, you could be injured.</p>

Perform setting of Frame Back.(→p.162)

In case of CM head, Frame Back will not be performed when Frame Back function is set to "NO".(→p.91)

(1) You want to return the frame for 1 stitch.

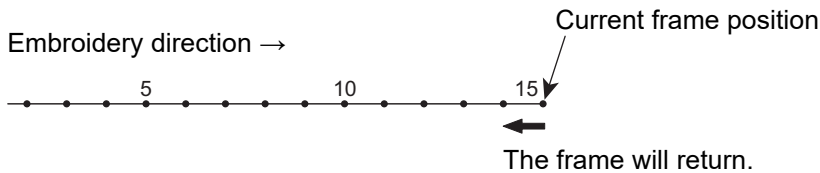

TCMX-601	<p>Press the stop switch one time.</p> <p>After thread trimming, the frame will return for 1 stitch.</p>
TCMX-mixed type, TCMX-mixed type (L), TCMX-600	<p>Move the bar switch to the left and return it to the original position immediately.</p> <p>[When CM head is selected]</p> <p>After thread trimming, the frame will return for 1 stitch.</p> <p>[When FM head is selected]</p> <p>The frame will return for 1 stitch.</p>

(2) You want to return the frame for several (2 to 10) stitches.

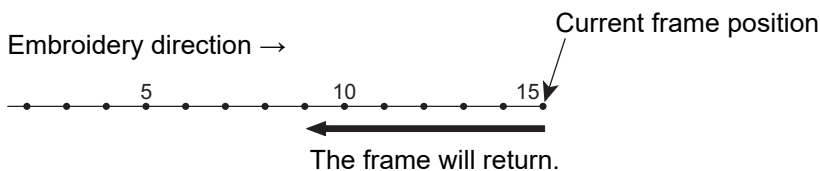

TCMX-601	<p>Keep on pressing the stop switch.</p> <p>After thread trimming, the frame will return by 1 stitch unit.</p> <p>To stop, release the stop switch.</p>
----------	---

TCMX-mixed type, TCMX-mixed type (L), TCMX-600	<p>Move the bar switch to the left, and hold it at that position.</p> <p>[When CM head is selected]</p> <p>After thread trimming, the frame will return by 1 stitch unit.</p> <p>To stop, return the bar switch to the original position.</p> <p>[When FM head is selected]</p> <p>The frame will return by 1 stitch unit.</p> <p>To stop, return the bar switch to the original position.</p>
--	--

(3) You want to return the frame for 11 stitches or more.

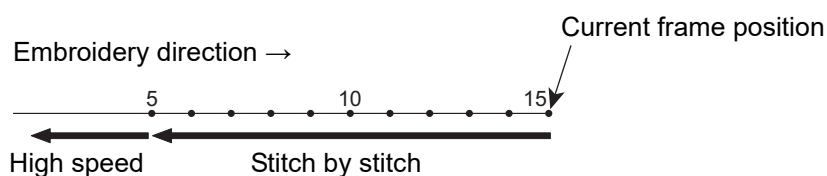

TCMX-601	<p>Keep on pressing the stop switch.</p> <p>The frame will return by 1 stitch unit up to 10 stitches. For 11 stitches or more, the frame will return at high speed.^[*1]</p> <p>To stop, press the stop switch again.</p>
TCMX-mixed type, TCMX-mixed type (L), TCMX-600	<p>Move the bar switch to the left, and hold it at that position.</p> <p>[When CM head is selected]</p> <p>After thread trimming, the frame will return by 1 stitch unit up to 10 stitches. For 11 stitches or more, the frame will return at high speed.^[*1]</p> <p>Returning to the original position will not stop the operation.</p> <p>To stop, move it to the left again.</p> <p>[When FM head is selected]</p> <p>The frame will return by 1 stitch unit up to 10 stitches. For 11 stitches or more, the frame will return at high speed.^[*1]</p> <p>Returning to the original position will not stop the operation.</p> <p>To stop, move it to the left again.</p>

[*1] For 11 stitches or more, the frame will return in units of the number of stitches being set.
(→p.165)

7-2-2. Frame Forward

⚠ CAUTION
<p>⊘ When performing this operation, do not put your hands, etc. on the table. Moving the frame could injure you.</p> <p>⊘ Frame Back/Frame Forward with CM head Do not put your hands etc. near needle or on the table. Since the needle will move to activate ATH, you could be injured.</p>

Perform setting of Frame Forward.(→p.162)

(1) You want to advance the frame for 1 stitch.

[For CM head]

To perform Frame Forward in the middle of embroidery, perform manual thread trimming before performing Frame Forward.

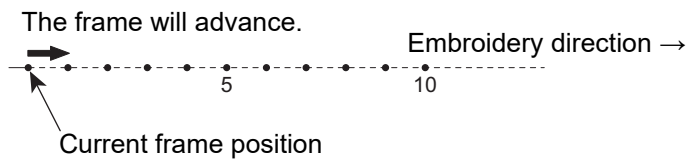

TCMX-601	<p>Press the stop switch one time.</p> <p>The frame will advance for 1 stitch. For 11 stitches or more, the frame will return at high speed. [*1]</p> <p>To stop, press the stop switch again.</p>
TCMX-mixed type, TCMX-mixed type (L), TCMX-600	<p>Move the bar switch to the left, and hold it at that position.</p> <p>The frame will advance by 1 stitch unit up to 10 stitches.</p>

(2) You want to advance the frame for several (2 to 10) stitches.

[For CM head]

To perform Frame Forward in the middle of embroidery, perform manual thread trimming before performing Frame Forward.

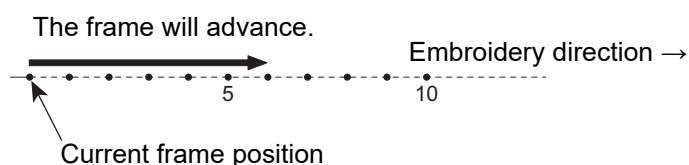

TCMX-601	<p>Keep on pressing the stop switch.</p> <p>The frame will advance by 1 stitch unit.</p> <p>To stop, release the stop switch.</p>
TCMX-mixed type, TCMX-mixed type (L), TCMX-600	<p>Move the bar switch to the left, and hold it at that position.</p> <p>The frame will advance by 1 stitch unit.</p> <p>To stop, return the bar switch to the original position.</p>

(3) You want to advance the frame for 11 stitches or more.

[For CM head]

To perform Frame Forward in the middle of embroidery, perform manual thread trimming before performing Frame Forward.

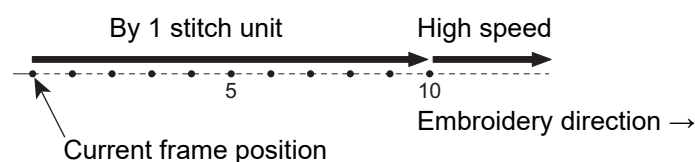

TCMX-601	<p>Keep on pressing the stop switch.</p> <p>After thread trimming, the frame will advance by 1 stitch unit up to 10 stitches. For 11 stitches or more, the frame will return at high speed.^[*1]</p> <p>To stop the machine, press the stop switch again.</p>
TCMX-mixed type, TCMX-mixed type (L), TCMX-600	<p>Move the bar switch to the left, and hold it at that position.</p> <p>The frame will advance by 1 stitch unit up to 10 stitches. For 11 stitches or more, the frame will advance at high speed.^[*1]</p> <p>Returning to the original position will not stop the operation.</p> <p>To stop, move it to the left again.</p>

[*1] For 11 stitches or more, the frame will return in units of the number of stitches being set.
(→p.165)

7-3. Handling of thread breakage

7-3-1. CM head

The machine will stop automatically and will be in the following condition.

- (1) The lamp of the head with thread breakage will be lit in red.

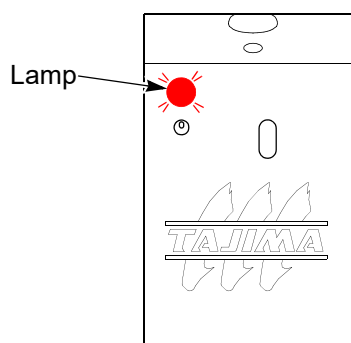

- (2) Code No. (number indicating stop factor) will be displayed on the operation panel.

[291]: Thread is broken

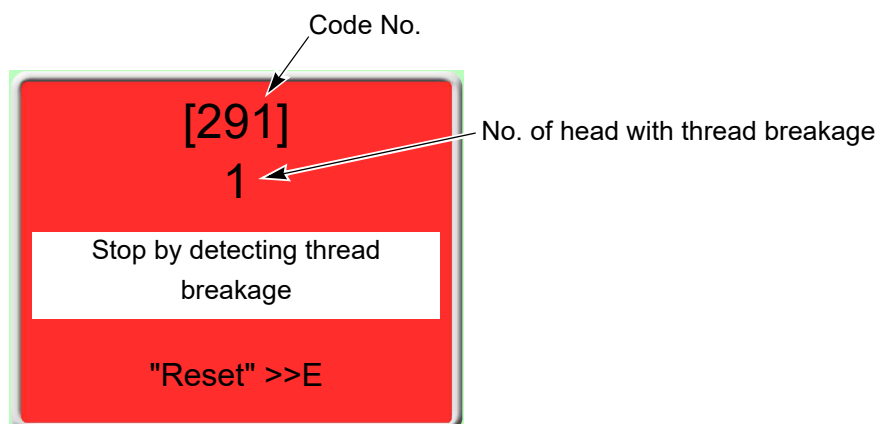

- (3) Pass the thread. Regarding how to pass the thread, refer to the detail page.(→p.39)

(4) Start the operation after performing Frame Back by several stitches.

Starting stitches after Frame Back differ between the head with thread breakage and the head without thread breakage.

[Head with thread breakage]

The machine restarts embroidering from the position where Frame Back stopped (1 in the figure below). As a result, repair stitches will be performed at the position 2 with missing stitches due to thread breakage.

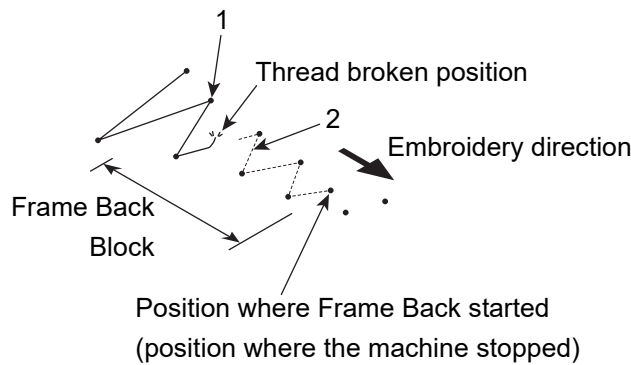

[Head without thread breakage]

The machine restarts embroidering from the position where Frame Back started. This example is for the case "Frame Back Function" is set to "0".(→p.91)

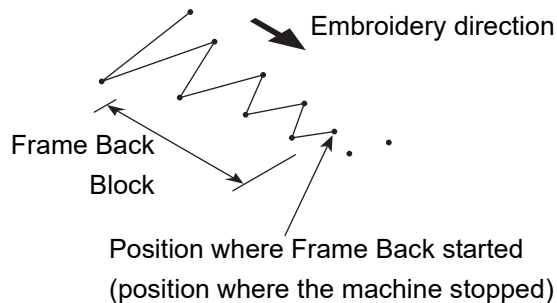

To make the head without thread breakage embroider from the position where Frame Back is stopped, set the tension base switch of that head to the "Top" once before starting operation. (When you release the switch, it will return to the original position.)

Toggle switch

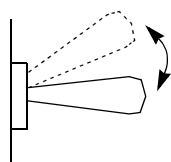

Thread breakage indicator lamp will change color from green to red.

7-3-2. FM head (TCMX-mixed type series)

The machine will stop automatically and will be in the following condition.

(1) The thread breakage indicator lamp lights in red or blinks in green.

Lit in red: Upper thread has broken.

Blinking in red: Under thread has broken.

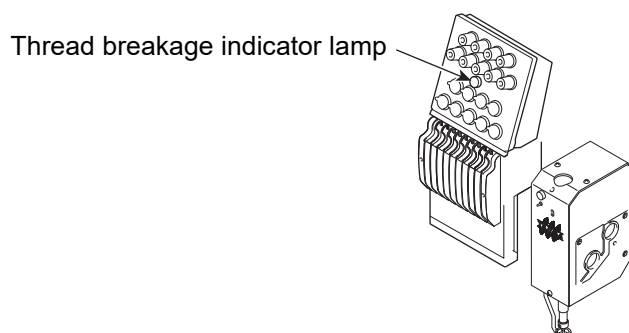
**(2)** Code No. (number indicating stop factor) will be displayed on the operation panel.

[291]: Upper thread has broken.

[293]: Under thread has broken.

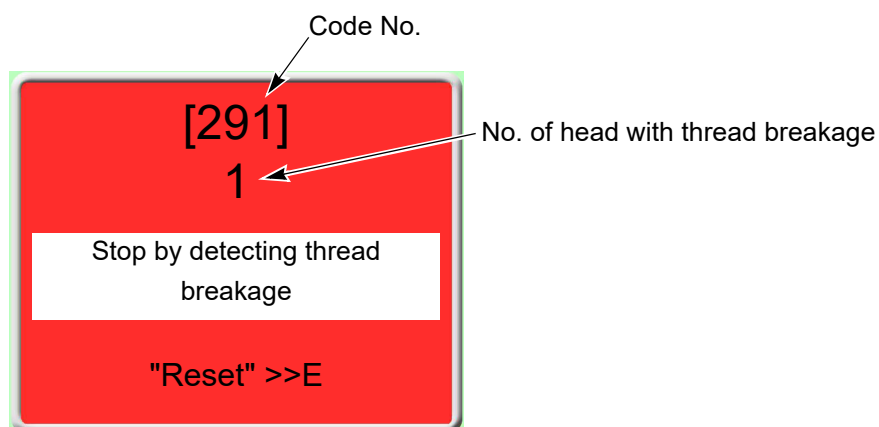

Restart the embroidery by the following procedure.

- (3)** Thread the needle, or change the under thread (bobbin case).

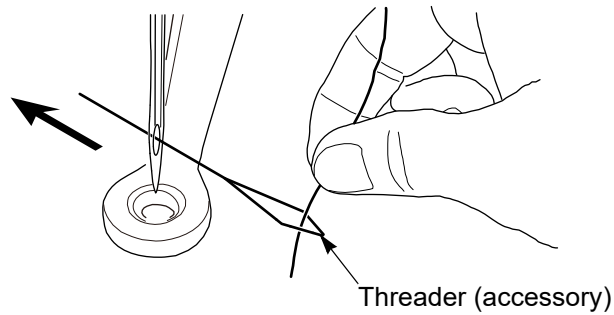

Attaching to rotary hook

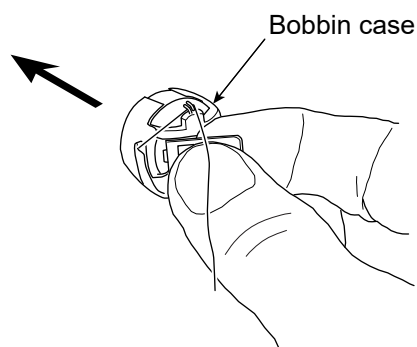

- (4)** Start the operation after performing Frame Back by several stitches.

Starting stitches after Frame Back differ between the head with thread breakage and the head without thread breakage.

[Head with thread breakage]

The machine restarts embroidering from the position where Frame Back stopped (1 in the figure below). As a result, repair stitches will be performed at the position 2 with missing stitches due to thread breakage.

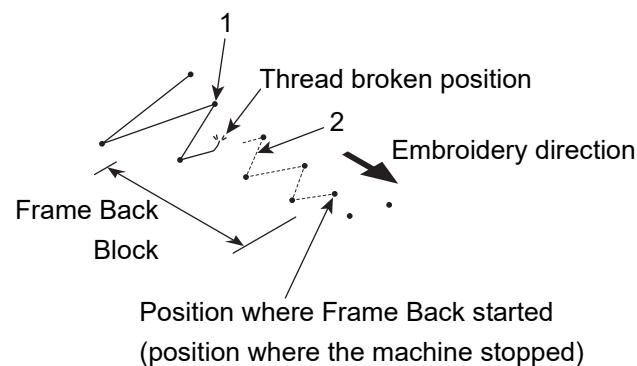

[Head without thread breakage]

The machine restarts embroidering from the position 3 next to where frame back started. This example is for the case "Frame Back All head Sew" is set as "0".(→p.166)

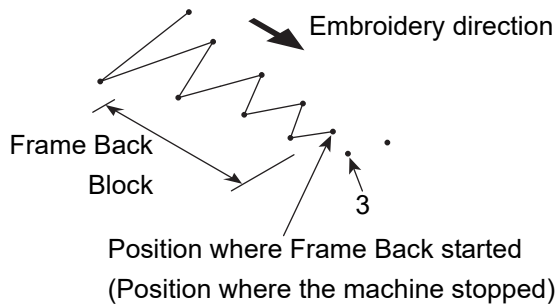

To make the head without thread breakage embroider from the position where frame back is stopped, set the tension base switch of the head to the "Top" once (when you release the switch, it will return to the original position).

Tension base switch

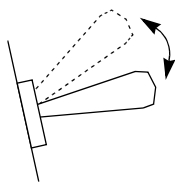

Thread breakage indicator lamp will change color from green to red.

7-4. Completion of embroidery

Destination of the frame movement differs depending on setting of the machine.

Setting of Automatic Offset	
Yes	No
<p>The frame will move to the offset start position.</p>	<p>The frame will not move.</p> <p>However, when Auto Origin Return is set, the frame will move to the design start position</p>

Chapter 5

Functions concerning CM head

1. Related to needle and looper.....	84
2. Related to stitching	88
3. M-axis of MT-1 (Bobbin) (Option)	93

1

2

3

4

5

6

7

8

9

10

11

12

1. Related to needle and looper

1-1. To change the needle height temporarily (Manual Needle Height Selection)

In case of TCMX-mixed type series, this operation is effective only when CM head is selected.

To perform embroidery with the value set here, set "Auto Color Change" to "NO".

1-1-1. Explanation on the screen



↑
Needle height

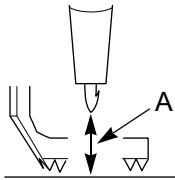

Needle height	0	1	2	3	4	5	6	7	8	9	H
Value (mm) A in the figure	2	2.3	2.6	2.9	3.2	3.5	3.8	4.1	4.4	4.7	[*1]

[*1] If H is selected, the nipple and the presser foot will be at the upper position.

1-1-2. How to operate

CAUTION

When performing this operation, do not put your hands etc. near the needle. Moving up/down of the needle could injure you.

The following is an example of setting the needle height to "4".

(1) To open screen

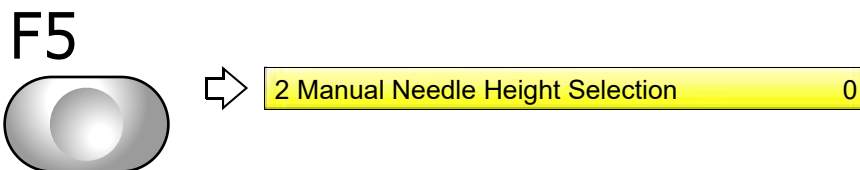

(2) To select the value

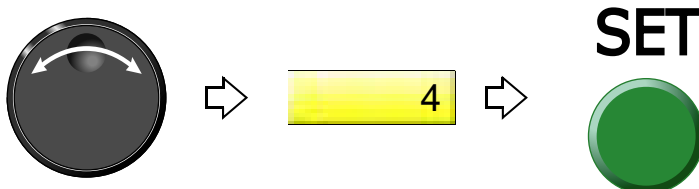

1-2. To return D-axis and the looper to the origin (D-axis Origin Return)

Performing this operation will return D-axis and the looper to the origin. (After Data Set)

D-axis Origin: The hook part of sewing needle faces the front.

Looper Origin: The hole of the looper is located at the back.

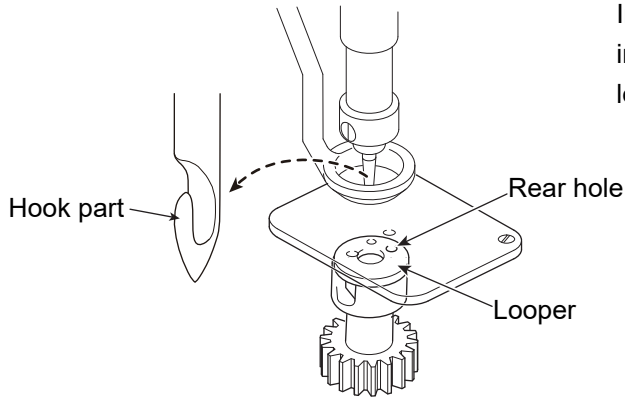

In case threading is performed in this condition, insert the threader into the rear hole of the looper.

In case of TCMX-mixed type series, this operation is effective only when CM head is selected.

1-2-1. Explanation on the screen



↑
D-axis Origin Return
○ : To execute

1-2-2. How to operate

The following is an example of executing D-axis Origin Return.

(1) To open screen

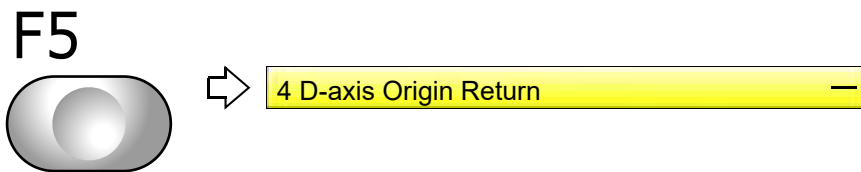

(2) To execute

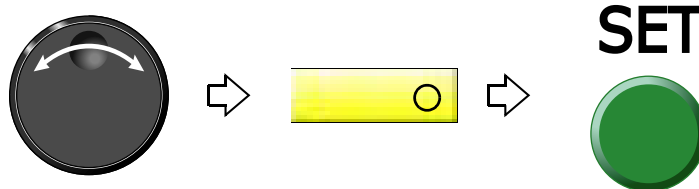

1-3. To return the looper to the fixed position (Looper Fixed Position Return)

Performing this operation will return the looper to the fixed position. (After stopping by switch or after detecting thread breakage)

Looper Fixed Position: The hole of the looper is located at the front.

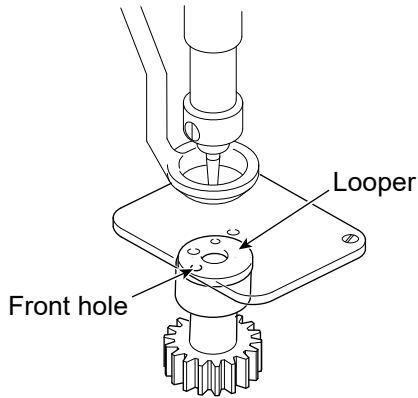

In case threading is performed in this condition, insert the threader into the front hole of the looper.

In case of TCMX-mixed type series, this operation is effective only when CM head is selected.

1-3-1. Explanation on the screen



↑
Looper Fixed Position Return

○ : To execute

1-3-2. How to operate

The following is an example of executing Looper Fixed Position Return.

(1) To open screen

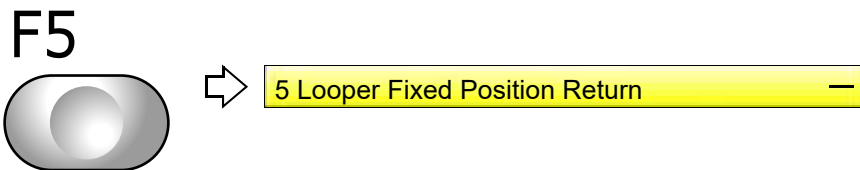

(2) To execute

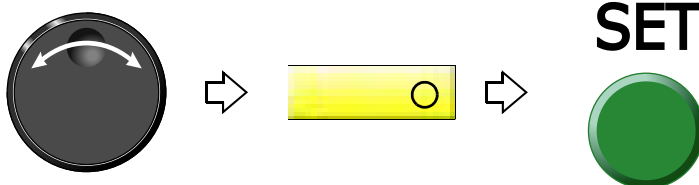

1-4. To move up/down the needle and the nipple manually

Switch the nipple height of all heads by manual operation. There are 2 steps in switching.

To move up/down an individual head, turn OFF/ON the toggle switch.

In case of TCMX-mixed type series, this operation is effective only when CM head is selected.

⚠ CAUTION

⊘ When performing this operation, do not put your hands etc. near the needle. Moving up/down of the needle and the nipple could injure you.

1-4-1. How to operate

- (1) Set to the main screen.
- (2) Press E key while pressing SET key.

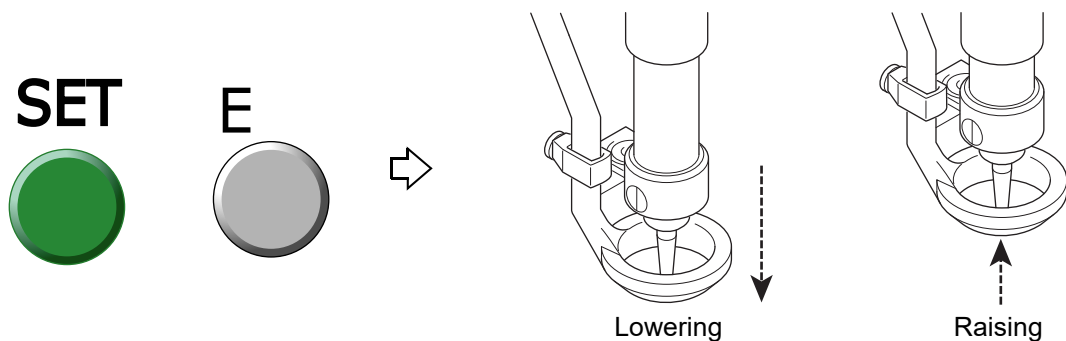

2. Related to stitching

2-1. To change stitch type temporarily (Manual Stitch Type Selection)

To perform embroidery with the value set here, set "Auto Color Change" to "NO".

In case of TCMX-mixed type series, this operation is effective only when CM head is selected.

2-1-1. Explanation on the screen



↑
Sewing method

L: Loop

C: Chain

M: MT-1 (Coiling)^[*1]

T: MT-1 (Taping)^[*1]

[*1] "M" and "T" will be displayed only when MT-1 (option) is equipped.(→p.213)

2-1-2. How to operate

The following is an example of changing from L (Loop) to C (Chain).

(1) To open screen

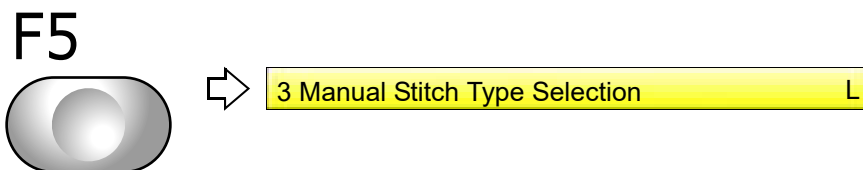

(2) To select C (Chain)

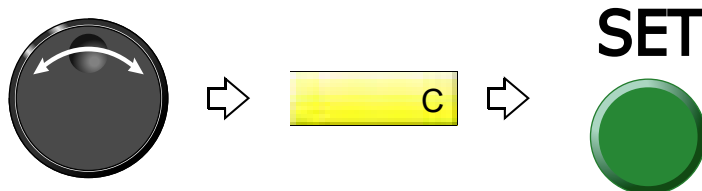

2-2. Setting to prevent a fray of the thread (Number of Tie Stitches)

Set the number of stitches for Tie Stitching (Chain Stitch) to prevent a fray of the thread.

This function is performed only at thread trimming of Loop Stitches (In case of manual thread trimming, Tie Stitching will not be performed). In the middle of embroidery, it is not possible to set the number of stitches exceeding the remaining number of stitches from the position to thread trimming position.

2-2-1. Explanation on the screen



↑
Number of Tie Stitches
NO: Not to perform Tie Stitching
1 to 9: Number of Tie Stitches

2-2-2. How to operate

The following is an example of setting Number of Tie Stitches to "5".

(1) To open screen

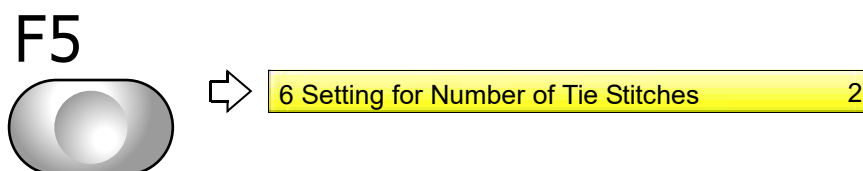

(2) To select Number of Tie Stitches

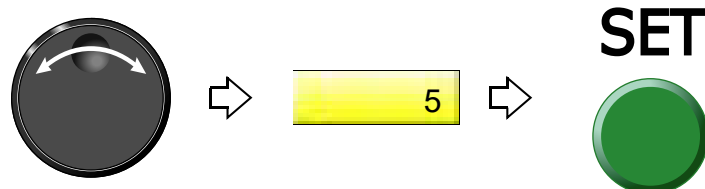

1
2
3
4
5
6
7
8
9
10
11
12

2-3. Setting to prevent a fray of the thread (Thread Management After Trimming)

This setting selects whether cut end of thread after thread trimming is pulled out onto the fabric or not to prevent a fray of the thread.

This setting is effective only in case of color change with frame travel such as jumping and at the end of embroidery. It is invalid in case of color change without frame travel.

2-3-1. Explanation on the screen



↑
Thread management type

Down: To push down under the fabric

Up1: To pull thread on the fabric

Up2: To pull thread on the fabric and take off thread from the needle

2-3-2. How to operate

The following is an example of setting Thread Management After Trimming to "Up2".

(1) To open screen

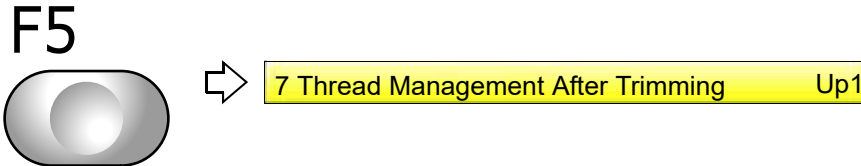

(2) To select thread management type

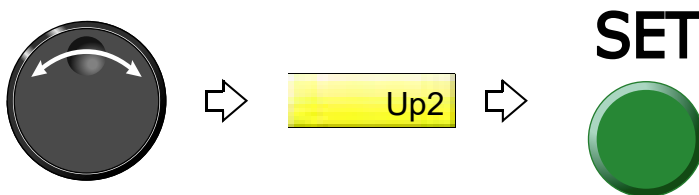

2-4. Frame Back Function (TCMX-601)

This function set to "Frame Back is available / not available". When "NO" is selected, Frame Back will not be performed even if the stop switch or the operation panel is operated.

2-4-1. Explanation on the screen



↑
Frame Back Setting
NO: Frame Back is not available
All: Frame Back is available

2-4-2. How to operate

The following is an example of setting to "Frame Back is available".

(1) To open screen

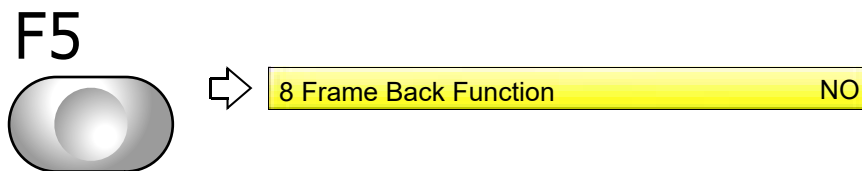

(2) Frame Back is available.



1
2
3
4
5
6
7
8
9
10
11
12

2-5. Frame Back Function (TCMX-600 with 2 or more heads, TCMX-Mix series)

Set to "Frame Back is available / not available" and set the start point of embroidery at the head without thread breakage after Frame Back. All sections at the head with thread breakage are embroidered.

When "NO" is selected, Frame Back will not be performed even if the stop switch or the operation panel is operated.

2-5-1. Explanation on the screen



↑
Frame Back Setting

NO: Frame Back is not available

0: Not to embroider whole section^[*1]

1 to 9: To embroider from the middle^[*1]

Number of stitches from Frame Back Start Point

All: To embroider whole section^[*1]

[*1] The head without thread breakage is applied.

2-5-2. How to operate

The following is an example of setting the start point of embroidery at the head without thread breakage to "3".

(1) To open screen

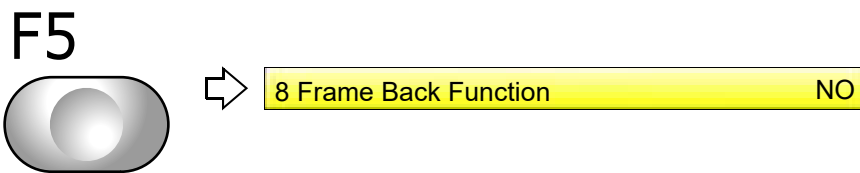

(2) To select the start point of embroidery at the head without thread breakage

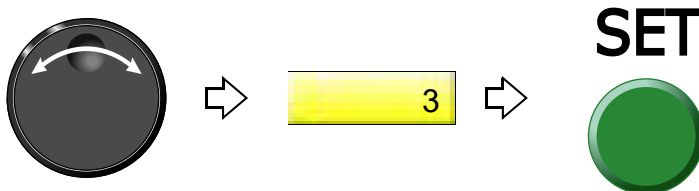

3. M-axis of MT-1 (Bobbin) (Option)

3-1. To rotate M-axis by manual operation

In case of TCMX-mixed type series, this operation is effective only when CM head is selected.

! CAUTION

⊘ When performing this operation, do not put your hands etc. near the needle. Rotating bobbin could injure you.

3-1-1. How to operate

(1) Set to the main screen.

(2) Turn the jog shuttle or jog dial while pressing SET key. The bobbin will rotate to the rotating direction of the shuttle.

It is possible to start the machine from the position after rotating the bobbin. This operation is effective only when CM head is selected.

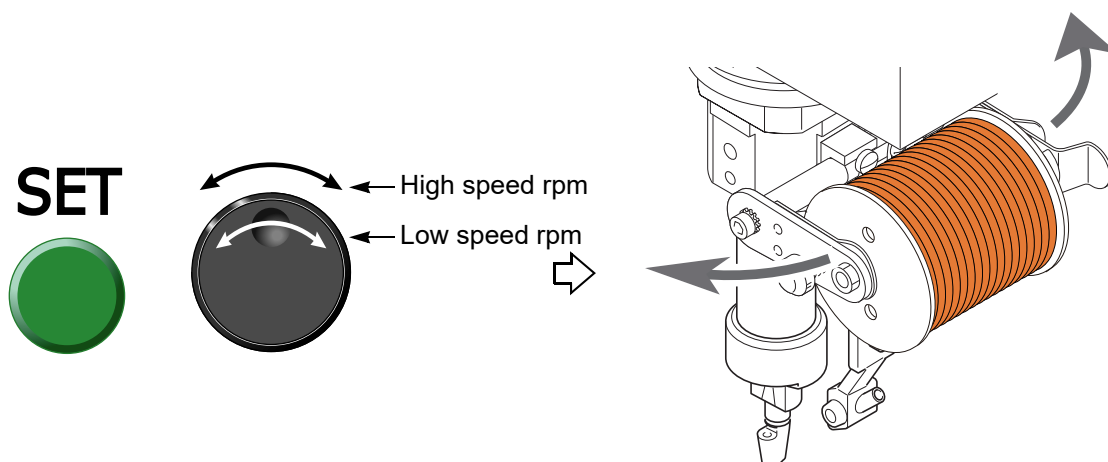

3-2. To return M-axis to the origin by manual operation (Manual M-axis Origin Return)

The origin is the position where the bobbin rotates and stops just after data set and at thread breakage. (Stand-by position)

3-2-1. Explanation on the screen

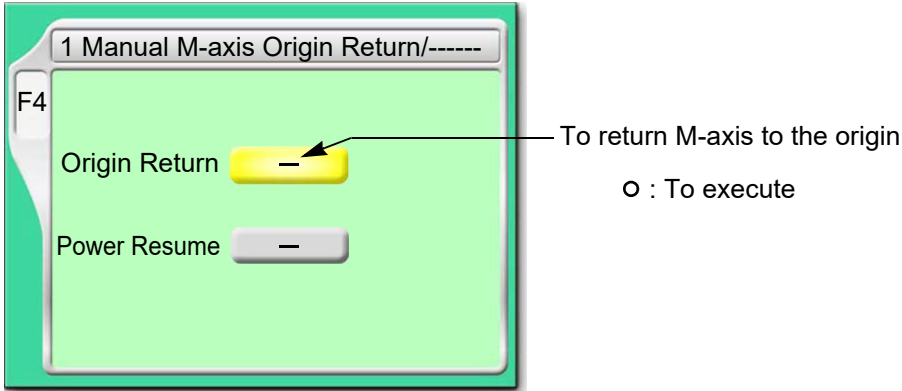

3-2-2. How to operate

! CAUTION

When performing this operation, do not put your hands etc. near the needle. Rotating bobbin could injure you.

The following is an example of executing Manual M-axis Origin Return.

(1) To open screen

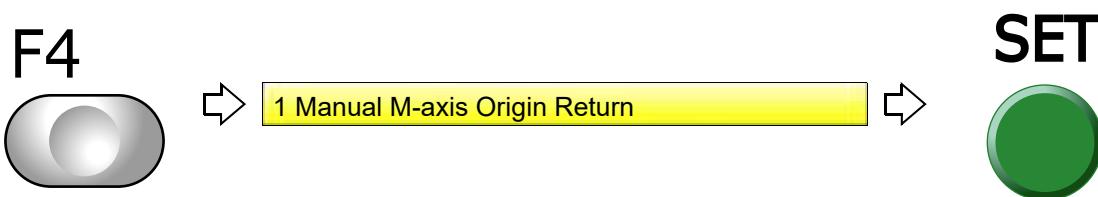

(2) To execute

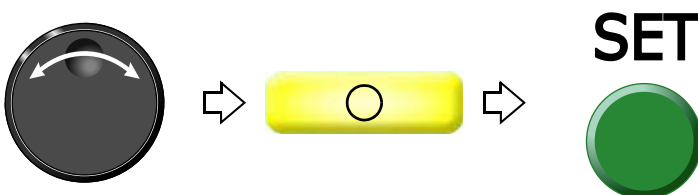

3-3. To return M-axis to the previous position by manual operation (Manual M-axis Power-ON Restore)

When detected angle of bobbin is misaligned, this operation returns the bobbin to the previous angle before misalignment by manual operation.

Use this function in such a case as when M-axis is misaligned due to turning of the bobbin by hand at power turned OFF. It is effective only when misaligned angle against the correct angle is less than 180°.

3-3-1. Explanation on the screen

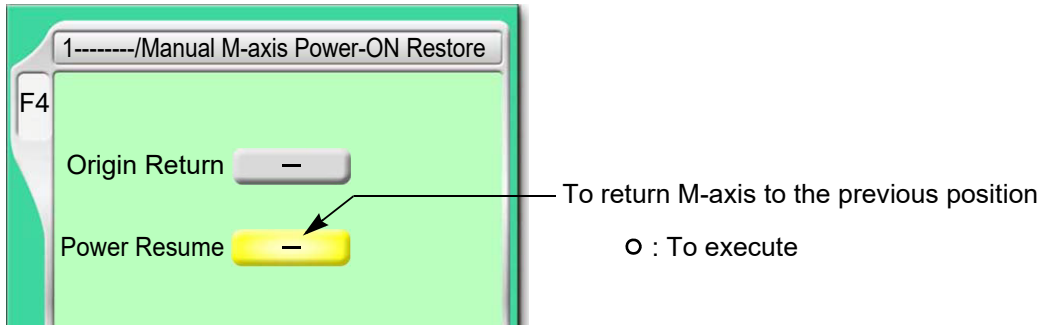

3-3-2. How to operate

CAUTION

When performing this operation, do not put your hands etc. near the needle. Rotating bobbin could injure you.

The following is an example of executing Manual M-axis Power-ON Restore.

(1) To open screen

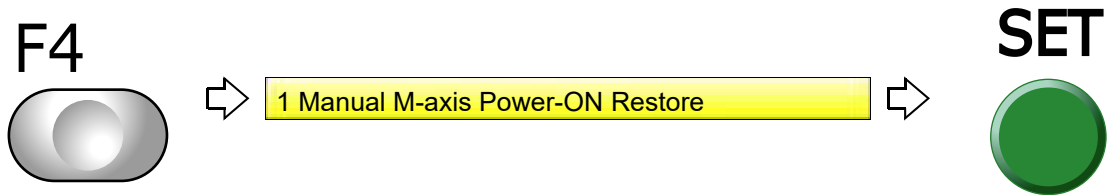

(2) To select Power Resume

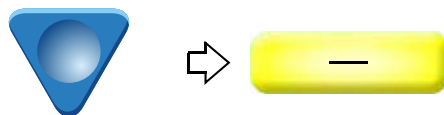

(3) To execute

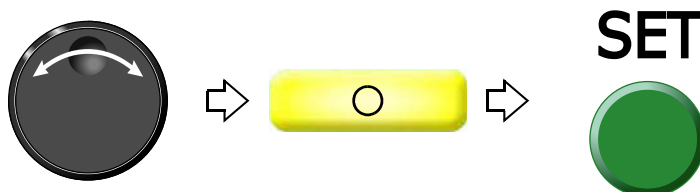

3-4. To set stand-by position of M-axis (M-axis Origin Offset)

Stand-by position is the position where the bobbin rotates and stops just after data set and at thread breakage.

3-4-1. Explanation on the screen

2 M-axis Origin Offset 0°

↑
It shows M-axis angle (direction of bobbin).

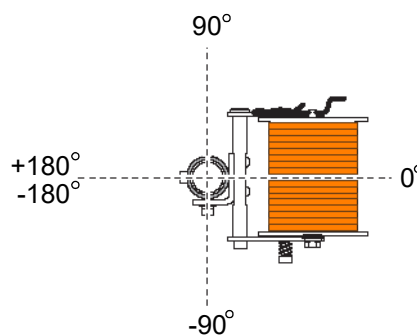

3-4-2. How to operate

The following is an example of setting M-axis Origin Offset to +180°.

(1) To open screen

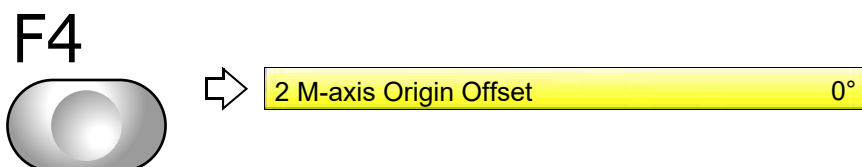

(2) To select the value

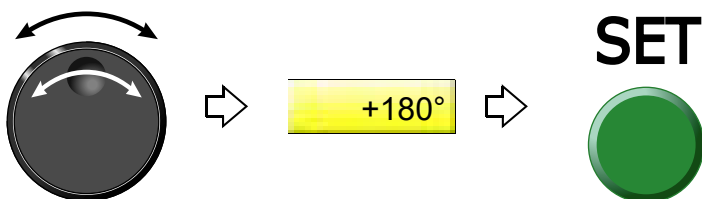

3-5. To set M-axis Retract Position (M-axis Retract Position)

Retract position means the direction of the bobbin at the suspended head (of which the thread breakage indicator lamp is unlit).

3-5-1. Explanation on the screen



↑ It shows M-axis angle (direction of bobbin).

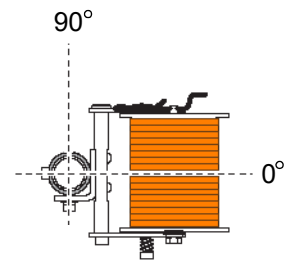

3-5-2. How to operate

The following is an example of setting M-axis Retract Position to 90°.

(1) To open screen

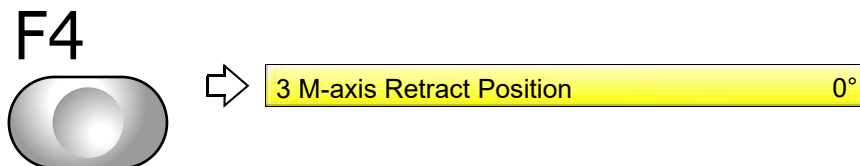

(2) To select the value

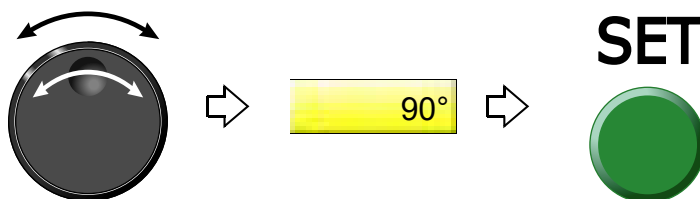

3-6. To return M-axis to the stand-by position after data set
(M-axis Origin Search at Data Setting)

This setting detects M-axis angle after data set and returns the bobbin to the stand-by position.

3-6-1. Explanation on the screen



↑
M-axis Origin Search
YES: To perform
NO: Not to perform

3-6-2. How to operate

The following is an example of setting M-axis Origin Search at Data Setting.

- (1) Set to the main screen.
- (2) Press F6 key while pressing SET key.

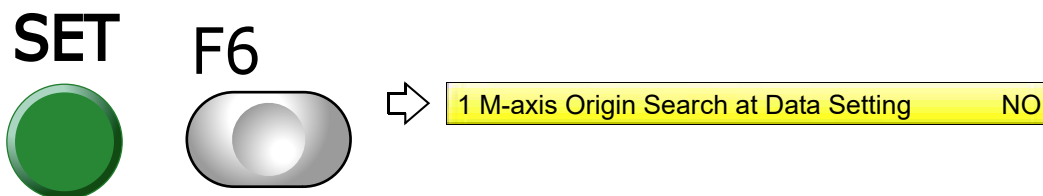

- (3) To set



3-7. To return M-axis to the previous position when the power is turned ON (Auto M-axis Power-ON Restore)

This setting returns bobbin to the correct angle (previous position) by detecting M-axis angle when the power is turned ON.

Use this function in such a case as when M-axis is misaligned due to turning of the bobbin by hand at power turned OFF. It is effective only when misaligned angle against the correct angle is less than 180°.

3-7-1. Explanation on the screen



3-7-2. How to operate

The following is an example of setting Auto M-axis Power-ON Restore.

- (1) Set to the main screen.
- (2) Press F6 key while pressing SET key.

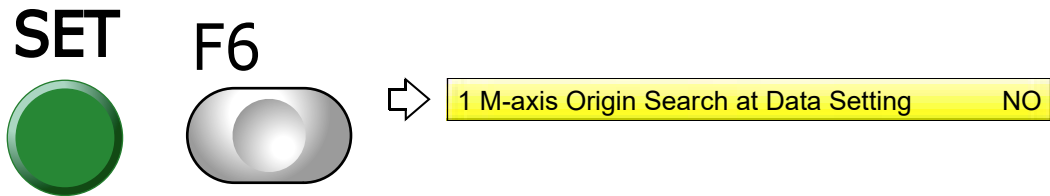

- (3) Press F6 key.

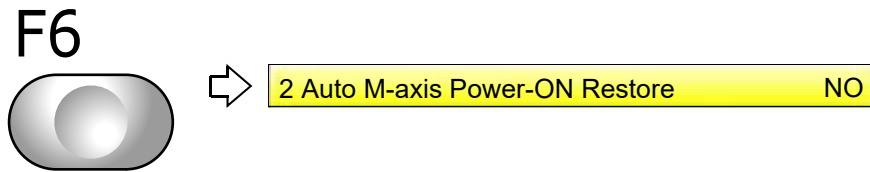

- (4) To set



Chapter 6

Functions concerning embroidery

1. To perform color change, to switch head	102
2. To trim thread.....	104
3. To set the embroidery speed	115
4. To stop the machine.....	118
5. To change the direction and the size of the design.....	120
6. To embroider the same design repeatedly.....	122
7. To adjust finishing of embroidering	126
8. To increase embroidering efficiency	138
9. To edit design.....	141
10. Setting and resetting of password	151
11. Various functions	154

1

2

3

4

5

6

7

8

9

10

11

12

1. To perform color change, to switch head

1-1. To perform color change manually, to change stitch type (Manual Color Change)

To perform embroidery with the value set here, set "Auto Color Change" to "NO".

1-1-1. Explanation on the screen

When CM head is selected



↑
Looper

a, b, c, d, e, f

When FM head is selected



↑
Needle bar No.

1 to last needle

(TCMX-mixed type series)

1-1-2. How to operate

! CAUTION

⊘ When performing this operation, do not put your hands etc. around the needle bar case or the looper. Moving needle bar or looper would injure you.

The following is an example of changing from the looper a to the looper C.

(1) To open screen

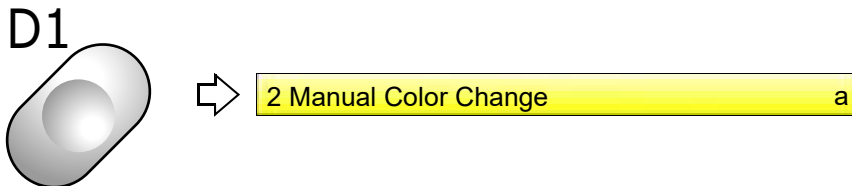

(2) To select the looper and execute color change

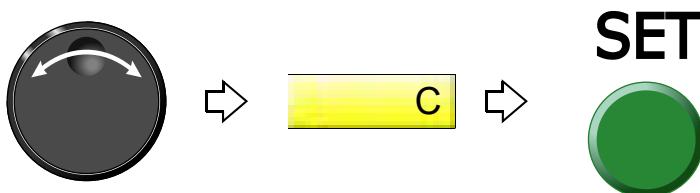

1-2. To switch CM head, FM head manually (Manual Head Selection)

1-2-1. Explanation on the screen



1-2-2. How to operate

! CAUTION

⊘ When performing this operation in the middle of embroidery, do not put your hands etc. near needle or on the machine table. Since needle and nipple move up/down and the frame moves, you could be injured.

The following is an example of switching from FM head to CM head.

(1) Set "Auto Color Change (AC)" to "NO".

(2) To open screen

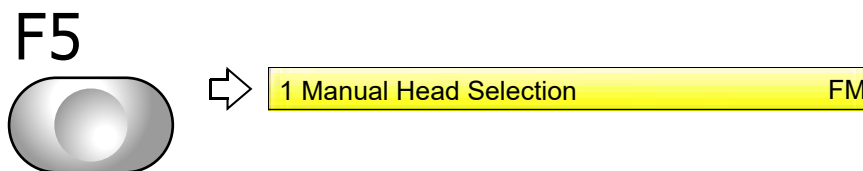

(3) To select CM

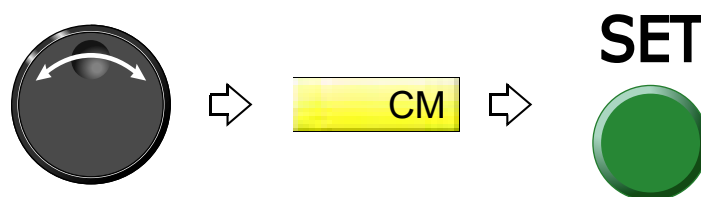

2. To trim thread

2-1. To trim thread manually (Manual Thread Trimming)

Thread trimming is performed at the selected head.

2-1-1. Explanation on the screen



↑
 ○ : To trim upper/under thread (FM head)
 To trim thread (CM head)
 Under thread: To trim under thread only (FM head only)
 By turning the jog dial in the state of "—" displayed, "Under thread" will appear.

2-1-2. How to operate

 **CAUTION**

 When performing this operation, do not put your hands etc. near the needle. Moving up/down of the needle bar could injure you.

The following is an example of executing thread trimming.

(1) To open screen

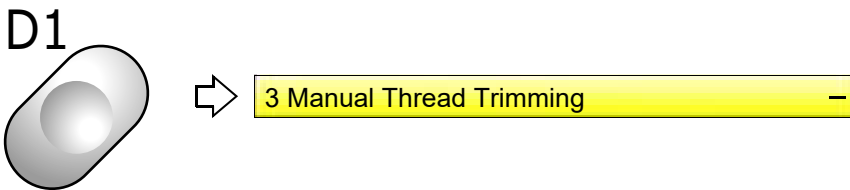

(2) To execute thread trimming

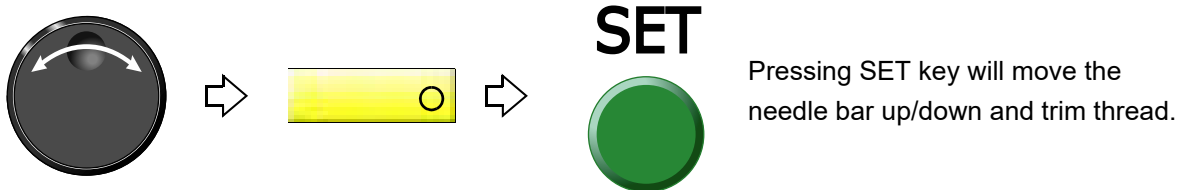

2-2. To trim thread automatically (FM head)

It is the setting to trim thread. This function is applied for TCMX-mixed type series.

2-2-1. Explanation on the screen

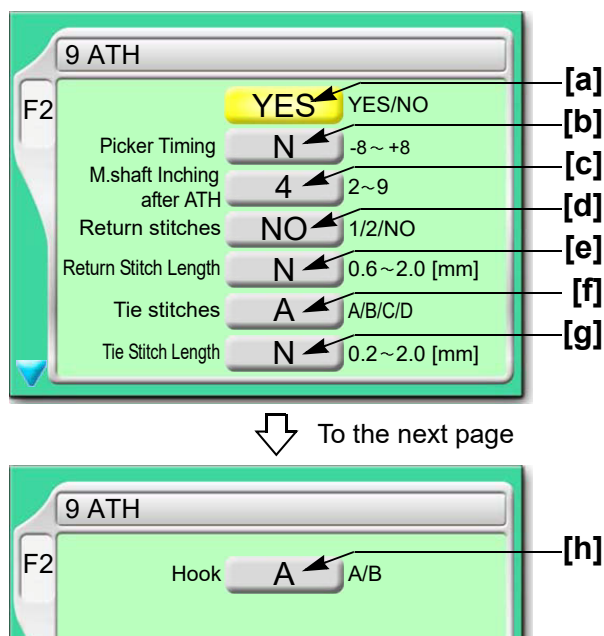

[a] To trim thread automatically

YES: To trim

NO: Not to trim thread

[b] Remaining length of upper thread after thread trimming (1 in the right figure)

-8 ← 0 → +8
Short Long

When upper thread remains on the fabric, select the value of "-".

If the thread does not link at the start of sewing due to short of remaining length of upper thread, select the value of "+".

When "N" is displayed, the value differs in each needle bar.

Regarding the setting of needle bar unit, refer to detailed page.(→p.130)

[c] Number of lowering the needle bar by slow operation at start after thread trimming or after data set

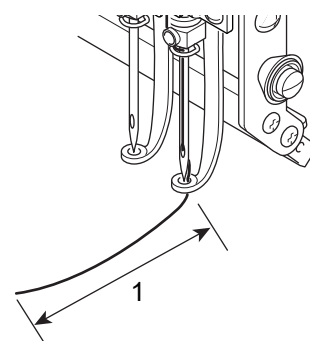

[d] The number of return stitches at start of sewing

The more return stitches are, the less mis-stitching at start decreases.

1: One reciprocation

2: Two reciprocations



[e] Stitch length of [d] described above

When "N" is displayed, the value differs in each needle bar. (→p.130)

[f] Tie stitching at thread trimming

Setting more tie stitches prevent the thread from pulling out.

A: Not to perform tie stitching

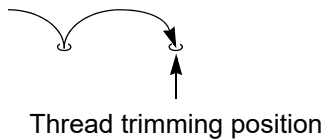

B: To perform tie stitching (once)

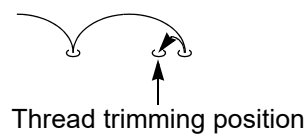

C: To perform tie stitching after lowering the needle twice on the same position at the end of the stitch

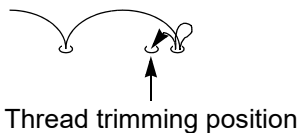

D: To perform tie stitching (twice)

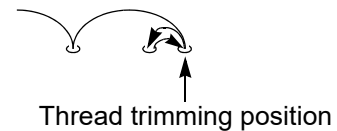

[g] Stitch length of [f] described above

When "N" is displayed, the value differs in each needle bar. (→p.130)

[h] Coming-out amount of hook (thread holder) (2 in the right figure)

Select A.

A: Short

B: Long

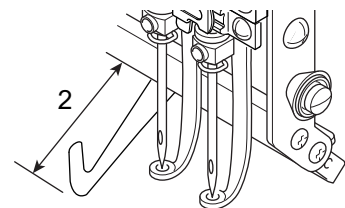

CAUTION

! Select "A" for hook. Wrong selection would cause abnormal noise and/or not to hold the thread normally.

2-2-2. How to operate

The following is an example that the thread is trimmed automatically, the thread trim length is set to "+2" and inching after ATH is set to "3".

(1) To open screen

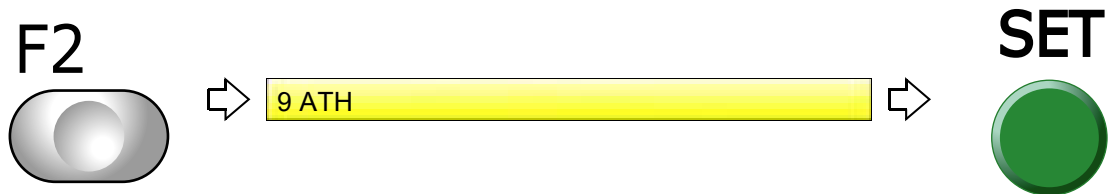

(2) To trim thread automatically

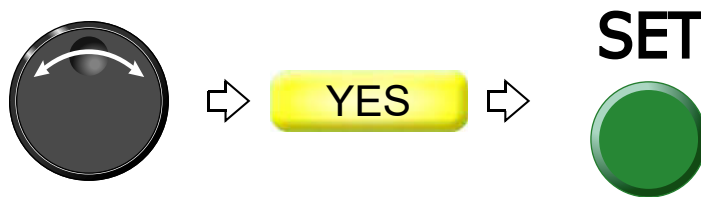

(3) To select thread trim length

When "N" is displayed, changing "N" to a value will set the detecting sensitivity in all needle bars to the same.

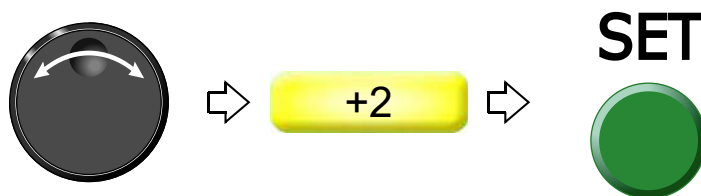

(4) To select number of inching times at start after ATH

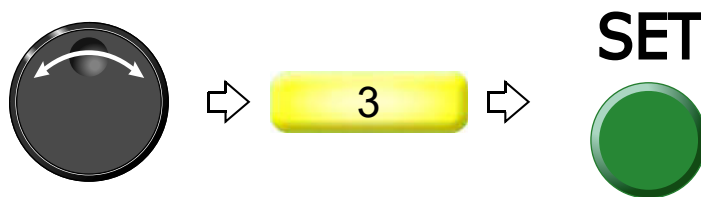

1
2
3
4
5
6
7
8
9
10
11
12

2-3. To change thread breakage detecting sensitivity (FM head)

Use this function in the following cases. This function is applied for TCMX-mixed type series.

- (1) Thread breakage is detected even when thread is not broken.
- (2) Thread breakage detection timing is late.

2-3-1. Explanation on the screen

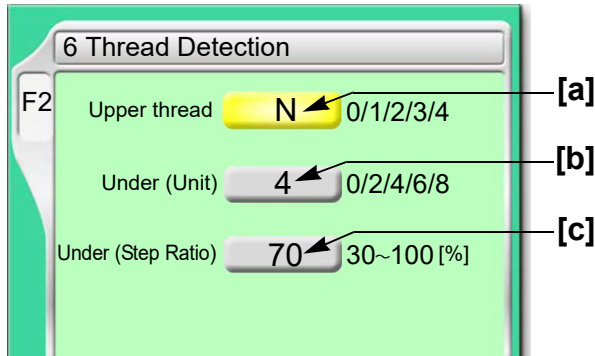

[a] Setting how many consecutive detections of upper thread breakage are regarded as thread breakage

0: Not to stop even if upper thread breaks

When idling the machine, set "Upper" and "Under (Unit)" to "0".

N: To stop if upper thread is broken (the detecting sensitivity differs in each needle bar) (→p.130)

1, 2, 3, 4: To stop if upper thread is broken (Detecting sensitivity is the same in all needle bar)

When selecting "3", the thread breakage will be detected after upper thread breaks three times continuously.

The relationship between the number of detecting times and sensitivity is shown as follows.

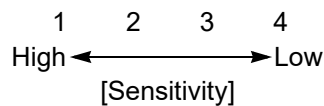

[b] Setting how many consecutive detections of [c] "Under (Step Ratio)" are regarded as thread breakage to stop the machine

0: Not to stop even if under thread is broken

When idling the machine, set "Upper" and "Under (Unit)" to "0".

N: To stop if under thread is broken (the detecting sensitivity differs in each needle bar)(→ p.130)

2, 4, 6, 8: To stop if under thread is broken (Detecting sensitivity is same in all needle bar)

When selecting "4", the thread breakage will be detected after under thread breaks four times continuously.

The relationship between the number of detecting times and sensitivity is shown as follows.

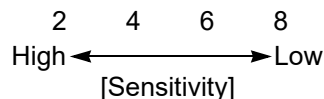

[c] Set sensitivity of [b] "Under thread (Unit)" in the figure above. Change this value according to the type of fabric and thread to use. It enables to prevent mis-detection.

N: To stop if under thread is broken (the detecting sensitivity differs in each needle bar)
 (→p.130)

30 to 100: To stop if under thread is broken (Detecting sensitivity is same in all needle bar)

The relationship between detecting ratio and sensitivity is shown as follows.

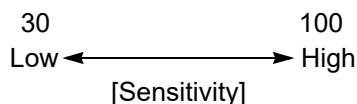

2-3-2. How to operate

The following is an example that the number of upper thread breakage detecting times is set to "2" and the number of under thread breakage detecting times (unit) is set to "6".

(1) To open screen

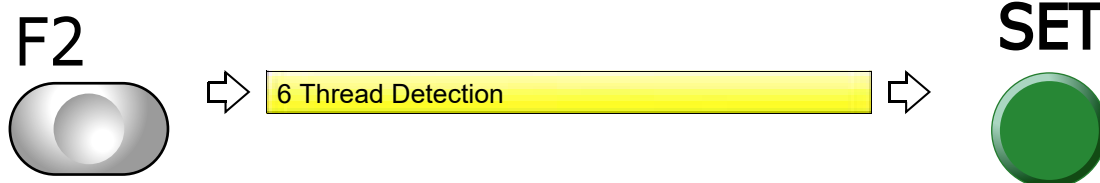

(2) To select the number of upper thread breakage detecting times

When "N" is displayed, changing "N" to a value will set the detecting sensitivity in all needle bars to the same.

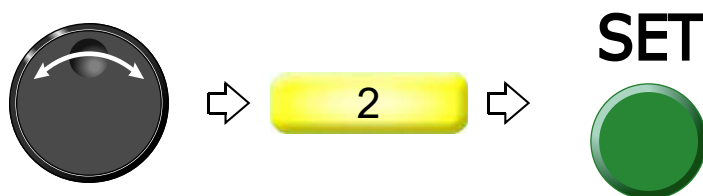

(3) To select number of under thread breakage detecting times (unit)

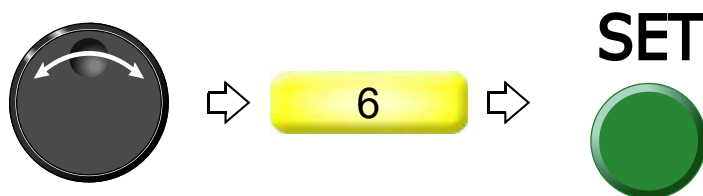

1
2
3
4
5
6
7
8
9
10
11
12

2-4. To change thread breakage detecting sensitivity (CM head)

Use this function in the following cases.

- (1) Thread breakage is detected even when thread is not broken.
- (2) Thread breakage detection timing is late.

2-4-1. Explanation on the screen

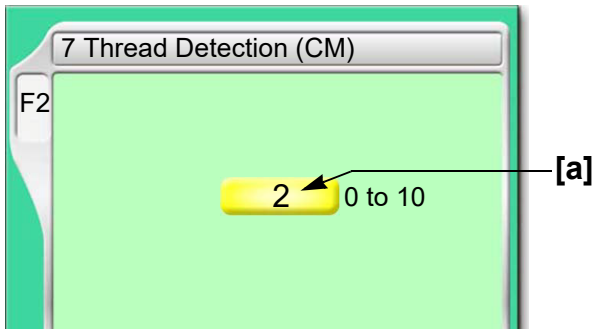

[a] Setting how many consecutive detections of thread breakage are regarded as thread breakage

0: Not to stop even if thread is broken

When idling the machine, set the value to "0".

1 to 10: To stop if thread is broken

When selecting "3", the thread breakage will be detected after thread breaks three times continuously.

The relationship between the number of detecting times and sensitivity is shown as follows.

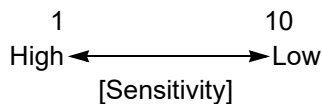

2-4-2. How to operate

The following is an example that the number of thread breakage detection is set to "4".

- (1) To open screen

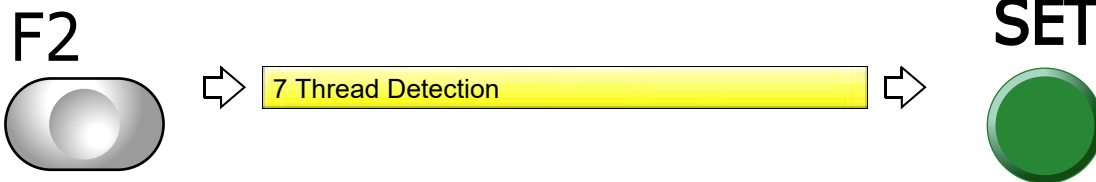

- (2) To select the number of thread breakage detecting times

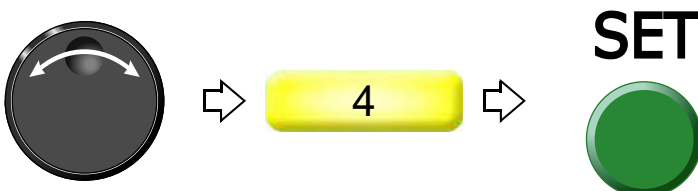

2-5. To trim thread by the number of consecutive jump stitches (Jump Convert)

This function can be used to perform thread trimming in the middle of stitching and moving of the frame to the next stitch by specifying the number of jump code without editing the design.

CM head

Set the frame travel mode. Jump code will cause the machine to perform thread trimming regardless of the setting (NO/1 to 9).

FM head (TCMX-mixed type series)

Set how many consecutive stitches of jump code make the machine perform frame stepping and Frame Movement.

2-5-1. Explanation on the screen

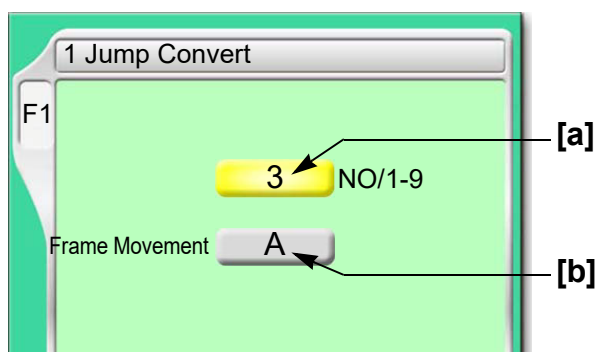

[a] Number of consecutive jump codes (FM head only)

NO: Not effected

1 to 9: Number of consecutive jump codes

[b] How to move frame to next stitch

A: Batch

B: As data

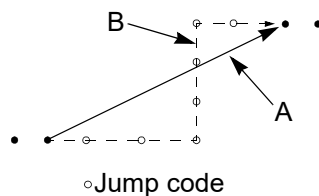

2-5-2. How to operate

The following is an example that the number of consecutive jump code is set to "5".

(1) To open screen

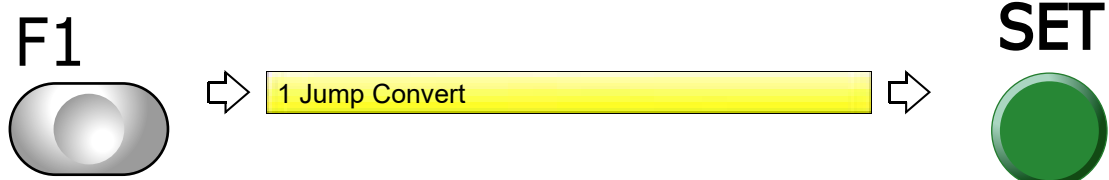

(2) To select number of consecutive jump codes

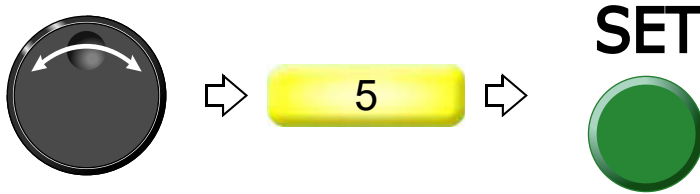

CM head

Existence of even one jump code will cause the machine to perform thread trimming and frame stepping.

FM head (TCMX-mixed type series)

In this example, the machine will perform thread trimming and frame stepping when jump codes continue for 5 stitches.

2-6. To add thread trimming code to the design and trim thread (Data Edit "Insert")

This function always executes automatic thread trimming at the same position by adding thread trimming code to the design. A stitch will be inserted before the selected stitch No. When this operation is performed in the middle of embroidery, data set will be canceled. If the stitch with a length length is inserted, a design will be displaced hereafter.

2-6-1. Explanation on the screen

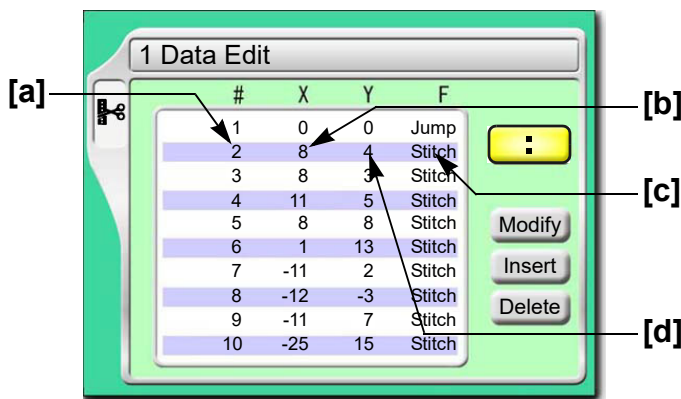

[a] Stitch No.

[b] X data (Data to move the frame in X-axis direction)

When the value is 8, the frame travel amount is 0.8 mm.

[c] Function Code(→p.268)

It is the code to indicate the role of the stitch.

[d] Y data (Data to move the frame in Y-axis direction)

When the value is 4, the frame travel amount is 0.4 mm.

2-6-2. How to operate

 **CAUTION**

 The original design will be overwritten after editing. Back up design data as necessary.

The following is an example that thread trimming code is added to 20th stitch.

(1) To open screen

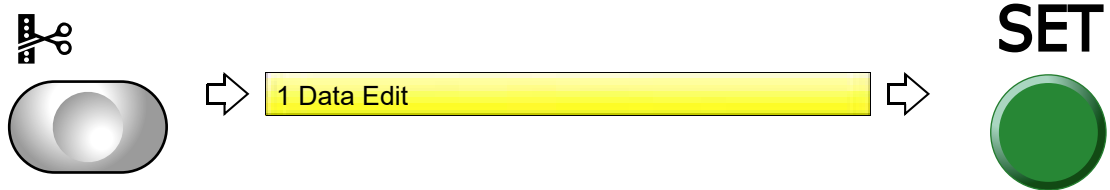

(2) To select a design



(3) To select stitch No. to perform thread trimming

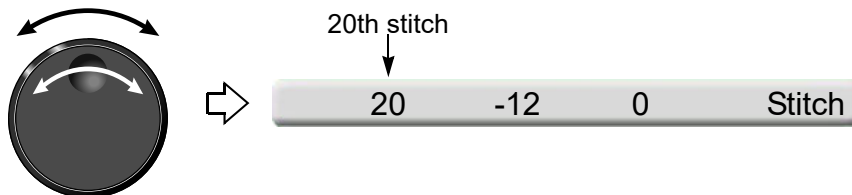

(4) To select "Insert" and decide

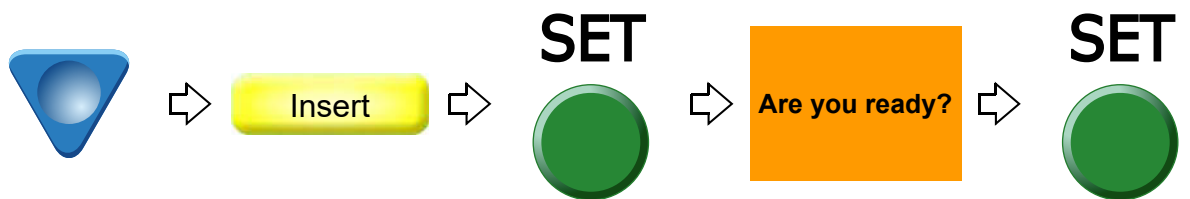

(5) To select "Modify" to move the cursor

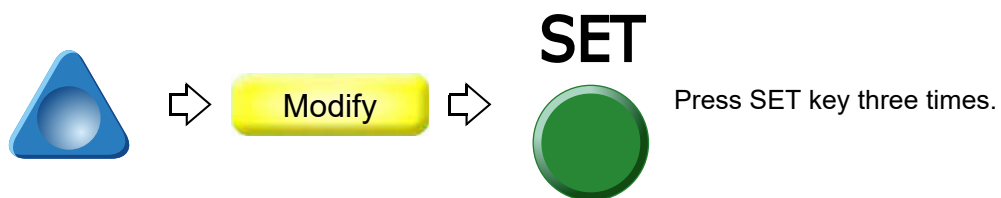

(6) To select "ATH"



(7) To decide

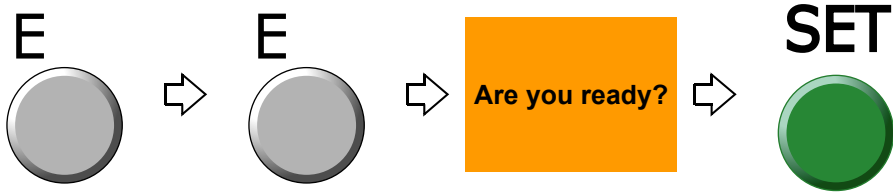

3. To set the embroidery speed

3-1. To limit embroidery speed by stitch length (Minimum RPM) (FM head)

This function is applied for TCMX-mixed type series.

3-1-1. Explanation on the screen

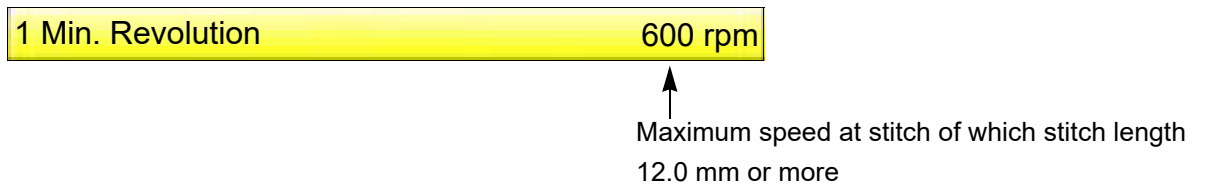

3-1-2. How to operate

The following is an example that Low Speed R.P.M. is set to "550 rpm".

(1) To open screen

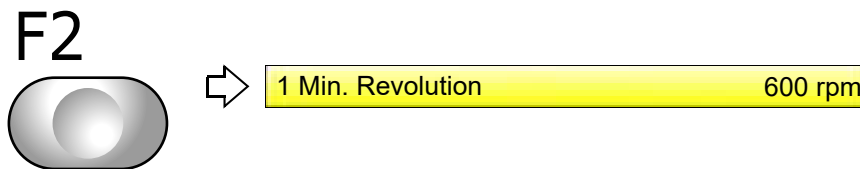

(2) To select Low speed R.P.M.

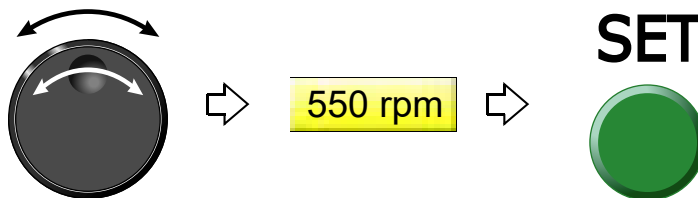

1
2
3
4
5
6
7
8
9
10
11
12

3-2. To decide upper limit value of the maximum speed (Max. Revolution Limit) (FM head)

This function is applied for TCMX-mixed type series.

Set the maximum speed of the section where the embroidery speed is restricted. The area where speed was restricted in the design is surrounded by the following function code.

Function Name	Function Code
Low Speed Start Stitch	Low_S
Low Speed End Stitch	Low_E

3-2-1. Explanation on the screen

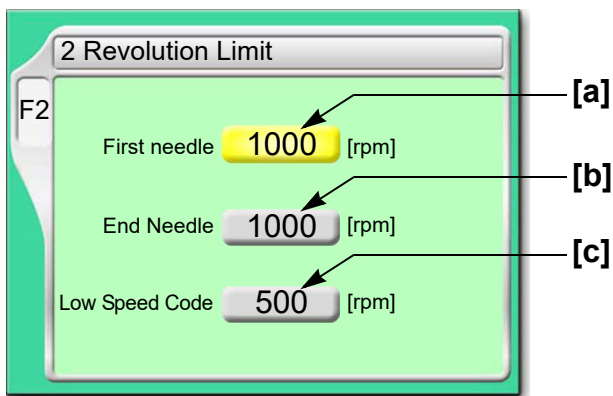

[a] Maximum speed of the first needle

[b] Maximum speed of the last needle

[c] Maximum speed of section between function codes Low_S to Low_E

3-2-2. How to operate

The following is an example that the maximum speed of the 1st needle is set to "700".

(1) To open screen

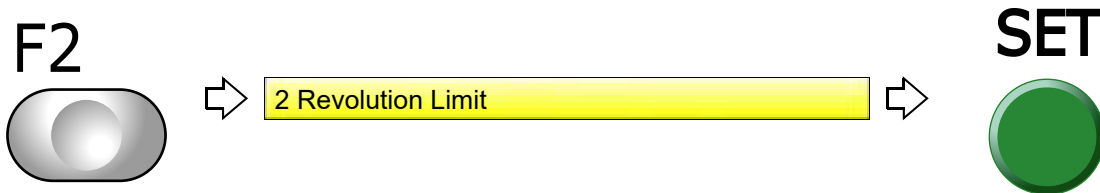

(2) To select maximum speed



3-3. To decide upper limit value of the maximum speed (Max. Revolution Limit)

3-3-1. Explanation on the screen

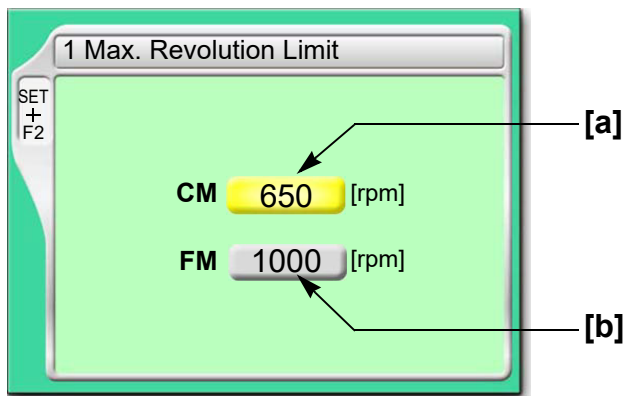

[a] Upper limit value of the maximum speed of CM head

[b] Upper limit value of the maximum speed of FM head
(TCMX-mixed type series)

3-3-2. How to operate

The following is an example that CM head max. revolution limit is set to "750".

(1) Set to main screen.

(2) To press F2 key while pressing SET, and press SET further

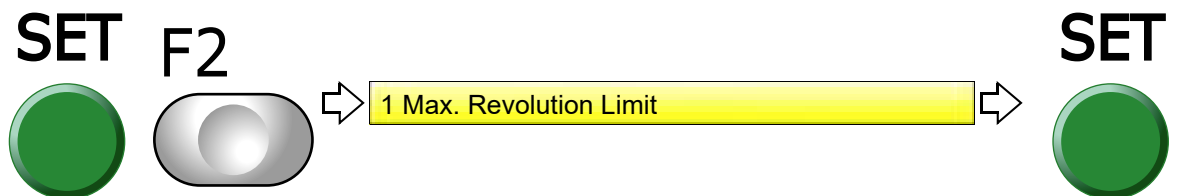

(3) To cancel the password

Regarding canceling method, refer to the detail page.(→p.153)

(4) To select limit of max revolution



4. To stop the machine

4-1. To stop the machine automatically when reaching the set value (Preset Halt)

4-1-1. Explanation on the screen

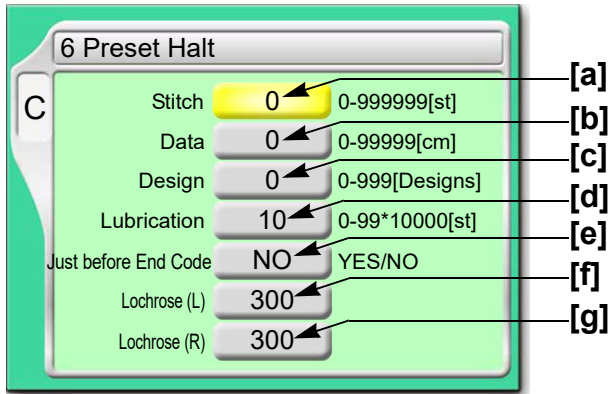

[a] The machine will stop when counting reaches the number of the set stitches. (Display of 1D2)

[b] The machine will stop when embroidery stitch length reaches the set length (display of 1D2).

[c] The machine will stop when the number of designs reaches the set numbers. (Display of 1D2).

[d] The machine will stop when counting reaches the number of set stitches. (Display of OIL)

When automatic lubrication system is set to "YES", it will not be displayed.

[e] The machine will stop short of the end code by one stitch (display of 1D2).

YES: To stop

Since embroidery is not finished, it is possible to perform frame back.

NO: Not to stop

[f] Quantity of beads attached to Lochrose embroidery device (option) at left

When the equipped beads run out, the machine stops (display of 1D5).

To disable this function, select "NO". This setting will be displayed when "Lochrose embroidery device" is set as "L" or "L + R". (→p.207)

[g] Quantity of beads attached to Lochrose embroidery device (option) at right

The contents are same as above.

4-1-2. How to operate

The following is an example that the halt by the number of stitch is set to "15000".

(1) To open screen

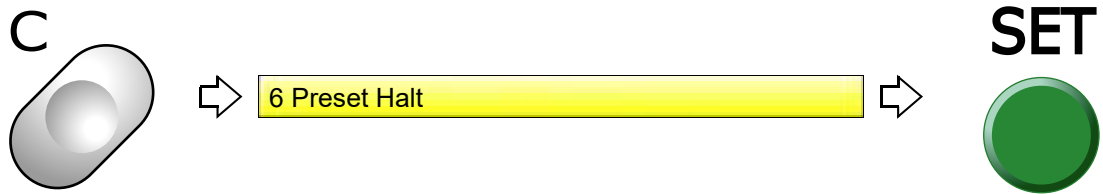

(2) To select value of halt by number of stitch



4-2. To stop the machine with the needle bar stuck in the material (Stop at Lower D.Point)

This setting stops the machine with the needle stuck in the material at the end of embroidery.

4-2-1. Explanation on the screen

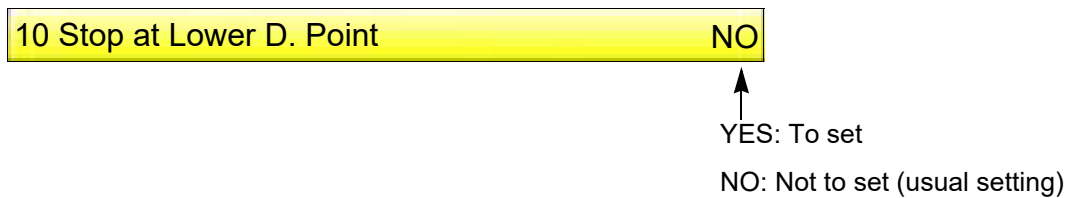

4-2-2. How to operate

The following is an example that Stop at Lower D. Point is set.

(1) To open screen

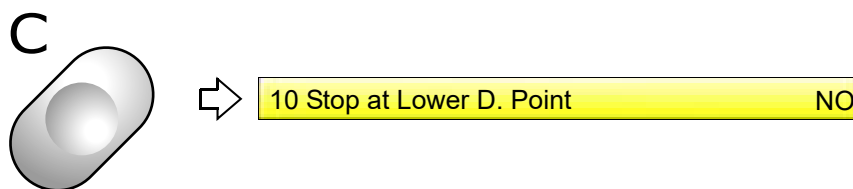

(2) To set Stop at Lower D. Point



5. To change the direction and the size of the design

5-1. To perform enlargement, rotation, reversion (Data Conversion)

Set this function after data set. Setting contents here will be added in a design. So, when you embroider this design next time, setting again will be unnecessary.

5-1-1. Explanation on the screen

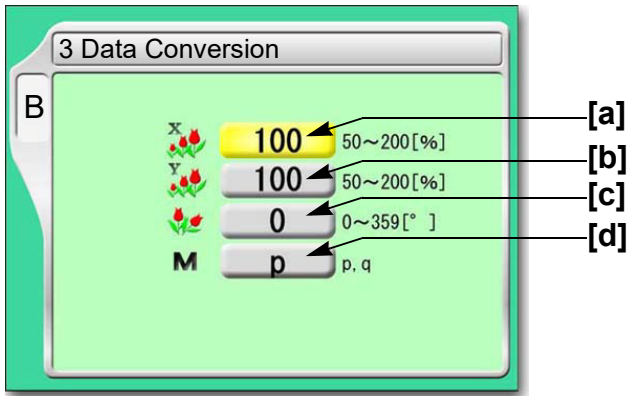

[a] Horizontal (X) scale ratio (%)

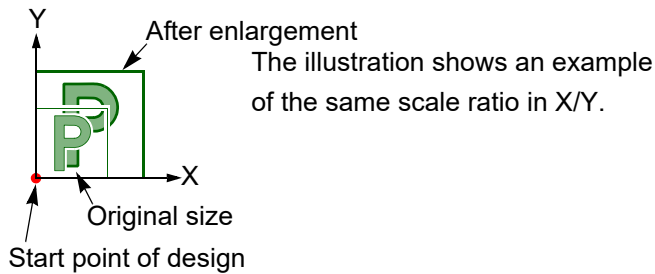

[b] Vertical (Y) scale ratio (%)

[c] Rotating angle (°)

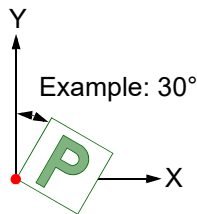

[d] Reverse

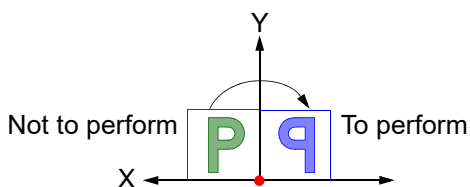

5-1-2. How to operate

The following is an example that horizontal scale ratio and vertical scale ratio are set to "120".

(1) To open screen

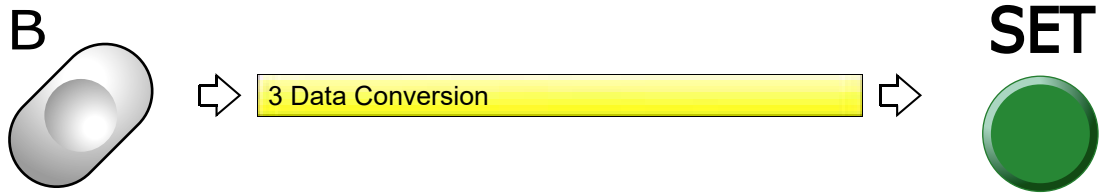

(2) To select horizontal scale ratio



(3) To select vertical scale ratio



1
2
3
4
5
6
7
8
9
10
11
12

6. To embroider the same design repeatedly

6-1. To repeat to horizontal and vertical direction (Repeat)

Set this function after data set. Setting contents here will be added in a design. So, when you embroider this design next time, setting again will be unnecessary.

6-1-1. Explanation on the screen

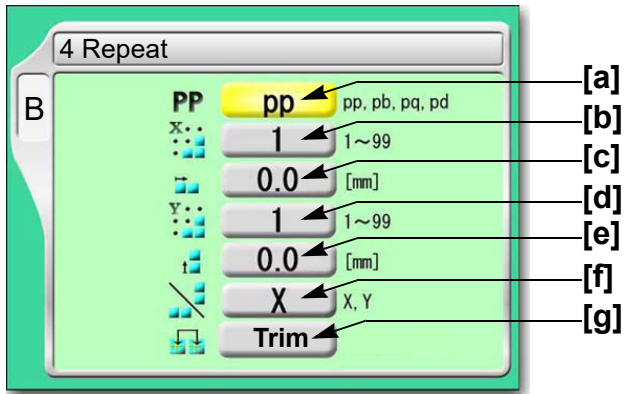

[a] Repeat method

The illustration below is an example that the priority embroidery direction is vertical.

[In case of pp]

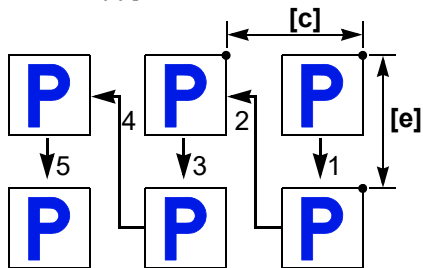

[In case of pq]

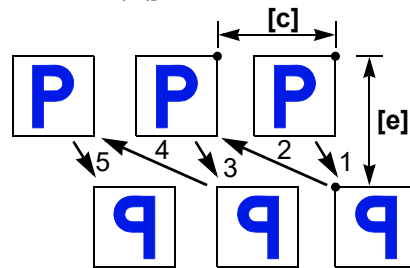

[In case of pb]

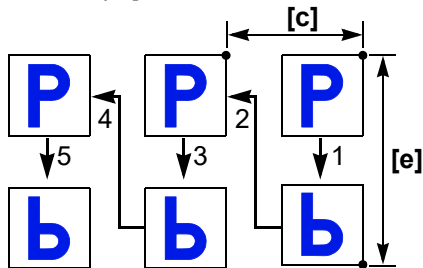

[In case of pd]

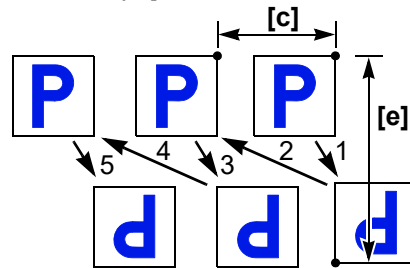

[b] Number of repeats in horizontal

[c] Interval in horizontal (mm)

Repeat direction will be decided by code.
 Selecting "-" will perform embroidering at left repeatedly.

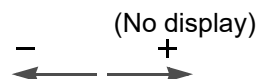

[d] Number of repeats in vertical

[e] Interval in vertical (mm)

Repeat direction will be decided by code. Selecting "-" will perform embroidering at front.

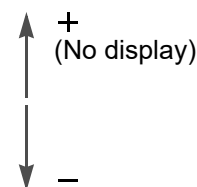

[f] Priority embroidering direction (horizontal/vertical)

It is the setting which direction is given priority to embroider, horizontal(X) or vertical(Y).

[g] To embroider the next design after thread trimming

It is displayed only and cannot be changed.

6-1-2. How to operate

! CAUTION

When performing this operation, do not put your hands, etc. on the table. Moving the frame could injure you.

The following is an example that repeat pattern "pb", the number of repeats in horizontal "3", interval in horizontal "-60", the number of repeats in vertical "2", interval in vertical "-50", priority direction "X" are set.

(1) To open screen

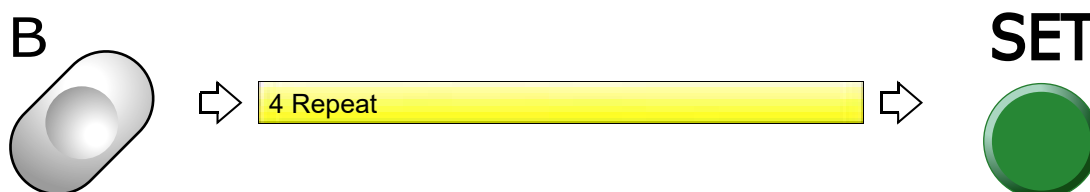

(2) To select repeat pattern

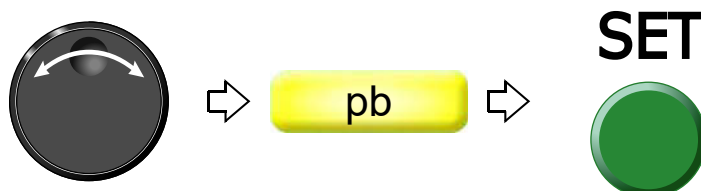

(3) To select number of repeats in horizontal

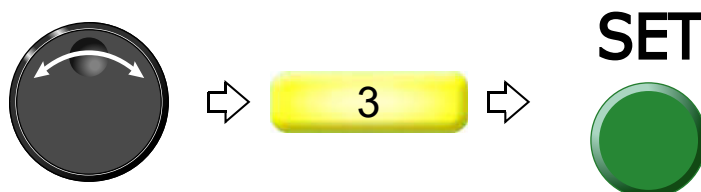

(4) To select interval in horizontal (mm)

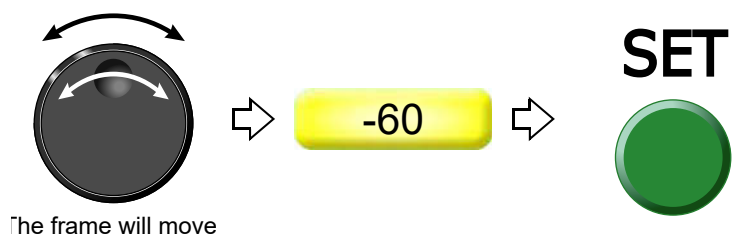

(5) To select number of repeats in vertical



(6) To select interval in vertical (mm)

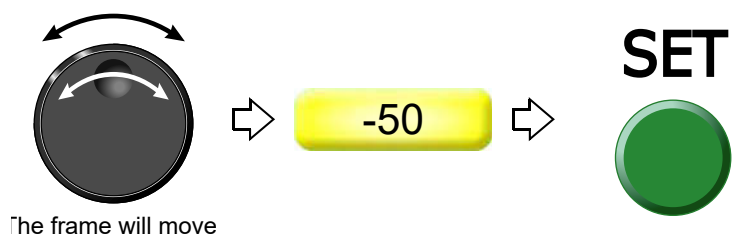

(7) To select priority embroidering direction

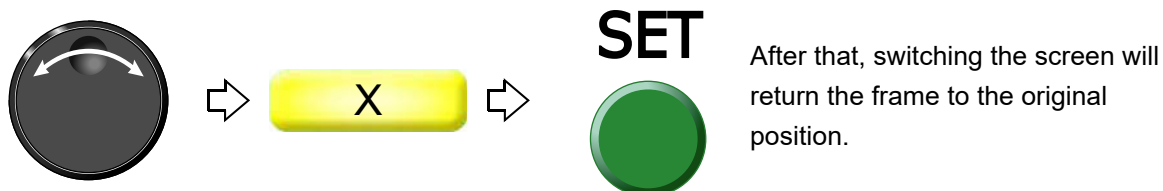

To cancel the setting of repeat, set "the number of repeats in horizontal" and "the number of repeats in vertical" to "1".

6-2. To repeat at the same place (A.S. after Auto Data Set)

This setting makes the machine start automatically after finishing embroidery and embroider the same design repeatedly.

This function is effective only when "Auto Start (AS)" is set to "YES".(→p.57)

6-2-1. Explanation on the screen

6 Automatic Start after Automatic Data Set NO

↑
YES: To set
NO: Not to set (usual setting)

6-2-2. How to operate



The following is an example that Automatic Start after Automatic Data Set is set.

(1) To open screen

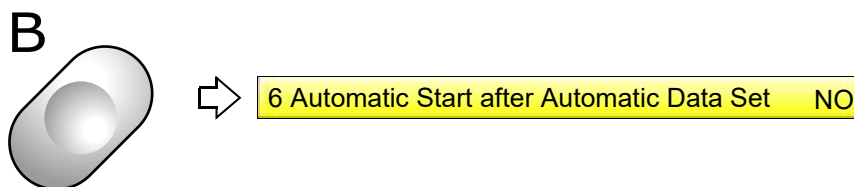

(2) To set automatic start after automatic data set



7. To adjust finishing of embroidering

7-1. To adjust driving error of the frame (Backlash) (FM head)

This function corrects error of finished stitching generated by Backlash. Backlash means the play generated by the shock in the parts at the drive system or around the frame when return stitches are executed.

This function is applied for TCMX-mixed type series.

7-1-1. Explanation on the screen

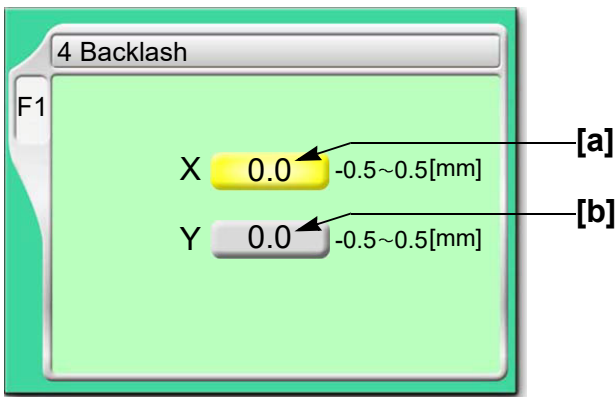

[a] Correcting value in horizontal

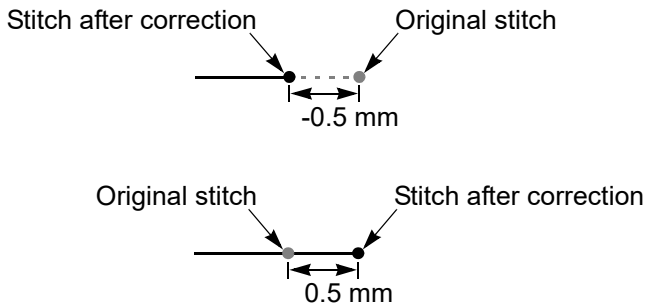

[b] Correcting value in vertical

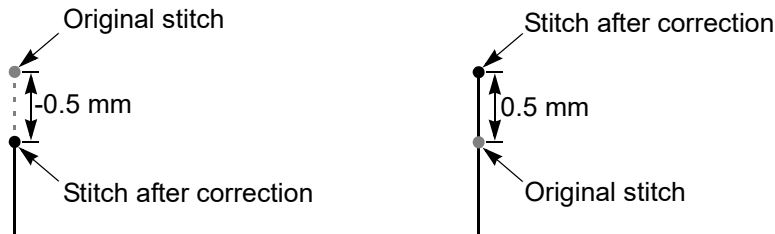

[Example of combination of X/Y correcting value]

The left illustration shows an example that the values are X:0.5 and Y:0.5.

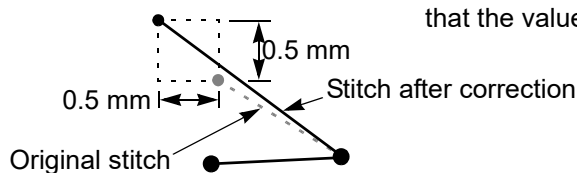

7-1-2. How to operate

The following is an example that correcting value of horizontal direction is set to "0.3".

(1) To open screen

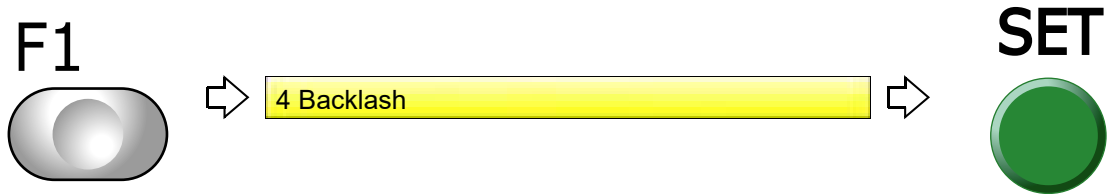

(2) To select correcting value in horizontal

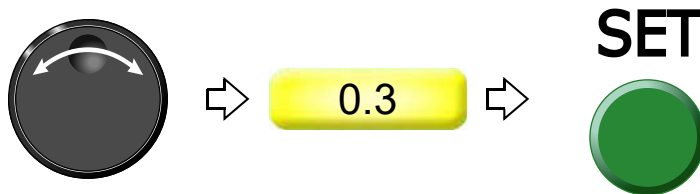

7-2. To adjust stitch length of Satin Stitch (Satin Stitch) (FM head)

This function is applied for TCMX-mixed type series.

7-2-1. Explanation on the screen

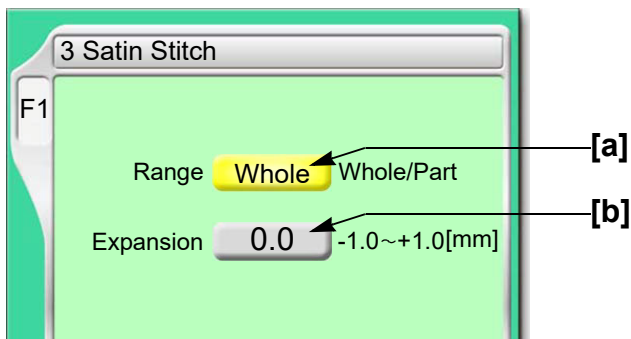

[a] Applicable range

Whole: All satin stitches in the design are targets.

Part:

Satin stitches of the section surrounded by satin stitch codes (Satin_S to Satin_E) are targets. It is necessary to add the satin stitch code if it is not in the design.

[b] Adding amount

1/2 of the value will be added to both sides of stitch length.

Example of the value in +0.4 mm

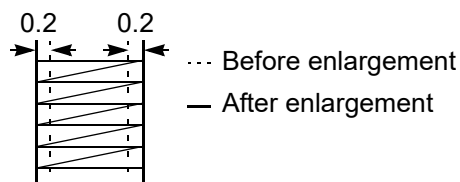

7-2-2. How to operate

The following is an example that applicable range is set to "part" and expansion amount is set to "+0.4".

(1) To open screen

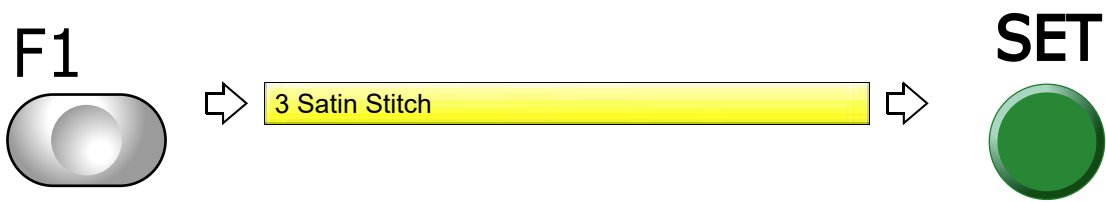

(2) To select applicable range

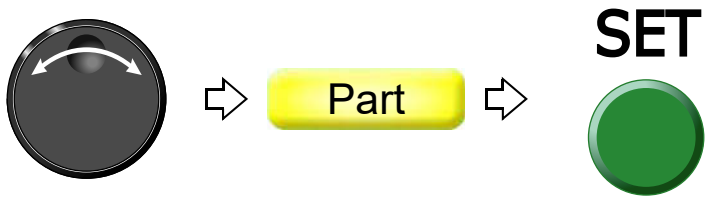

(3) To select adding amount

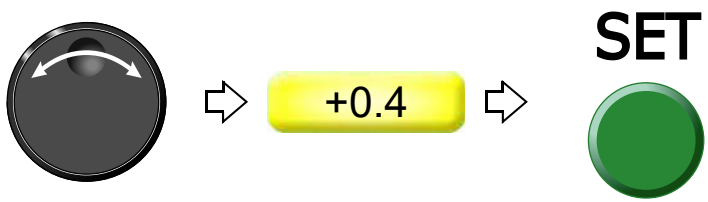

7-3. To divide a long stitch (Auto Jump) (FM head)

Divide the frame movement by jump automatically when a stitch length exceeds a setting value. This function reduces the load generated at the frame drive due to heavy weight of the embroidered material. However, dividing by jump will reduce embroidering efficiency. This function is applied for TCMX-mixed type series.

7-3-1. Explanation on the screen

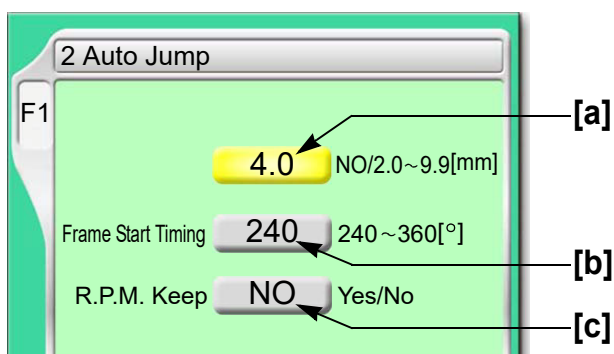

[a] Setting for auto jump

NO: Not to perform

2.0 to 9.9:

The machine will jump automatically when a stitch exceeding a set value is given. When a value is 4.0, the machine will jump automatically if stitches of 4.1 mm and more are given. When the setting of frame type is set to "Auto Clamp Frame", setting range is 2.0 to 5.0 mm.

[b] Timing to start moving the frame(→p.133)

[c] R.P.M. at auto jump

YES: To keep (remaining in high speed)

NO: Not to keep (speed reduction according to a stitch length)

7-3-2. How to operate

The following is an example that stitch length to jump automatically is set to "6.0".

(1) To open screen

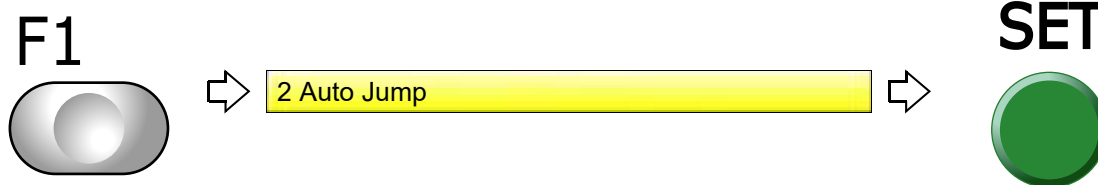

(2) To select stitch length to perform automatic jump

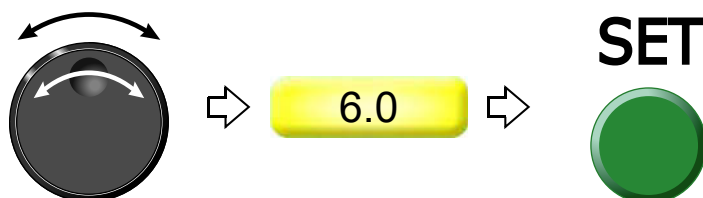

7-4. To change embroidering condition in every needle bar (Setting in Units of Needle Bar) (FM head)

This function is applied for TCMX-mixed type series.

7-4-1. Explanation on the screen

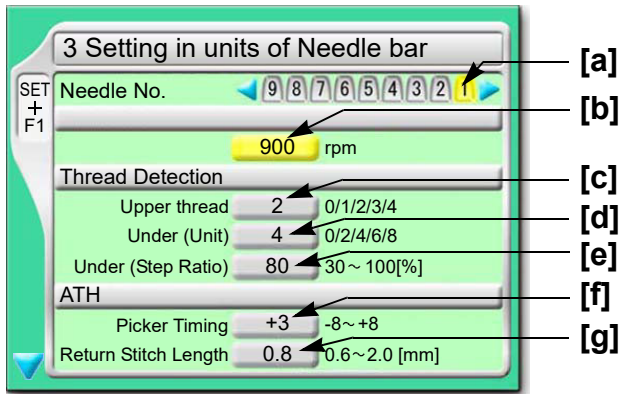

↓ To the next page

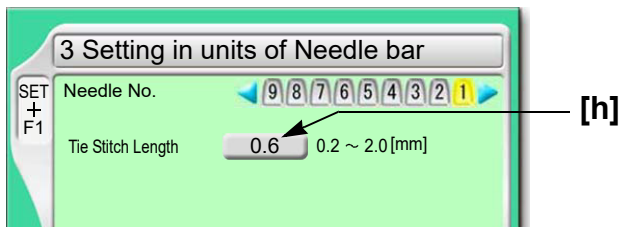

[a] Needle bar No. applied to sewing condition
Perform the following setting for this needle bar.

[b] Maximum speed

[c] Number of upper thread breakage detecting times

Setting how many consecutive detections of upper thread breakage are regarded as thread breakage

0: Not to stop even if upper thread breaks

When idling the machine, set "Upper" and "Under (Unit)" to "0".

1, 2, 3, 4: To stop if upper thread is broken

When selecting "3", the thread breakage will be detected after upper thread breaks three times continuously.

The relationship between the number of detecting times and sensitivity is shown as follows.

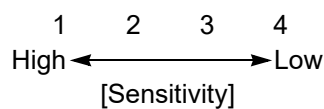

[d] Number of under thread breakage detecting times

Setting how many consecutive times of detection of "under thread (ratio)" of [e] are regarded as thread breakage to stop the machine

0: Not to stop even if under thread is broken

When idling the machine, set "Upper" and "Under (Unit)" to "0".

2, 4, 6, 8: To stop if under thread is broken

When selecting "4", the thread breakage will be detected after under thread breaks four times continuously.

The relationship between the number of detecting times and sensitivity is shown as follows.

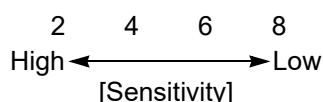

[e] Sensitivity of [d] described above

Set sensitivity of [d]. Change this value according to the type of fabric and thread to use. It enables to prevent mis-detection.

30 to 100: To stop if under thread is broken

The relationship between detecting ratio and sensitivity is shown as follows.

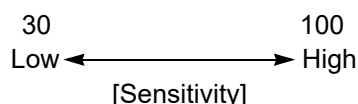

[f] Remaining length of upper thread

Length of remaining upper thread at thread trimming (1 in the right figure)

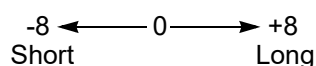

When upper thread remains on the fabric, select the value of "-".

If the thread does not link at the start of sewing due to short of remaining length of upper thread, select the value of "+".

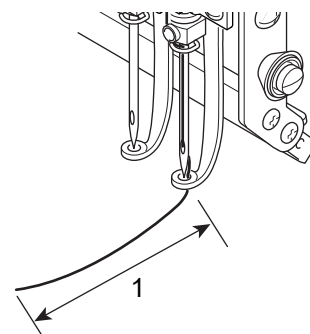

[g] Stitch length of return stitch after start of sewing

[h] Tie stitch length at thread trimming

7-4-2. How to operate

The following is an example that the maximum speed of the 3rd needle is set to "950" and the sensitivity of upper thread breakage detection to "3".

(1) Set to main screen.

(2) To press F1 key while pressing SET

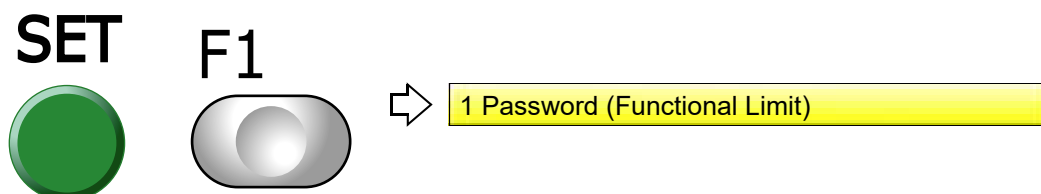

(3) To press F1 key

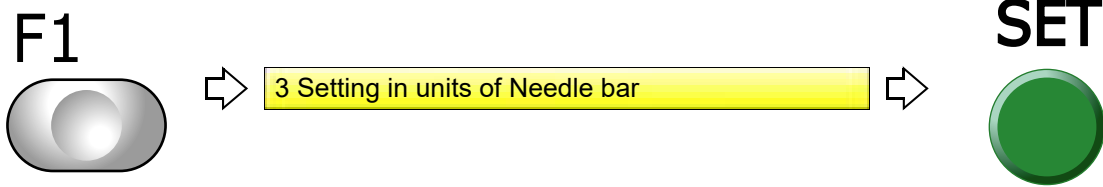

(4) To select the needle bar No.

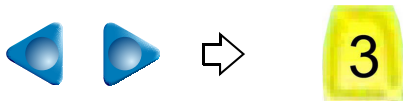

(5) To select maximum speed



(6) To select the number of upper thread breakage detecting times

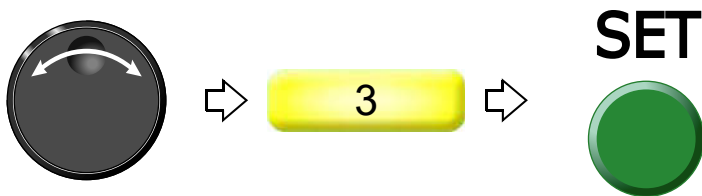

7-5. To delete tiny stitch (Cleanup)

This function removes tiny stitch that causes thread breakage and it is added to the next stitch. This function has an effect to decrease thread breakages.

7-5-1. Explanation on the screen

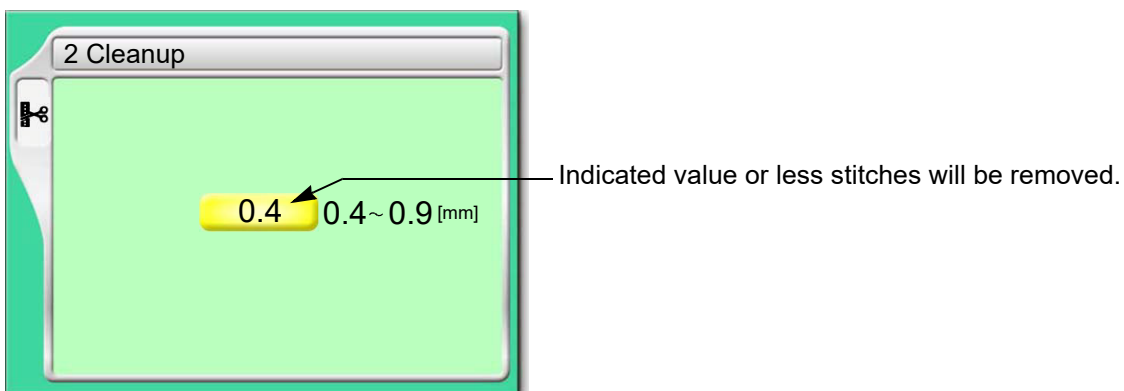

7-5-2. How to operate

! CAUTION

! The original design will be overwritten after removing minute stitches. Back up design data according to need.

The following is an example that the stitch length to remove is set to "0.5".

(1) To open screen

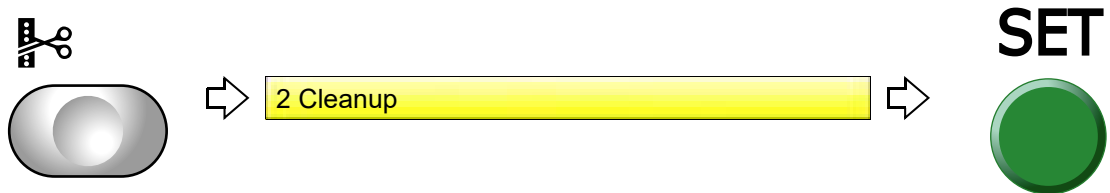

(2) To select a design



(3) To select stitch length to remove, and execute

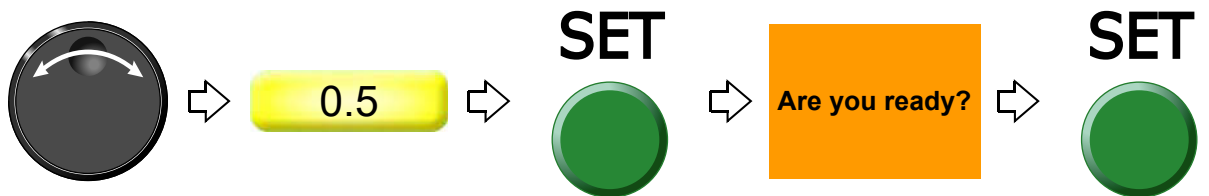

7-6. To change thread tension (Frame Start Timing)

7-6-1. Explanation on the screen

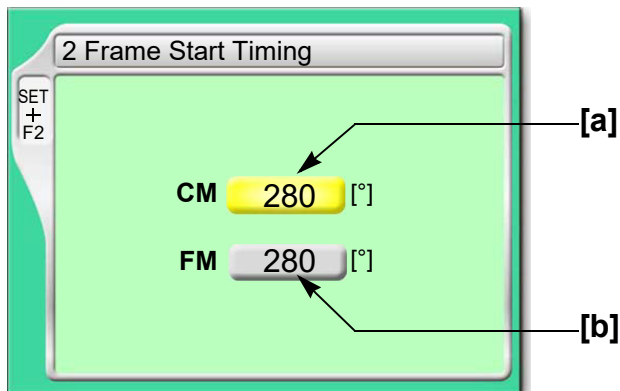

[a] Frame Start Timing of CM head

[b] Frame Start Timing of FM head
(TCMX-mixed type series)

7-6-2. How to operate

⚠ CAUTION

❗ To change this value, consult the distributor. Some operating condition could cause occurrence of fault in thread trimming and affect sewing.

The following is an example that Frame Start Timing of CM head is set to "270".

(1) Set to main screen.

(2) Press F2 key while pressing SET key.

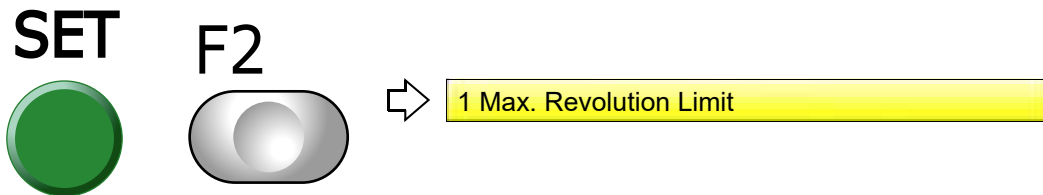

(3) Press F2 key.

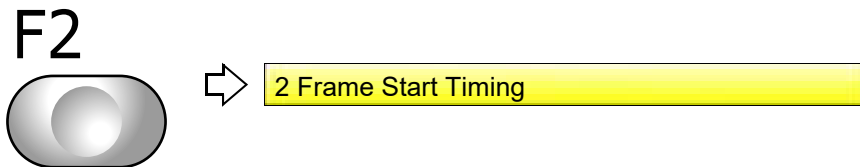

(4) To select Frame Start Timing



7-7. To make a remaining upper thread inconspicuous (Upper Thread Lock Timing) (FM head)

This function is applied for TCMX-mixed type series.

7-7-1. Explanation on the screen

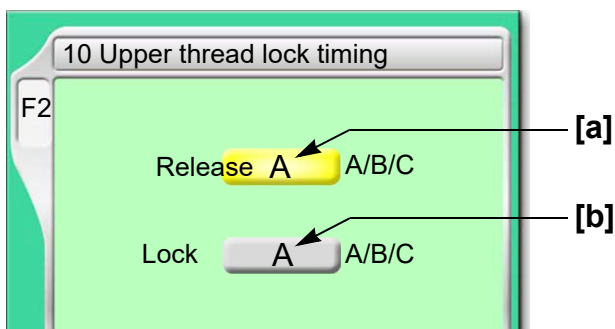

[a] Timing to open upper thread lock

Perform adjustment when the edge of upper thread remains on the fabric after thread trimming. When the edge of upper thread is still highly visible at A, set to B or C.

- A ↓ The edge of upper thread is easy to remain.
- B ↓
- C ↓ The edge of upper thread is hard to remain.

[b] Timing to close upper thread lock

Perform adjustment when the edge of upper thread remains on the fabric after thread trimming. When the edge of upper thread is still highly visible, set to B or C.

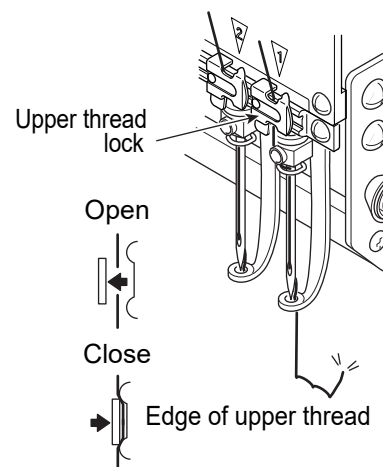

7-7-2. How to operate

The following is an example that remaining length of upper thread is set to "B" after start sewing.

(1) To open screen

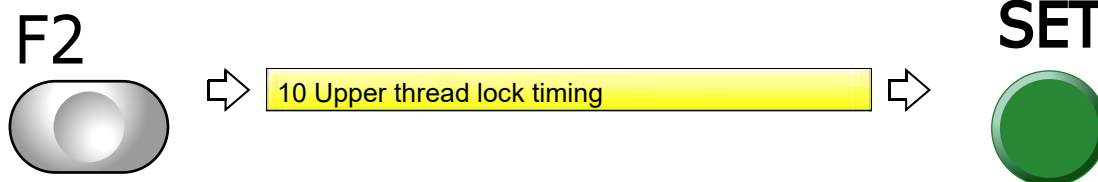

(2) To select remaining length of upper thread after start of sewing

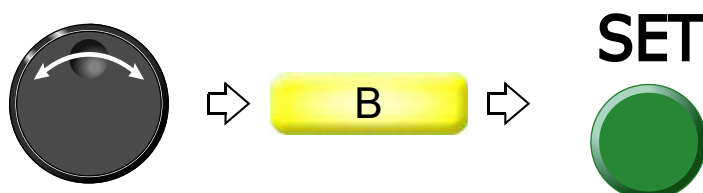

7-8. To adjust stitching length according to a stitch length (Frame Drive Adjustment)

7-8-1. Explanation on the screen

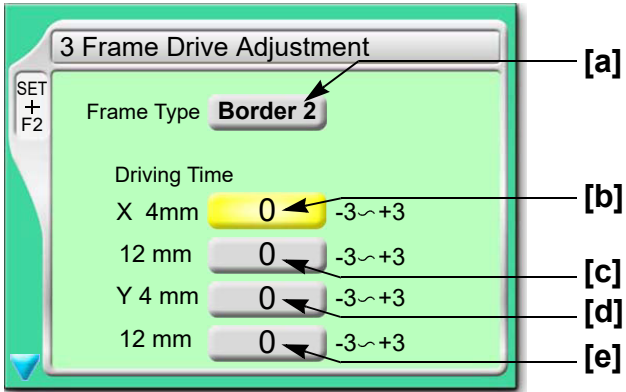

↴ To the next page

Only when selecting "Border 2"

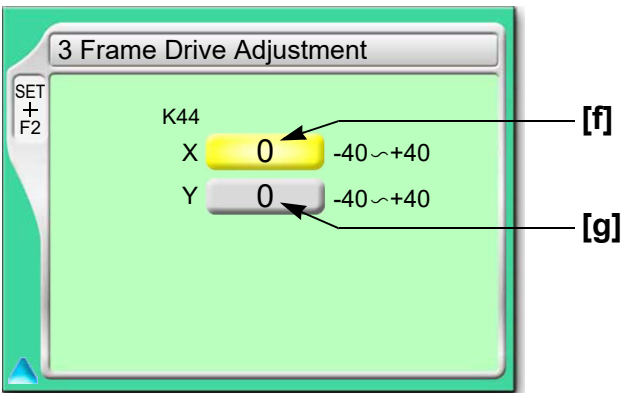

[a] "Frame Type" selected currently(→p.168)

[b] To adjust stitch in horizontal direction of around 4 mm finely

Stitch length tends to be increased in [-] value and decreased in [+] value in general due to characteristic of the machine. However, this aptitude may not be applicable depending on setting condition of other items and/or machine condition.

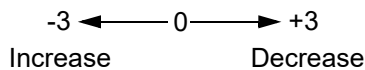

[c] To adjust stitch in horizontal direction of around 12 mm finely

[d] To adjust stitch in vertical direction of around 4 mm finely

[e] To adjust stitch in vertical direction of around 12 mm finely

[f] Whole stitch length of X-axis is adjusted finely regardless of the stitch length.

Stitch length tends to be increased in [-] value and decreased in [+] value in general due to characteristic of the machine. However, this aptitude may not be applicable depending on setting condition of other items and/or machine condition.

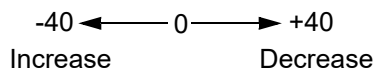

[g] Whole stitch length of Y-axis is adjusted finely regardless of the stitch length.

7-8-2. How to operate

The following is an example that the stitch in horizontal direction of around 4 mm is set to "+1".

- (1) Set to main screen.
- (2) Press F2 key while pressing SET key.

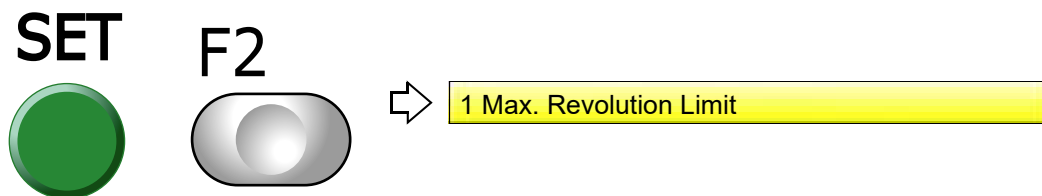

- (3) Press F2 key.

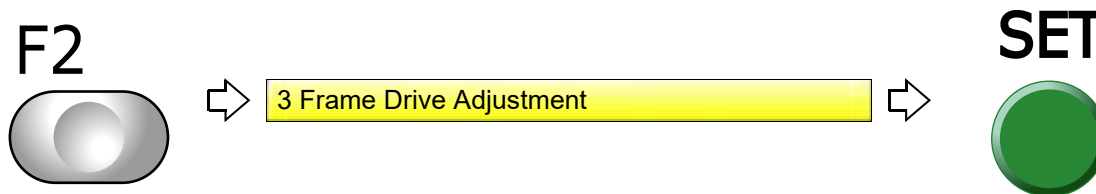

- (4) To select stitch in horizontal direction of around 4 mm

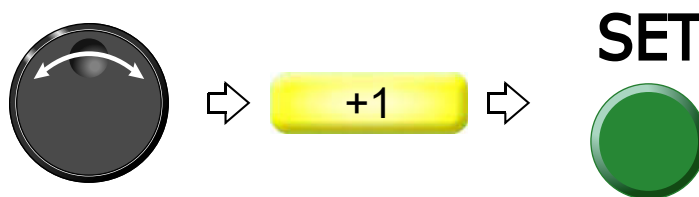

1
2
3
4
5
6
7
8
9
10
11
12

8. To increase embroidering efficiency

8-1. To change the number of lowering needle bar at slow operation (Main Shaft Inching) (FM head)

This function targets slow operation when the machine stops in the middle of embroidery and then the machine restarts. Regarding the number of lowering the needle bar by slow operation at start after thread trimming or after data set, refer to the detail page.(→p.105)

This function is applied for TCMX-mixed type series.

8-1-1. Explanation on the screen

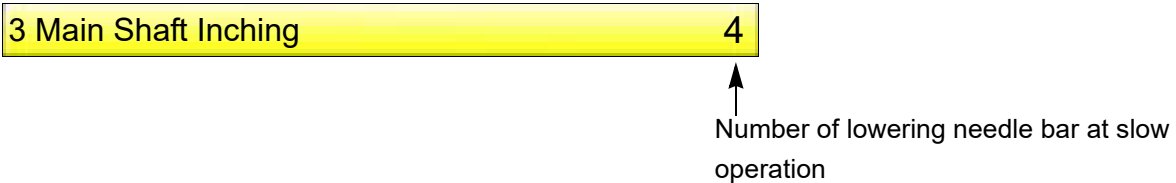

8-1-2. How to operate

The following is an example that the number of Start Inching is set to "3".

(1) To open screen

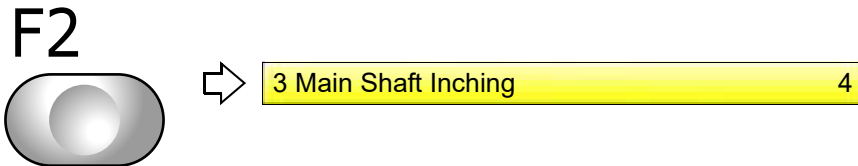

(2) To select number of lowering needle bar at slow operation

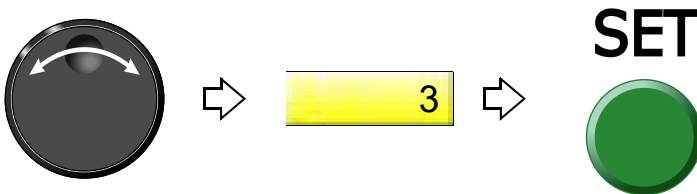

8-2. To collect up frame moving amount of consecutive jump stitches in a batch to feed the frame all at once (Jump code combination) (FM head)

This function reduces the number of stitches by combining frame moving amount of consecutive jump stitches (up to 5 stitches) and by feeding the frame all at once.

This function is applied for TCMX-mixed type series.

8-2-1. Explanation on the screen

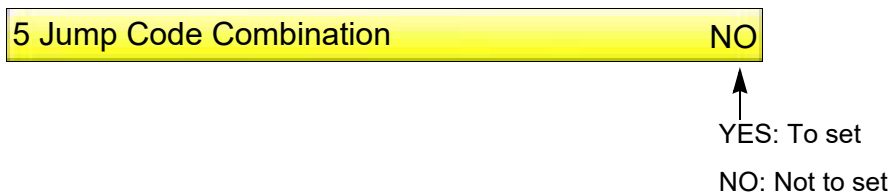

8-2-2. How to operate

The following is an example that Jump Code Combination is set.

(1) To open screen

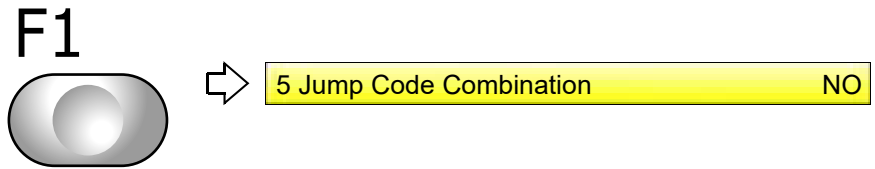

(2) To set Jump Code Combination

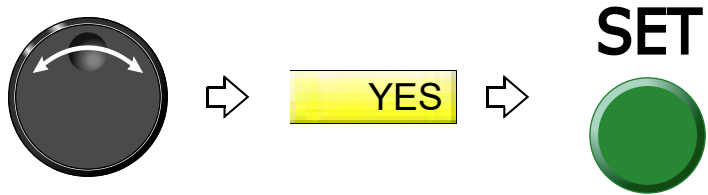

8-3. To change moving speed of the needle bar case (Color change speed) (FM head)

This function is applied for TCMX-mixed type series.

8-3-1. Explanation on the screen

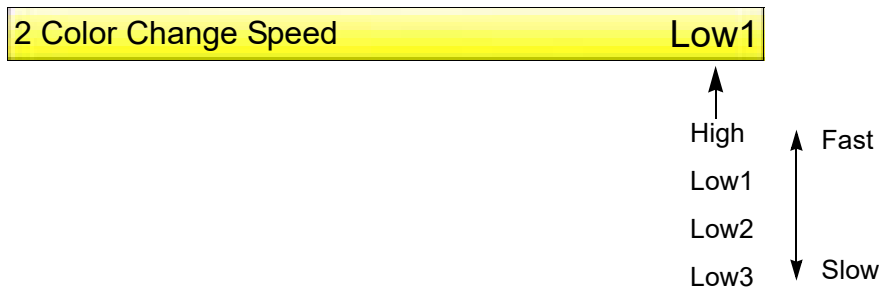

8-3-2. How to operate

The following is an example that Color Change Speed is set to "High".

(1) Press the F5 key within 10 seconds after turning ON the power, and keep on pressing the key. When the window of "F5+PW" starts up, release it.

(2) To select color change speed

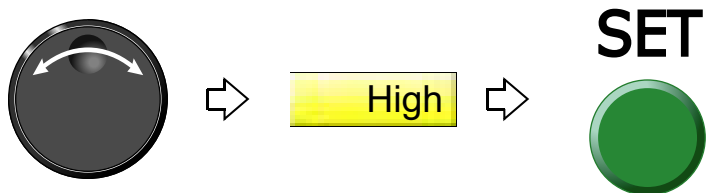

8-4. To change travel speed of the frame (Frame Travel Speed)

This function targets at origin return of the frame and/or offset travel.

8-4-1. Explanation on the screen

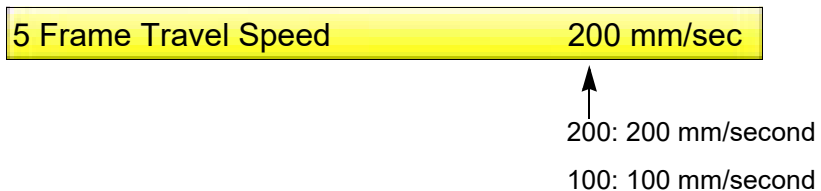

8-4-2. How to operate

The following is an example that Frame Travel Speed is set to 100 mm/sec".

(1) To open screen

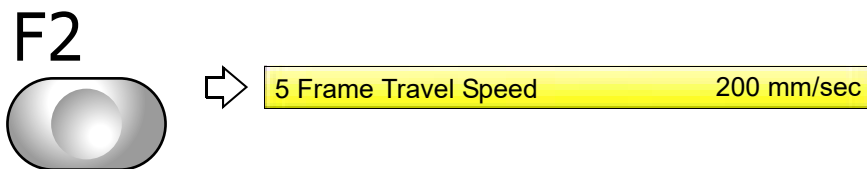

(2) To select Frame Travel speed



9. To edit design

9-1. To modify the stitch (Data Edit "Modify")

When this operation is performed in the middle of embroidery, data set will be canceled. If stitch length after change is different from that before change, a design will displace hereafter.

9-1-1. Explanation on the screen

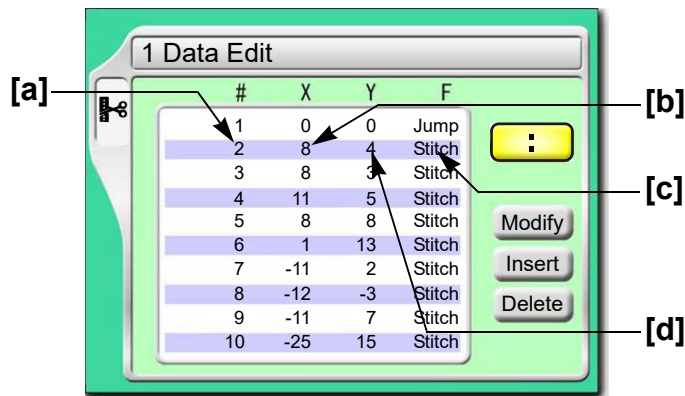

[a] Stitch No.

[b] X data (Data to move the frame in X-axis direction)

When the value is 8, the frame travel amount is 0.8 mm.

[c] Function Code(→p.268)

It is the code to indicate the role of the stitch.

[d] Y data (Data to move the frame in Y-axis direction)

When the value is 4, the frame travel amount is 0.4 mm.

9-1-2. How to operate

CAUTION

The original design will be overwritten after editing. Back up design data as necessary.

The following is an example that 20th stitch is changed to non-data (X: 0.0, Y:0.0) jump code.

(1) To open screen

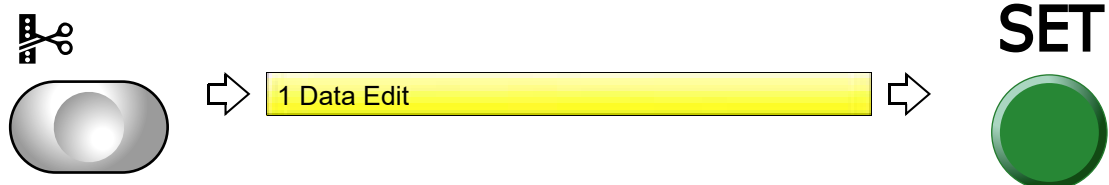

(2) To select a design



After that, select the stitch No. to change. There are following two types of selecting patterns.

(a) To select stitch No. by using search function, refer to the detail page.(→p.143)

(b) To select the stitch No. by the jog dial/jog shuttle, follow the explanation below.

[To select stitch No. by using the jog dial/jog shuttle]

(3) To select stitch No. to change

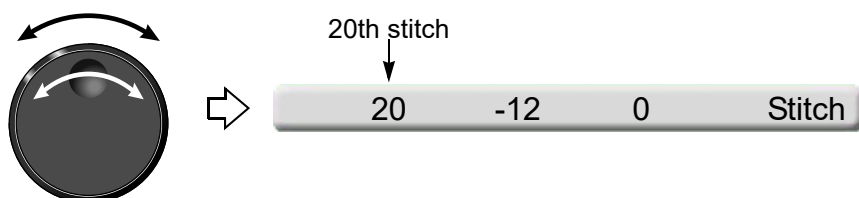

(4) To select "Modify"

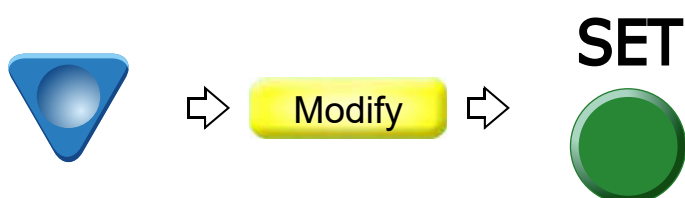

(5) To edit X data



(6) To edit Y data



(7) To modify the function code



(8) Decide the modification.

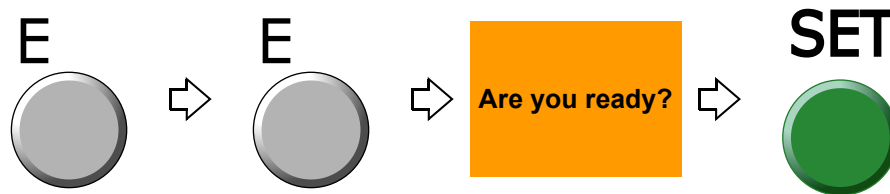

[To select stitch No. by using search function]

(3) To make search function effective

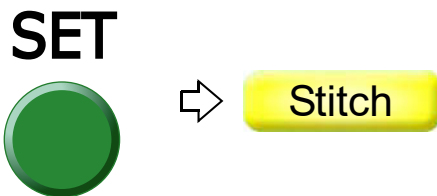

(4) To search stitch by function code

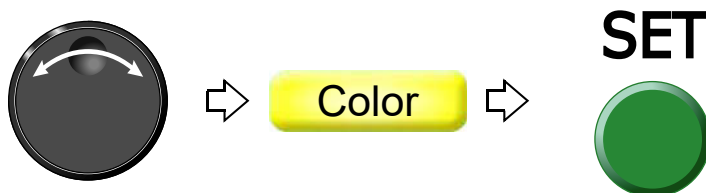

Pressing SET key will search the stitch including a function code "Color". Pressing SET key further will search the next stitch.

When there is no selected function code, display will not change.

(5) To complete the search and select "Modify"



1
2
3
4
5
6
7
8
9
10
11
12

(6) To edit X data

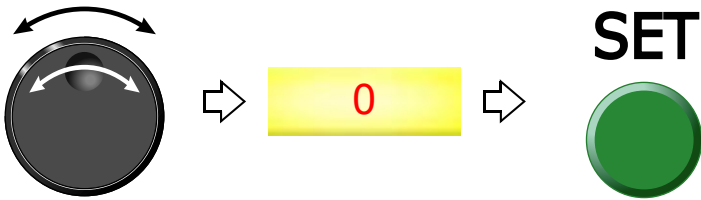

(7) To edit Y data

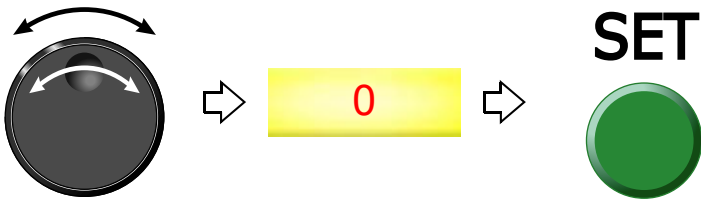

(8) To modify the function code



(9) Decide the modification.

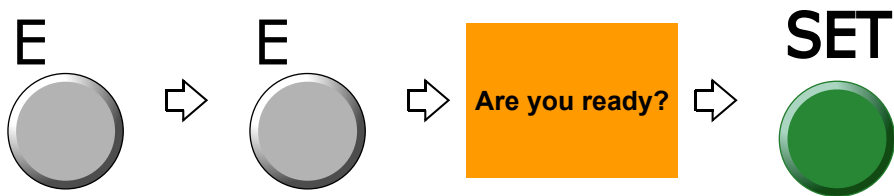

9-2. To insert the stitch (Data Edit "Insert")

When this operation is performed in the middle of embroidery, data set will be canceled. If the stitch with a length is inserted, a design will be displaced hereafter.

9-2-1. Explanation on the screen

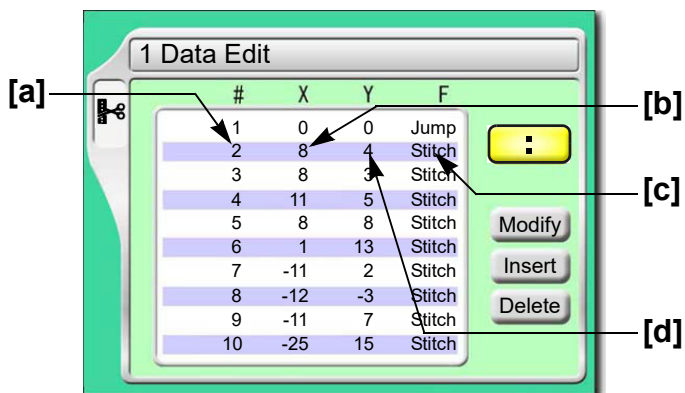

[a] Stitch No.

[b] X data (Data to move the frame in X-axis direction)

When the value is 8, the frame travel amount is 0.8 mm.

[c] Function Code(→p.268)

It is the code to indicate the role of the stitch.

[d] Y data (Data to move the frame in Y-axis direction)

When the value is 4, the frame travel amount is 0.4 mm.

9-2-2. How to operate

 **CAUTION**

 The original design will be overwritten after editing. Back up design data as necessary.

The following is an example that non-data (X: 0.0, Y:0.0) jump code is added to 120th stitch.

(1) To open screen

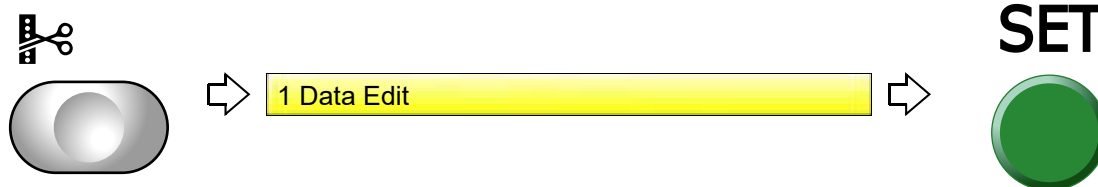

(2) To select a design



After that, select the stitch No. to insert. There are following two types of selecting patterns.

(a) To select stitch No. by using search function, refer to the detail page.(→p.147)

(b) To select the stitch No. by the jog dial/jog shuttle, follow the explanation below.

[To select stitch No. by using the jog dial/jog shuttle]

(3) To select stitch No. to insert

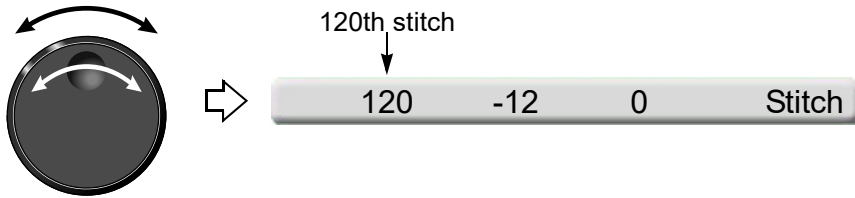

(4) To select "Insert"



(5) To execute insertion



(6) To select "Modify" to move the cursor

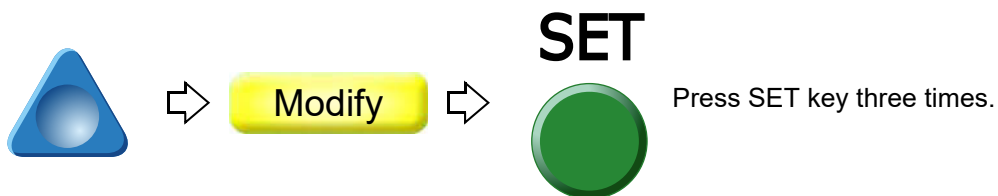

(7) To select "Jump".



(8) To decide insertion

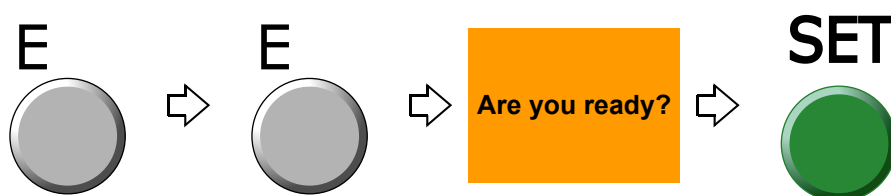

[To select stitch No. by using search function]

(3) To make search function effective

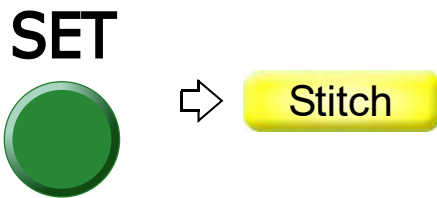

(4) To search stitch by function code

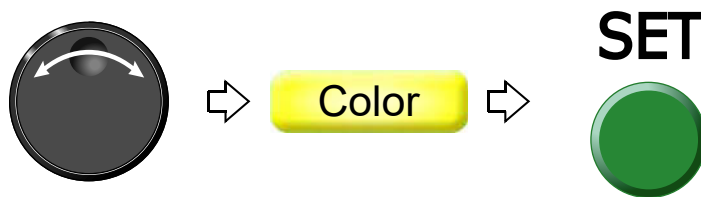

Pressing SET key will search the stitch including a function code "Color". Pressing SET key further will search the next stitch.

When there is no selected function code, display will not change.

(5) To complete the search and select "Insert"



(6) To execute insertion



(7) To select "Modify" to move the cursor

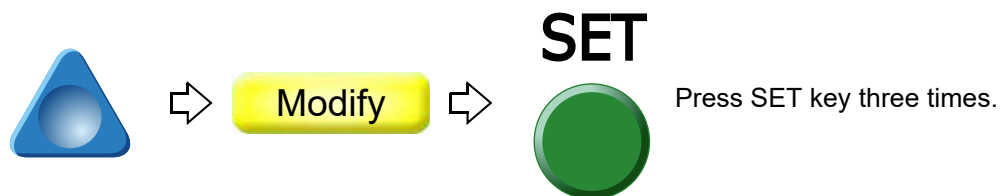

Press SET key three times.

1
2
3
4
5
6
7
8
9
10
11
12

(8) To select "Jump".



(9) To decide insertion

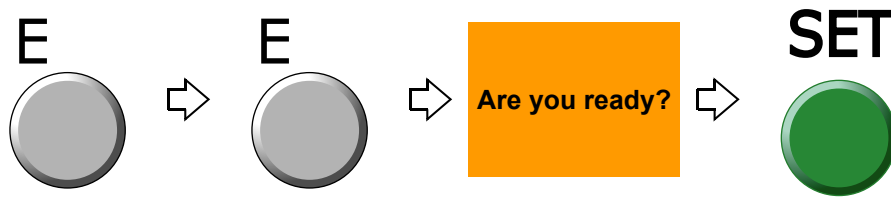

9-3. To delete the stitch (Data Edit "Delete")

When this operation is performed in the middle of embroidery, data set will be canceled. If the stitch having length is deleted, a design will displace hereafter.

9-3-1. Explanation on the screen

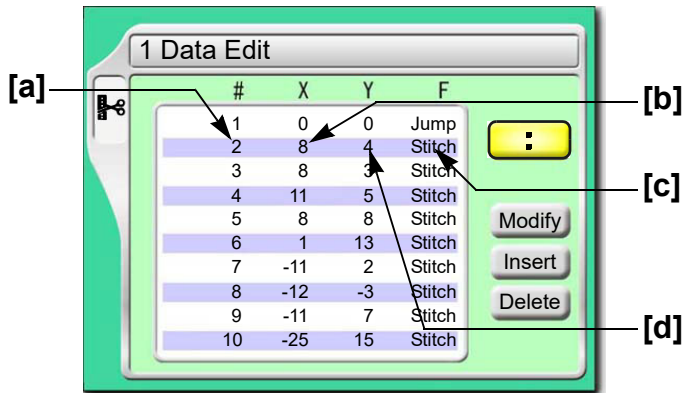

[a] Stitch No.

[b] X data (Data to move the frame in X-axis direction)

When the value is 8, the frame travel amount is 0.8 mm.

[c] Function Code(→p.268)

It is the code to indicate the role of the stitch.

[d] Y data (Data to move the frame in Y-axis direction)

When the value is 4, the frame travel amount is 0.4 mm.

9-3-2. How to operate

CAUTION

 The original design will be overwritten after editing. Back up design data as necessary.

The following is an example that 20th stitch is deleted.

(1) To open screen

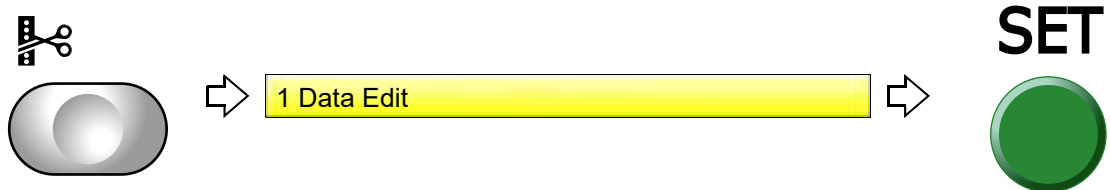

(2) To select a design



After that, select the stitch No. to delete. There are following two types of selecting patterns.

- (a)** To select stitch No. by using search function, refer to the detail page.(→p.150)
- (b)** To select the stitch No. by the jog dial/jog shuttle, follow the explanation below.

[To select stitch No. by using the jog dial/jog shuttle]

(3) To select stitch No. to delete

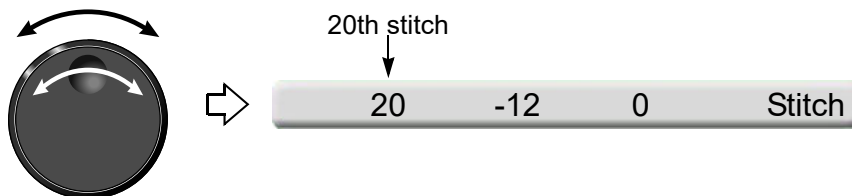

(4) To select "Delete"

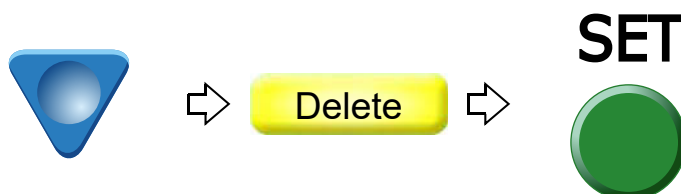

(5) To decide deletion

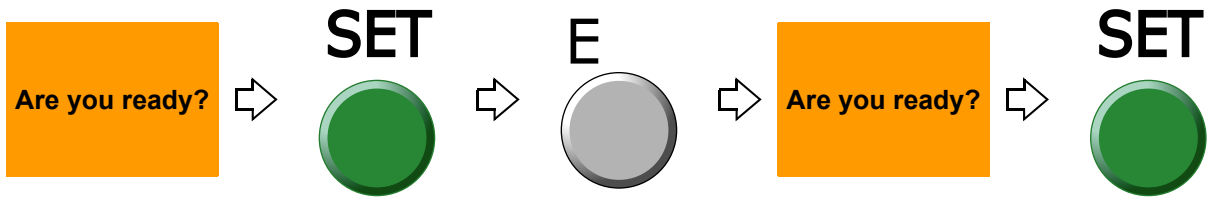

[To select stitch No. by using search function]

(3) To make search function effective

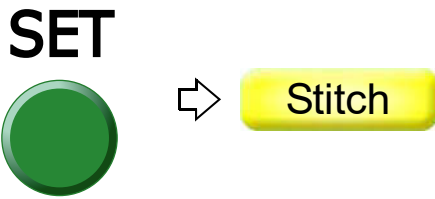

(4) To search stitch by function code

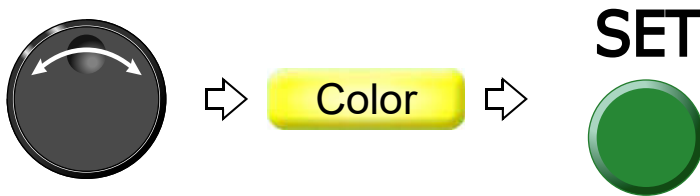

Pressing SET key will search the stitch including a function code "Color". Pressing SET key further will search the next stitch.

When there is no selected function code, display will not change.

(5) To select "Delete"



(6) To decide deletion

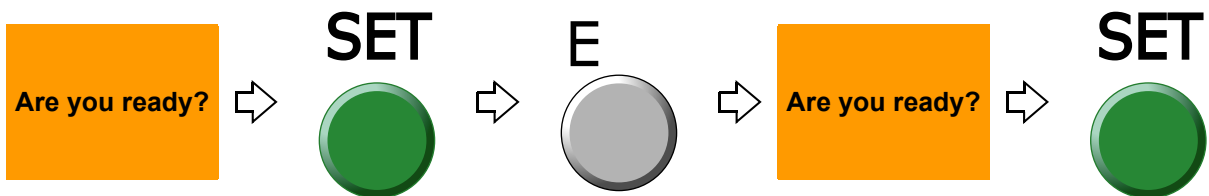

10. Setting and resetting of password

The password is set to "0000" at shipment.

10-1. To change password (Functional Limit of Password)

When you forget the password, install the software. The password will return to "0000". Regarding software installation, refer to the separate "System Handling Manual".

10-1-1. Explanation on the screen

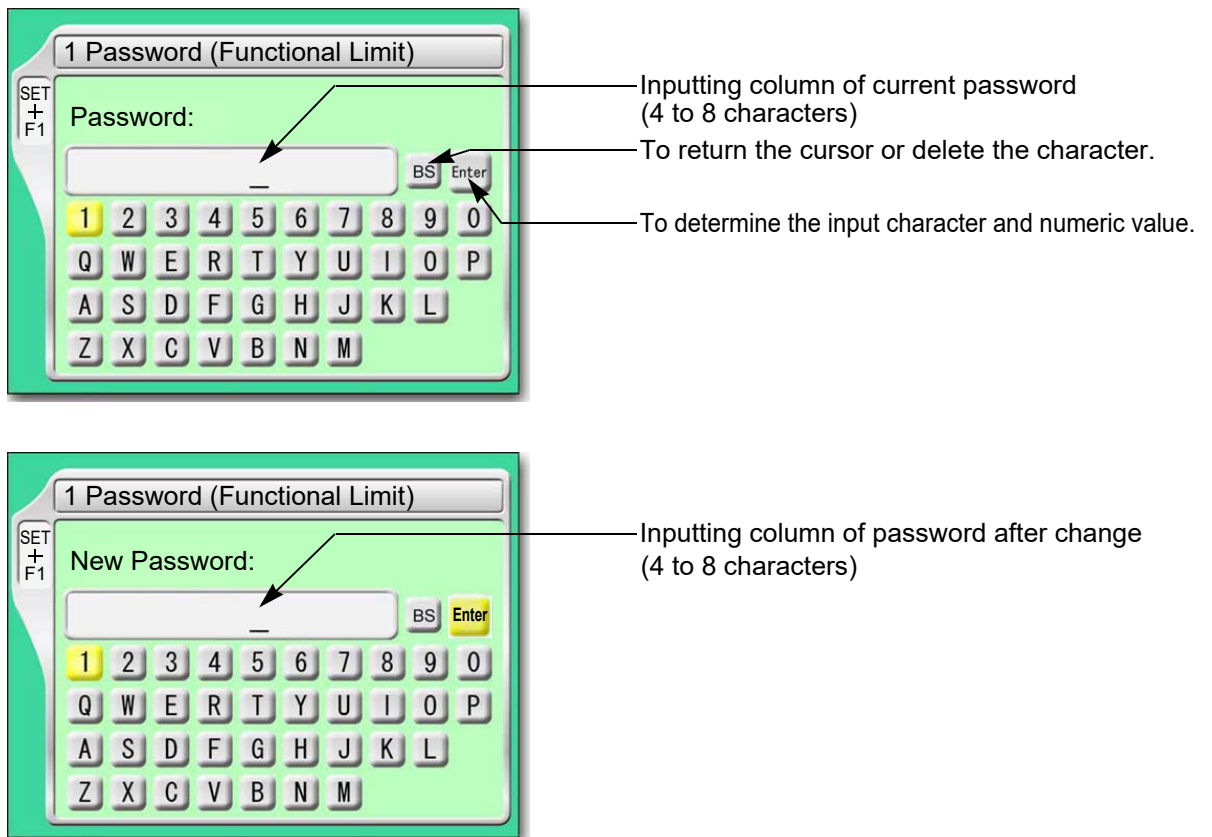

10-1-2. How to operate

The following is an example that the password is changed from "0000" to "ZY98".

- (1) Set to main screen.
- (2) To press F1 key while pressing SET

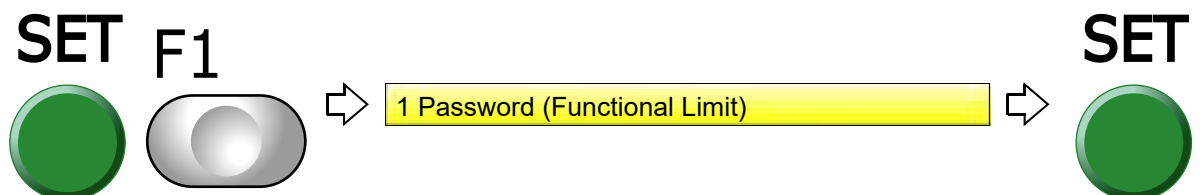

(3) To input the current password

(a) To select "0"

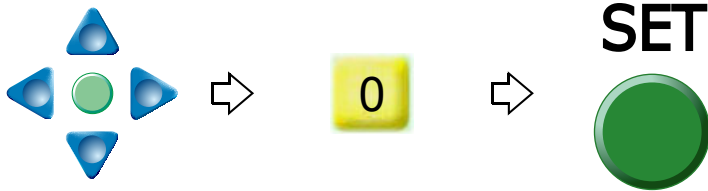

(b) To input the remaining password "0", "0", "0" in the same procedure.

(c) To decide



(4) To input password after change

(a) To select "Z"



(b) To select "Y"



(c) To select the remaining password "9", "8" in the same procedure

(d) To decide



- (5) To input password again after change
 - (a) To input password in the same procedure
 - (b) To decide



10-2. To cancel the password

The password is set for some function. Perform operation in the following procedure after canceling the password.

10-2-1. Explanation on the screen

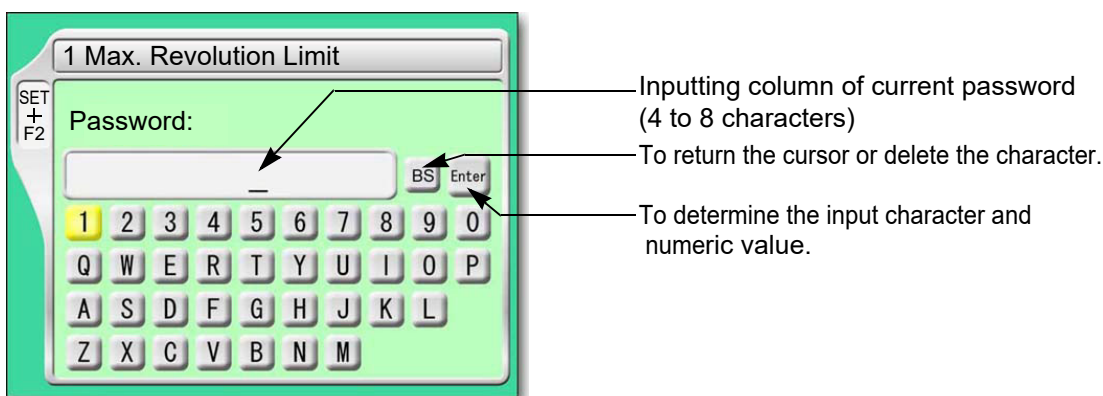

10-2-2. How to operate

The following is an example that the password "0000" is canceled.

- (1) To input password "0"

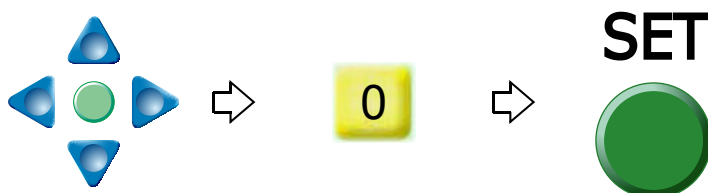

- (2) To input the remaining password "0", "0", "0" in the same procedure.

- (3) To decide

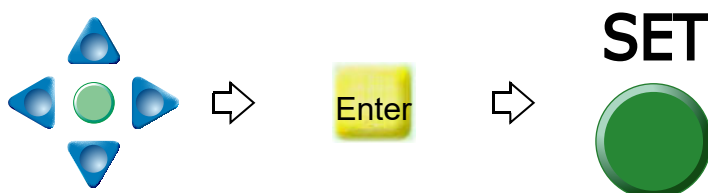

11. Various functions

11-1. To check the number of total stitches up to now (Total Stitch Counter)

11-1-1. Explanation on the screen

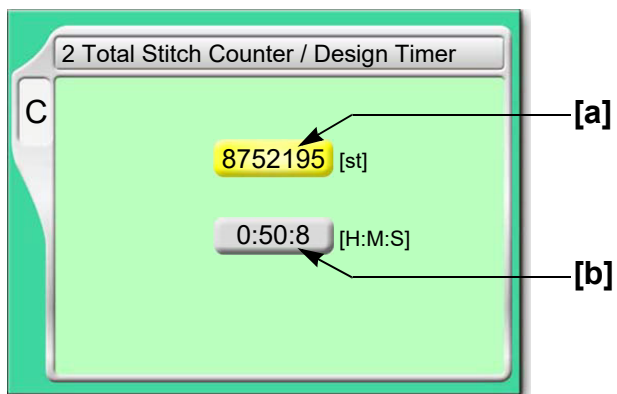

[a] The number of total stitches embroidered up to now. When resetting the value, select "0" and press SET key.

[b] Time from start after data set to the present (The screen shows an example of 50 minutes and 8 seconds.)

Counting continues even during sleep mode and turning OFF the power.

Embroidery time will be reset in the following conditions.

When the current embroidery is finished and the machine starts next

When data is set

11-1-2. How to operate

The following is an example that the total stitch counter is checked.

(1) To open screen



C screen will be displayed. Check the total stitch counter.

11-2. To color in every needle bar (Needle Bar Color)

Matching needle bar color with thread color used actually will display approximate image of finished stitching.

11-2-1. Explanation on the screen

TCMX-600 series

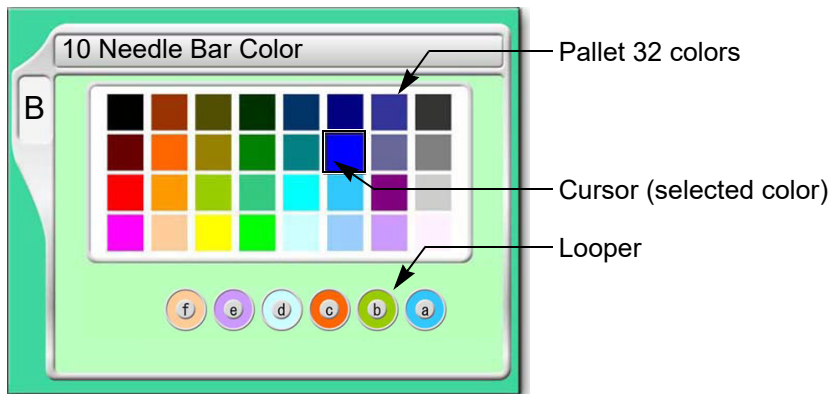

TCMX-mixed type series

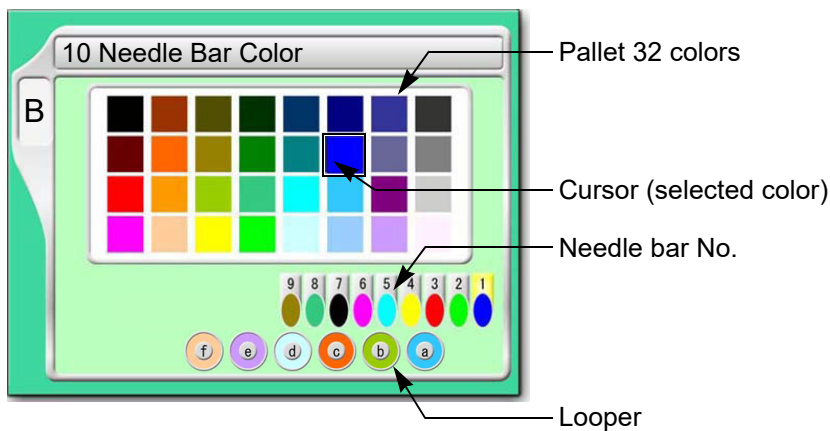

11-2-2. How to operate

The following is an example that the looper b is set to "Red".

(1) To open screen

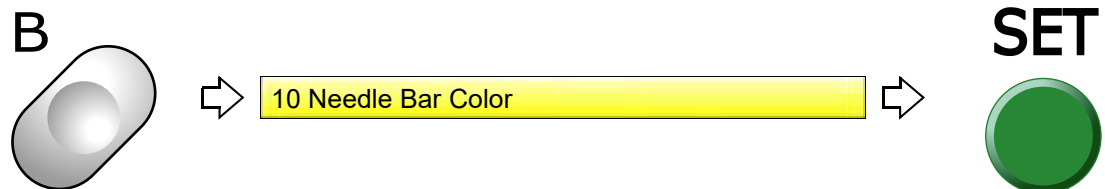

(2) To select the looper b

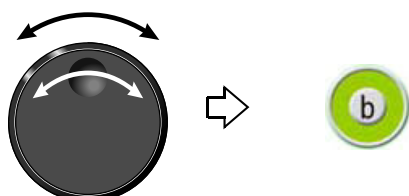

(3) To select color

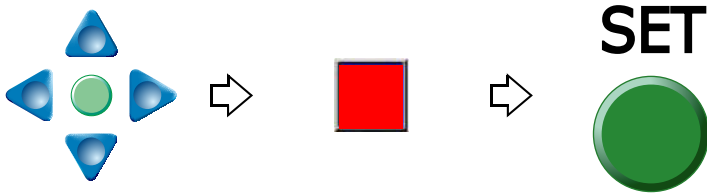

(4) To decide

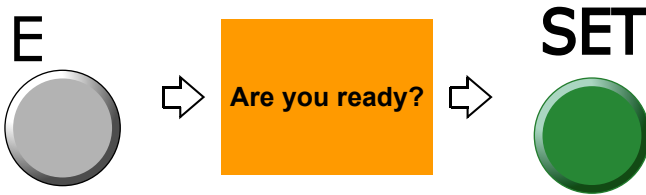

11-3. To check version of current software (Software Version)

11-3-1. Explanation on the screen

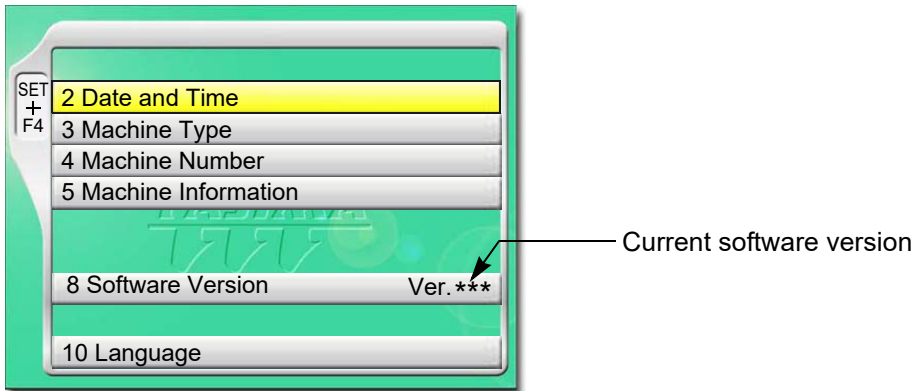

11-3-2. How to operate

The following is an example that the software version is checked.

(1) Set to main screen.

(2) To press F4 key while pressing SET

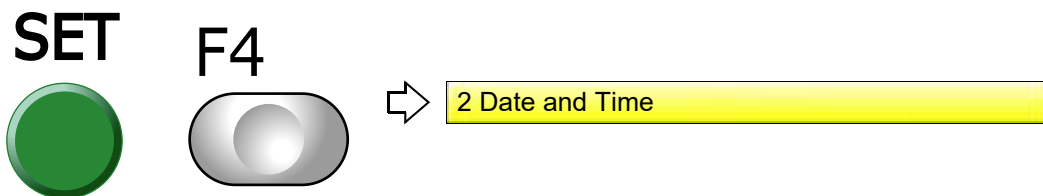

(3) Since SET + F4 screen will be displayed, check the version of the software.

11-4. To switch display language (Language)

11-4-1. Explanation on the screen

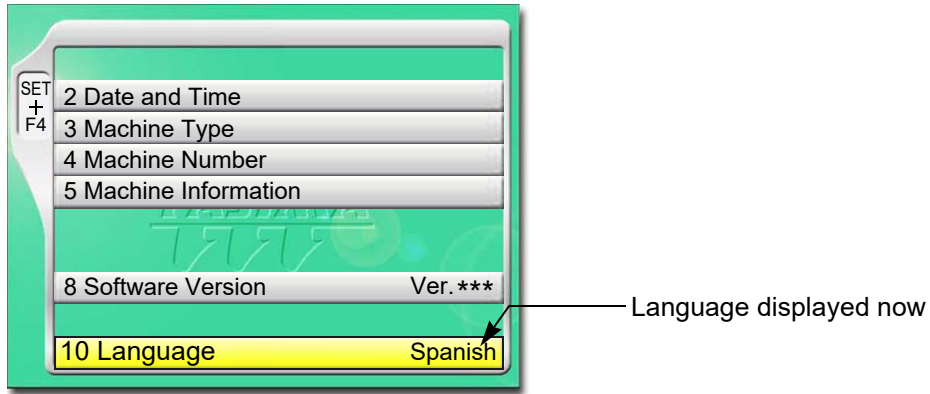

11-4-2. How to operate

The following is an example that the language is changed to "English".

- (1) Set to main screen.
- (2) To press F4 key while pressing SET

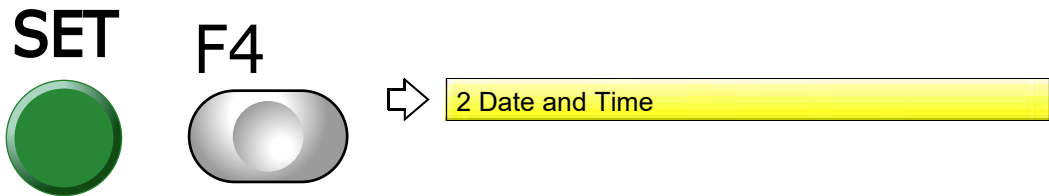

- (3) To press F4 key

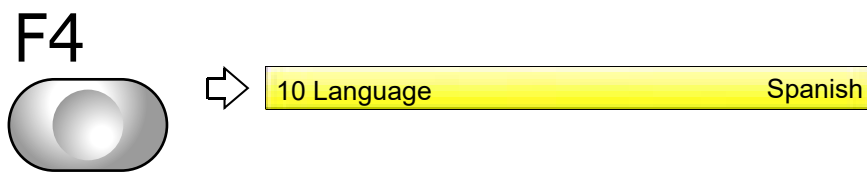

- (4) To select language



1
2
3
4
5
6
7
8
9
10
11
12

11-5. To release fixing of main shaft motor (weak brake)

It is the setting to release the fixing of the main shaft motor temporarily while the main shaft stops. This function is used for the maintenance of the machine mainly.

11-5-1. Explanation on the screen

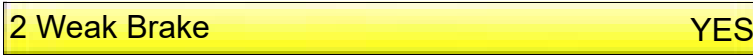

↑
YES:
The main shaft is fixed. (usual setting)
NO:
The main shaft is not fixed. The setting will be switched to YES after start of the machine.

11-5-2. How to operate

The following is an example that the main shaft motor is set to "not to fix".

- (1) Set to main screen.
- (2) To press F3 key while pressing SET

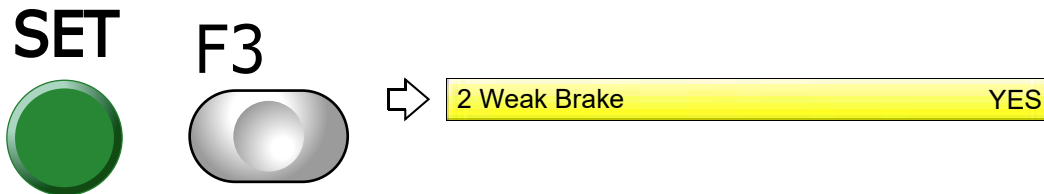

- (3) To select not to fix

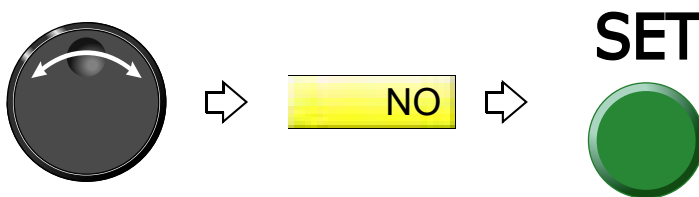

11-6. To lower the needle bar by manual operation (Manual Stop at Lower Dead Point)

Lower the needle bar by manual operation and keep the needle stuck in the fabric.

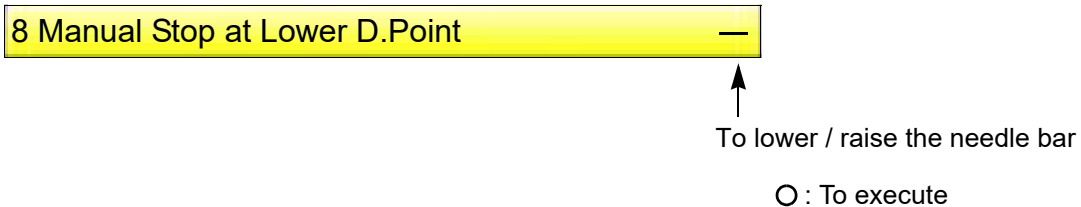
11-6-1. Explanation on the screen

This function cannot be used within the following frame travel interval.

- (a) Frame Back
- (b) Automatic color change (free setting) offset
- (c) Table offset

The following operations are not possible with the needle lowered.

- | | |
|--|--|
| (a) Frame Back | (g) Frame Origin Memory |
| (b) Frame Forward | (h) Power Resume |
| (c) Manual Color Change | (i) Up/down operation of Sequin device, and Adjusting mode |
| (d) Manual Head Selection | (j) Each Nipple Home Position Return |
| (e) Manual ATH | (k) Trace |
| (f) Automatic color change (free setting) offset | (l) Table offset |

The following operations are possible even with the needle lowered. However, remove the clips in advance in case of (a), (b) and (c).

- (a) Manual Frame Travel
- (b) Offset Return
- (c) Return to the design start position
- (d) Manual AFC Valve Switching
- (e) Manual AFC Sequence Switching
- (f) Each M-axis operation

11-6-2. How to operate

⚠ CAUTION

⊘ When performing this operation, do not put your hands etc. near the needle or on the machine table. Moving down of the needle bar could injure you.

The following is an example of lowering the needle bar by manual operation.

(1) To open screen

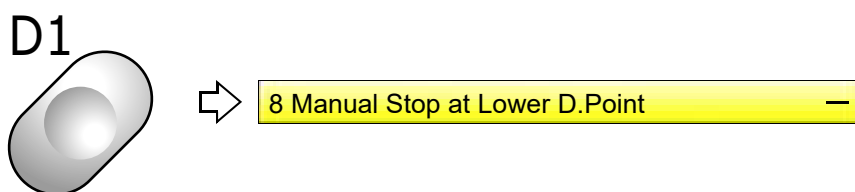

(2) To lower the needle bar

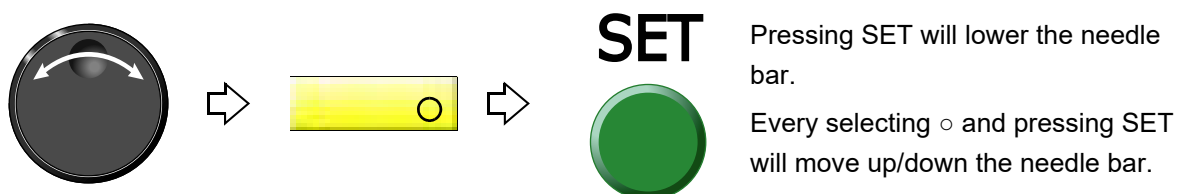

Chapter 7

Functions concerning frame movement

1. To return the frame (Frame Back) / to advance the frame (Frame Forward) 162
2. Necessary works after replacing the frame 168
3. To return the frame to the original position 169
4. To return the frame to the design start position 174
5. To move the frame to the position registered..... 176
6. To register frame position 181

1

2

3

4

5

6

7

8

9

10

11

12

1. To return the frame (Frame Back) / to advance the frame (Frame Forward)

1-1. To switch Frame Back / Frame Forward

1-1-1. Explanation on the screen

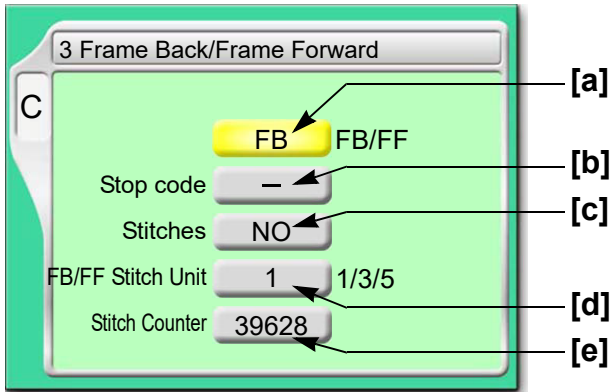

[a] Switching of FB (Frame Back) / FF (Frame Forward)

[b] To execute by Stop code(→p.163)

[c] To specify the number of stitches and execute(→p.163)

[d] To change the frame feed amount(→p.165)

[e] Current number of stitches. It is displayed only and cannot be changed.

1-1-2. How to operate

The following is an example of setting frame forward.

(1) To open screen

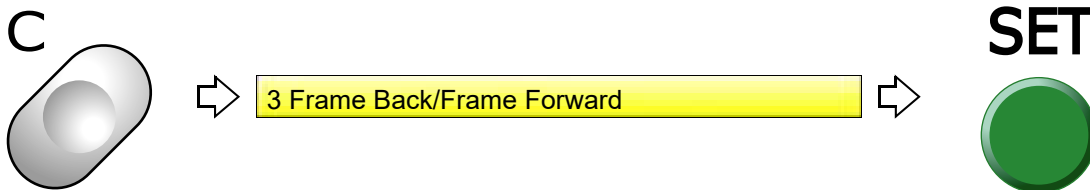

(2) To select FF (Frame Forward)

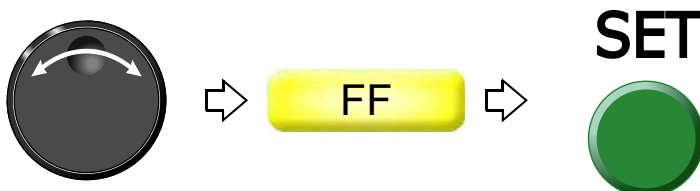

1-2. To execute by Stop code, to specify number of stitches to execute

1-2-1. Explanation on the screen

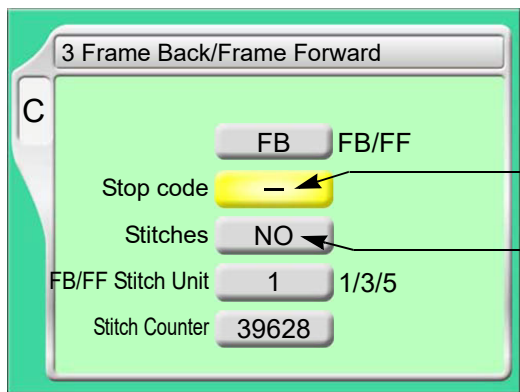

[a]

[b]

About [a] and [b]

In case of CM head, the frame will move after moving up/down of needle and working of ATH.

[a] To perform Frame Back or Frame Forward in Stop code

O: To execute

[b] To perform frame back or frame forward by specifying the number of stitches

NO: Not to perform

1 to end stitch:

To perform (to perform Frame Back or Frame Forward for the number of stitches)

1-2-2. How to operate



The following is an example of executing frame forward by Stop code.

(1) To open screen

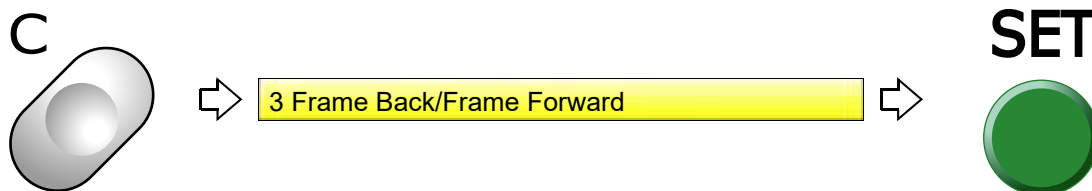

(2) To select FF (Frame Forward)

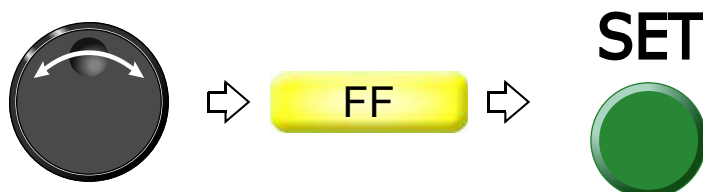

(3) To move the cursor to "Stop code"



(4) To perform Frame Forward in Stop code

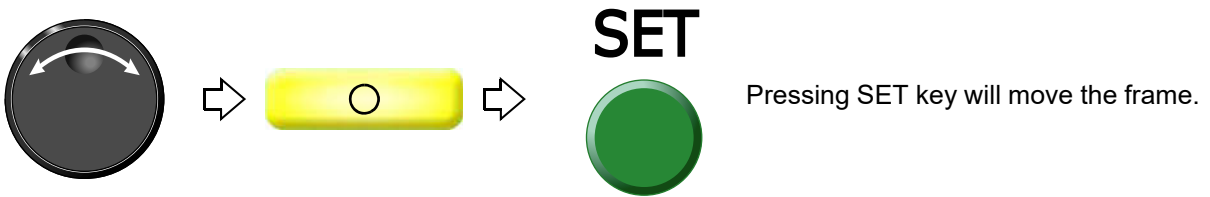

1-2-3. How to operate

When performing this operation, do not put your hands, etc. on the table. Moving the frame could injure you.

The following is an example of specifying the number of stitches and executing frame forward.

(1) To open screen

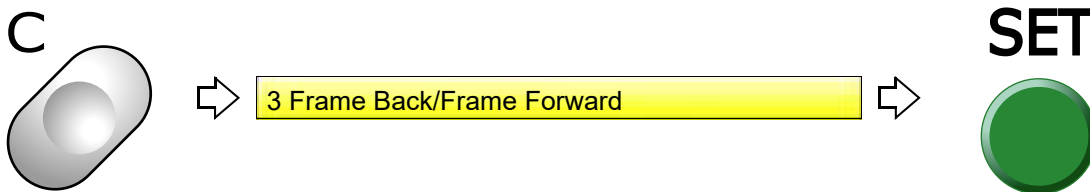

(2) To select FF (Frame Forward)

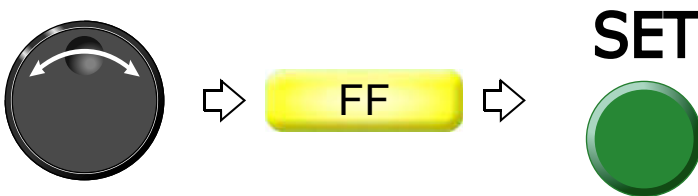

(3) To move the cursor to "Specification by the number of stitches"



(4) To input the number of stitches and execute

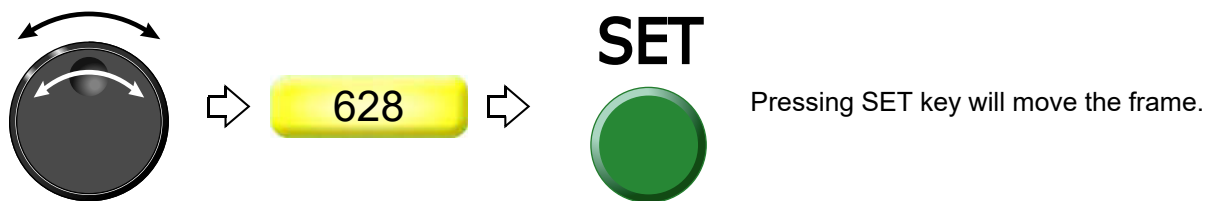

1-3. To change a frame feed amount of frame back / frame forward

This function sets a frame feed amount when 11-stitches or more is successive due to the operation of frame back/frame forward by the stop switch or the bar switch.

1-3-1. Explanation on the screen

Frame feed amount

- 1: Feed the frame by 1-stitch unit.
- 3: Feed the frame by 3-stitches unit.
- 5: Feed the frame by 5 stitches unit.

1-3-2. How to operate

The following is an example of setting the frame feed amount to "5".

(1) To open screen

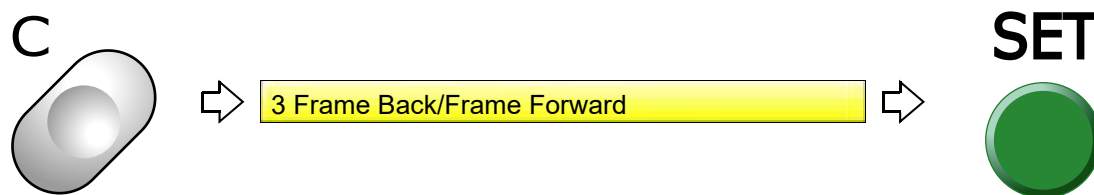

(2) To move the cursor to "FB/FF Stitch unit"



(3) To select frame feed amount

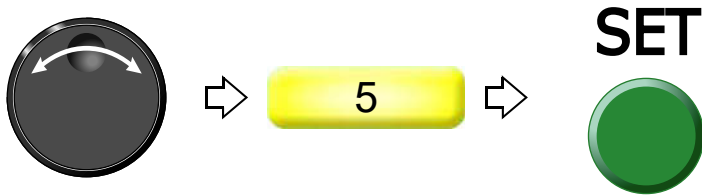

1-4. To set All Head Sewing Start Point (Frame Back All head Sew) (FM head)

This setting sets "All Head Sewing Start Point After Frame Back" and "Whether the machine stops at the position just before All Head Sewing Start Point or not". This function is applied for TCMX-mixed type series.

1-4-1. Explanation on the screen

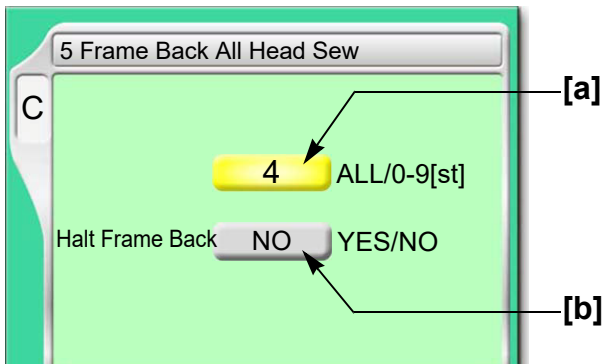

[a] Frame Back All head Sew

ALL: All heads sew the whole section of frame back.

When ALL is selected, "Halt Frame Back" is fixed to NO.

0 - 9: All Head Sewing Start Point

The value indicates the number of stitches from a frame back start point.

In case of TCMX-mixed type series, the sequin needle sews from the frame back start point irrespective of the value of all head sewing start position.

[b] The machine stops at the position just before All Head Sewing Start Point.

YES: To stop

NO: Not to stop

1-4-2. How to operate

The following is an example of setting All Head Sewing Start Point to "3" and setting to "Stop" at the position just before All Head Sewing Start Point.

(1) To open screen



(2) To select All Head Sewing Start Point

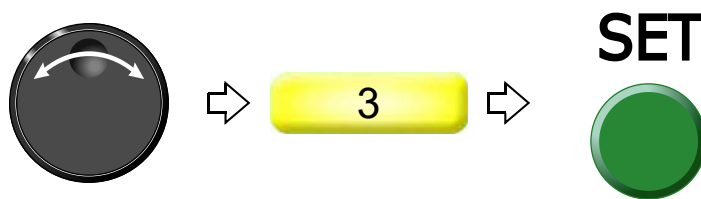

(3) The machine stops at the position just before All Head Sewing Start Point.



1
2
3
4
5
6
7
8
9
10
11
12

2. Necessary works after replacing the frame

2-1. To change frame type

2-1-1. Explanation on the screen

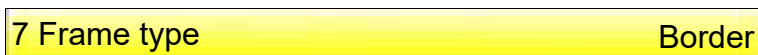

↑
Frame Type

Border: Border frame

Border 2: Border frame + Aluminum square frame

When you want to do fine adjustment for finishing of sewing, perform the following setting.

7-8. To adjust stitching length according to a stitch length (Frame Drive Adjustment)(
→p.136)

2-1-2. How to operate

The following is an example of setting the frame type to "Border 2".

(1) To open screen

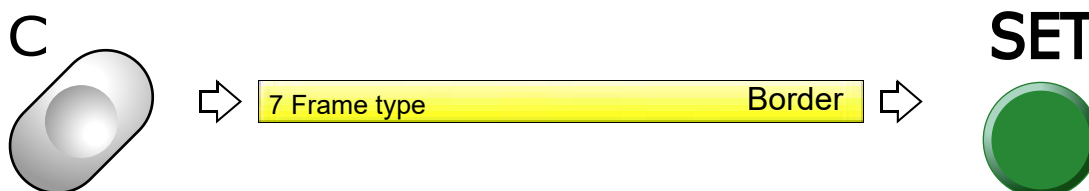

(2) To select the frame

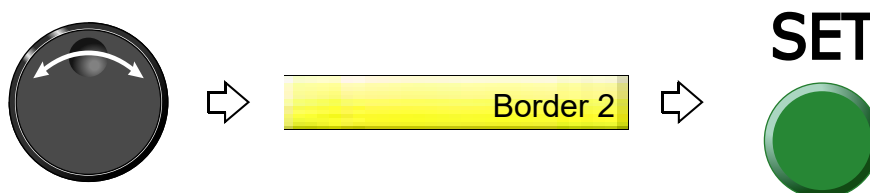

After that, code No.2CA will be displayed. Therefore, turn OFF and ON the power.

3. To return the frame to the original position

3-1. To return the moved frame to the previous position (Manual Offset)

This function is effective only when the frame is moved manually after stopping the machine in the middle of embroidery.

3-1-1. Explanation on the screen



↑
To return the frame to the original position

○ : To execute

3-1-2. How to operate



The following is an example of executing manual offset.

(1) To open screen



(2) To perform manual offset

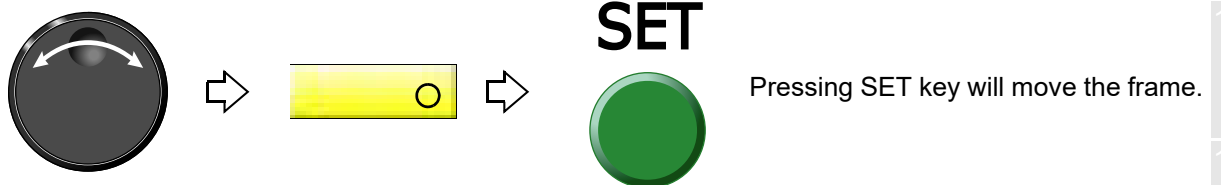

3-2. To return moved frame to original position and start operation (Return the frame after manual frame travel)

This function is effective only when the frame is moved manually after stopping the machine in the middle of embroidery.

3-2-1. Explanation on the screen



↑
Setting to return or not to return the frame by operating the bar switch or the start switch

YES:

The frame will return to the original position and the machine will start operation.

NO:

The frame will not return. The operation will start from the position after frame travel.

3-2-2. How to operate

The following is an example of returning the frame to the original position and starting the operation.

(1) Set to main screen.

(2) Press F2 key while pressing SET key.

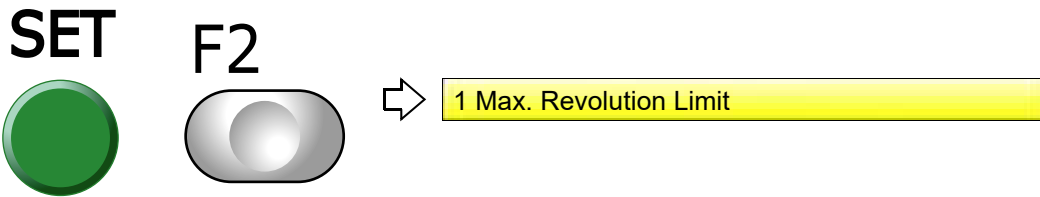

(3) Press F2 key.

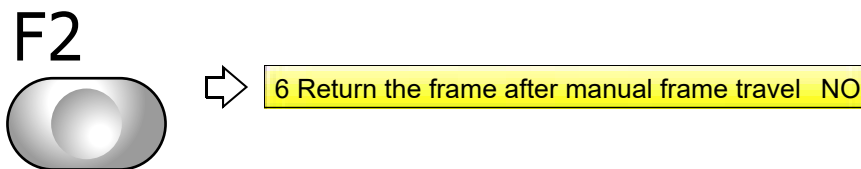

(4) To return the frame by operating the bar switch or the start switch, and start the operation.



3-3. To prevent displacement of design when the power is shut off during operation (Power resume)

This function works on condition that the frame origin is memorized correctly. If it is wrong, the frame will not return to the correct position.

3-3-1. Explanation on the screen

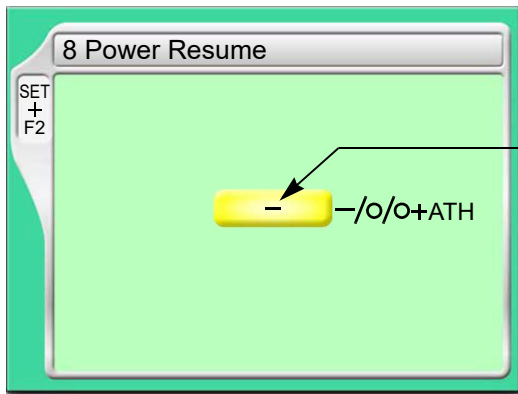

To return the frame to several stitches before the position where power was shut off

O : To execute

O+ATH : To execute after thread trimming

3-3-2. How to operate

CAUTION

When performing this operation, do not put your hands etc. near the needle or on the table. Moving needle bar or frame could injure you.

The following is an example of executing Power resume.

- (1) Set to main screen.
- (2) Press F2 key while pressing SET key.

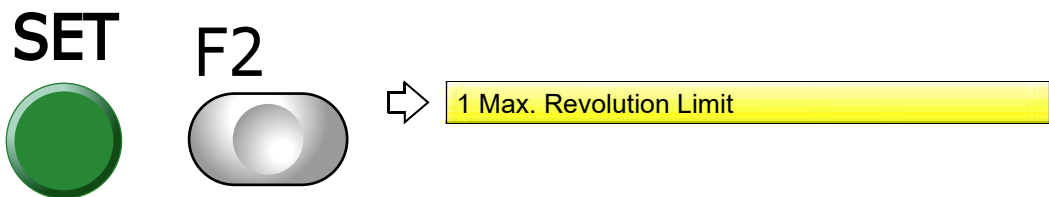

- (3) Press F2 key.

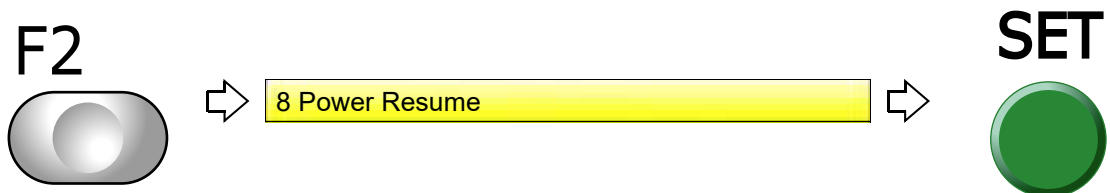

(4) To execute after thread trimming

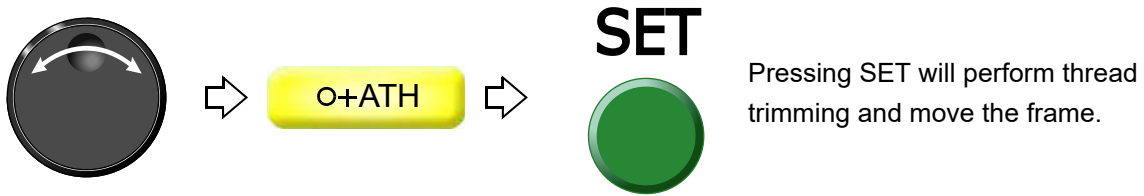

3-4. To memorize frame origin (Frame origin memory)

Frame origin is an anchoring point (X:0.0, Y:0.0) to calculate the current frame position. Position of frame origin differs depending on model.

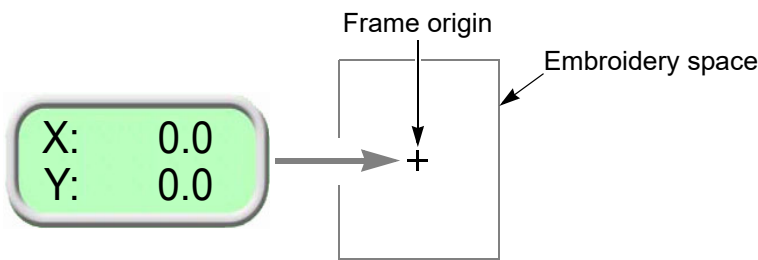

Execute this function in case of the following condition.

- There is a possibility that the frame was moved by hand in the state of power OFF or during sleep mode in such a case as changing frame.
- After installation of software
- When frame driver is changed
- When frame type is changed

When a frame origin is wrong, the following troubles will occur.

- Frame coordinates are not displayed correctly.
- The frame does not return to the interrupted position even after performing Power resume.
- Position of frame limit gets out of alignment.

3-4-1. Explanation on the screen

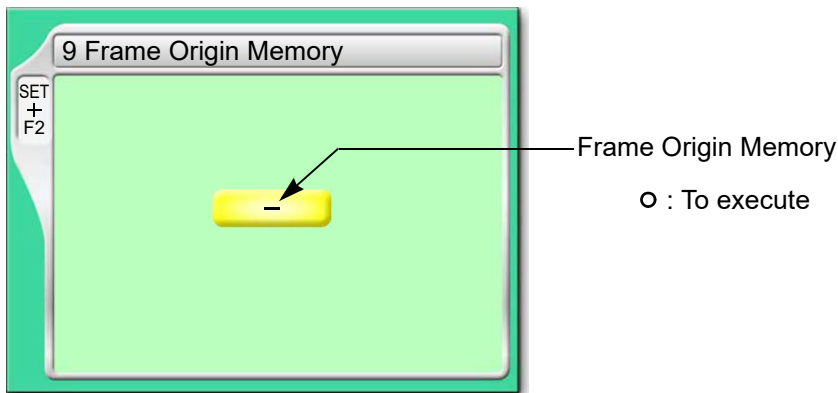

3-4-2. How to operate

! CAUTION

⊘ When performing this operation, do not put your hands, etc. on the table. Moving the frame could injure you.

The following is an example of executing frame origin memory.

- (1) Set to main screen.
- (2) Press F2 key while pressing SET key.

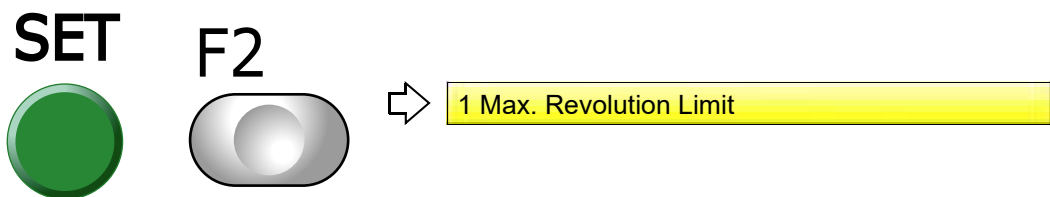

- (3) Press F2 key.

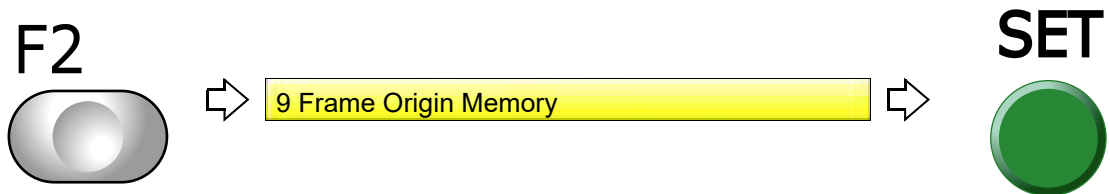

- (4) Execute Frame Origin Memory.

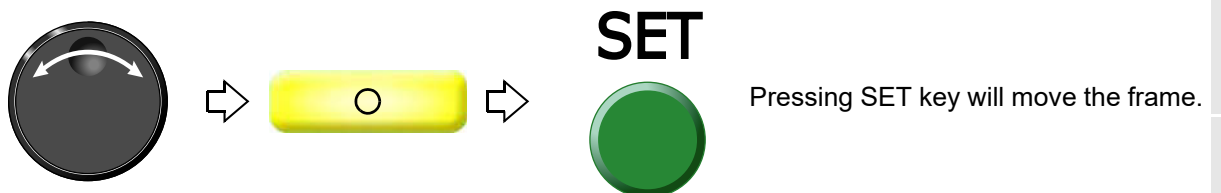

1
2
3
4
5
6
7
8
9
10
11
12

4. To return the frame to the design start position

4-1. To return the frame to the design start position manually (Return to the design start position)

This function makes the frame return to the design start position in the middle of embroidery when you stopped the machine.

4-1-1. Explanation on the screen

4 Return to the design start position —

↑
To return the frame to the design start position

○ : To execute

4-1-2. How to operate

⚠ CAUTION

⊘ When performing this operation, do not put your hands, etc. on the table. Moving the frame could injure you.

The following is an example of executing design start position return.

(1) To open screen

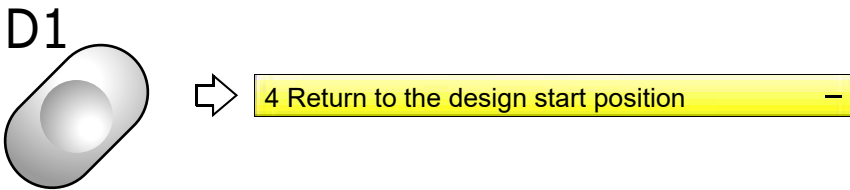

(2) To execute design start position return

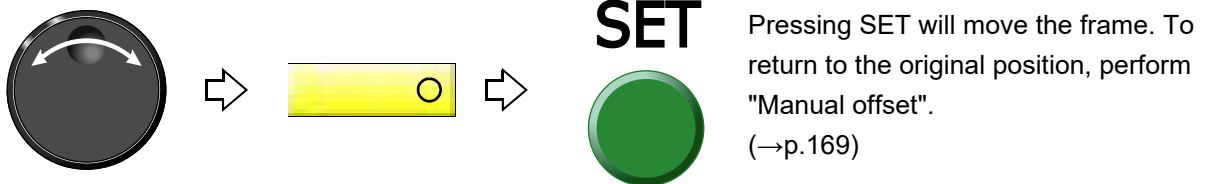

4-2. To return the frame to the design start position automatically (Auto Origin Return)

This is the setting to return the frame to the design start position automatically after embroidery is finished.
When Automatic offset is set, the frame will return to an offset start position.(→p.176)

4-2-1. Explanation on the screen



4-2-2. How to operate



The following is an example of setting Automatic origin return.

(1) To open screen

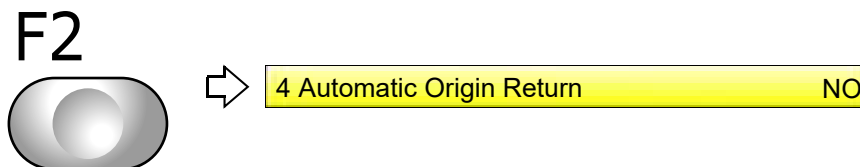

(2) To make auto origin return effective



5. To move the frame to the position registered

5-1. To move the frame automatically at the start and the end of embroidery (Automatic Offset)

This is the setting to move the frame automatically so that replacement of the frame and the fabric to be stretched can be performed easily. Perform this setting after data set. Setting contents here will be added in a design. So, when you embroider this design next time, setting again will be unnecessary.

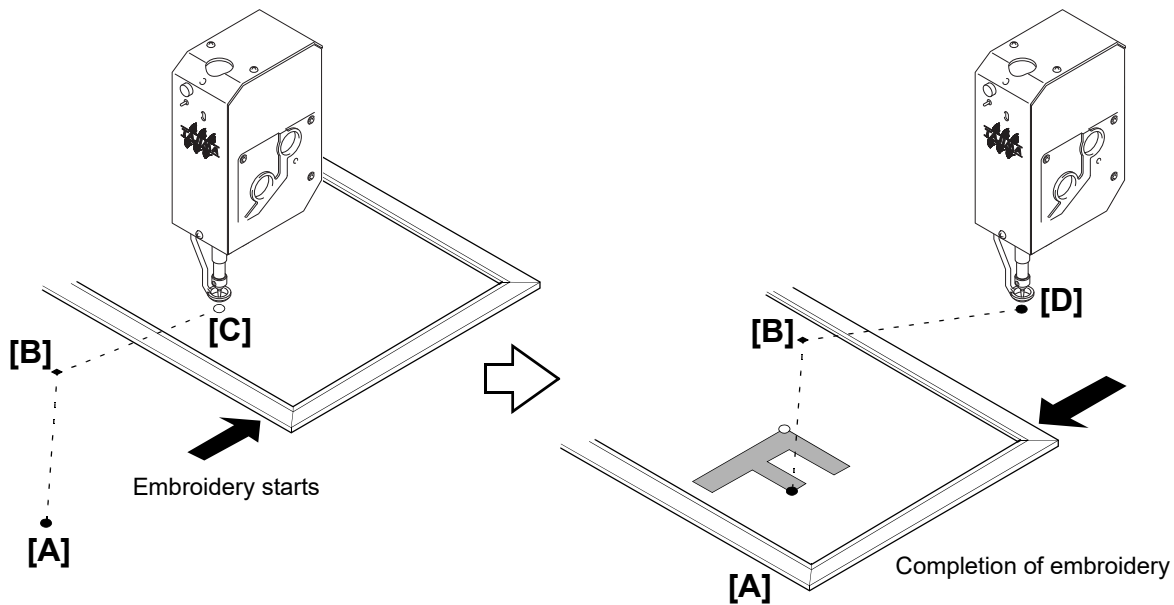

- (1) At the start of embroidery, the frame will pass from the offset start position [A] through the offset middle position [B] and move to the design start position [C] by the operation of bar switch or start switch.
- (2) When embroidery is finished, the frame will pass from the design end point [D] to the offset start position [A] through the offset middle position [B].

5-1-1. Explanation on the screen

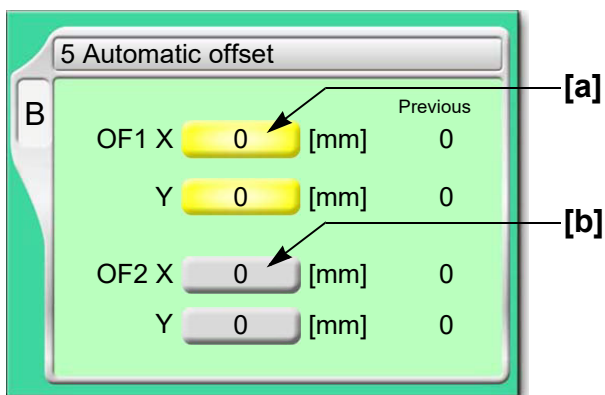

[a] Offset middle position [B in the figure above]



The position where the frame will pass. This position is arbitrarily set. Set it when embroidered material hits the machine during the frame travel.

[b] Offset start position [A in the figure above]

The position where the frame has come to the front. Changing the frame and the fabric to be stretched will be performed here.

5-1-2. How to operate

! CAUTION

-  When performing this operation, do not put your hands, etc. on the table. Moving the frame could injure you.
-  At the start and the end of embroidery, do not put your hands etc. on the table. Moving frame could injure you.

The following is an example of performing Automatic offset.

- (1) To decide an embroidery design (to perform data set)
- (2) To move the frame to the design start position [C]
- (3) To open screen



- (4) To decide OF1 (Offset Middle Position [B])

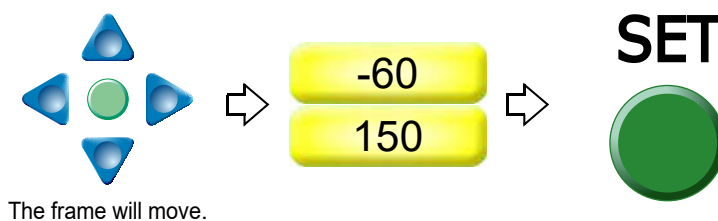

(5) To decide OF2 (Offset Start position [A])

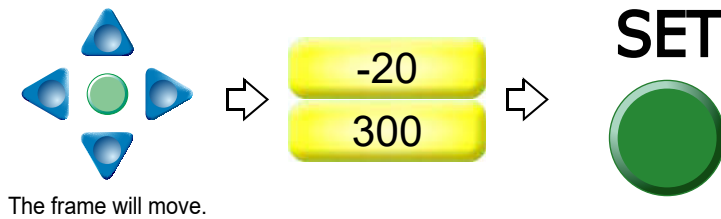

To cancel setting for Automatic offset, set values of OF1 and OP2 described above to "0".

5-2. To move the frame automatically at the start, in the middle and the end of embroidery

This function is the setting to move the frame automatically so that replacement of the frame, works for applique and change of fabric to be stretched can be performed easily.

The figure below is an example of movement for FM head, and CM head also moves in the same way.

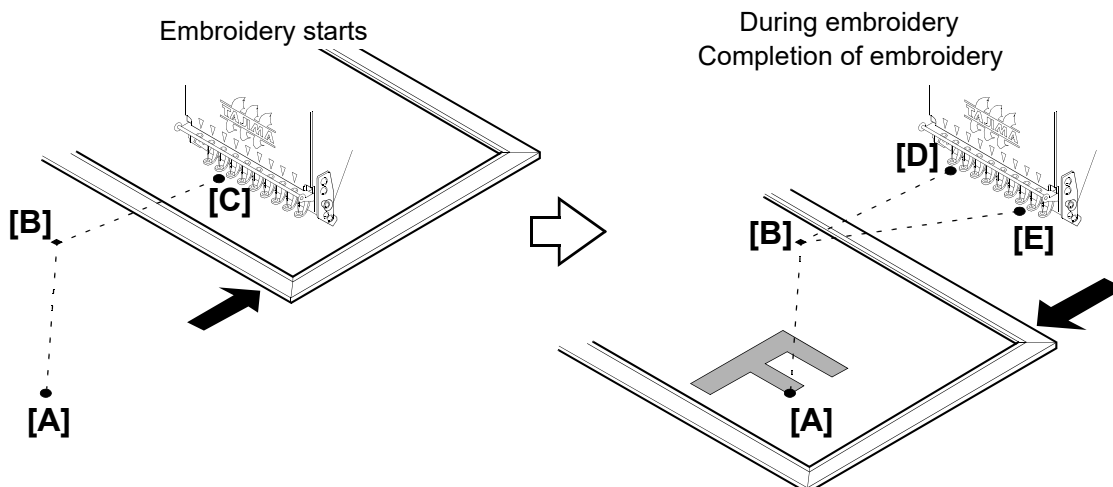

- (1) At the start of embroidery, the frame will pass from the offset start position [A] through the offset middle position [B] and move to the design start position [C] by the operation of bar switch or start switch.
- (2) During embroidery, the frame will return from the color change point [D] to the offset start position [A] through the offset middle position [B]. After performing works for applique here, the frame will move to the color change point [D] through the offset middle position [B], then start embroidery again by switch operation.
- (3) When embroidery is finished, the frame will pass from the design end point [E] through the offset middle position [B], then move to the offset start position [A].

5-2-1. Explanation on the screen

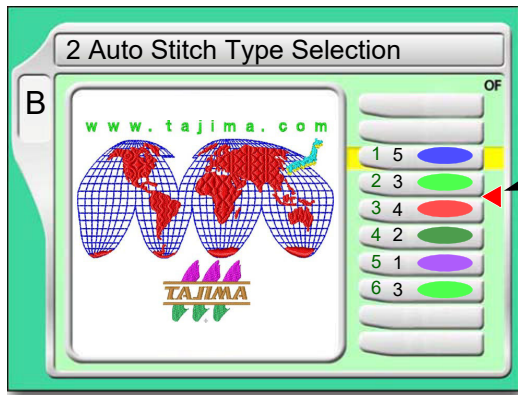

Offset mark

After step 2 is finished, the frame will return to the offset start position [A] automatically. To move the frame, the setting of "Automatic offset" is necessary. (→p.176)

If "Automatic Offset" is not set, the frame will move to the design start position [C].

5-2-2. How to operate

The following is an example of inserting the offset mark between step 2 and step 3.

(1) To open screen

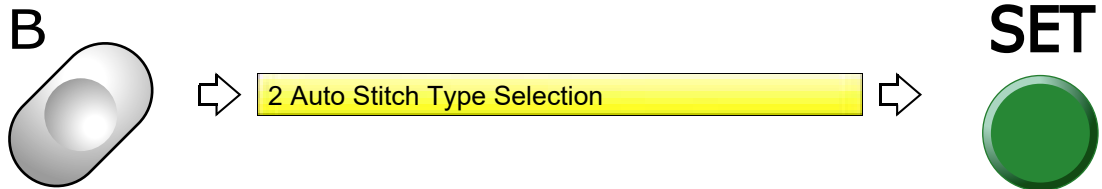

(2) To select step to insert offset mark

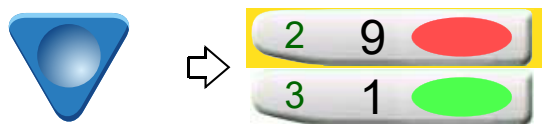

(3) To insert offset mark

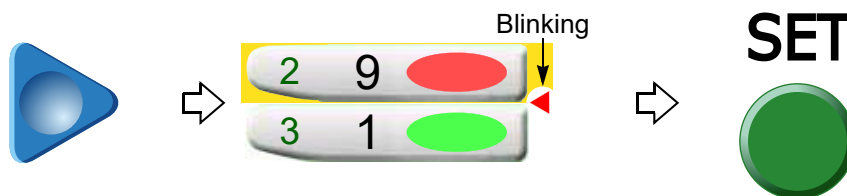

To delete offset mark

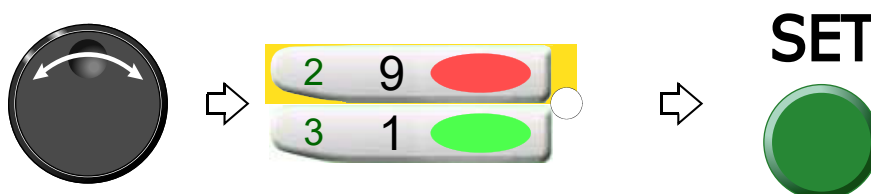

5-3. To return the frame to the offset start position manually (Return to the offset origin)

This function makes the frame return to the offset start position in the middle of embroidery when you stopped the machine. It is possible to operate only when Automatic offset is set. The offset middle position is not passed.

5-3-1. Explanation on the screen



↑
To return the frame to offset start position

○ : To execute

5-3-2. How to operate



The following is an example of executing offset return.

(1) To open screen

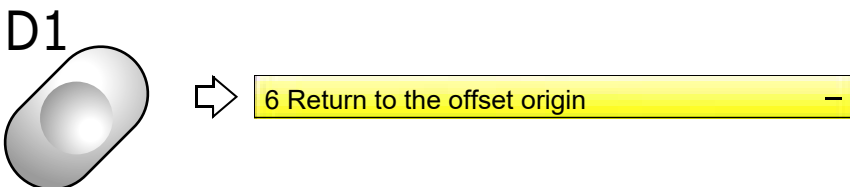

(2) To execute offset return

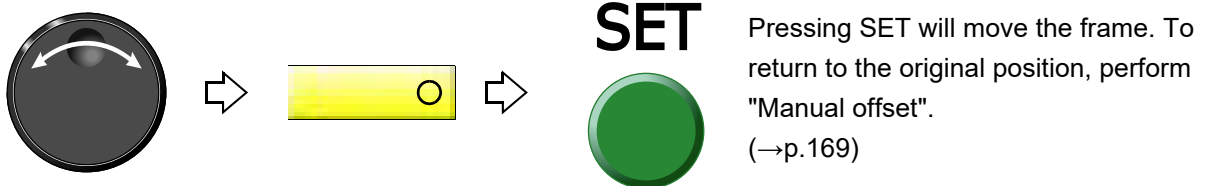

6. To register frame position

6-1. To register the frame position to make threading easily (table offset position)

This function targets the model equipped with table offset switch. Pressing the table-offset switch will set position (the table-offset position) to where the frame moves.

6-1-1. Explanation on the screen

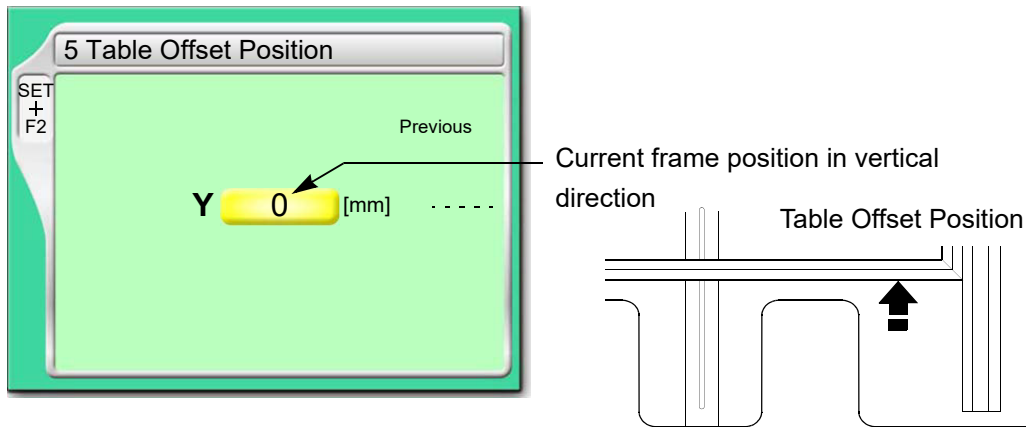

6-1-2. How to operate

The following is an example of setting the table offset position.

- (1) Set to main screen.
- (2) Press F2 key while pressing SET key.

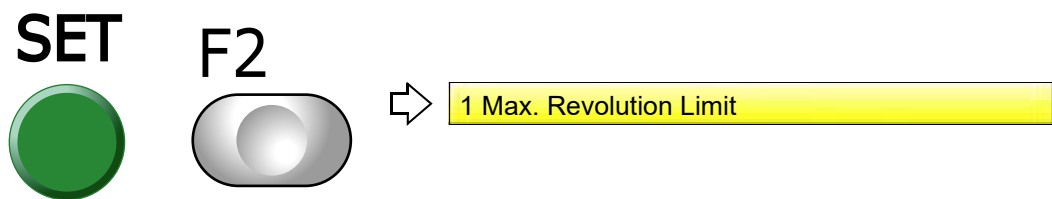

- (3) Press F2 key.

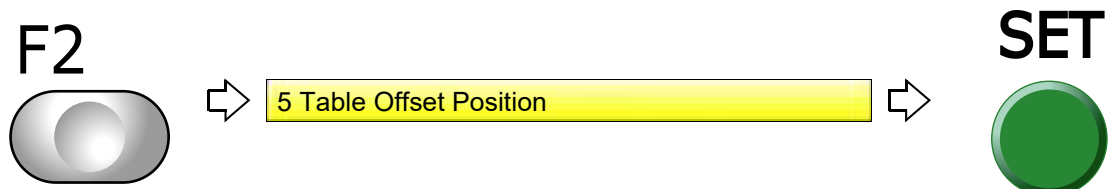

- (4) To set table offset position



Chapter 8

Function concerning storing and deleting of design

1. Design stored in the machine memory184
2. Design saved in USB memory.....196

1

2

3

4

5

6

7

8

9

10

11

12

1. Design stored in the machine memory

1-1. To delete a design (Memory Delete)

1-1-1. Explanation on the screen

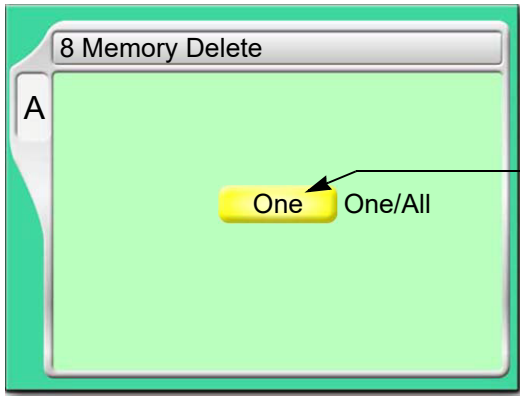

How to delete a design

One: The selected design is deleted one by one.

All: All designs are deleted at once.

1-1-2. How to operate

The following is an example of deleting a selected design.

(1) To open screen

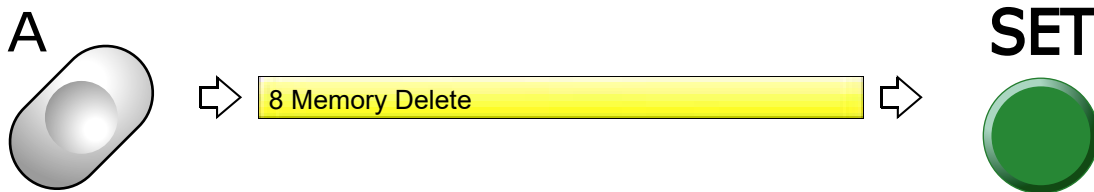

(2) Select a deleting method.

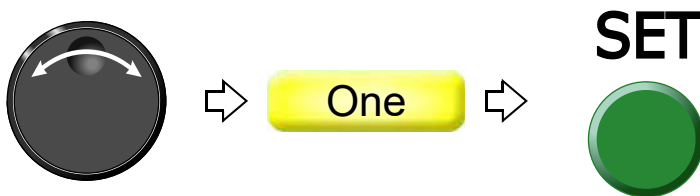

(3) To select and decide a design

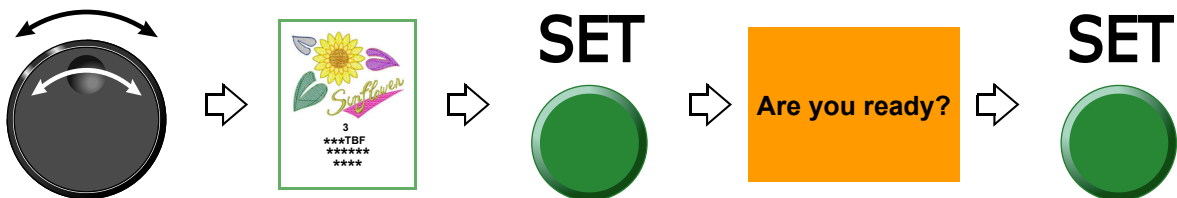

1-2. To move a design (Movement of design)

1-2-1. Explanation on the screen

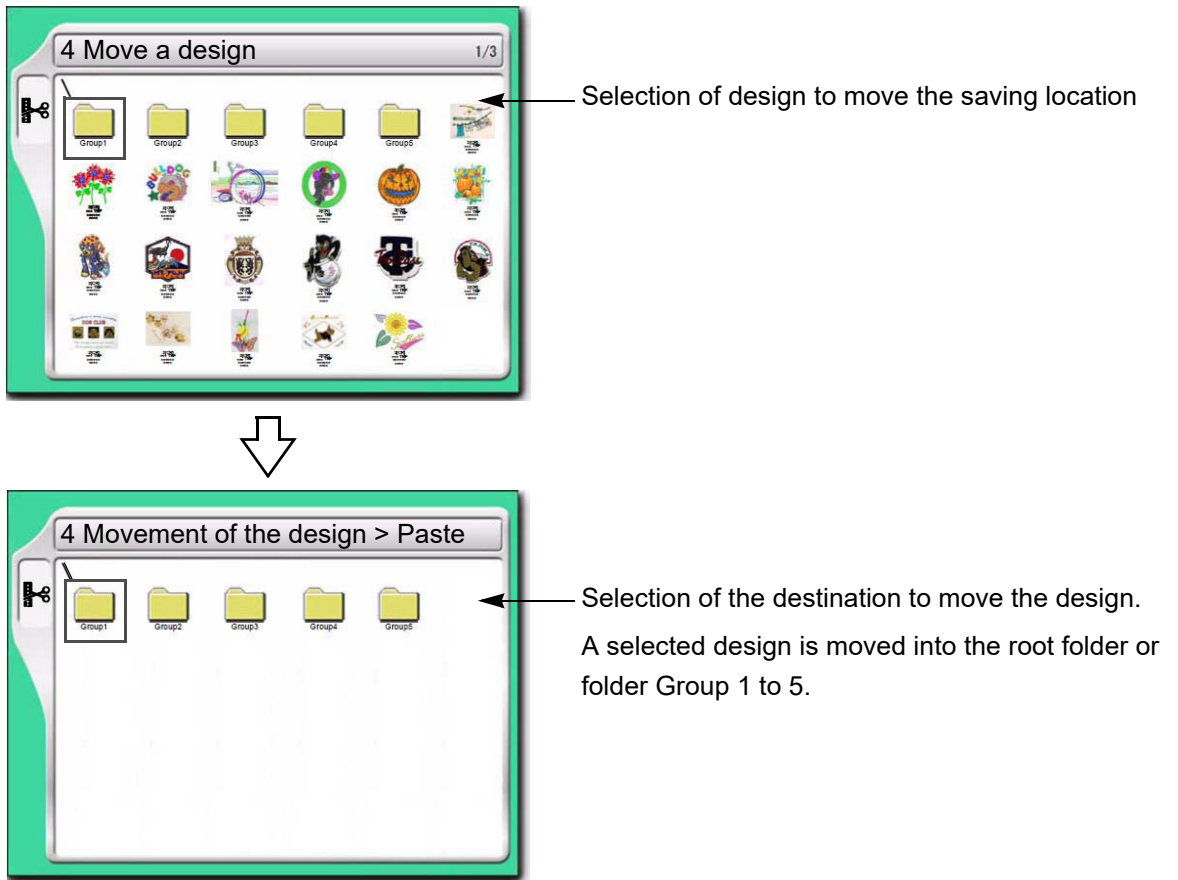

1-2-2. How to operate

The following is an example of moving a design to the folder (Group 3).

(1) To open screen

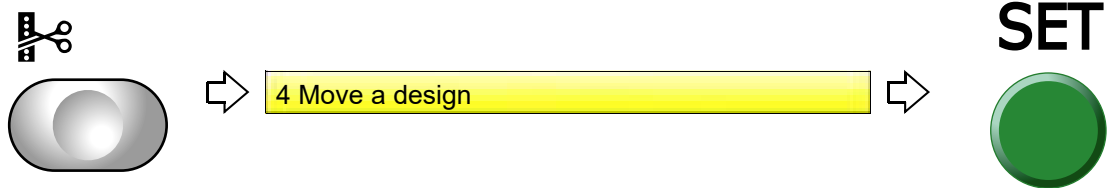

(2) To select a design

The operation differs depending on the storing place of the design.

(a) Design in folder



1
2
3
4
5
6
7
8
9
10
11
12

(b) Design on screen

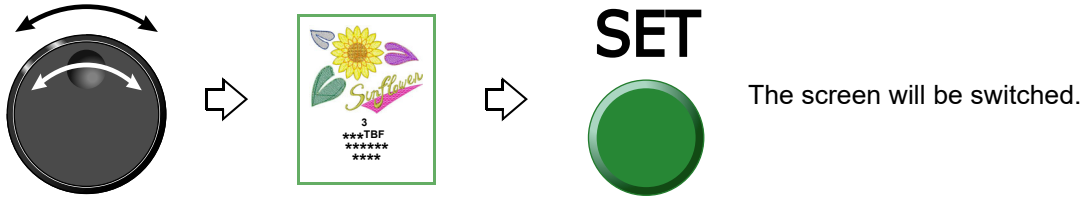

(3) To select destination to move and decide

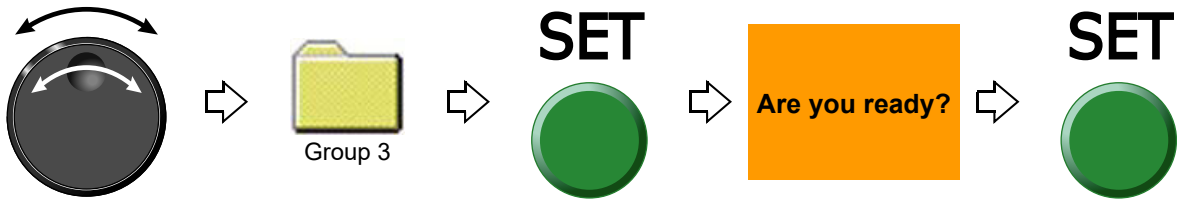

1-3. To copy a design (Copy a design)

1-3-1. Explanation on the screen

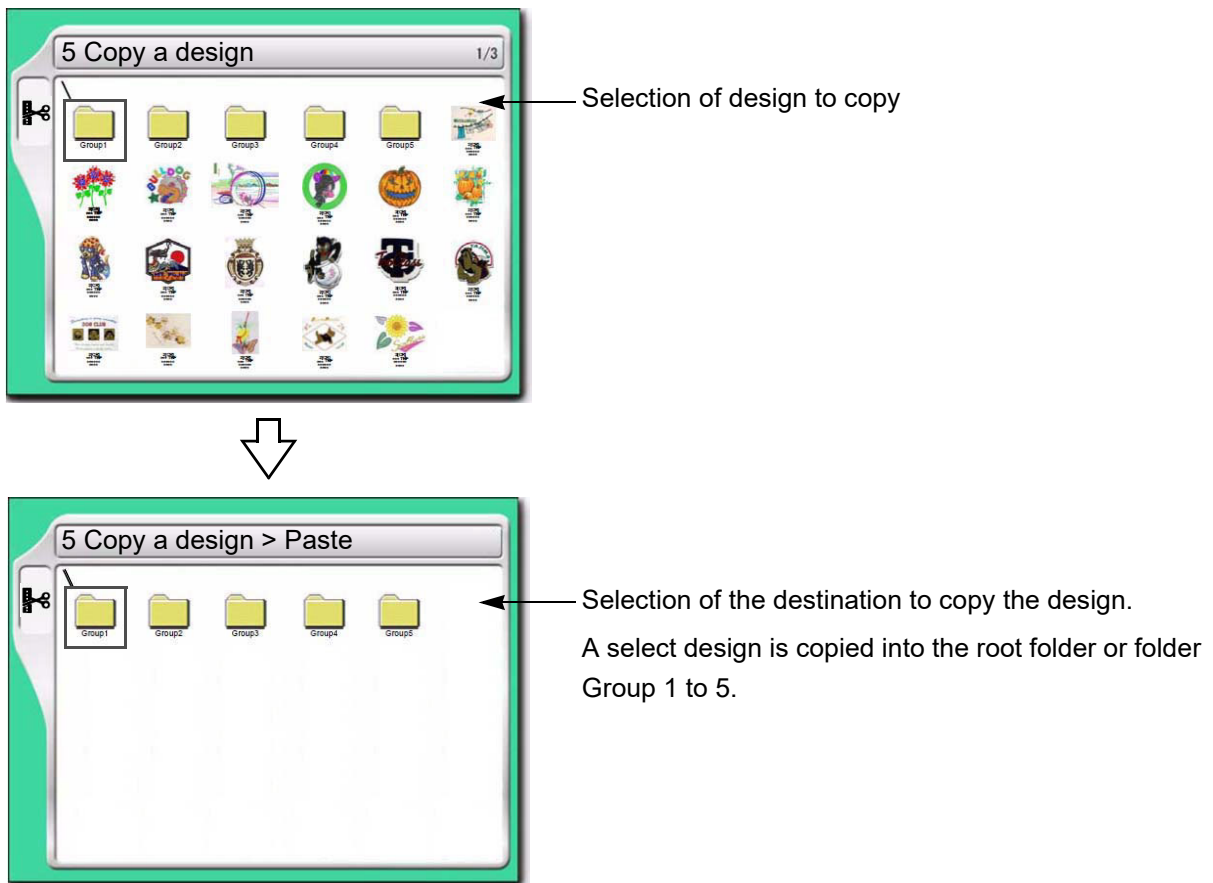

1-3-2. How to operate

The following is an example of copying a design and storing it in the folder (Group 3).

(1) To open screen

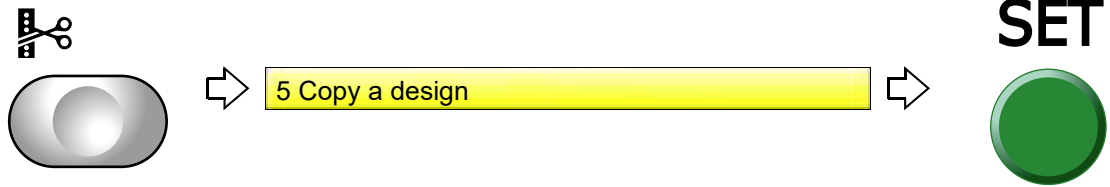

(2) To select a design

The operation differs depending on the storing place of the design.

(a) Design in folder



(b) Design on screen



(3) Select a destination to copy, and decide.

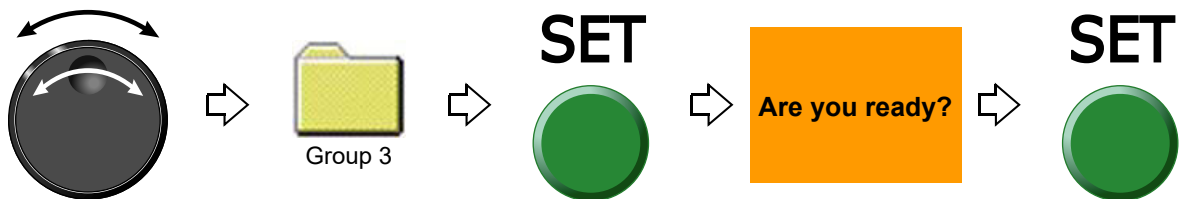

1
2
3
4
5
6
7
8
9
10
11
12

1-4. To change the file name of the design (Changing design name)

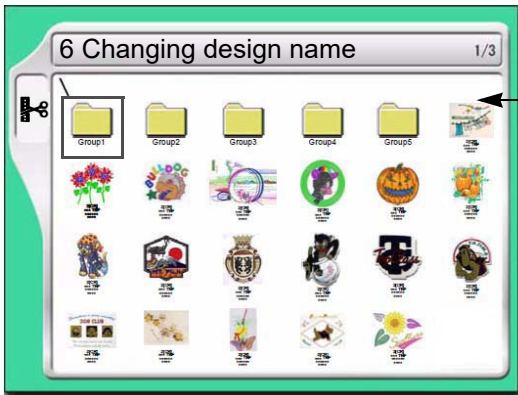

Selection of design to change the file name

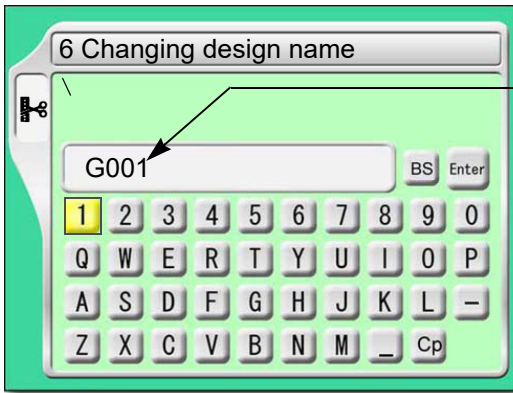

Change column of file name (up to 8 characters)
Delete and input letters.

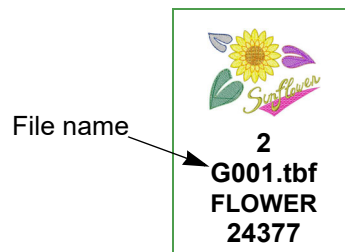

1-4-1. How to operate

The following is an example of changing the file name from "G001" to "A10".

(1) To open screen

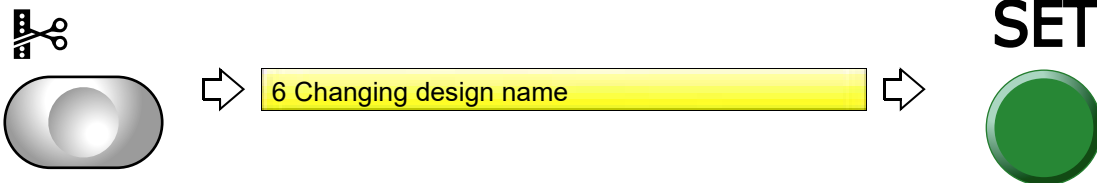

(2) To select a design

The operation differs depending on the storing place of the design.

(a) Design in folder



(b) Design on screen

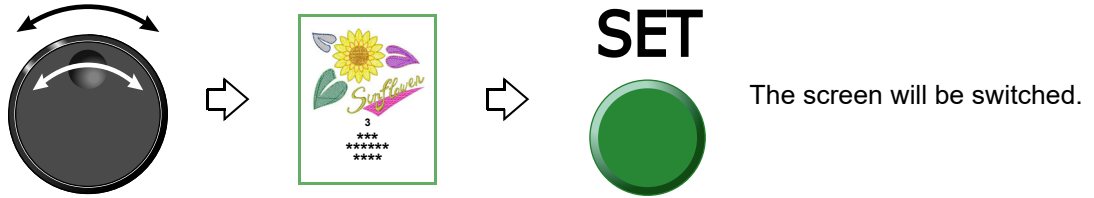

(3) To change file name

(a) To return the cursor to the top of the file name

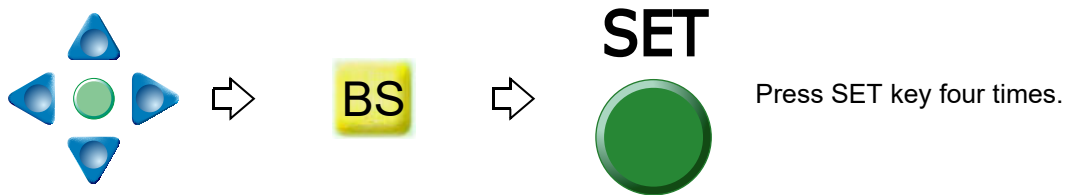

(b) To select "A"



(c) To select "1"



(d) To select "0"

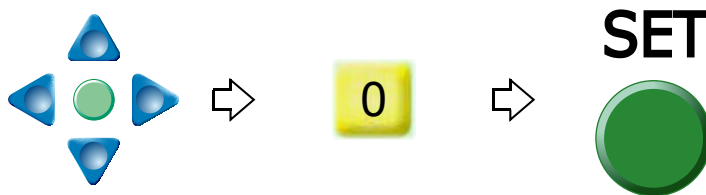

(e) To select "Enter" and decide

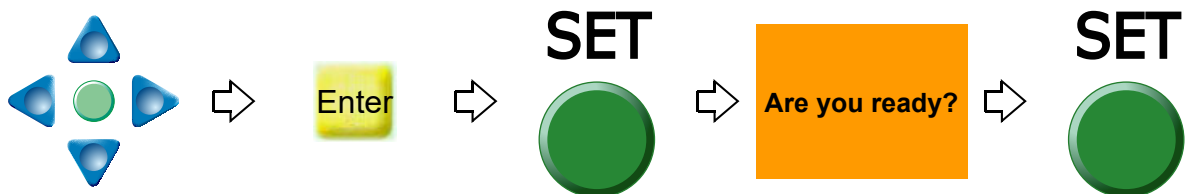

1
2
3
4
5
6
7
8
9
10
11
12

1-5. To change a folder name (Changing folder name)

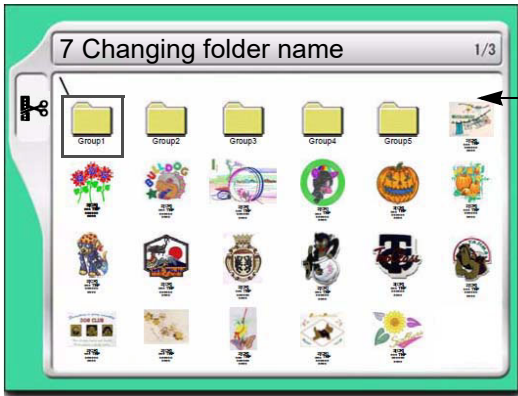

Selection of folder to change the name

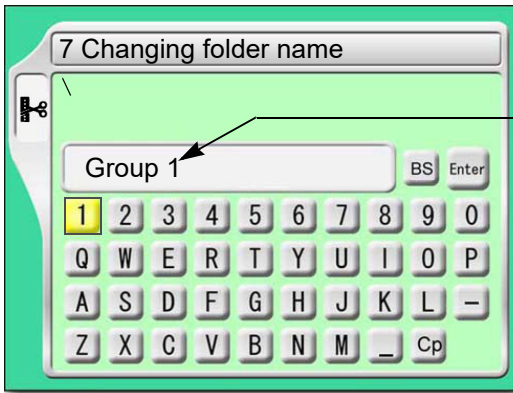

Change column of folder name (up to 8 characters)

Delete and input letters.

1-5-1. How to operate

The following is an example of changing the folder name from "Group 1" to "Design1".

(1) To open screen

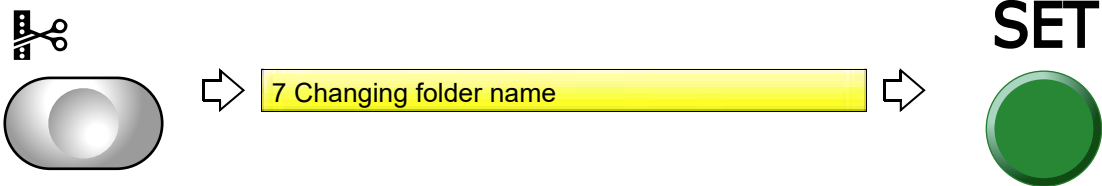

(2) To select a folder



(3) To change a folder name

(a) To return the cursor to the top of the folder name



(b) To select "D"



(c) To set to make small letters possible to be input



(d) To select "e"

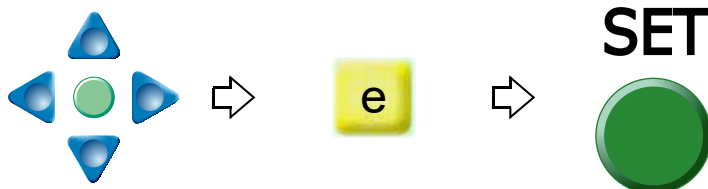

(e) To select "s"



(f) To select the remaining character (ign 1) similarly.

(g) To select "Enter" and decide

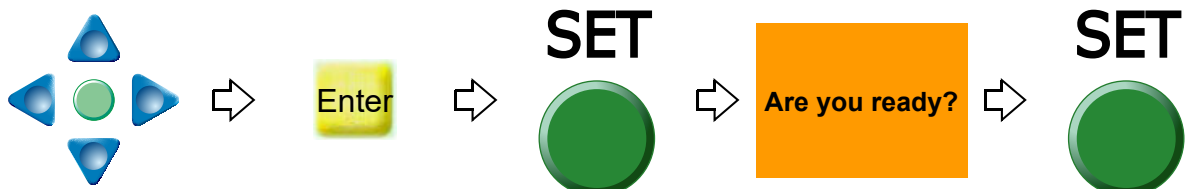

1
2
3
4
5
6
7
8
9
10
11
12

1-6. To sort a design (Design sort "in memory")

This function sorts designs in the machine memory by turns from the front. The folder will be displayed in advance of design.

1-6-1. Explanation on the screen

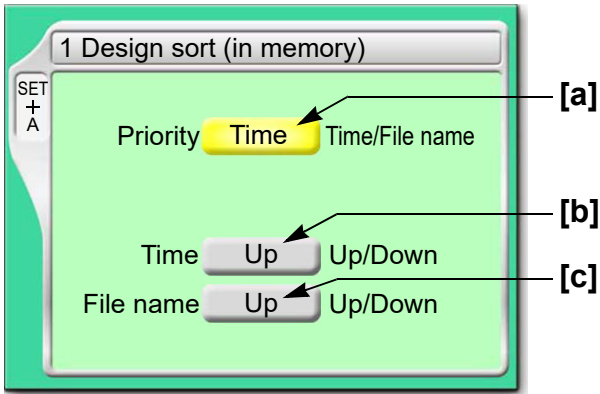

[a] Priority to sort

Time

It gives priority to updated time. When selecting "Time", perform the setting of the following [b].

File name

Give priority to the file name of the design. When selecting "File", perform the following setting [c].

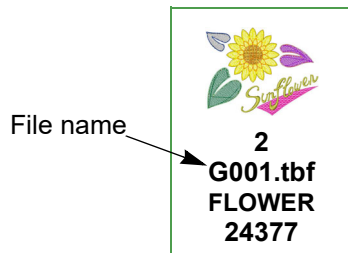

[b] Sorting method in "Time"

Up: Old → New

Down: New → Old

[c] Sorting method in "File Name"

Up: Digit/Symbol → ABC

Down: ABC → Digit/Symbol

1-6-2. How to operate

The following is an example of setting sort of the design giving the priority to "Time" and to "New → Old".

(1) Set to main screen.

(2) To press A key while pressing SET key, and press SET key further

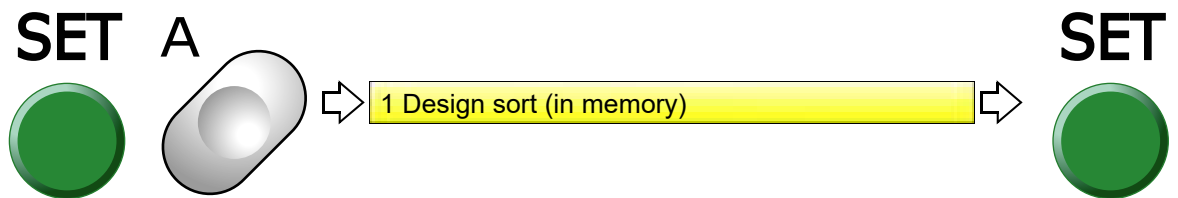

(3) To select priority to sort

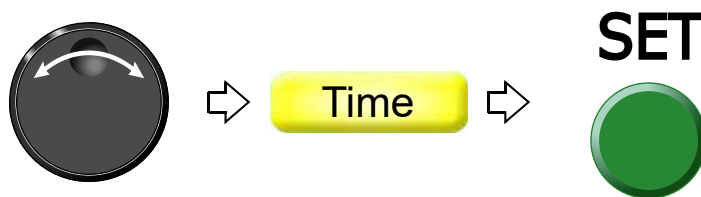

(4) To select sorting method

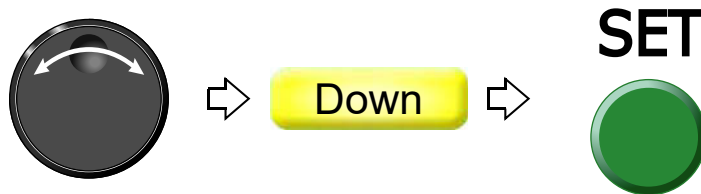

1
2
3
4
5
6
7
8
9
10
11
12

1-7. To store a design to a USB memory (USB "Save")

This operation requires input of the password.

1-7-1. Explanation on the screen

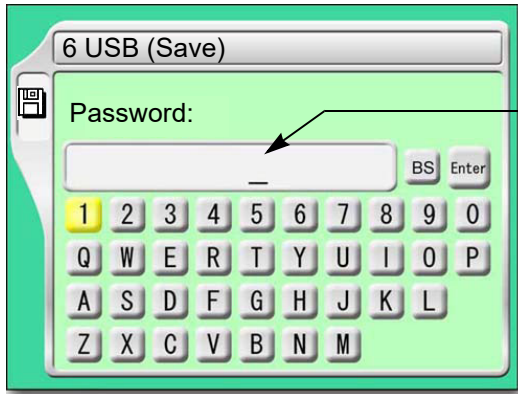

Inputting column of password

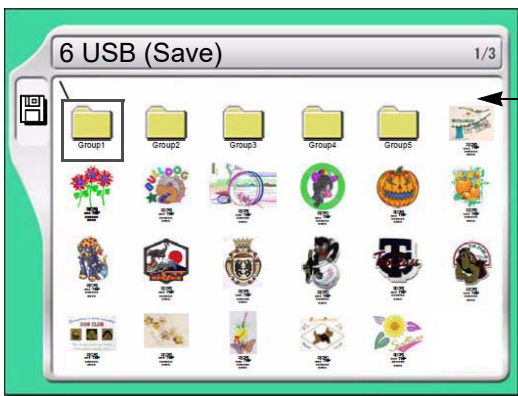

Selection of design to store into the USB memory

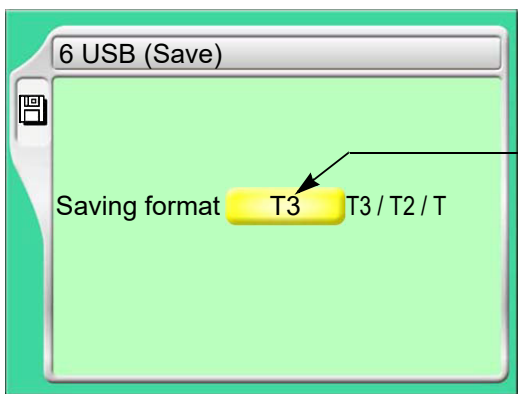

Saving format to USB memory
Usually, select "T3".

1-7-2. How to operate

The following is an example of saving designs into the USB memory.

(1) To set USB memory

(2) To open screen

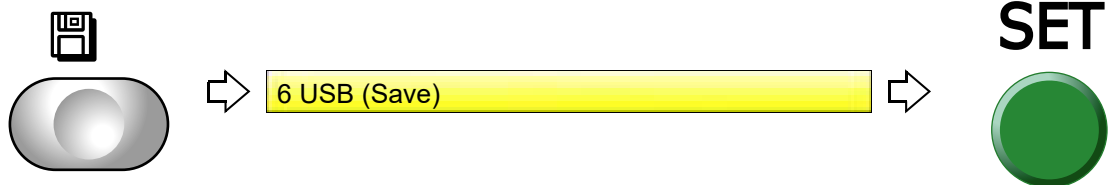

(3) To cancel the password

Regarding canceling method, refer to the detail page. (→p.153)

(4) To select a design

The operation differs depending on the storing place of the design.

(a) Design in folder



(b) Design on screen



(c) To select "Enter" and decide

When changing the file name, refer to the detail page. (→p.188)

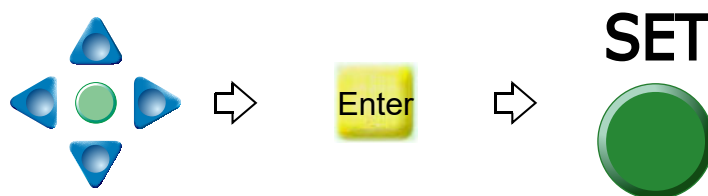

(5) To select saving format to USB memory and decide

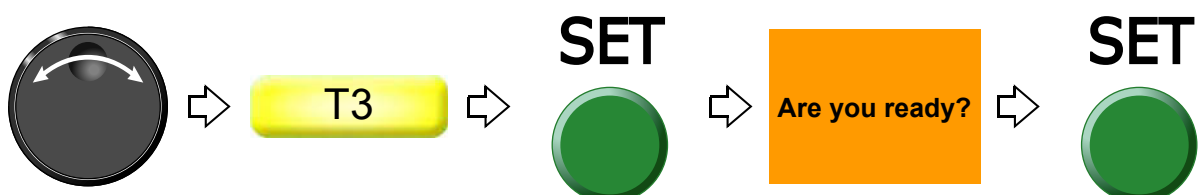

1
2
3
4
5
6
7
8
9
10
11
12

2. Design saved in USB memory

2-1. To delete a design (USB Delete)

2-1-1. Explanation on the screen

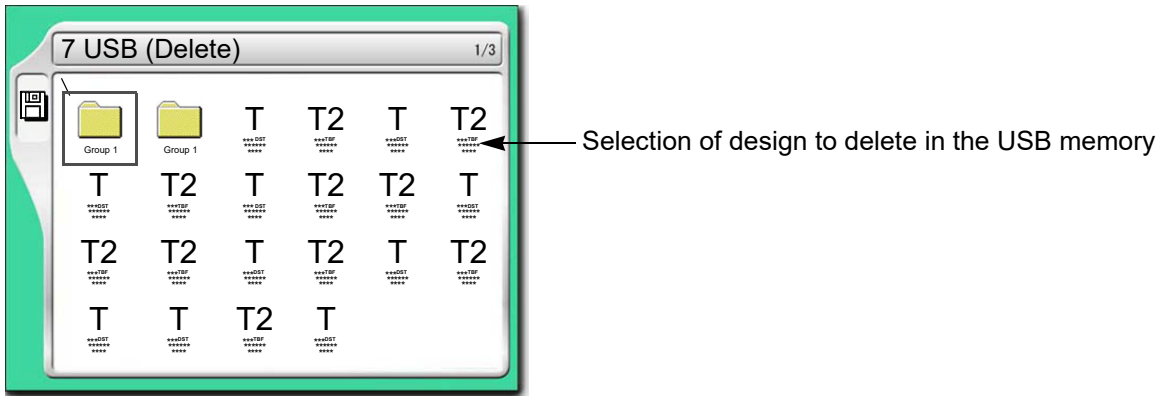

2-1-2. How to operate

The following is an example of deleting a design.

(1) To set USB memory

(2) To open screen

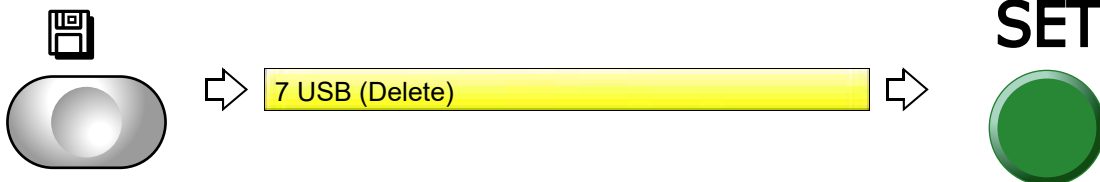

(3) To select a design

The operation differs depending on the storing place of the design.

(a) Design in folder



(b) Design on screen

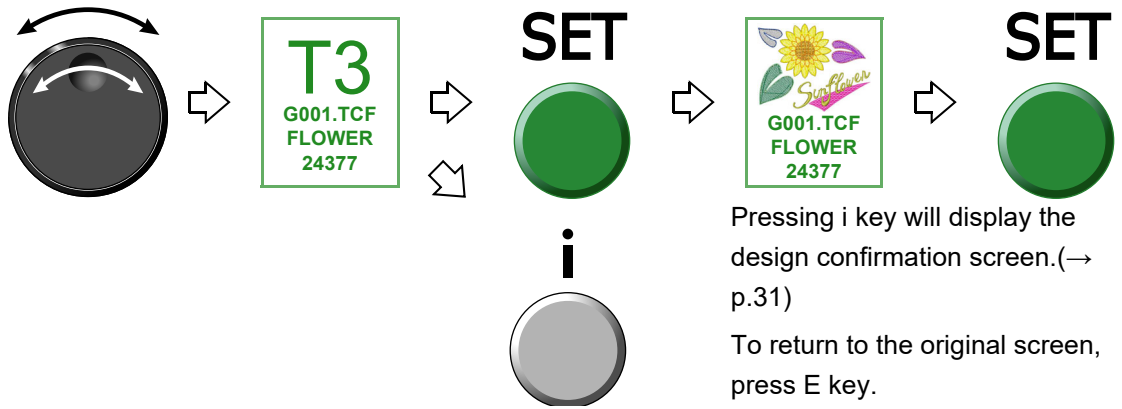

(4) To delete

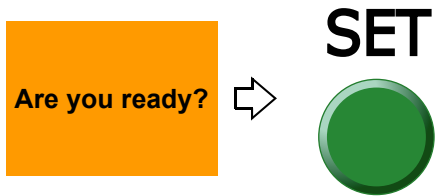

1
2
3
4
5
6
7
8
9
10
11
12

2-2. To sort a design (Design sort "USB")

This function sorts designs in the machine memory by turns from the front. The folder is displayed in advance of design.

2-2-1. Explanation on the screen

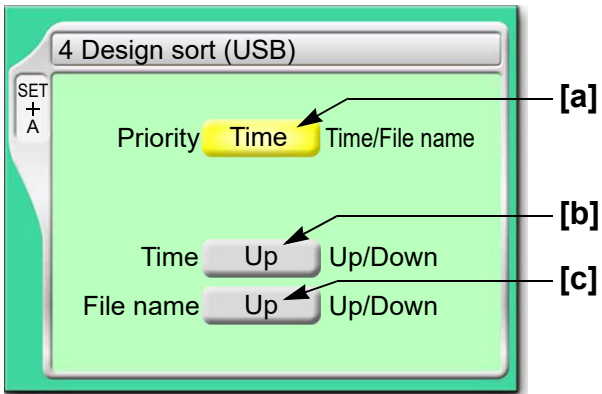

[a] Priority to sort

Time

It gives priority to updated time. When selecting "Time", perform the setting of the following [b].

File name

Give priority to the file name of the design. When selecting "File", perform the following setting [c].

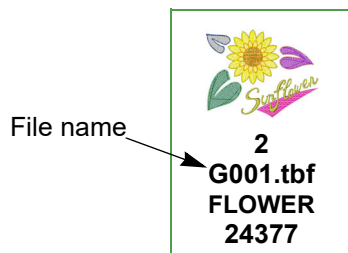

[b] Sorting method in "Time"

Up: Old → New

Down: New → Old

[c] Sorting method in "File Name"

Up: Digit/Symbol → ABC

Down: ABC → Digit/Symbol

2-2-2. How to operate

The following is an example of setting sort of the design giving the priority to "Time" and to "New → Old".

- (1) To set USB memory
- (2) Set to main screen.
- (3) To press A key while pressing SET key

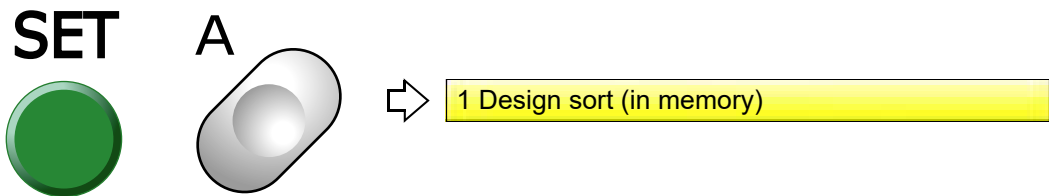

- (4) To press A key

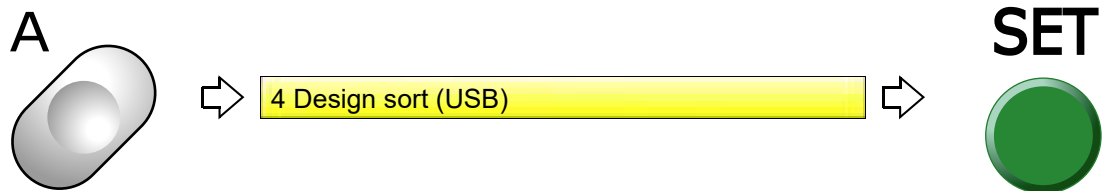

- (5) To select priority to sort



- (6) To select sorting method

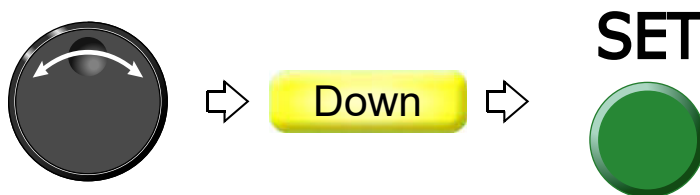

1
2
3
4
5
6
7
8
9
10
11
12

Chapter 9

Setting for optional device

1. To make optional device available for use.....	202
2. To set details of optional device.....	215
3. Functions concerning optional device.....	221

1

2

3

4

5

6

7

8

9

10

11

12

1. To make optional device available for use

Before using optional devices, be sure to check the setting condition for each device.

1-1. Sequin Device (common to IV and ESQ-C)

This is a setting for making sequin device available for use. For details of the device, refer to the separate manual "Sequin Device IV" or "ESQ-C".

This function is applied for TCMX-mixed type series.

1-1-1. Explanation on the screen

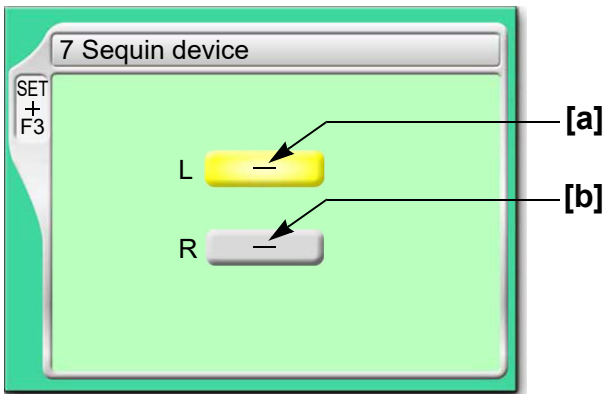

- [a]** Type of Sequin device equipped to left side
 - : Not to use the device
 - SQ: High speed Sequin device
 - SQ3: Sequin device III (Up/down-by-motor type)
 - SQ4: Sequin device IV (Up/down-by-air type)
 - Air compressor is required.
 - ESQ-C: ESQ-C
 - For details, read the separate volume "ESQ-C".
- [b]** Type of Sequin device equipped to the right side
 - The contents of settings are the same as [a].

1-1-2. How to operate

The following is an example of equipping ESQ-C to the left side.

- (1) Set to main screen.
- (2) To press F3 key while pressing SET

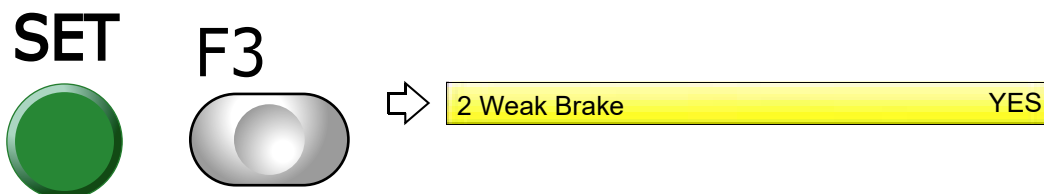

(3) To press F3 key

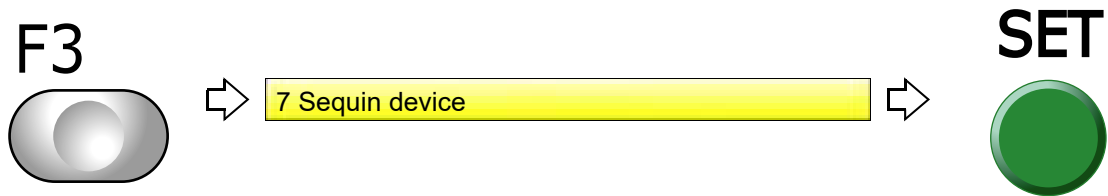

(4) To select type of sequin

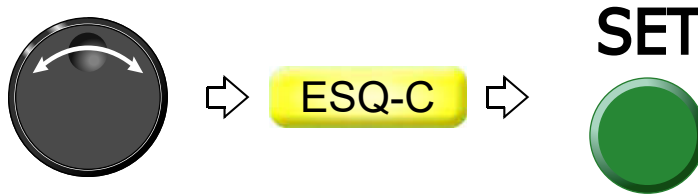

Proceed to the following operation continuously.

When "ESQ-C" is selected, proceed to "2-1. ESQ-C (FM head)"(→p.215).

When "SQ4" is selected, proceed to "2-2. Sequin Device IV (FM head)"(→p.218).

1-2. Seed Beads Device (FM head)

This is the setting to make Seed beads device available for use. For details of the device, refer to the separate manual "Seed Beads Device".

This function is applied for TCMX-mixed type series.

1-2-1. Explanation on the screen

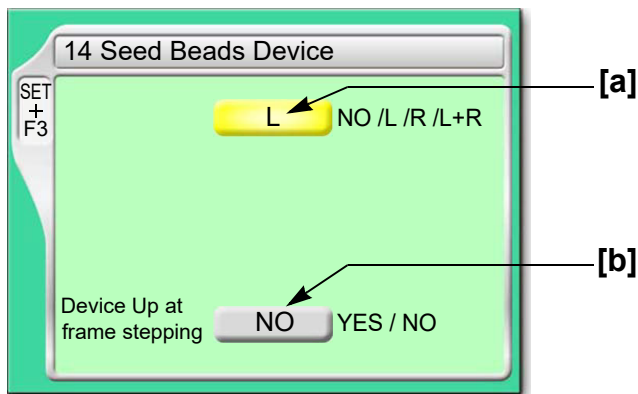

[a] Type of device

L: Equipped to left side

R: Equipped to right side

L+R: Equipped to left and right side

NO: Not to equip

[b] Moving up of device at frame stepping

YES: To perform

NO: Not to perform

! CAUTION

! Selecting "NO" will increase manufacturing efficiency. However, the device could interfere with the frame resulting in its breakage depending on design or frame type to use.

1-2-2. How to operate

The following is an example of equipping the device to the left side and setting "To move up" the device at frame stepping.

(1) Set to main screen.

(2) To press F3 key while pressing SET

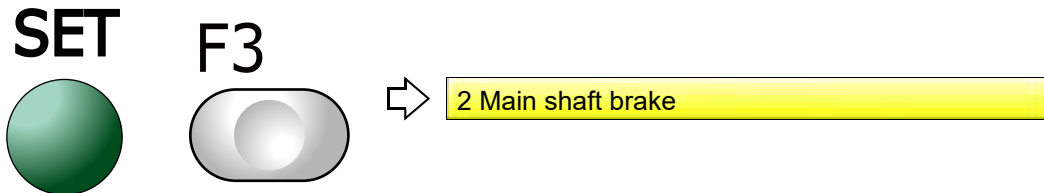

(3) To press F3 key

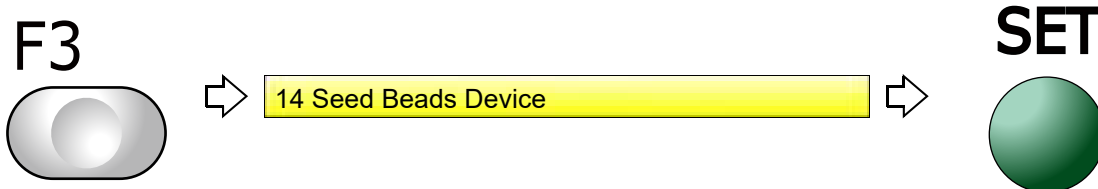

(4) To equip to left side

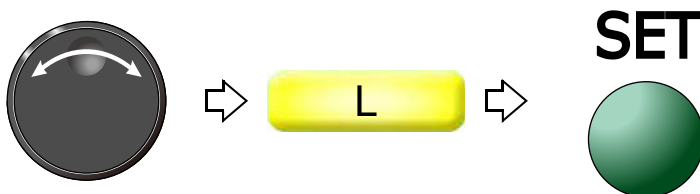

(5) To move up device at frame stepping

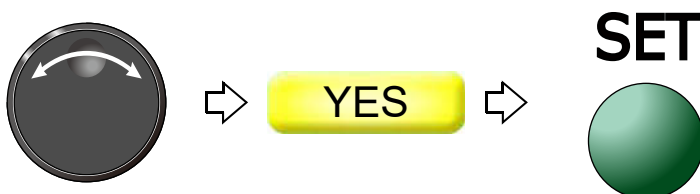

Proceed to the following operation continuously.

"To make the air compressor available for use (Air Pressure Sensor)"(→p.221).

1-3. Automatic Lubrication System (FM head)

This setting makes Automatic lubrication system available for use. For details of the device, refer to the separate manual "Automatic lubrication system".

This function is applied for TCMX-mixed type series.

1-3-1. Explanation on the screen

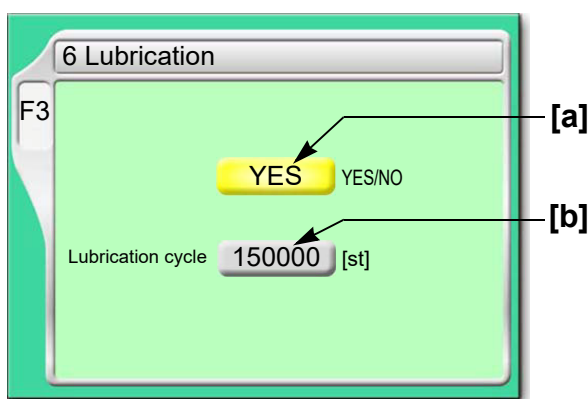

[a] Use of the device

YES: To use

NO: Not to use

[b] Lubricating cycle to inside of the arm

When counting reaches the number of set stitches, the machine will lubricate to the inside of the arm (recommended value: 150000).

1-3-2. How to operate

The following is an example of setting the lubricating cycle to the inside of the arm to "150000".

(1) To open screen

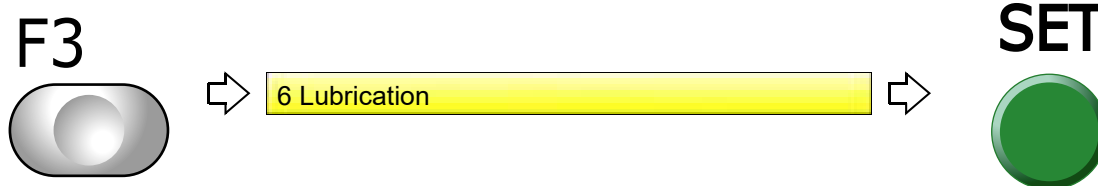

(2) To use the device

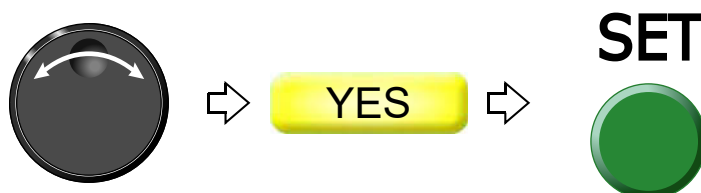

(3) To select lubricating cycle to inside of the arm



1-4. Network

This is the setting to make the network available for use by LAN connection.

1-4-1. Explanation on the screen

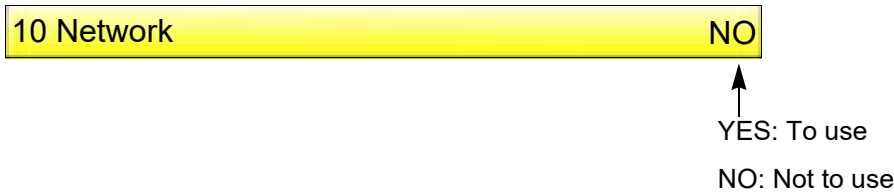

1-4-2. How to operate

The following is an example of connecting to DG/ML by Pulse or Autograph via Network.

(1) Set to main screen.

(2) To press F3 key while pressing SET

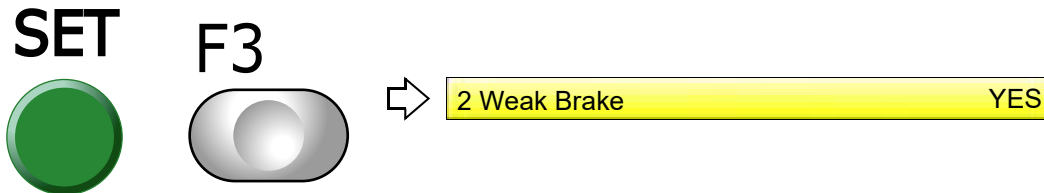

(3) To press F3 key

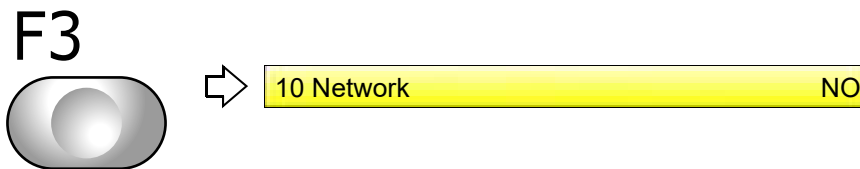

(4) To connect to DG/ML by Pulse or Autograph via Network

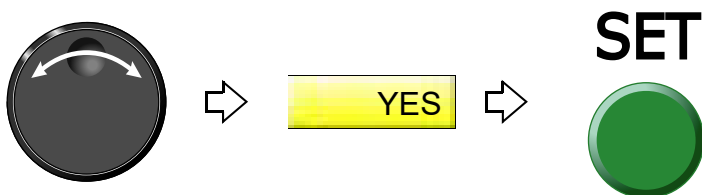

1-5. Lochrose embroidery device (FM head)

This setting makes Lochrose embroidery device available for use. For details of the device, refer to the separate manual "Lochrose embroidery device".

This function is applied for TCMX-mixed type series.

1-5-1. Explanation on the screen

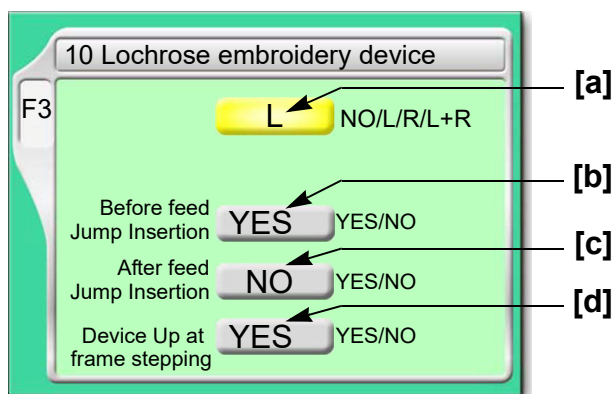

[a] Type of device

L: Equipped to left side

R: Equipped to right side

L+R: Equipped to left and right side

NO: Not to equip

[b] Insert jump before feeding material

Setting whether or not to insert a non-data jump code automatically before feeding out beads

YES: To insert

When beads can not be sewn effectually, select "YES". However, productivity will be decreased.

NO: Not to insert

[c] Insert jump after feeding material

Setting whether or not to insert a non-data jump code automatically after feeding out beads

YES: To insert

When you desire to tighten stitching tension of beads, select "YES". However, productivity will be decreased.

NO: Not to insert

[d] Moving up of device at frame stepping

YES: To perform

NO: Not to perform

! CAUTION

! Selecting "NO" will increase manufacturing efficiency. However, the device could interfere with the frame resulting in its breakage depending on design or frame type to use.

1-5-2. How to operate

The following is an example that the device is equipped to the left side and Jump is set to "To insert" before feeding out beads.

(1) To open screen

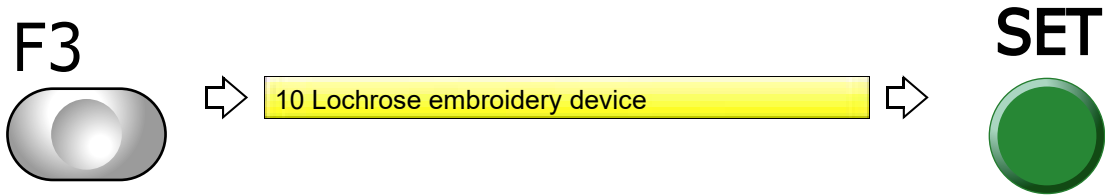

(2) To equip to left side

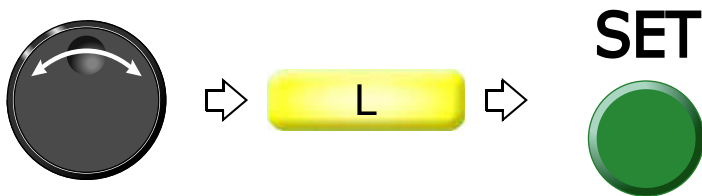

(3) To insert non-data jump code automatically



Proceed to "To make the air compressor available for use (Air Pressure Sensor)" continuously.(→p.221)

1-6. Cording device (FM head)

This is a setting for making coding device (KB-2M) available for use. For details of the device, refer to the separate manual "KB-2M (L&R)".

This function is applied for TCMX-mixed type series.

1-6-1. Explanation on the screen

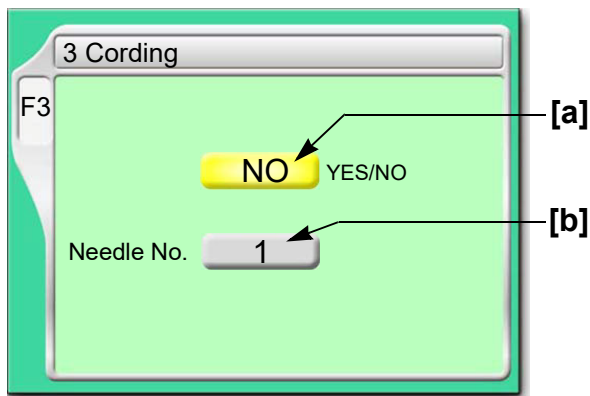

[a] Use of the device

YES: To use

NO: Not to use

[b] Equipped needle bar position

1(st needle): Equipped to the right side

12 (th needle): Equipped to left side (in case of 12-needle machine)

The last needle will be displayed.

1-6-2. How to operate

The following is an example of equipping Cording device to the left side.

(1) To open screen

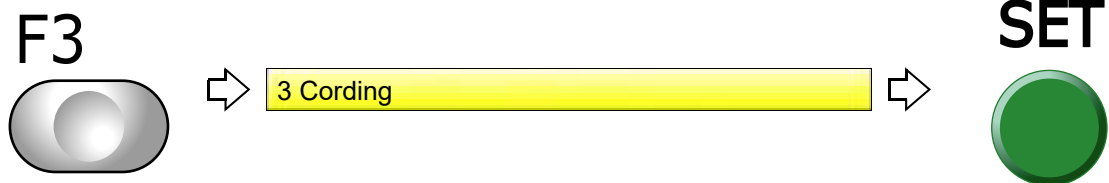

(2) To use cording device



(3) To select the needle bar No.

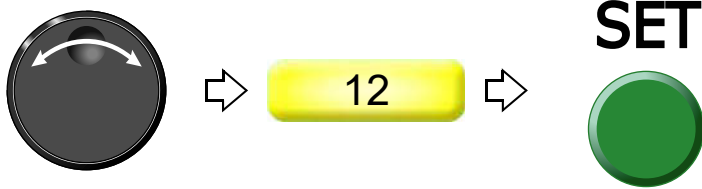

1-7. Boring device II (FM head)

This is a setting for making Boring device available for use. For details of the device, refer to the separate manual "Boring device II".

This function is applied for TCMX-mixed type series.

1-7-1. Explanation on the screen

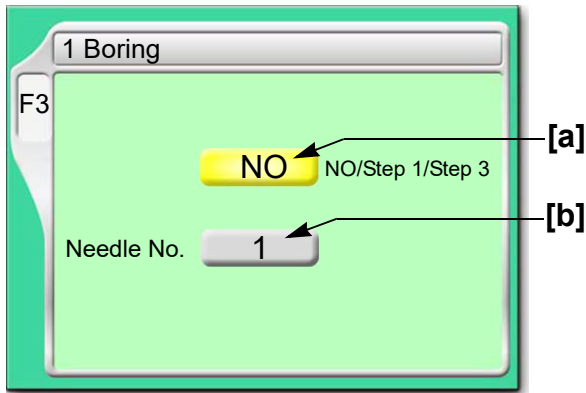

[a] Setting of Boring

Value	Device	Frame Travel[*1]	Scale up/down, rotation, reversion of design
NO	Not to use	-	-
Step 1[*2]	To use	Not to perform	Unable
Step 3[*3]		To perform	Able

[*1] When switching to boring, the frame will move by 12 mm in vertical direction.

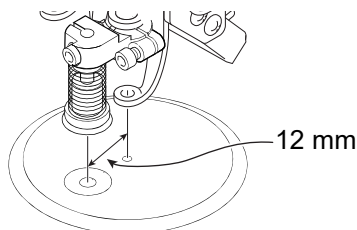

[*2] Select if there is frame travel data in the design.

[*3] Select if there is not frame travel data in the design.

[b] Needle bar No. equipped with device

1-7-2. How to operate

The following is an example that Boring device is set to "Step 3" and equipped to the needle bar No. "4".

(1) To open screen

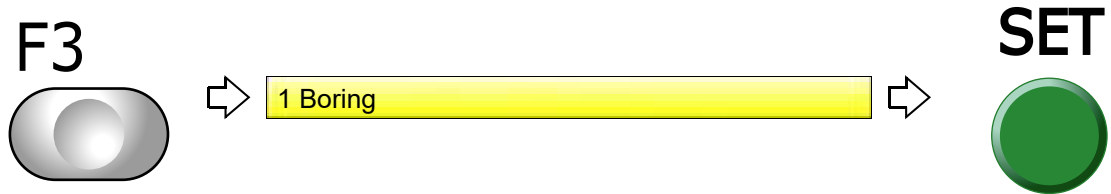

(2) To select Boring step



(3) To select the needle bar No.

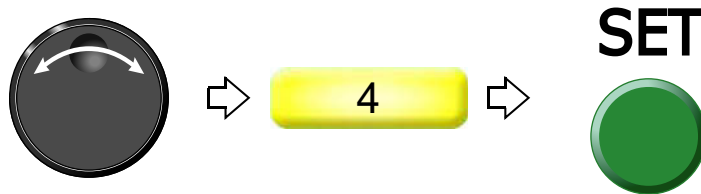

1
2
3
4
5
6
7
8
9
10
11
12

1-8. Bobbin changer (FM head)

This is a setting for making Bobbin changer (UBC II) available for use. For details of the device, refer to the separate manual "UBC II".

This function is applied for TCMX-mixed type series.

1-8-1. Explanation on the screen



1-8-2. How to operate

The following is an example of setting Bobbin changer to "To use".

(1) To open screen

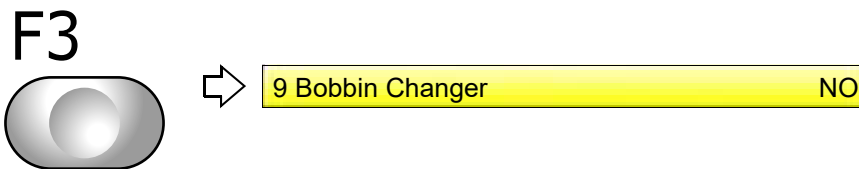

(2) To use Bobbin changer

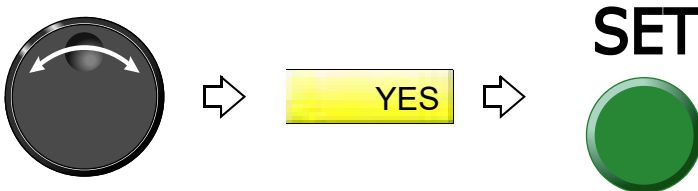

1-9. MT-1 (Coiling) (CM head)

This setting makes MT-1 available for use. For details of the device, refer to the separate manual of "MT-1". This function is effective only when "M-axis" is set to YES. (SET+F4: 5 Machine Information)

1-9-1. Explanation on the screen

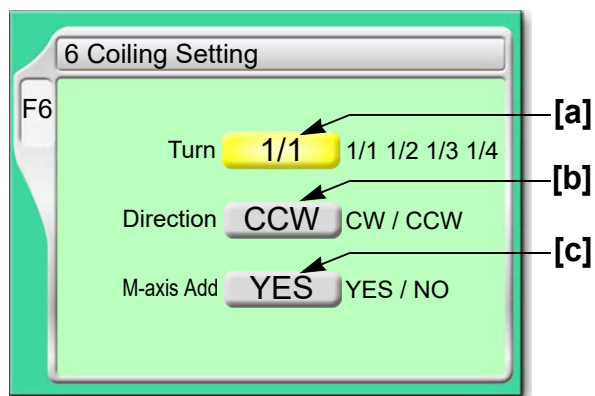

[a] Turning amount of bobbin against one stitch

- 1/1: Turning by 360°
- 1/2: Turning by 180°
- 1/3: Turning by 120°
- 1/4: Turning by 90°

[b] Turning direction of bobbin

CW: Clockwise, CCW: Counterclockwise

[c] To optimize bobbin turning against frame travel direction

Select YES.

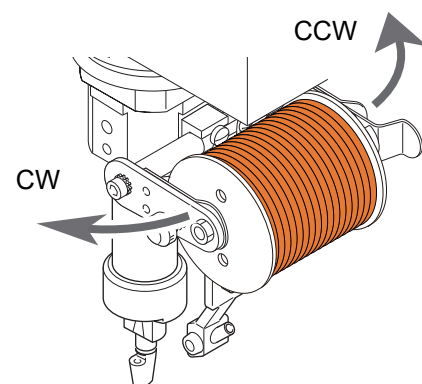

1-9-2. How to operate

The following is an example of setting turn volume to "1/3".

(1) To open screen

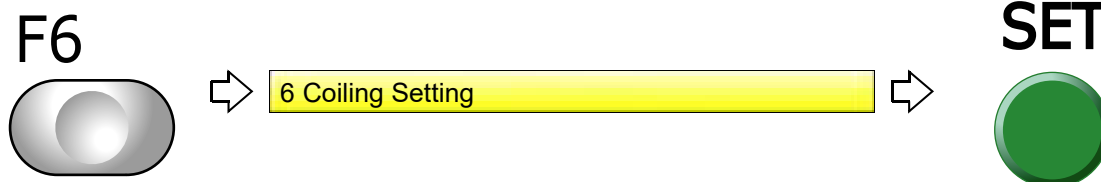

(2) To select turn (turn volume)

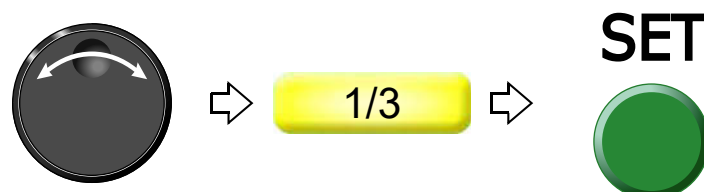

1-10. KT-1 (Taping) (CM head)

This setting makes Taping device (KT-1) available for use. For details of the device, refer to the separate manual of "K-2, KT-1".

1-10-1. Explanation on the screen



1-10-2. How to operate

The following is an example of setting KT-1 to "To use".

(1) To open screen



(2) To use KT-1

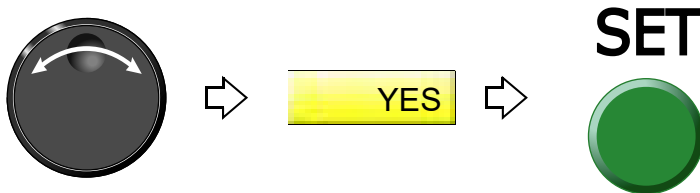

2. To set details of optional device

2-1. ESQ-C (FM head)

The detail of the device will be set.

This function is applied for TCMX-mixed type series.

2-1-1. Explanation on the screen

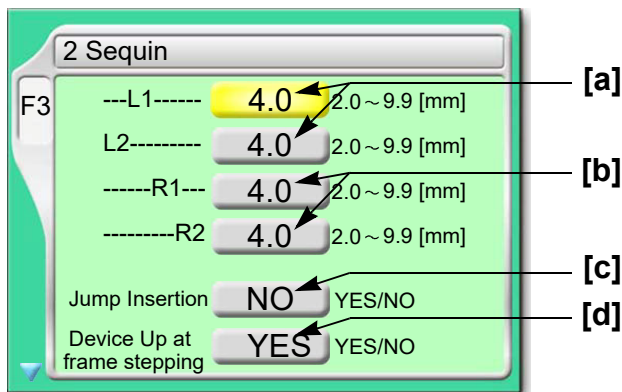

[a] Feed amount of sequin chips for each device L1 and L2 at the left side (refer to the right figure)

Select a value that adds about 1.0 to an external diameter of chip as a rough standard.

[b] Feed amount of sequin chips for each device R1 and R2 at the right side (refer to the right figure)

Select a value that adds about 1.0 to an external diameter of chip as a rough standard.

[c] Insertion of jump data when a sequin chip is sewn on

Select "YES" when sequin chips are not sewn effectually. However, productivity will be decreased.

YES: To perform

NO: Not to perform

[d] Moving up of device at frame stepping

YES: To perform

NO: Not to perform

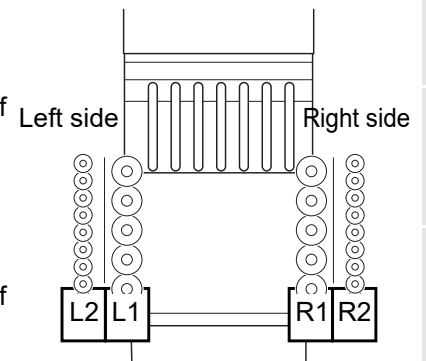

CAUTION

 Selecting "NO" will increase manufacturing efficiency. However, the device could interfere with the frame resulting in its breakage depending on design or frame type to use.

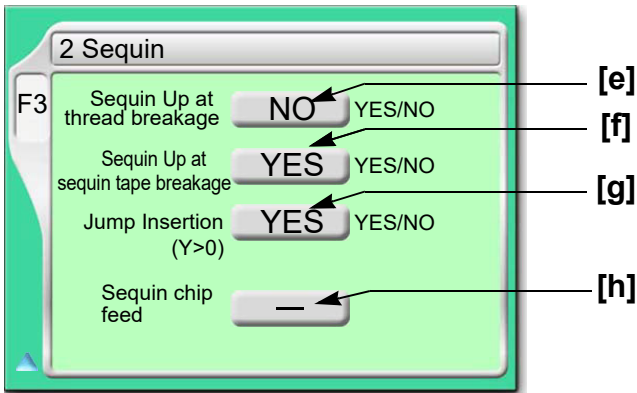

[e] Moving up of device at thread breakage

YES: To perform
NO: Not to perform

[f] Moving up of device when sequin chip runs out

YES: To perform
NO: Not to perform

[g] This setting prevents upper thread breakage by interference with device.

YES: To perform
NO: Not to perform

[h] Feed out sequin tip one by one by manual operation.(→p.217)

The feed amount is the value selected at [a] or [b] described above.
L: Left device
R: Right device

2-1-2. How to operate

This is an example of setting in the following conditions.

Feed amount of sequin chips of device (L1) at left side: 4.0

Insertion of jump data: To perform

Moving up of device at frame stepping: To perform

(1) To open screen

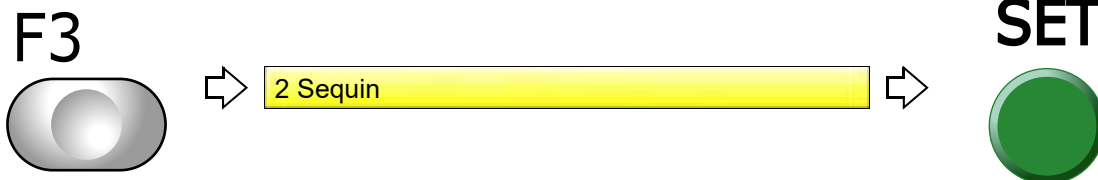

(2) To select feed amount of sequin chips of device (L1) at the left side



(3) To insert jump data

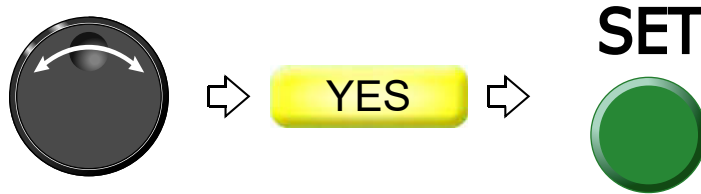

(4) To move up device at frame stepping



2-1-3. How to operate

⚠ CAUTION

⚠ When performing this operation, do not put your hands etc. near the needle or on the machine table. You could be injured by up/down of the device or moving right and left of the needle bar case.

The following is the example of feeding out sequin chips of the right side ESQ-C one by one.

(1) Set the tension base switch to "Middle" position. (It should not be suspended head.)

(2) To open screen

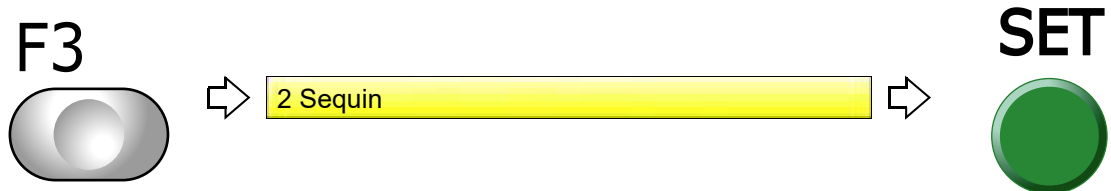

(3) To move the cursor to "Sequin chip feed"



(4) To select R (Right-side ESQ-C)

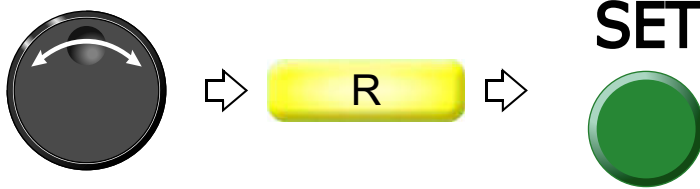

Pressing SET will perform color change to the sequin needle.

(5) To feed sequin chips

Every time raising the tension base switch will feed out sequin chips one by one.

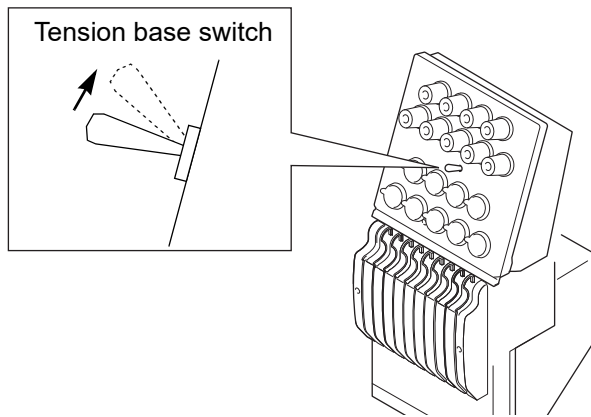

2-2. Sequin Device IV (FM head)

The detail of the device will be set.

This function is applied for TCMX-mixed type series.

2-2-1. Explanation on the screen

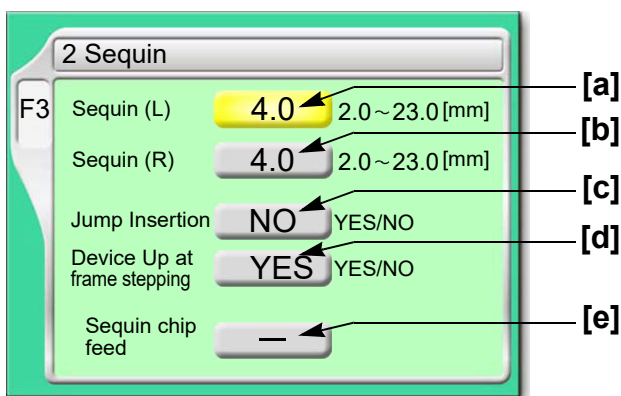

[a] Feed amount of sequin chips of device at left side

Select a value that adds about 1.0 to an external diameter of chip as a rough standard.

[b] Feed amount of sequin chips of the device at the right side

Select a value that adds about 1.0 to an external diameter of chip as a rough standard.

[c] Insertion of jump data when a sequin chip is sewn on

Select "YES" when sequin chips are not sewn effectually. However, productivity will be decreased.

YES: To perform

NO: Not to perform

[d] Moving up of device at frame stepping

YES: To perform

NO: Not to perform

! CAUTION

! Selecting "NO" will increase manufacturing efficiency. However, the device could interfere with the frame resulting in its breakage depending on design or frame type to use.

[e] Feed out the sequin chip one by one manually.(→p.217)

The feed amount is the value selected at [a] or [b] described above.

L: Left device

R: Right device

2-2-2. How to operate

This is an example of setting in the following conditions.

Feed amount of sequin chips of device at left side: 4.0

Insertion of jump data: To perform

Moving up of device at frame stepping: To perform

(1) To open screen

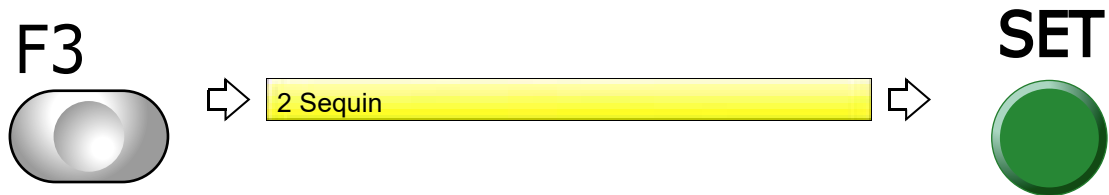

(2) To select feed amount of sequin chips of device at left side

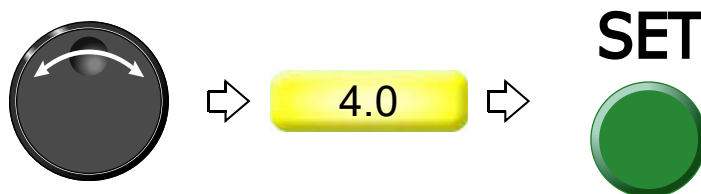

(3) To insert jump data



(4) To move up device at frame stepping



Proceed to "To make the air compressor available for use (Air Pressure Sensor)" continuously.
(→p.221)

3. Functions concerning optional device

3-1. To make the air compressor available for use (Air Pressure Sensor)

Set this function when the following optional devices are equipped.

Sequin device IV

Lochrose embroidery device

3-1-1. Explanation on the screen

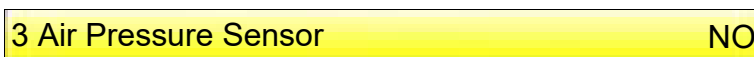

↑
YES: To use air compressor
NO: Not to use

3-1-2. How to operate

The following is the example of making Air compressor available for use.

(1) Set to main screen.

(2) To press F3 key while pressing SET

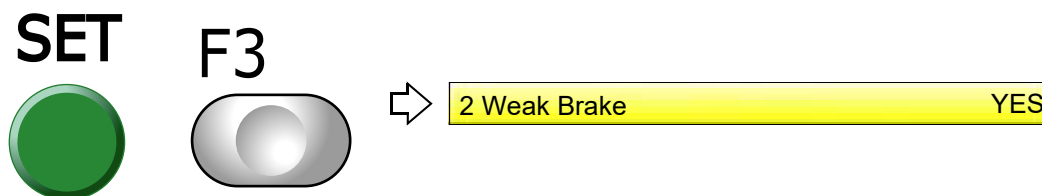

(3) To press F3 key

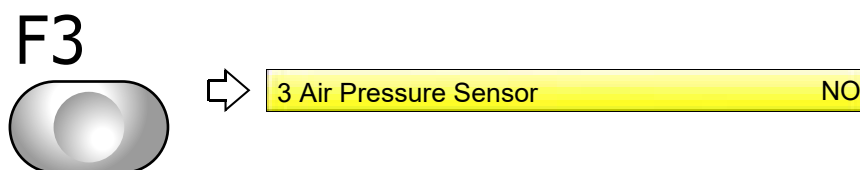

(4) To use the air compressor



1
2
3
4
5
6
7
8
9
10
11
12

3-2. To reverse the 1st color and the 2nd color in ESQ-C
(Data conversion for sequin output)

This is the setting not for replacing by removing sequin but for reversing sequin on the design data all at once when you desire to replace sequin of the device L1 and L2 (the right figure). This function is effective only for the step selected with sequin needle against step of sewing sequin.

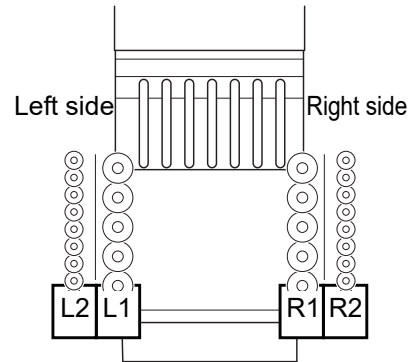

3-2-1. Explanation on the screen

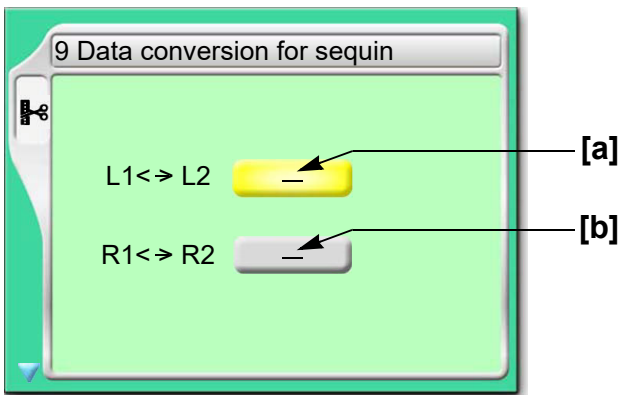

[a] The device L1 (1st color) and L2 (2nd color) at the left side will be replaced each other.

Thus, "Sequin_O" in the design data will be replaced with "Sequin_O_2" or vice versa.

Sequin_O (Sequin output): 1st color

Sequin_O_2 (Sequin output 2): 2nd color

[b] The device R1 (1st color) and R2 (2nd color) in the right side will be replaced each other.

3-2-2. How to operate

CAUTION

 The original design will be overwritten after editing. Back up design data as necessary.

The following is an example of reversing L1 and L2 in the device at left.

(1) To open screen

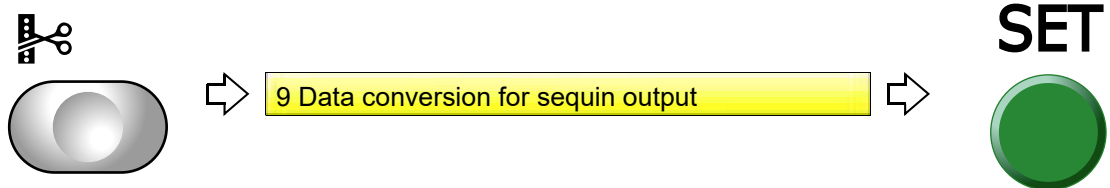

(2) To select a design



(3) To reverse

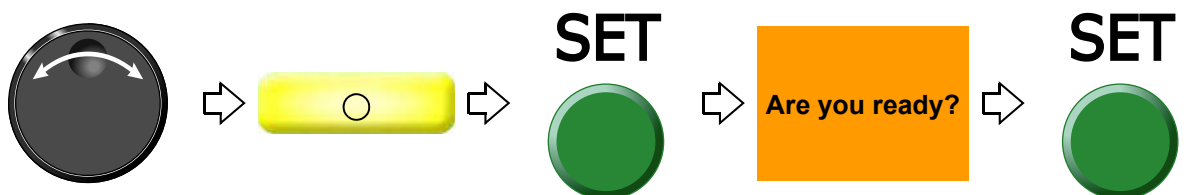

1
2
3
4
5
6
7
8
9
10
11
12

3-3. To change color by using DST design in ESQ-C (Auto Stitch Type Selection)

This setting enable color change on DST design (corresponding only to sequin code Sequin_O), that is originally used for single color, by using ESQ-C (corresponding to sequin code Sequin_O and Sequin_O_2). After inputting data of DST design, sequin code (Sequin_O) will be allocated to "1" in the right figure.

It is possible to switch "1" and "2" in step unit by this function.

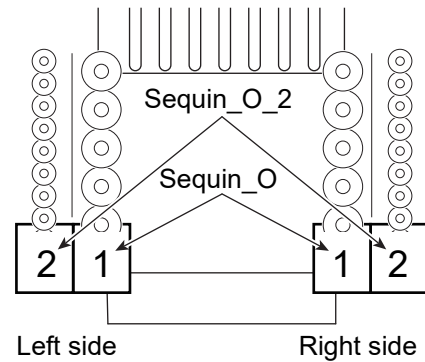

3-3-1. Explanation on the screen

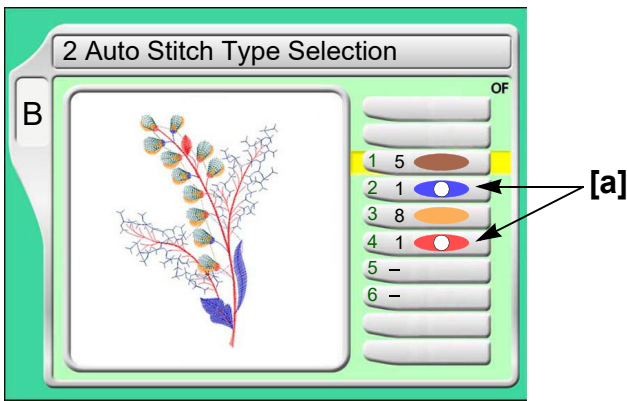

[a] Setting example of color change

Left side

In case of sewing by left side device "1"

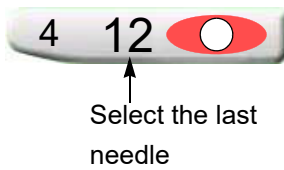

Left side

In case of sewing by left side device "2"

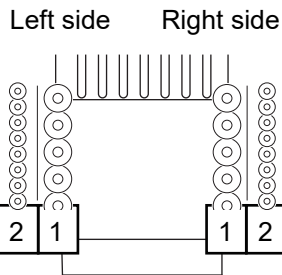

Right side

In case of sewing by left side device "1"

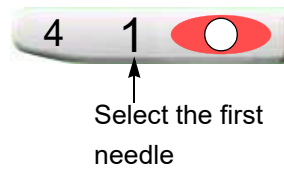

Right side

In case of sewing by left side device "2"



When saving data after change to the USB memory, display of "Needle Selection" on the operation panel will be switched as shown below figure. At the same time, the design data (the machine memory) will be also edited automatically, and sequin code in the design will switch from "Sequin_O" to "Sequin_O_2".



3-3-2. How to operate

The following is an example of sewing by left device "2" in step 2.

(1) To open screen

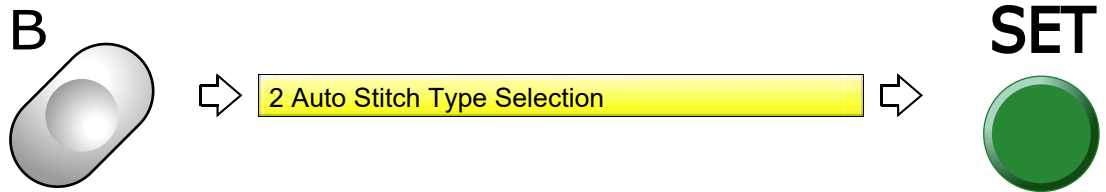

(2) To select Step 2

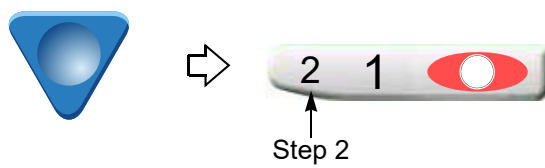

(3) To select device (last needle) at left side

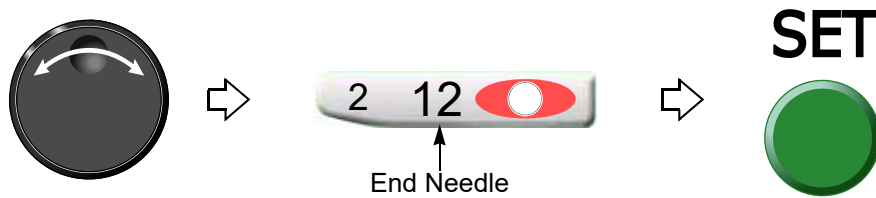

(4) To select device "2" (black dot)

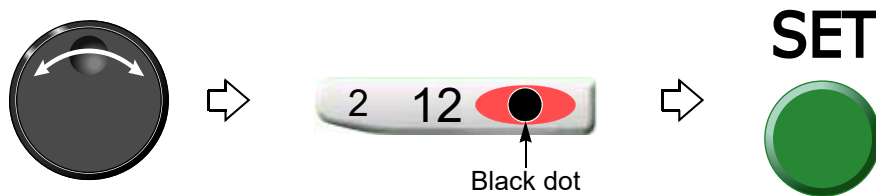

1
2
3
4
5
6
7
8
9
10
11
12

3-4. Lochrose counter

Display remaining number of beads for each head.

3-4-1. Explanation on the screen

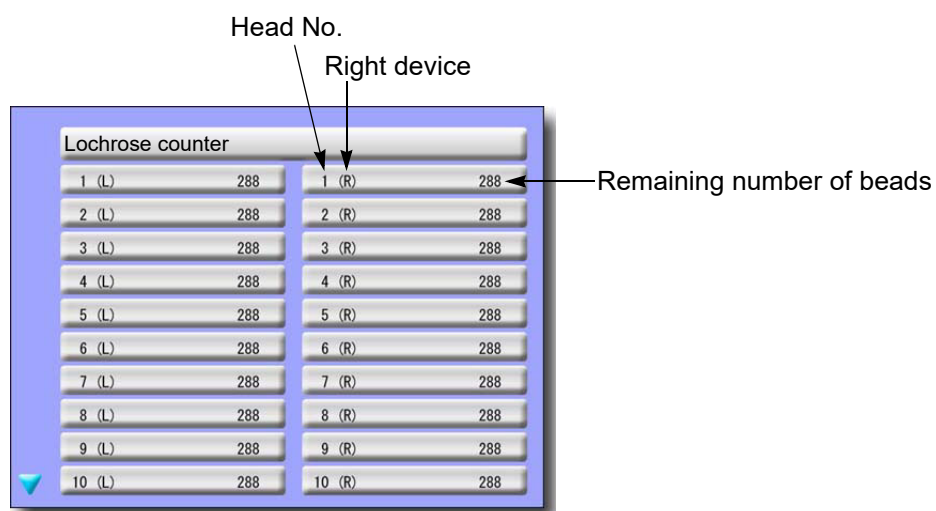

3-4-2. How to operate

Press i key until the screen shown above will be displayed.

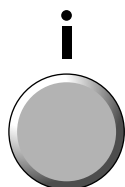

Chapter 10

Countermeasure when some trouble occurs in the machine

1. Countermeasure when the machine stopped228
2. Trouble examples and Corrective actions (CM head)236
3. Trouble examples and Corrective actions (FM head).....240

1

2

3

4

5

6

7

8

9

10

11

12

1. Countermeasure when the machine stopped

When the machine stops during embroidery, a code No. indicating stop factor will be displayed on the screen (the illustration below is an example).

Restoring method differs depending on the code Nos. displayed.

1-1. Normal stop

It is displayed in green on the screen. It is not a stop by abnormality of the machine.

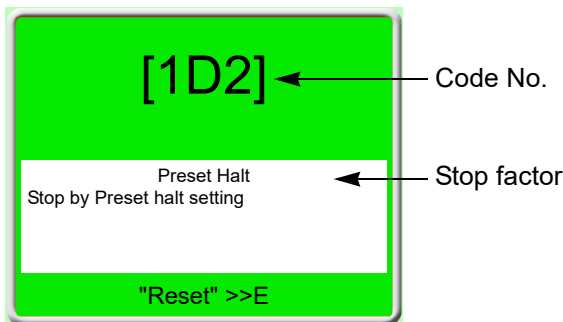

Code Numbers in the chart below are common to models. However, some code No. may not be displayed depending on model.

No.	Stop factor	How to restore
1B1	Stop by frame stepping code	Perform "Start operation" or "Frame back/forward operation", or press any operation key (excluding manual frame travel key) to continue operation of the machine.
1B2	Stop by color change code	
1B3	Stop by end code	
1B4	Stop by thread trimming code	
1B6	Stop by automatic color change (free setting) offset code	
1B8	Stop by temporary stop code	
1C1	Stop by stop switch during frame stepping	Start to the machine.
	Stop by stop switch during trace	To start the operation again, press SET key. To reset the setting, press E key.
	Do not turn OFF the power during display of 1C1. It may not possible to continue embroidery if the power is turned OFF.	
1D1	Stop at all-head sewing start point after frame back	Start the machine and continue embroidery.
1D2	Stop by preset halt (except oil, lochrose)	Press the E key.
1D5	Stop by Preset halt (run out of beads)	
OIL	Preset halt (Oil)	Lubricate to the necessary spots, and press E key.

1-2. Abnormal stop

It is displayed in red on the screen. The trouble will occur when the movement of the machine comes off from normal position etc.

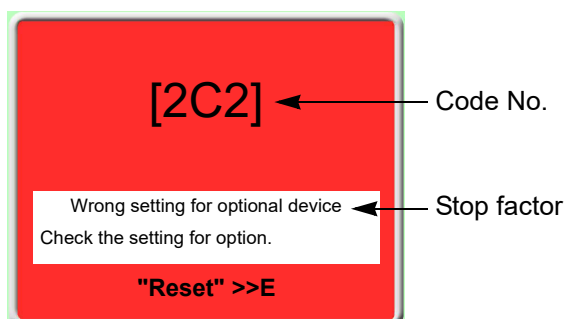

No.	Stop factor	How to restore
211	The main shaft has stopped deviating from the fixed position.	Return the main shaft to the fixed position. Check the main shaft fixed position sensor.
221	The embroidery frame moved to the travel limit position (left) (-X direction).	Move the frame manually so that embroidery can be performed within the set range. *Only the model that has the limit switch at drive system is applicable.
222	The embroidery frame moved to the travel limit position (right) (-X direction).	
223	The embroidery frame moved to the travel limit position (front) (+Y direction).	
224	The embroidery frame moved to the travel limit position (rear) (-Y direction).	
225	The frame move to the limit position during trace.	Press the E key. Check the current frame position.
	The frame moved to the software limit position during trace.	Press the E key. Check setting range of software frame limit.
228	Table up/down operation was performed when the frame was positioned at the front.	Move the frame to the rearmost position.
229	The machine was stopped during Power resume.	Perform Power resume again.
241	M-axis motor is in the state of set free. (TLMX)	Release the state of set free.
251	Oil of lubricating pump is lacking.	Lubricate to the lubrication tank.
255	Operation of Frame Forward or manual frame travel was performed at the other needle height (Z-axis) position than H (Retract Position). (TCMX)	Set needle height to H position.
258	Upper dead point sensor error (ESQ-C)	Check the sensor.
259	Lower dead point sensor error (ESQ-C)	Check the sensor.
25A	Sequin color change sensor error (ESQ-C)	Check the sensor.
271	Nipple motor is in the state of set free. (TLMX)	Release the state of set free.
281	The target needle position is not detected even after 15 seconds from start of color change at FM head.	Return the needle position so that it becomes the correct display. Adjust or replace the potentiometer (needle position sensor).

No.	Stop factor	How to restore
291	Upper thread breakage is detected.	Check thread.
	TC sensor card error	Replace TC sensor card.
293	Under thread breakage is detected.	Check under thread.
294	Absence of sequin material is detected (ESQ-C only).	Check the material.
2B1	Network does not work normally.	Check connecting status of cable, setting status of device such as personal computer.
2B3	Data exists in an end code.	Correct design data.
2B4	Function code error	
2B5	Sequin data error	
2B7	Data set is not completed.	Set data.
2B8	Frame back was performed without data set.	Do not perform frame back.
2BA	Memory capacity exceeded	Delete unnecessary design(s) registered in the memory.
2BB	Available range to perform frame back was exceeded.	Do not perform frame back any more.
	Frame Back operation was attempted without effectiveness of Frame Back function at CM head selection. (TCMX)	Make Frame Back function effective.
2BC	No design is registered in the memory at all.	Register designs in the memory.
	The delete of design in process of embroidery was attempted.	To perform memory delete of design in process of embroidery, perform data input of other data or perform data input of the same design again.
2BE	Start and End codes are not set as a one pair in satin conversion, sequin, boring and low speed code.	Set again so that start and end codes become as a pair.
2C1	Machine was started during setting of data edit or needle bar selection.	Start the machine after ending the setting.
	The machine was started without setting of Automatic Stitch Type Selection. (TCMX)	Perform automatic stitch type selection.
2C2	Setting for option is incorrect.	Set correctly.
2C6	The machine was operated during working of bobbin changer.	Do not operate the machine during working of bobbin changer.
2C7	Wrong password is input.	After pressing E key, input the correct password.
2C8	Sleep mode key was pressed during trace.	Press the E key.
2C9	Time was changed during setting of Password (Time-based Limit).	Press the E key.
2CA	The power is not turned "OFF/ON".	Turn "OFF/ON" the power.
2CE	Stop by safety device	After removing the obstacle, press E key, then press the start switch.

No.	Stop factor	How to restore
2E2	Air pressure of the regulator has become lower than the rated value.	Check the air compressor. Check the origin of air supply.
2E3	Power supply failed during operation.	Perform power resume operation after turning ON the power.
B01	Abnormality occurred in reading/writing.	Copy design to a new USB memory and use it.
B04	USB memory is not inserted.	Insert.
BC1	The design which you try to input is not found in design spooler.	Check the condition of the design spooler.
BC2	The same file name exists in USB memory.	Change the file name.
BC5	Insufficient remaining capacity of USB memory	Replace with a USB memory with enough remaining capacity.
BF1	When Network connection to host personal computer is performed, IP Address could not be obtained from DNS server	Check IP address of DNS server. Correct "IP Setting.ini" file. Check operating condition of DNS server.
BF2	There was some error in the contents of "IP Setting.ini" file for Network setting.	Correct contents of "IP Setting.ini" file.
5B1	It is not possible to input data due to abnormal contents of configuration in TCF design.	Check the design.
5C1	Data set was performed without frame origin memory after installation of software. The machine was stopped during operation of frame origin memory.	Perform frame origin memory.
5C2	Machine was started during moving up/down of Sequin device.	Start the device after completion of up/down.
5C3	Setting error of ESQ-C	Check the setting of panel.
5C6	General external device is operating.	Operate the machine after general external device is stopped.

1-3. Stop due to malfunction

It is displayed in red on the screen. It is caused by card, harnesses or communication error. If the below code numbers are displayed, consult the distributor.

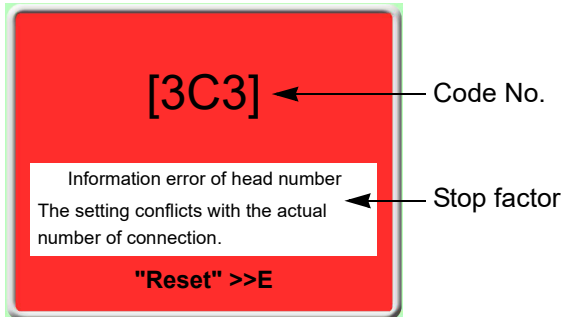

No.	Stop factor	How to restore
311	Encoder A signal status does not change for 5 seconds. Motor or motor belt failure. (It is not displayed in single head machine.)	Check the connection of encoder signal wire. Check the excitation of the main shaft driver. Check the motor or the motor belt.
312	Fixed position signal (1-rotation signal) does not change during operation.	Press the E key. Check the connection of the main shaft motor or the photo-interrupter card. If it is not possible to recover from the trouble, replace the main shaft motor or the photo-interrupter card.
316	Main shaft motor error or main shaft driver error	316, 322-*, 323-*
317	Take-up lever clutch error (TLMX)	
322-*	Abnormality of X-axis driver *Description of mark differs depending on factor. The same is applied to No.323.	
323-*	Abnormality of Y-axis driver	
32A	The machine cannot memorize excitation of X-axis driver.	Turn "OFF/ON" the power. Check connection of each frame driver motor and/or sensor wire.
32B	The machine cannot memorize excitation of Y-axis driver.	
32C	Incompletion of X-axis frame travel	Replace the corresponding frame driver or frame motor.
32D	Incompletion of Y-axis frame travel	
32E	The machine cannot complete X-axis origin search within the time.	Turn "OFF/ON" the power. Or switch from sleep mode to normal mode. (Each driver setting will be reset.) When it is not possible to recover from the trouble, replace the card.
32F	The machine cannot complete Y-axis origin search within the time.	
		Check setting for embroidery space at software installation. Check the sensor card.

No.	Stop factor	How to restore
331	Abnormal signal of bobbin changer has been detected.	Operate the bobbin changer manually after resetting the error, and check/adjust the place where motion error occurred.
347	Control error of M-axis drive motor (TLMX, TCMX)	Turn "OFF/ON" the power. Replace motor, mechanical parts, or head card of the corresponding head.
353	Abnormality occurred in up/down color change driver (ESQ-C only).	Check the card.
354	Sequin motor overcurrent Overcurrent of color change motor and ATH motor (Only single head machine excluding TCMX-601 is applicable.)	Turn OFF/ON the power. Check and/or replace the head card. Decrease R.P.M.
362	Jump motor overcurrent	
371	Control error of nipple drive motor (TLMX)	Turn "OFF/ON" the power. Replace motor, mechanical parts, or head card of the corresponding head.
382	The needle position signal status during color change does not change for 1 second and more.	Check the color change motor and power supply circuit. Check the potentiometer (needle position sensor).
383	Needle position was abnormal.	Check setting for the number of needles at installation of software.
	There was no needle position signal during rotation of the main shaft.	Check the potentiometer (needle position sensor).
384	Control error of D-axis drive motor (TCMX)	Turn "OFF/ON" the power. When the machine is not restored even after that, replace the head card of the corresponding CM head.
385	Malfunction of Z-axis (TCMX)	
387	Color change motor sensor error	Check encoder signal wire of color change motor.
3A6	ATH movable knife retractable position has become nonuniform.	Check the position of ATH movable knife.
3A9	Upper thread holding motor overcurrent	Turn OFF/ON the power. Check and/or replace head card.
3B5	Communication error (between CPU card USB hub), power supply system error of 280 V or 24 V, abnormality of power supply card	Check harness connection between CPU card and USB hub. Check and/or replace power supply card. Check and/or replace DC power supply.
	Wrong selection of model at installation of software	Install the software again.
3B5 MC	Communication error (among CPU card, USB hub and machine card), USB communication error due to color change position, 24 V power supply system error, power supply card error	Check harness connection among CPU card, USB hub and machine card. Check and/or replace power supply card. Check and/or replace 24 V power supply.

No.	Stop factor	How to restore
3B5 S	Communication error (among CPU card, USB hub and main shaft driver), USB communication error due to color change position, 280 V power supply system error, power supply card error	Check harness connection among CPU card, USB hub and main shaft driver. Check and/or replace power supply card.
3B5 X	Communication error (among CPU card, USB hub and X-axis driver), USB communication error due to color change position, 280 V power supply system error, power supply card error	Check harness connection among CPU card, USB hub and X-axis driver. Check and/or replace power supply card.
3B5 Y	Communication error (among CPU card, USB hub and Y-axis driver), USB communication error due to color change position, 280 V power supply system error, power supply card error	Check harness connection among CPU card, USB hub and Y-axis driver. Check and/or replace power supply card.
3B7	Communication error inside the controller, bad communication (between CPU card and switch card)	Turn "OFF/ON" the power. Check harness connection between CPU card and switch card. Replace CPU card or switch card.
3B8	Impossible communication with ESQ-C	Check the sequin controller card or connection.
3B9	Communication error of up/down color change driver (ESQ-C only).	Check the sequin driver card (Occurred only when power is turned ON).
3BA	Communication error with ESQ-C	Check the sequin controller card or connection (Occurred only when power is turned ON).
3BC MC	Communication speed error (machine card)	Check/replace machine card.
3BC S	Communication speed error (main shaft driver)	Check and/or replace the main shaft driver.
3BC X	Communication speed error (X-axis driver)	Check/replace the X-axis driver.
3BC Y	Communication speed error (Y-axis driver)	Check/replace the Y-axis driver.
3BD MC	Error of ID written to the card. Driver not for machine card is connected.	Check/replace machine card.
3BD S	Refer to 3BD (MC) described above. Driver not for the main shaft is connected.	Check and/or replace the main shaft driver.
3BD X	Refer to 3BD (MC) described above. Driver not for X-axis is connected.	Check/replace the X-axis driver.
3BD Y	Refer to 3BD (MC) described above. Driver not for Y-axis is connected.	Check/replace the Y-axis driver.
3BF	Remaining number of beads cannot be grasped.	Check and/or replace the head card.
3C1	Contact error of the bar switch or start/stop switch, breakage of the switch harness, or bad connection of the connector	Check the connector and the connecting terminal. Replace the limit switch/switch assembly.

No.	Stop factor	How to restore
3C2	Table offset switch is in the state of pressed (Only when turning ON the power, canceling sleep mode).	Check the signal wire of table offset switch.
3C3	Mis-setting of the number of heads in "Machine Type"	Check the contents of setting.
3D6	There is abnormality in the program or in the CPU card.	Check the CPU card.
	The software is not installed normally.	Install the software.
3DB	System RAM insufficient capacity	Turn "OFF/ON" the power. Replace CPU card.
3DC	Memory device error	Turn "OFF/ON" the power. Install the software. Replace the DOM or CPU card.
3DD	System installation error	Install the software. Replace DOM or CPU card.
3DE	External memory device error	Turn "OFF/ON" the power. Check/replace the USB memory, or replace the CPU card.
3F1	Tension release error (thread tension control error) (TCMX)	Turn "OFF/ON" the power. When the machine is not restored even after that, adjust/replace the tension release potentiometer.
6D1	File error of frame drive parameter	Install the software.
6D2	Disconnection of communication line	Turn "OFF/ON" the power. Check harness connection between CPU card and USB hub. Check and/or replace power supply card. Check and/or replace DC power supply. Install the software again.
6D3	Disconnection of USB communication line in I/O card, communication error	Turn "OFF/ON" the power. Check connection of USB cable Check and/or replace power supply card. Check and/or replace DC power supply. Install the software again.

2. Trouble examples and Corrective actions (CM head)

2-1. The machine does not sew well

The following causes could make uneven loop height, bad tightening of chain stitch, shaggy, mis-stitch, or thread breakage etc.

Cause	Corrective Action
Bad thread tension	Adjust the thread tension.
Thread quality is bad.	Use good quality thread.
Unwoven cloth is weak.	Use durable unwoven cloth or interlining cloth.
Needle quality is bad. It is bent.	Replace the needle or needle bar.
Needle bar is bent.	
Inside of nipple is clogged with dust.	Clean.
Attaching angle of needle (needle bar) is bad.	Perform "D-axis Origin Return" to check if the hook part of needle faces to the front.(→p.85)
Setting for needle height does not fit to stitch length of design.	Change the needle height.
Stitch length of design is not stable.	Make stitch length the same in the same step (Recommended value is 5 mm or less).
Bad combination of thread, needle and nipple	Change the combination.(→p.24)
Nipple height is bad.	Perform adjustment so that the nipple touches the needle plate lightly at the lower dead point of the nipple.
Run-out of oil of needle bar	Grease.
Scratches on thread course of looper and/or needle plate	Grind the scratch. Replace the part.
Position of looper is mis-aligned.	Perform "D-axis Origin Return" to return the looper shaft to the origin. (→p.85)

2-2. Needle breaks

Cause	Corrective Action
Thread tension is too strong.	Adjust the thread tension.
The fabric is hard or too thick.	Change the fabric. Use needle of higher count number.
Density of design data is too high.	Correct design data. Use needle of higher count number.
Stitch length is too long.	Correct design data (Recommended value is 5 mm or less).

2-3. Needle hooking on the fabric

Cause	Corrective Action
Needle is too thick against the fabric/thread.	Change needle count number. Use PH-C120 type needle.
Stretching of the fabric or interlining cloth is weak.	Stretch the fabric strongly.
Bad combination of thread, needle and nipple	Change the combination. (→p.24)
Nipple height is bad.	Change the height.

2-4. Thread cast-off, mis-stitching

Cause	Corrective Action
Thread tension is too strong.	Adjust the thread tension.
Dust piles up around the looper.	Clean.
Wrong setting of "Tie stitches"	Change the value. (→p.89)
Tension of thread take-up lever is strong. Stroke is large.	Adjust.

2-5. To suspend the head with occurrence of error

When it becomes impossible to perform embroidering by all heads due to malfunctioning of tension base card, this working makes the remaining heads perform embroidering by making the head with occurrence of trouble become suspended head.

[Operation procedure]

- (1) Press F5 key within ten seconds after turning ON the power and keep on pressing it. If the software version appears, release it. The below screen will appear.

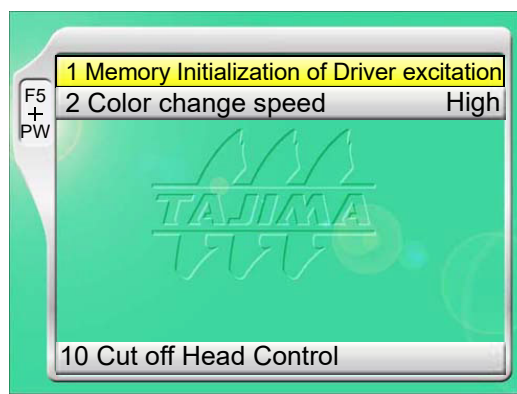

(2) Select "10 Cut off Head Control" and press SET key.

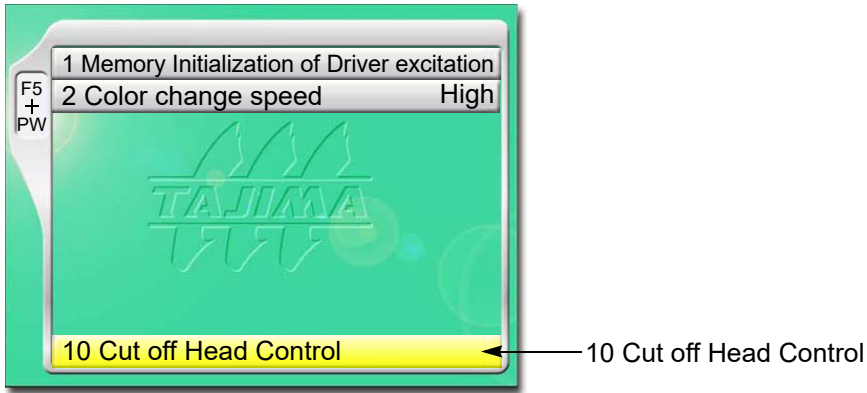

(3) Select the head which you want to cut off control. (Example: 4th head)

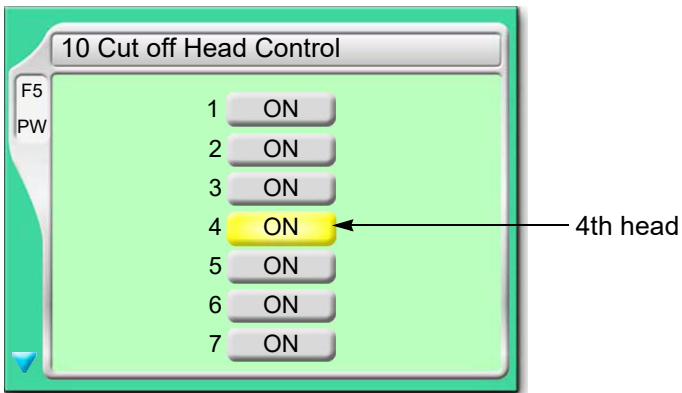

(4) Select "OFF" and press SET key.

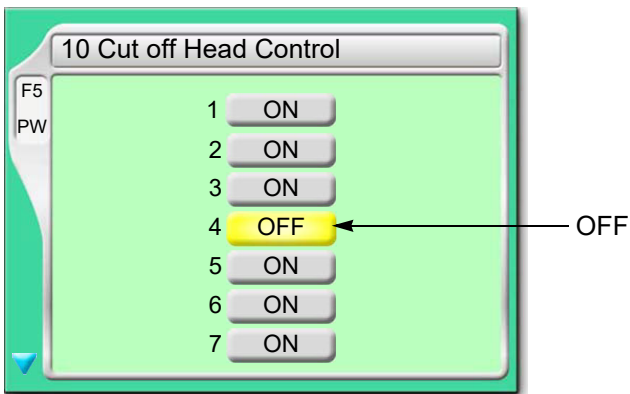

(5) Turn OFF/ON the power.

2-6. To excite the motor

This function makes the following Motor Excitation to turn ON/OFF temporarily. Use this function mainly for machine adjustment and maintenance.

(a) X-axis or Y-axis motor

When starting the machine with the excitation turned OFF, error will occur. To restore the machine, turn OFF and ON the power.

(b) Jump motor, ATH motor and sequin motor

[Operation procedure]

- (1)** Set to the main screen.
- (2)** Press F3 key while pressing SET key.
- (3)** Select "4 Motor Excitation".

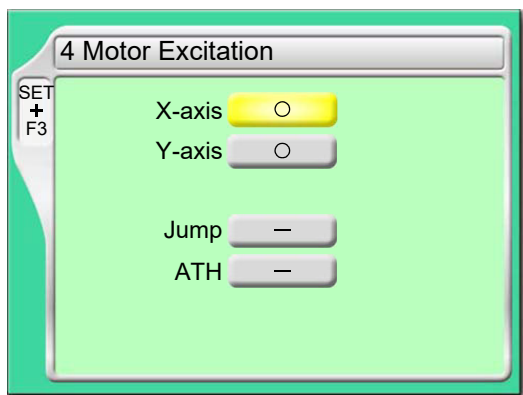

In the state of each motor excitation

- : Excitation ON
- : Excitation OFF

- (4)** Select the excitation (ON or OFF) of the motor you want, then press SET key.

3. Trouble examples and Corrective actions (FM head)

3-1. Thread breakage is highly visible.

Cause	Troubleshooting
Bad thread tension	Adjust tension. The values described below are rough standards. Adjust according to the condition. Upper thread: 120 to 140g, under thread: 20 to 30g
Quality of thread is bad. Poor thread flow	Use good quality thread. Spray silicone.
Direction of needle is bad or needle bents.	Adjust to face to the front or to the right a bit. Replace.
Applique glue is stuck on needle.	Remove adhered glue.
Contamination, run-out of oil of rotary hook	Clean and lubricate the machine.
There are many fine stitches of 0.5 mm or less in design data.	Remove fine stitch(es).
The fabric is lifted too much against the needle plate. The fabric touches the needle plate too much.	Stretch the fabric again so that it touches needle plate lightly.
Run-out of oil of needle bar	Lubricate.
There is a scratch on the thread course.	Grind a scratch with sandpaper etc. Replace.
Bad height of the presser foot	Perform adjustment so that height fits to fabric/material.

If the followings seem to cause the trouble, please ask the distributor for information.

- (a) The gap between rotary hook and rotary hook support is narrow. Timing between needle and rotary hook is too early or too late. Scratch, abrasion of rotary hook.
- (b) A clearance between needle and hook point is not suitable. Bad adjustment of lower dead point and/or upper dead point of needle bar.
- (c) The play of rotary hook shaft is big in back and forth direction. There is a play on the fringe of the frame.
- (d) Rotation of the main shaft is not smooth. Abrasion/breakage of neighboring parts of take-up lever drive and/or needle bar drive section.
- (e) Play of needle bar case (in right and left direction) is big.

3-2. Needle breaks

Cause	Troubleshooting
Bad thread tension	Adjust tension.
Density of design data is very high.	Correct data. Delete unnecessary underlay stitching.
The material is too thick or hard.	Use material suitable for embroidery.
Bobbin is deformed and it touches the needle.	Replace the bobbin.
Bad quality of needle, mis-matching to embroidery condition	Use good quality needle. Use needle that fits to embroidery condition.
Vibration of the machine is big.	Adjust leveling.

If the followings seem to cause the trouble, please ask the distributor for information.

- (a) Abrasion of needle catcher of rotary hook. A clearance between needle and hook point is not suitable.
- (b) Bad needle location. Play of needle bar case (in right and left direction) is big.
- (c) The floor vibrates. There is a play on the fringe of the frame.

3-3. Bad finishing of embroidering

Cause	Troubleshooting
Bad thread tension	Adjust tension.
Quality of thread is bad. Poor thread flow	Use good quality thread. Spray silicone.
Density of design data does not match with material and/or thread.	Correct data.
Bad frame attaching and fixing of the fabric	Attach the frame correctly. Fix the fabric firmly.
Thread, needle and/or size of needle plate do not match with embroidery.	Make combination that fits to design data/material.
R.P.M. is too high.	Decrease R.P.M.

If the followings seem to cause the trouble, please ask the distributor for information.

- (a) There is a play on the fringe of frame.
- (b) Abrasion and breakage of neighboring parts of take-up lever drive and needle bar drive.
- (c) Bad take-up lever timing.
- (d) Belt tension of drive system is too strong or too weak.
- (e) Setting for the machine does not match embroidery condition.

3-4. To suspend the head with occurrence of error

When it becomes impossible to perform embroidering by all heads due to malfunctioning of tension base card, this working makes the remaining heads perform embroidering by making the head with occurrence of trouble become suspended head.



DANGER



To detach the wiring cover, be sure to turn OFF the power. Card that generates high voltage is attached to the back face of the square pipe. There could be danger of electric shock.

[Working procedure]

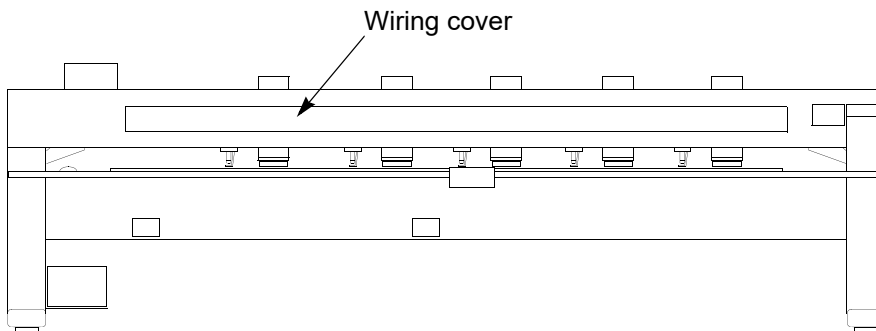
(1) Detach the wiring cover.



(2) Connect the jumper connector (accessory) to the head card.

Example:

To suspend the 3rd head (odd-numbered head), connect the jumper connector to the connector CN9.

 One piece of the head card is used for two heads.

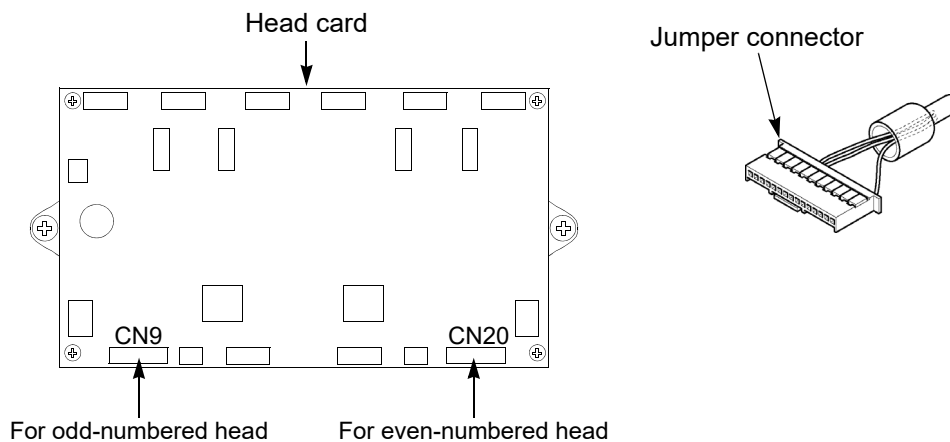

Chapter 11

Maintenance and Inspection

1. Items that must be followed carefully.....	244
2. Cleaning.....	246
3. Lubrication	249
4. Greasing	253
5. Inspection, Repair.....	257
6. Adjustment of the middle thread guide	258

1

2

3

4

5

6

7

8

9

10

11

12

1. Items that must be followed carefully

! DANGER

! The spots as shown below are attached with cards that generate high voltage. Other personnel than the service man approved by TAJIMA should not open the covers. You could get an electric shock of high voltage.

The figure shows TCMX-mixed type series. TCMX-600 series is also the same in positions.

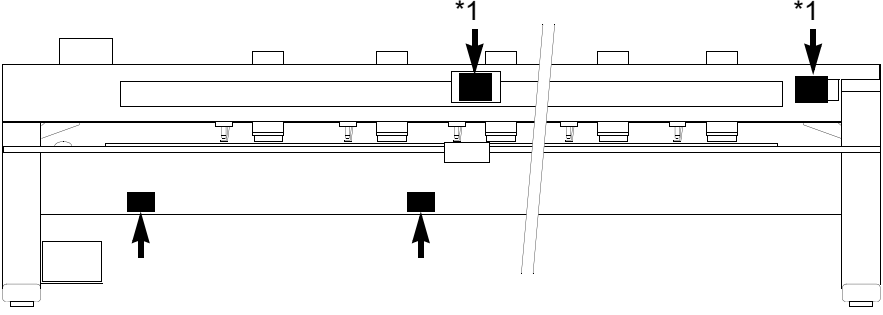

*1
Either one card is equipped. (It differs depending on model.)

! WARNING

- !** Daily maintenance (cleaning, lubrication, greasing, inspection) should be performed by personnel who has been trained properly.
- !** "Repair" and "Replacement of electrical component" must be done only by the service personnel assigned and trained by Tajima or qualified technician. (Consult your distributor.)
- !** When starting operation again, attach all the detached covers as they originally were.

CAUTION

- ❗ Perform daily maintenance (cleaning, lubrication, greasing, inspection). Neglect of daily maintenance could cause troubles. Damage due to neglect of daily maintenance may be judged as "Outside the scope of warranty".
- ❗ If the machine is not used for a long period, turn the power switch ON in regular intervals. Although each card of the machine has a backup battery, data may be lost for about one month because voltage of the battery will come down gradually due to discharge when power switch is turned off.
- ❗ Assure enough illumination. Assure 300 lux or more for working areas including underneath part of the machine table when changing under threads or performing daily maintenance.
- ⊘ Do not turn ON the power with the main shaft fixed. The machine could be broken.
- ⊘ Do not start the machine with the needle bar (Figure A) detached. Starting the machine with the needle bar detached will cause the parts in the arm to be broken.
- ⊘ Do not tighten screws (Figure B). Over-tightening screws will cause the needle bar not to reciprocate u/down smoothly.
- ❗ After tightening screws, check if the needle bar reciprocates up/down smoothly. (Figure C)

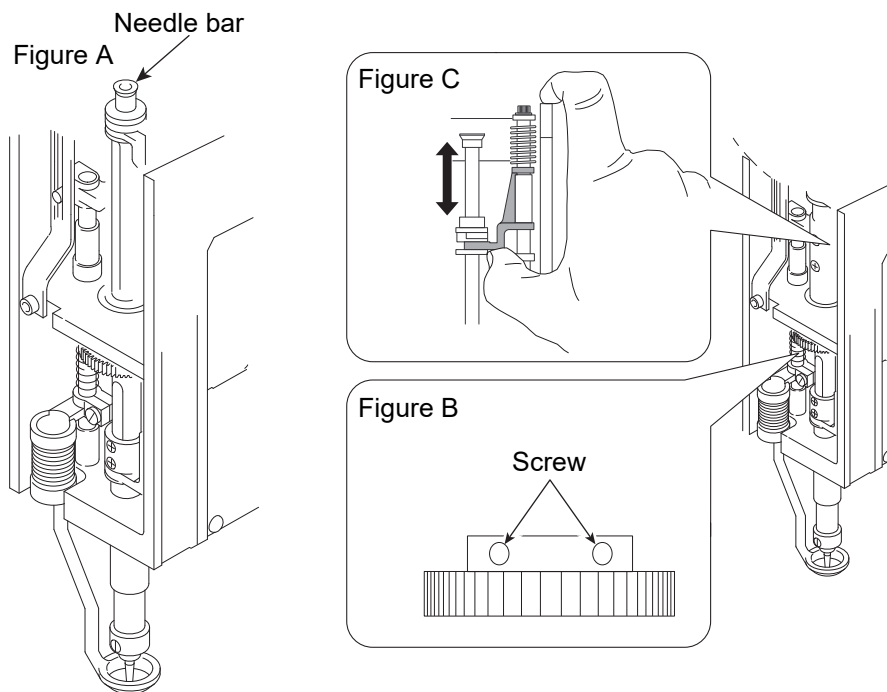

2. Cleaning

WARNING

 When performing cleaning, be sure to turn off the power switch. You could be injured seriously by being entangled in the machine.

Clean each section by using a commercially available cleaning tool or brush (accessory). Using of an Vacuum Cleaner or an Air Compressor will facilitate working.

Main cleaning spots are indicated by an arrow in the figure below. If dirt is highly visible at other spots besides these spots, clean up there accordingly.

(1) CM head

Cleaning area	Cycle
1. Nipple connecting stud, 2. Nipple, 3. Needle plate, 4. Tension base	Once/week
5. ATH, 6. Spur gear, 7. Looper, 8. Looper sleeve	Once/3 months

After cleaning the looper case, grease each section.

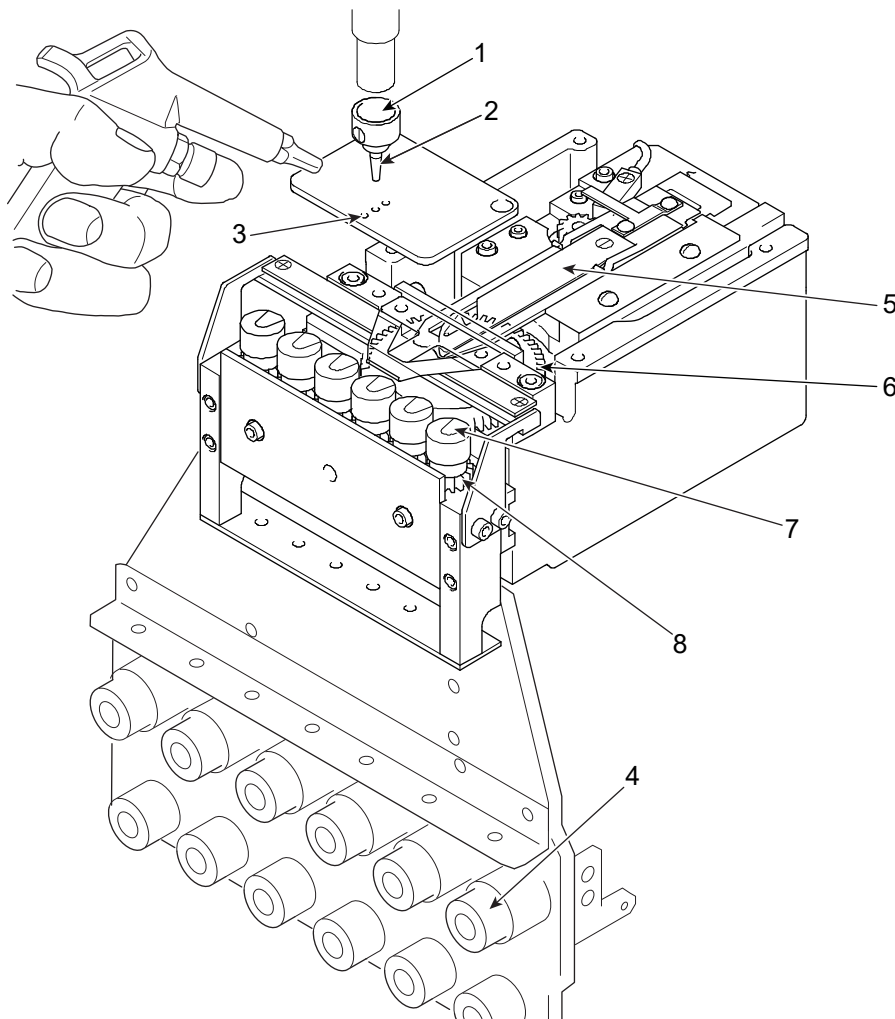

(2) FM head

Cleaning area	Cycle
1. Tension disk, 2. Thread presser, 3. Linear way, 4. Clutch lever, 5. Drive lever	Once/week
6. ATH, 78. Rotary hook	Every day

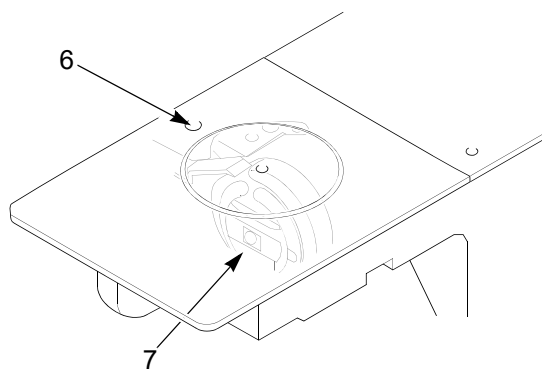
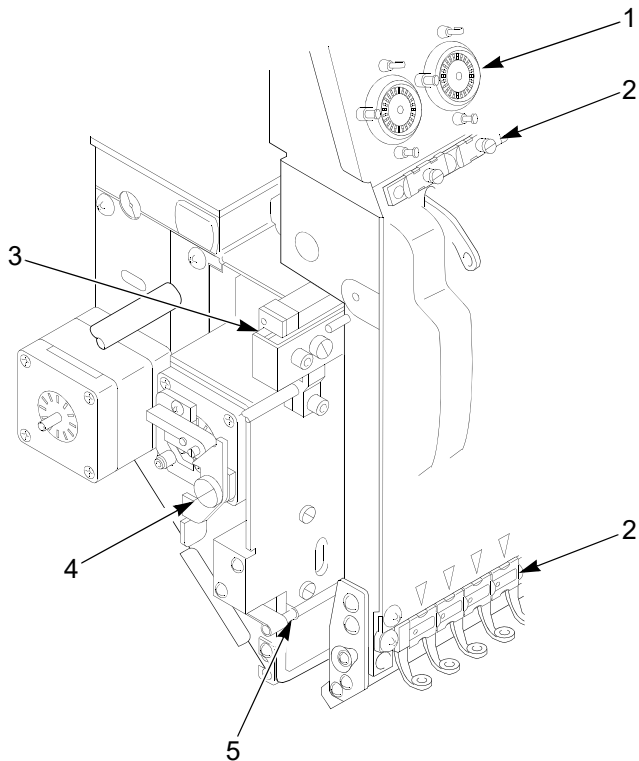

An example when using a cleaner
Brush

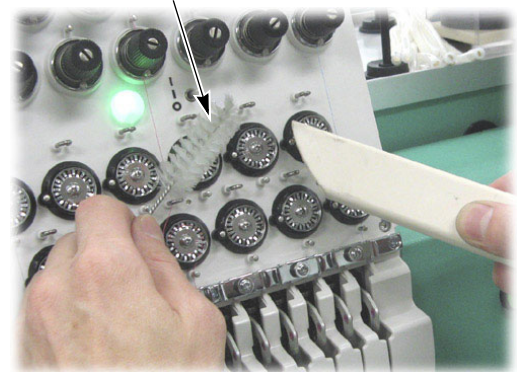

(3) Drive system

Cleaning area	Cycle
1. X-axis drive system, 2. Y-axis drive system	Once/week

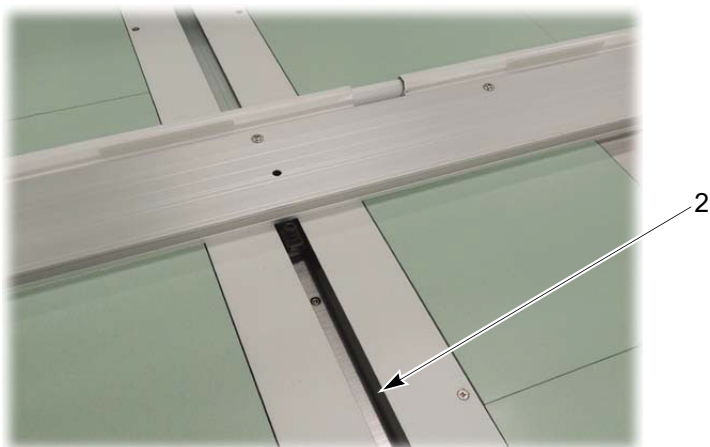
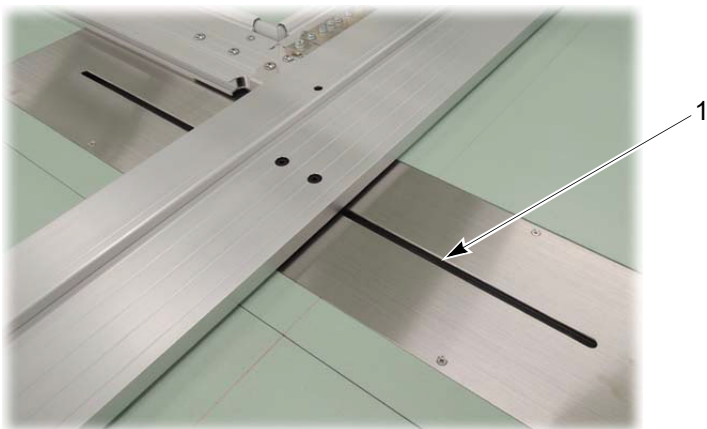

3. Lubrication

WARNING

 To perform lubrication of the machine, turn off the power switch. You may sustain severe injuries due to being entangled by moving machine units.

Select TF oil (packed with the machine), or the equivalent (viscosity grade = equivalent to VG20) to this one for use.

To perform lubrication, use the oiler (accessory) and its nozzle (accessory).

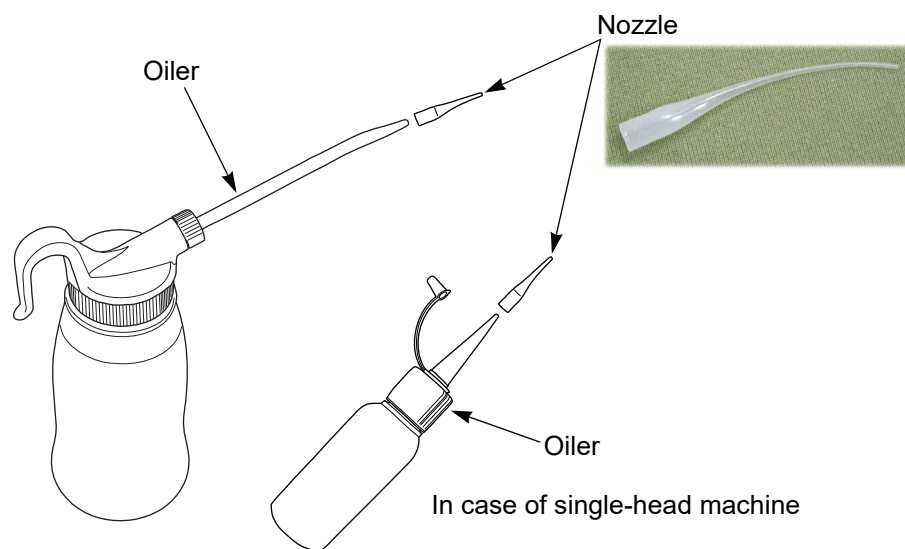

(1) CMHead

Lubricating spot	Cycle
1. Drive lever, 2. Sleeve, 3. Connecting rod, 4. Slide block, 5. Connecting block 6. Needle bar	Once/week

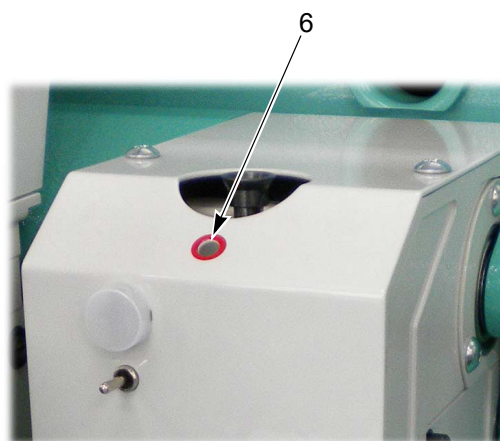
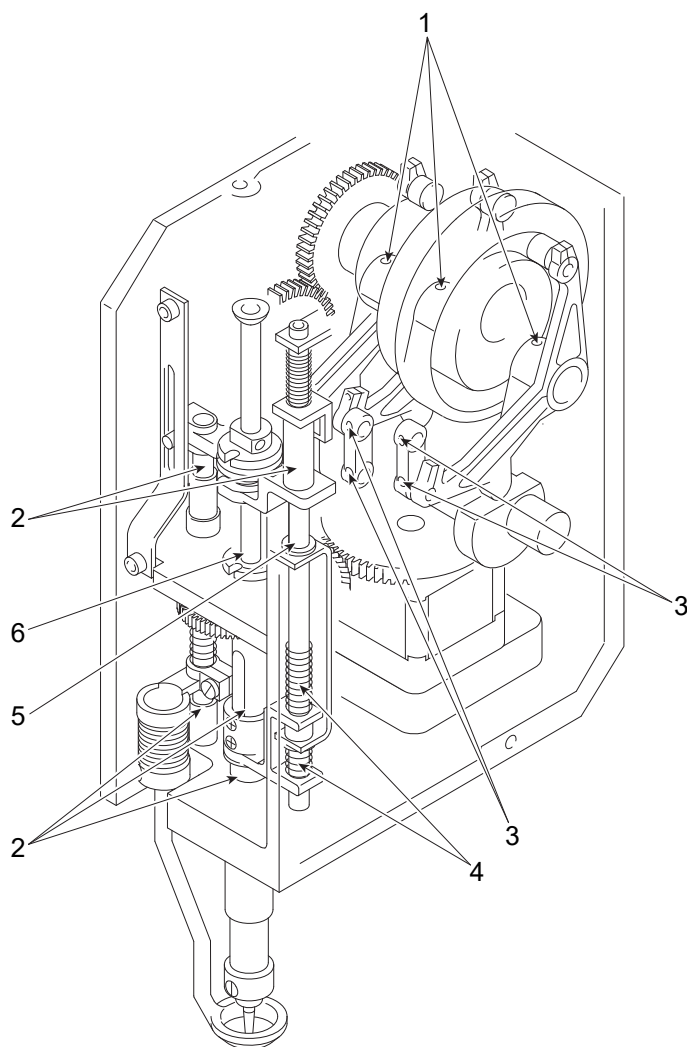

(2) FM head

Lubricating spot	Cycle
1. Needle bar, 2. Needle bar drive shaft, 3. Wick 4. Connecting rod, Lever, 5. Lever, 6. Connecting rod	Once/week

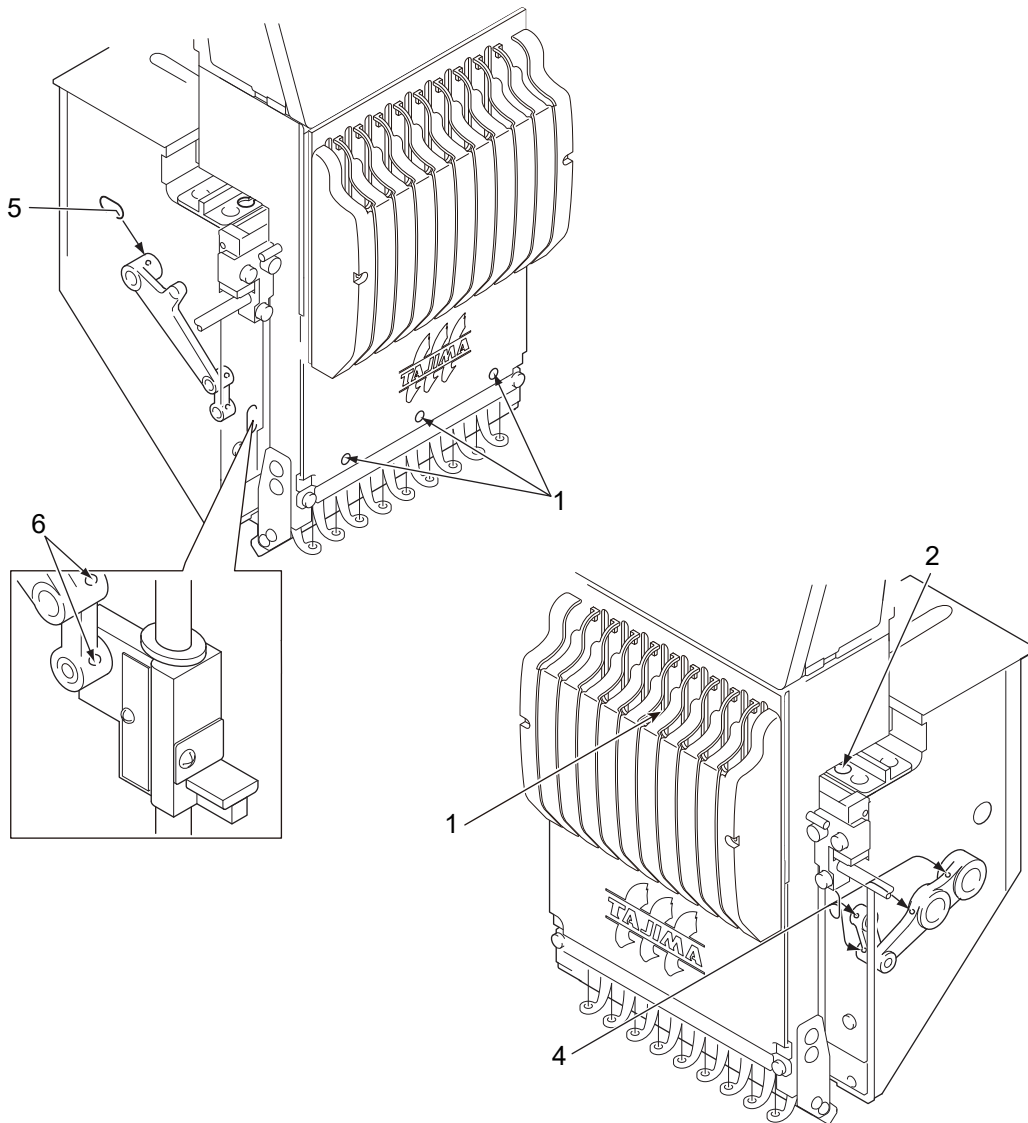

1
2
3
4
5
6
7
8
9
10
11
12

Lubricating spot	Cycle
7. Lubrication hole of rotary hook, 8. Raceway	Once/5 to 6 hours

There are two lubricating spots (the lubrication hole and the raceway). When lubricating to the lubrication hole, attach the nozzle (accessory) to the tip of the oiler.

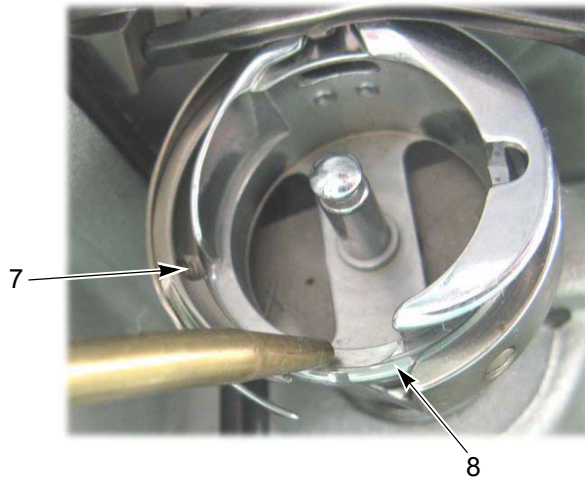



4. Greasing

Before greasing, consult the distributor.

WARNING

 During machine greasing, turn off the power switch. You may sustain severe injuries due to being entangled by moving machine units.

CAUTION

 Use a grease specified(described below) by TAJIMA or equivalent to keep the lubricity inside of the head normally. Use of the grease except these could cause trouble due to deterioration of the lubricity. Regarding how to obtain it, consult the distributor.

[Items specified by TAJIMA]

Item name	Item No.	Base oil	Thickener
GREASE :KING STAR EP NO.2 :400G	750103004000	Refined mineral oil (about 75%)	Lithium soap (about 15%)
SPRAY GREASE :NIG LUBE PG :300ML	750104001000	Olefinic synthetic oil	Lithium soap

Grease manufacturer: NIPPON GREASE Co.,Ltd.

URL: <http://www.nippon-grease.co.jp/>

(1) CMHead

Greasing spot	Greasing cycle	Grease to use
1. Cam, 2. Spur gear 3. ATH section	Once/3 months	SPRAY GREASE :NIG LUBE PG : 300ML

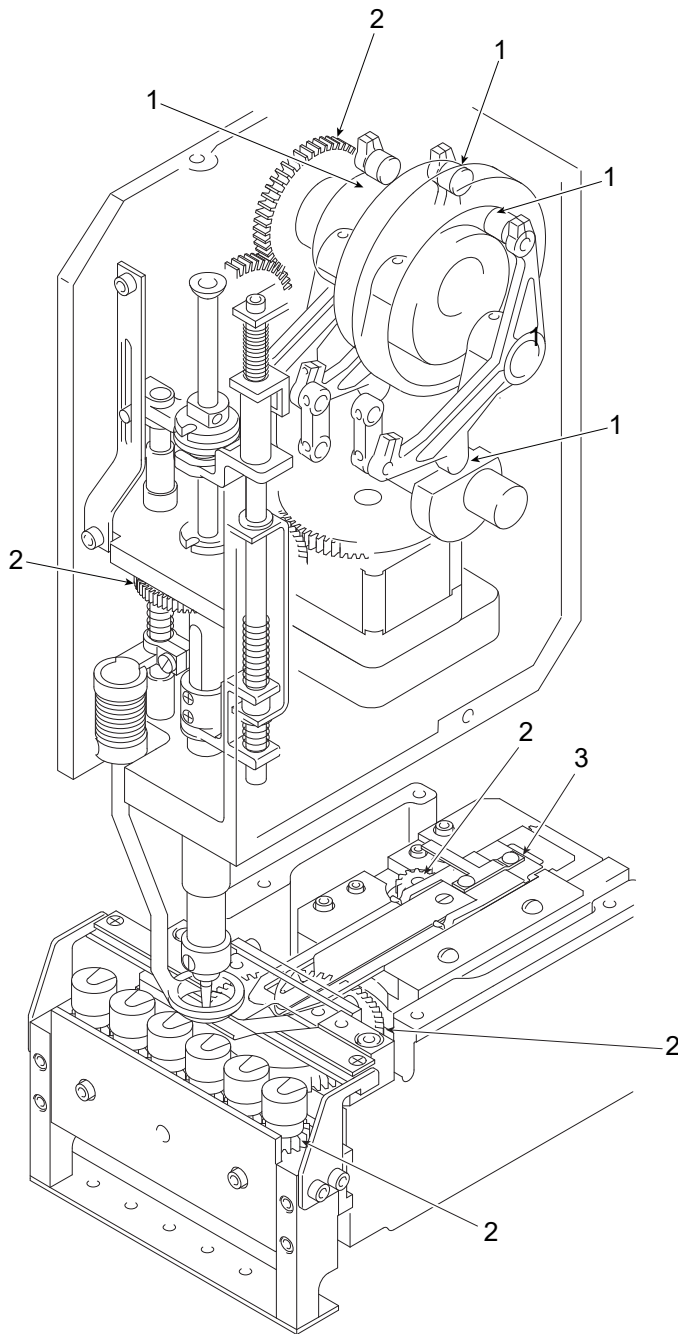

(2) FM head

Greasing spot	Greasing cycle	Grease to use
1. Bearing case ^[*1] 2. Roller 3. Cam	Once/3 months	SPRAY GREASE :NIG LUBE PG :300ML

*1: Inject grease from the hole of the bearing case lid by using the syringe.

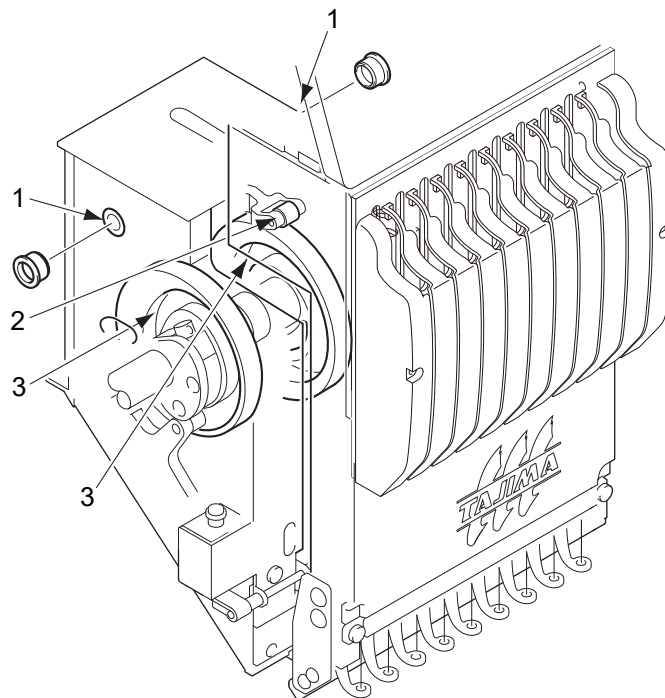
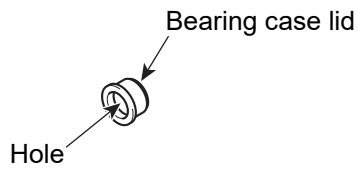

Greasing spot	Greasing cycle	Grease to use
4. Rotary hook base gear	Once/3 months	GREASE :KING STAR EP NO.2 :400G

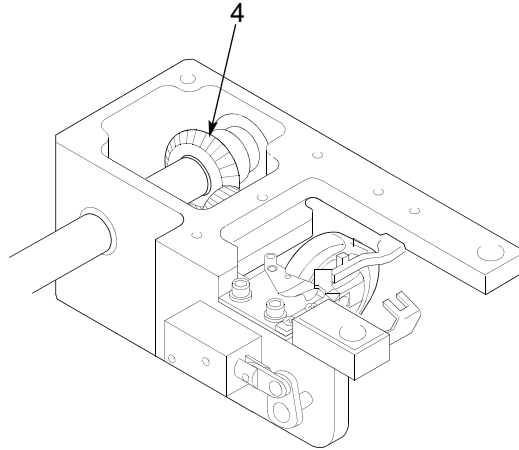

Greasing spot	Greasing cycle	Grease to use
5. ATH cam,	Once/6 months	GREASE :KING STAR EP No.2 :400G

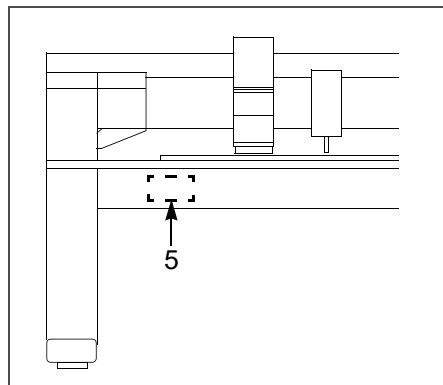
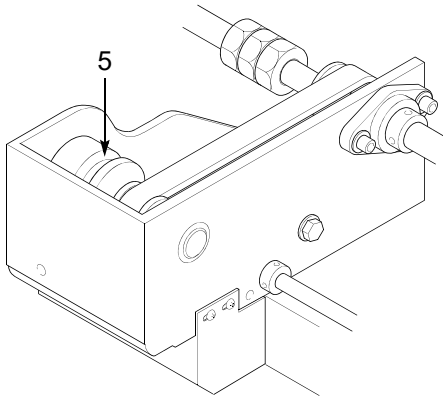



5. Inspection, Repair

 WARNING

 Before inspection, be sure to turn off the original power supply. Some circuits are still applied voltage eve if the original power supply was turned off. Wait until these circuits are completely out of voltage (4 minutes) and then start working.

Inspection point	Action	Inspection cycle
Attaching of each type of cover	Attach all the covers.	At start of working
Setting condition of embroidery thread	Set it correctly.	
Check breakage and/or bent of needle.	Replace the needle.	
Lubricating condition of each section	Lubricate.	
Automatic Lubrication System	Refill oil.	
Belt tension (main shaft, X/Y drive system)	Consult the distributor.	Once/3 months

 WARNING

 Before repairing the machine, be sure to turn off the original power supply. Some circuits are still applied voltage eve if the original power supply was turned off. Wait until these circuits are completely out of voltage (4 minutes) and then start working.

 If the machine needs the repair, the repair must be done only by the service personnel assigned and trained by Tajima or qualified technician. (Consult your distributor.) Do not change the specification nor modify the parts of the machine without due consultation with Tajima. Such modification may have the risk against the operational safety.

 When restarting the machine after repairs, attach all removed covers etc. as they were.

 CAUTION

 For the repair, use Tajima genuine parts for replacement.

6. Adjustment of the middle thread guide

6-1. Snap-fit middle thread guide (for regular rotary hook machine)

To adjust the stroke amount of the thread take-up spring inside the snap-fit middle thread guide, follow the procedure below.

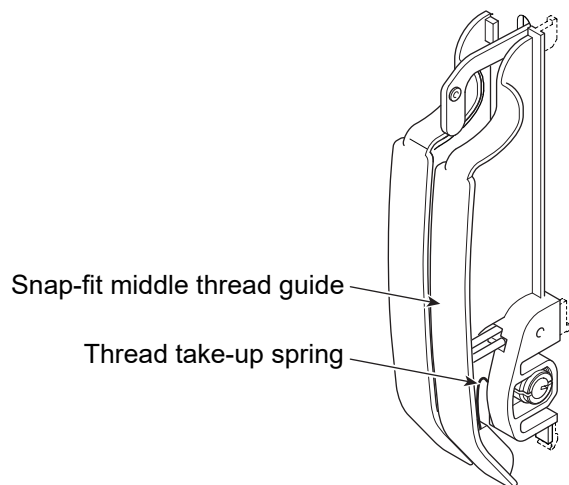

[How to adjust]

- (1) Push the pawl with some thin-tipped stick (Fig. A), and release the pawl from the top cover and pull it to the front (Fig. B).

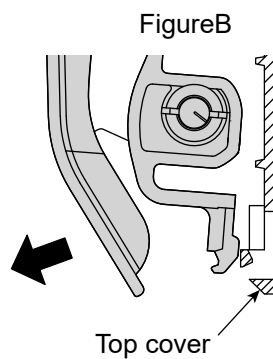
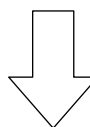
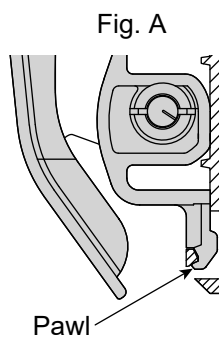
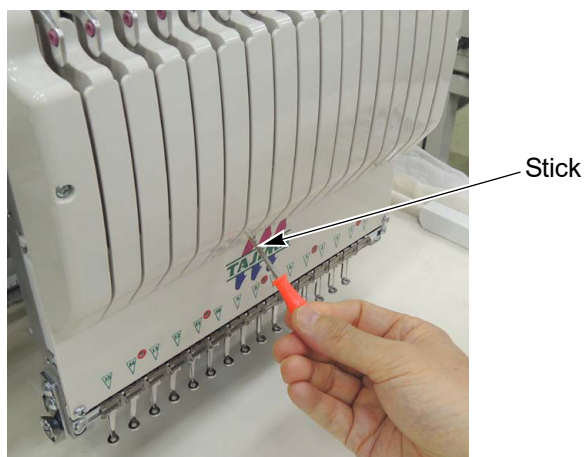

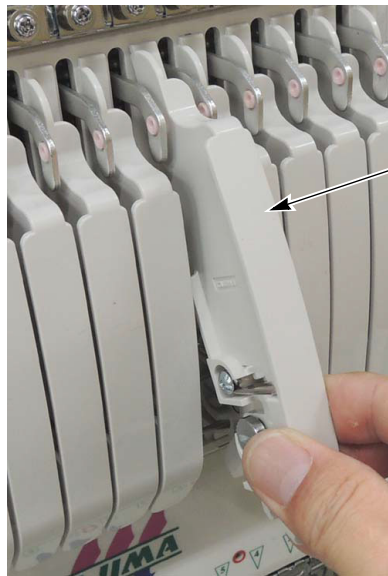

(2) Detach the snap-fit middle thread guide.

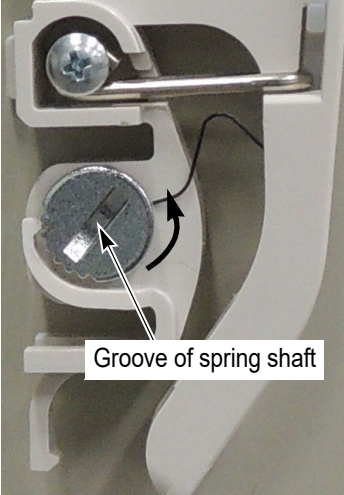

Snap-fit middle thread guide

(3) To adjust stroke of the thread take-up spring, put some coin, etc. in the groove of the spring shaft and turn the spring shaft.

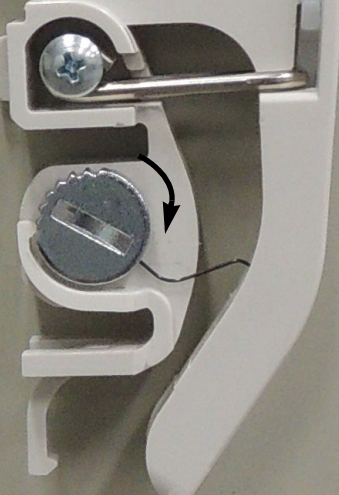
Minimum stroke	Standard stroke	Maximum stroke
Click three times in the counterclockwise direction	Position at shipment from the factory	Click once in the clockwise direction
 <p data-bbox="389 1559 619 1592">Groove of spring shaft</p>		

- (4) Put the pawl in the slit (Photo A), push up the locking pawl with your thumb and put it in the hole (Photo B).

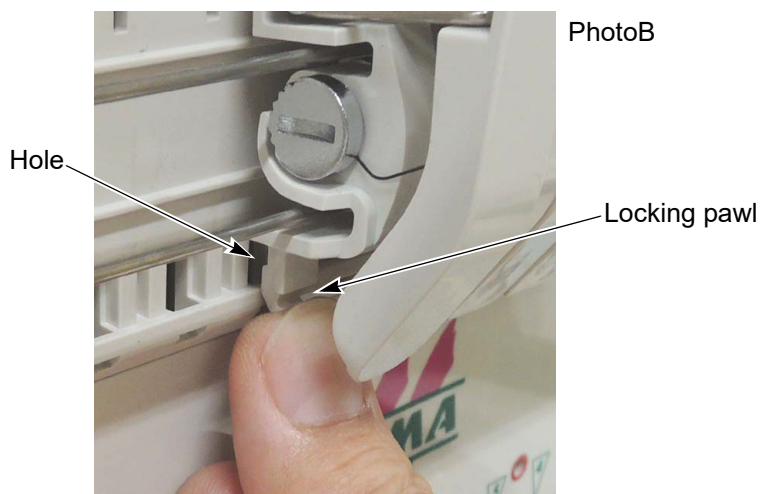
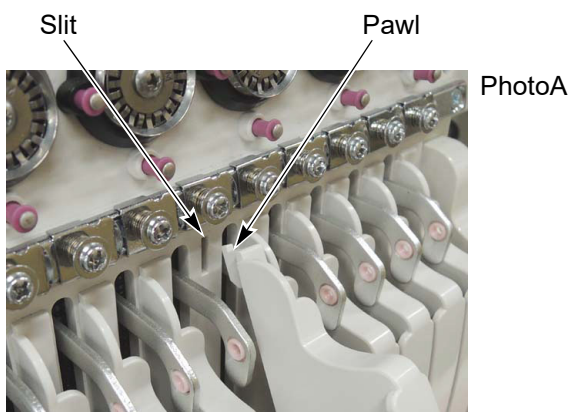

- (5) Push the snap-fit middle thread guide securely to fit until it clicks into place.

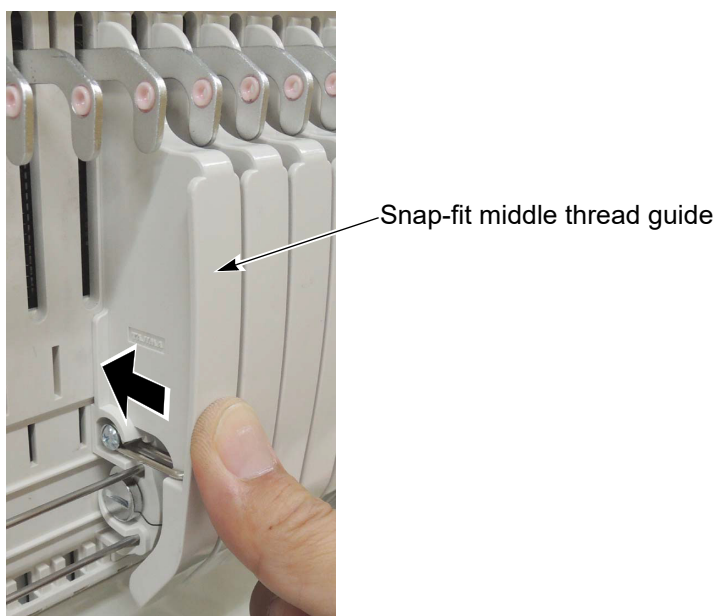

6-2. One-touch middle thread guide (for jumbo rotary hook machine)

To adjust the stroke amount of the thread take-up spring inside the one-touch middle thread guide, follow the procedure below.

[How to adjust]

The following is the example of adjusting the stroke amount of the thread take-up spring at the third needle.

(1) Remove the screw 1, and detach the front face cover.



(2) Insert hexagon wrenches (1.5 mm) into the groove and the screw hole.

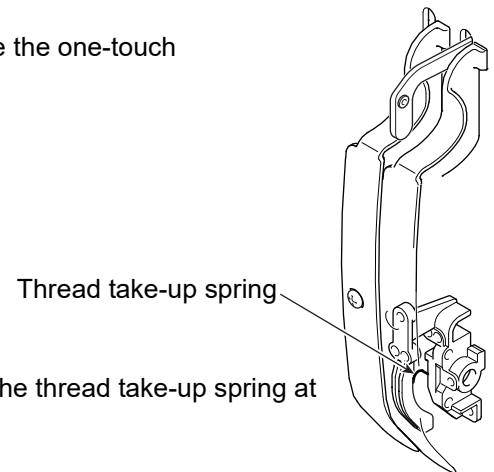
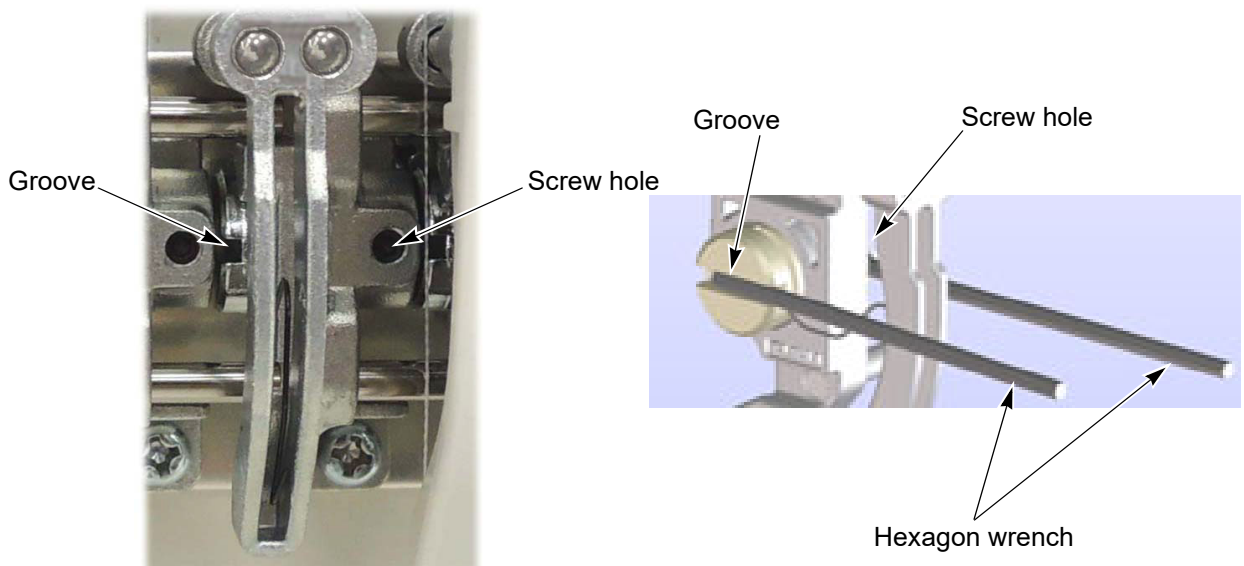

1

2

3

4

5

6

7

8

9

10

11

12

(3) When you want to loosen the thread tension, loosen the screw 2, and turn the spring shaft up.

Tighten the screw 2 while pushing the spring shaft to the right direction (the direction of black arrow in the figure below).

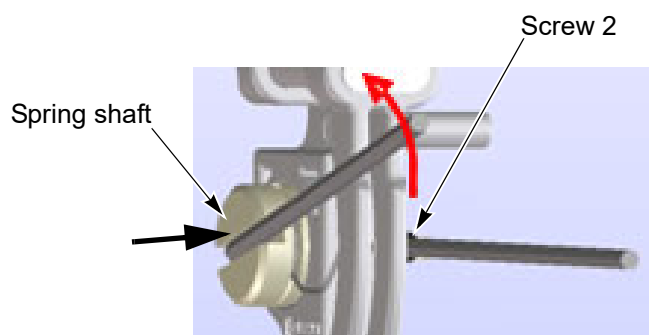

(4) When you want to tighten the thread tension, loosen the screw 2, and turn the spring shaft down.

Tighten the screw 2 while pushing the spring shaft to the right direction (the direction of black arrow in the figure below).

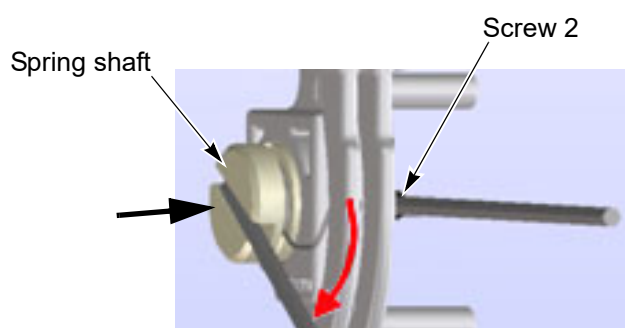

(5) When you want to return the thread tension to the standard value (the value at shipment from the factory), set the groove of the spring shaft horizontally.

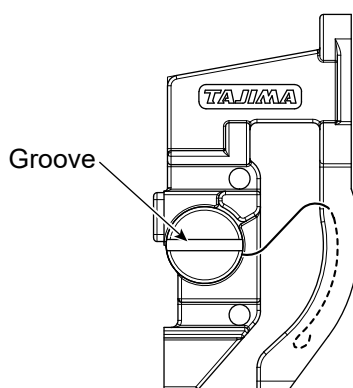

Chapter 12

Appendix

1. Specification of the machine	264
2. Function code	268
3. Electrical system diagram (TCMX-mixed type series).....	269
4. Electrical system diagram (TCMX-600 series)	271
5. Terminology	274

1

2

3

4

5

6

7

8

9

10

11

12

1. Specification of the machine

1-1. Power supply specifications

Since power spec. of the machine is specified clearly as shown below, use the machine under these conditions.

WARNING

 Since there is a danger of electric shock due to leak current, be sure to ground the earth cable of the machine. In addition, degree of grounding should be type D or higher (grounding resistance 100 ohms or less).

(1) Voltage, allowable voltage range: $\pm 10\%$ of the rated voltage

(2) Power consumption (max)

TCMX-600 series

Machine Type	Power consumption
TCMX-601	140 W
TCMX-618	1.7 kW

TCMX-mixed type series

Machine Type	Power consumption
TCMX-60915	1.6 kW

(3) Frequency: 50/60 Hz

(4) Insulation resistance: 10M ohms and larger (at 500 V Megger)

1-2. Ambient noise level

The ambient noise level of the machine is less than 85 db. (TCMX-601: less than 82 db)

(1) Measuring position

Higher value is adopted after measured at B and C. The height is measured at 1.6 m from the floor.

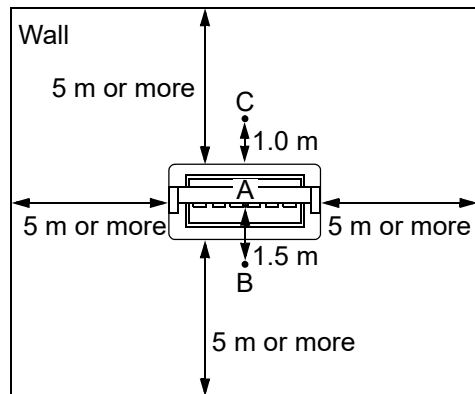

A: Position of needle location

(2) Working condition of the machine

Fabric is stretched on the border frame, and embroidery with satin stitches 4 mm in length will be executed.

(3) RPM

Maximum number of revolutions of the machine

(4) Measuring instrument

Conformity to IEC61672-1: 2002 Class 1

1-3. Machine weight

Since it is described on the spec. plate of the machine, please check.

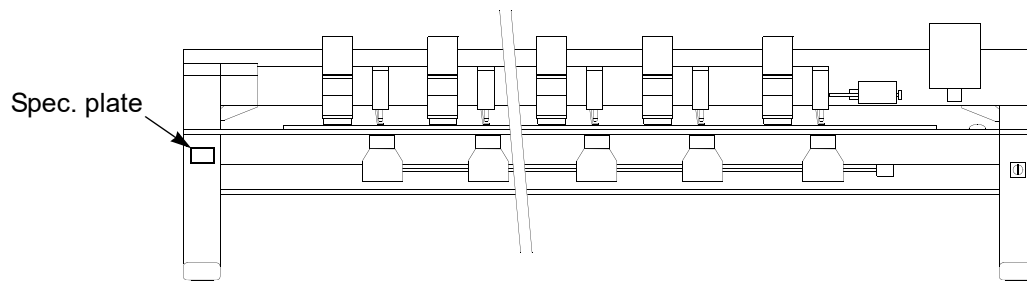

1-4. Switching of input voltage

Applicable model: TCMX-mixed type (L), TCMX-601

The following label (either one sheet, it differs depending on voltage spec.) is stuck on the power supply card of the machine. Only the machine model on which label No. 3 is stuck can be switched input voltage.

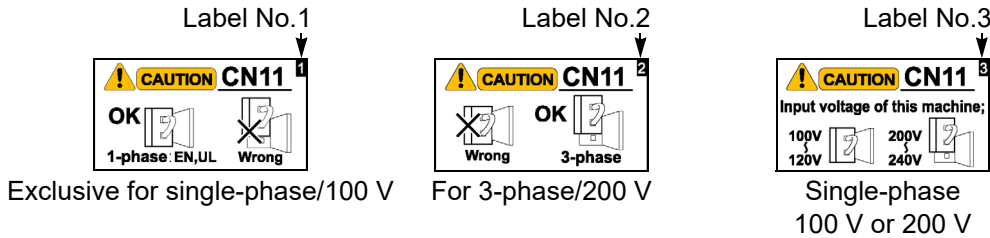

However, since the setting is performed according to your voltage spec. at shipment, it is not necessary to switch input voltage in usual usage. Perform switching of input voltage only in the following condition.

- (1) When the machine was moved for installation to the place whose voltage spec. is different from that at shipment
- (2) When you replace power supply card and connection of the connector (CN11) is different from your voltage spec.

How to switch

Change connection of the connector CN11 on the power supply card.

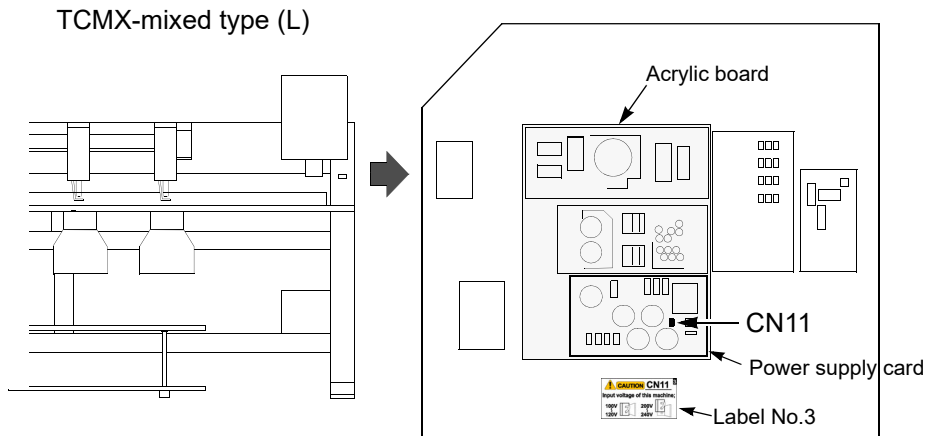

<Connection of CN11>

In case of 100 V series



In case of 200 V series



TCMX-601

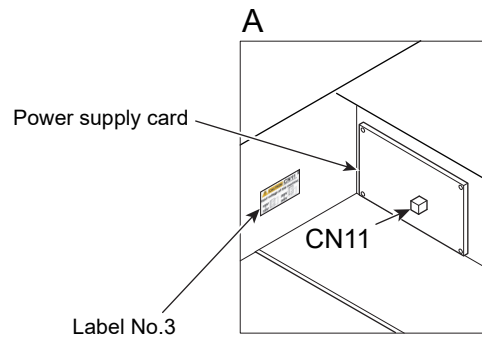
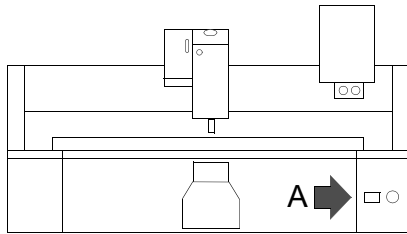

<Connection of CN11>

In case of 100 V series



In case of 200 V series



1
2
3
4
5
6
7
8
9
10
11
12

2. Function code

Function codes that can be edited by this machine

Function code	Function name	In case of storing design to a USB memory and selecting "T", data will be converted to the following function codes.
Stitch	Stitch	Stitch
Jump	Jump	Jump
COLOR	Color Change	Stop
ATH	Upper/Under Thread ATH	Jump
Up_ATH	Upper Thread ATH	
Tmp_Stop	Temporary Stop Stitch	Stop
Tmp_Stop_J	Temporary Stop Jump	
Low_S	Low Speed Start Stitch	Stitch
Low_E	Low Speed End Stitch	
Low_S_J	Low Speed Start Jump	Jump
Low_E_J	Low Speed End Jump	
Satin_S	Satin Stitch Start	Stitch
Satin_E	Satin Stitch End	
Offset	Auto Color Change Offset	
Sequin_S	Sequin Start	Sequin
Sequin_E	Sequin End	
Sequin_O	Sequin Output	Jump
Sequin_O_2	Sequin output 2	
S_Beads_S	Seed Beads Start	Sequin
S_Beads_E	Seed Beads End	
S_Beads_1	Seed Beads Output 1	Jump
S_Beads_2	Seed Beads Output 2	
Boring_S	Boring Start	Stitch
Boring_E	Boring End	
AFC_Feed	AFC frame feed	
End	End	End

3. Electrical system diagram (A3 size)

3-1. TCMX-mixed type

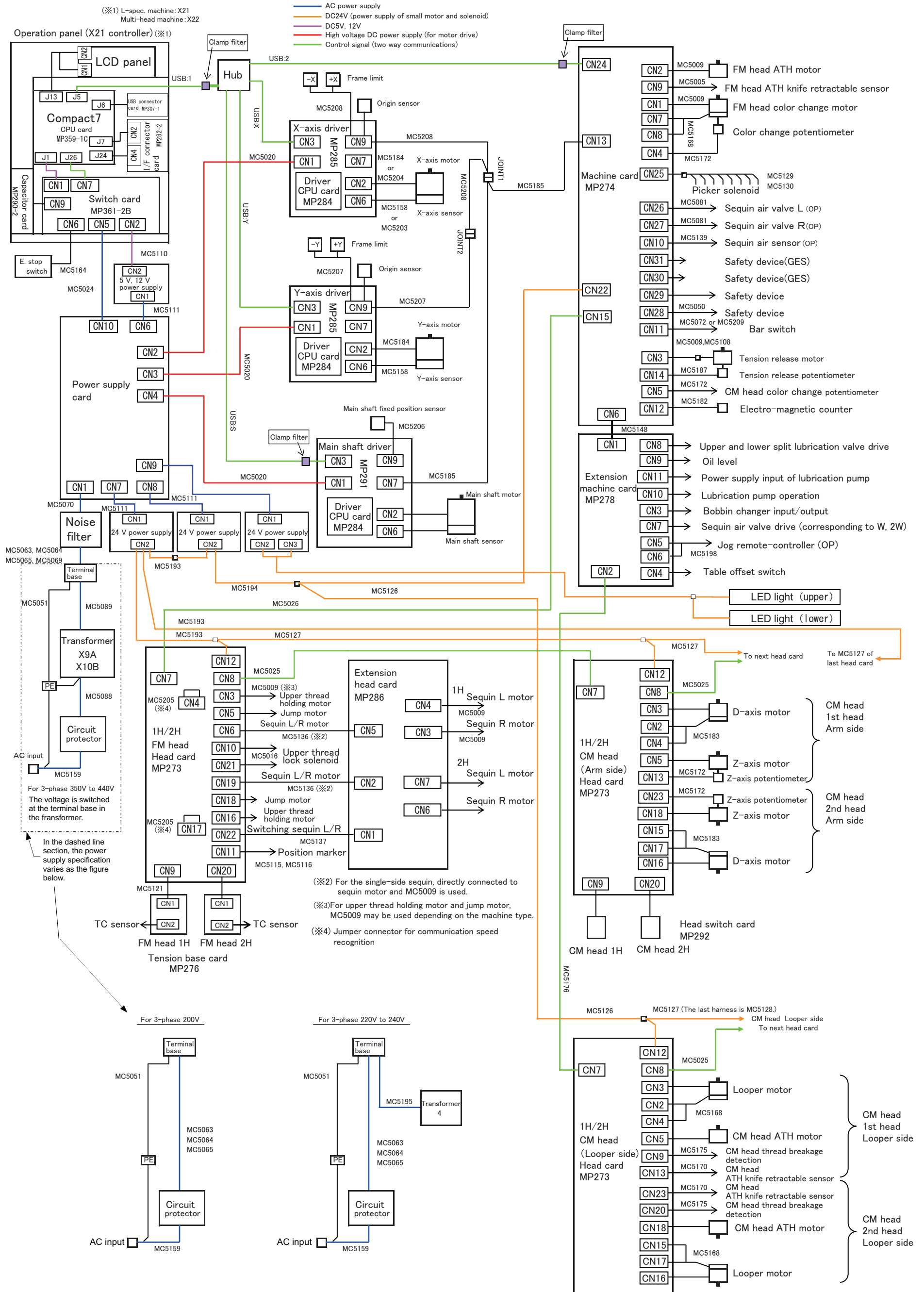

Operation panel interior connection for X22 controller

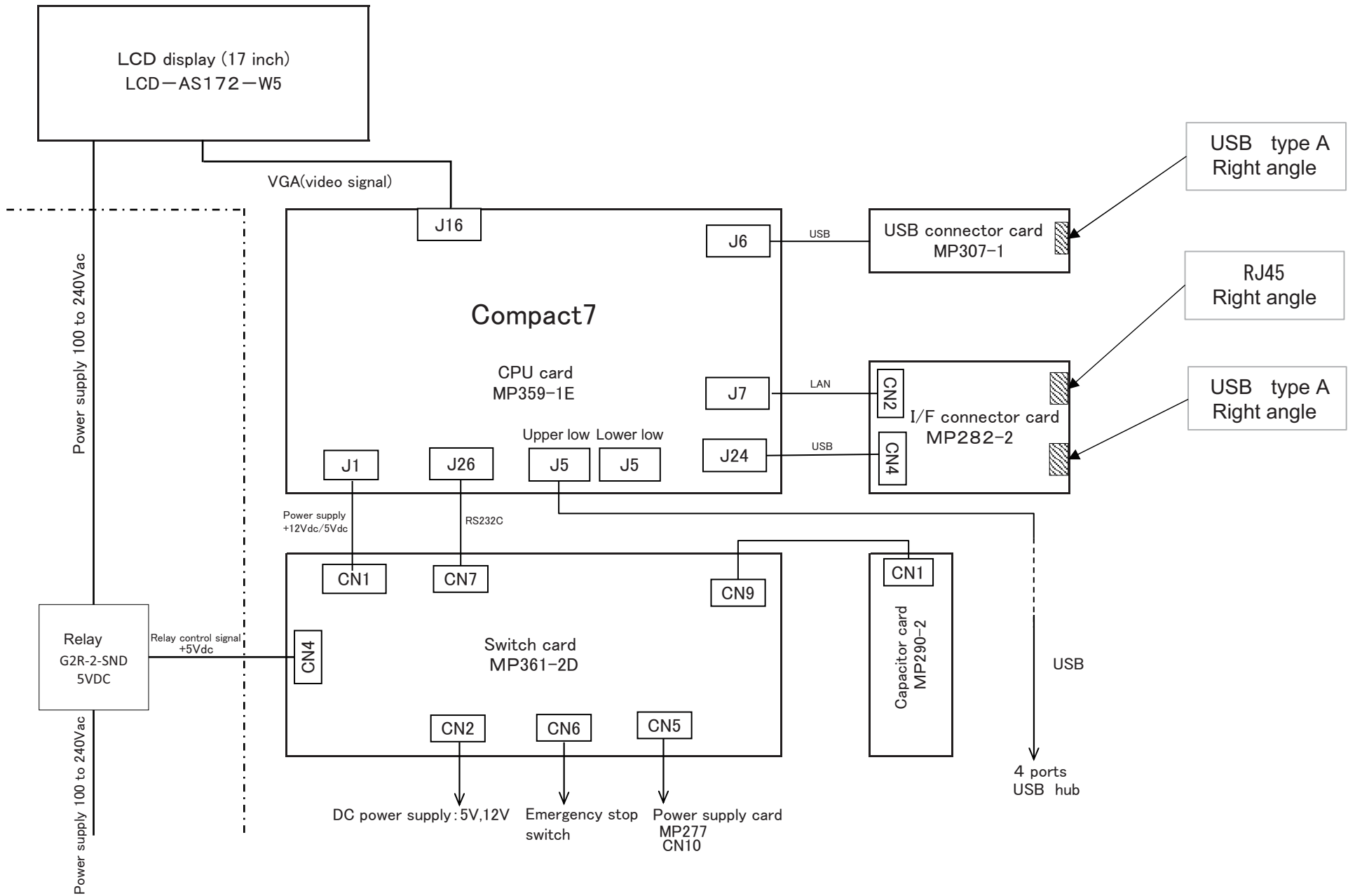

Operation panel interior connection for X21 controller

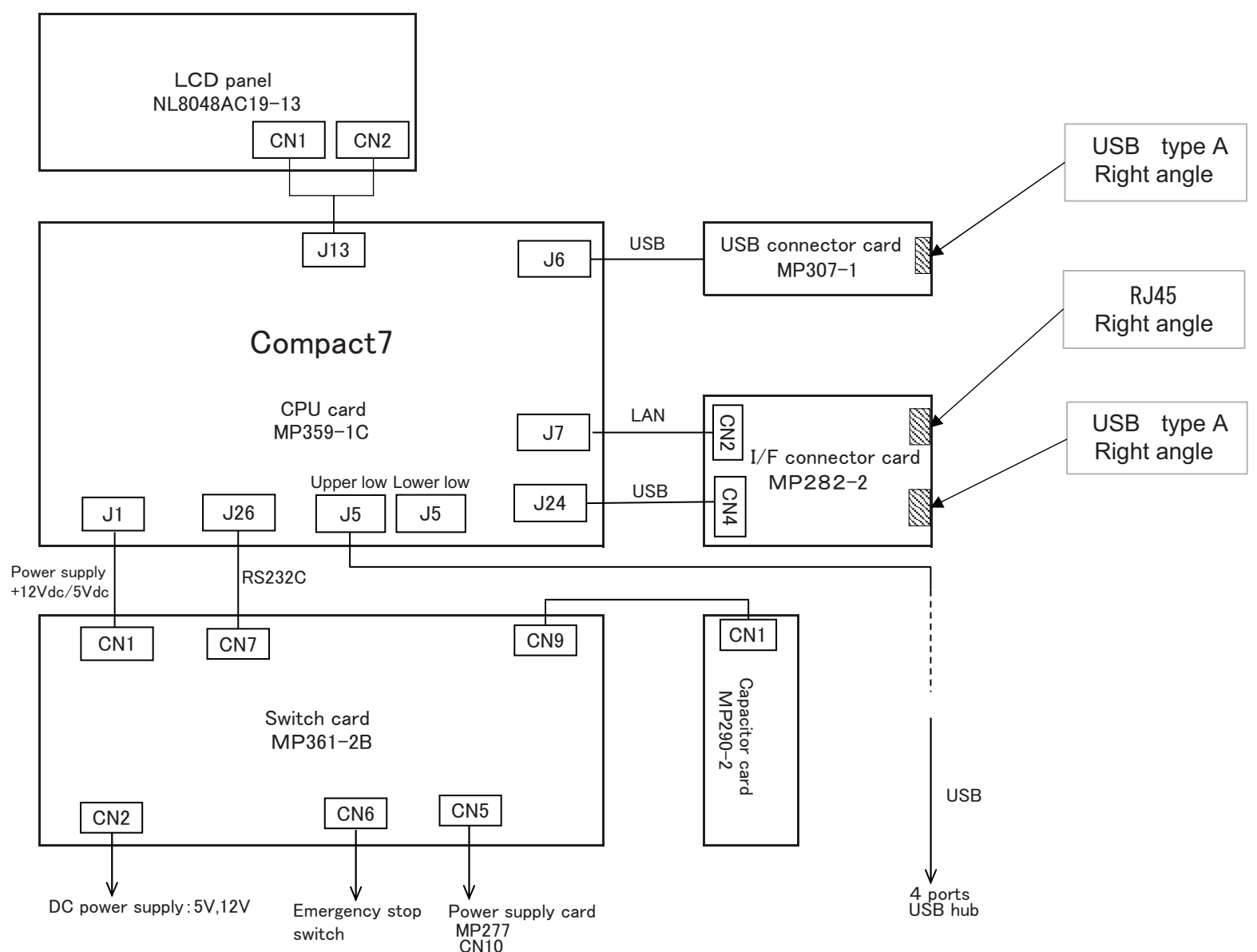

5. Terminology

The following terms apply to all common models. There might be a case where it does not correspond.

<p><A> Absolute origin An anchor point to calculate the current frame position (X: 0.0, Y: 0.0).</p> <p>ATH Abbreviation of Automatic Thread Trimming and Holding Device.</p> <p>Auto Jump To make a stitch divided into two stitches automatically when its stitch length exceeds the setting value. It is effective to prevent the slippage of the frame and the displacement of the design.</p> <p> Backlash A play (gap) generated to the drive system and/or around the frame by shock when a stitch returns (when frame drive is reversed). It may affect finish of sewing.</p> <p><C> Cleanup To remove a fine stitch included in design data to make before and after stitches absorb it. It is effective to reduce thread breakage.</p> <p>Condition data Operating condition of the machine included in the design data (Needle bar selection, data conversion, repeat, start position, automatic offset).</p> <p>CT0 File including information of needle bar selection and start position. It is necessary to handle TBF, CT0 and DGF as a set on a personal computer.</p> <p><D> Data set To set the design data in the memory of the machine to start the machine.</p> <p>D-axis Driving shaft to rotate sewing needle or nipple (TCMX series).</p>	<p>DGF File that indicates design image. It is necessary to handle TBF, CT0 and DGF as a set on a personal computer.</p> <p>Driver Control card to make the frame or main shaft drive. X-axis driver, Y-axis driver, main shaft driver etc. are included.</p> <p>DST Stitch data of Tajima ternary format. Data saving format is T.</p> <p><E> Excitation To keep frame motor drive. It is not possible to move the frame by hand during excitation.</p> <p><F> Fine stitch Short stitch such as it causes thread breakage. Stitch of which stitch length is 0.5mm or less.</p> <p>Fixed pitch movement Horizontal frame travel to the neighboring head by head interval.</p> <p>Fixed position Angle of the main shaft at which the main shaft motor stops (stop position).</p> <p>Frame Back To move the embroidery frame only to the direction where the stitches return with the needle bar(s) stopped.</p> <p>Function code Command code that controls general movements of the machine. All design data consists of function codes (Stitch, Jump, Color, etc.).</p> <p>Frame coordinates Frame position in embroidery space. It is indicated such as "X: -153.2, Y: +120.4".</p> <p>Frame Forward To move the embroidery frame only to the direction where the stitches advance with the needle bar(s) stopped.</p>
--	---

Frame Limit

Limit position that the frame can move (it is indicated by mark-off line on the table).

Frame origin

An anchor point to calculate the current frame position (X: 0.0, Y: 0.0).

Frame stepping

To move the embroidery frame only with the main shaft of the machine is stopped during embroidery.

<H>**Head group**

Function that assumes multiple heads as one head by grouping them. This enables large design embroidery or multi-colored embroidery of more colors than the number of needles per head.

<I>**Inching**

Movement to stabilize start of sewing by moving a needle bar slowly before the main shaft starts usual operation. It is executed before thread trimming to stabilize thread trimming.

<J>**Jump**

To make only the frame move in the state that needle bar does not move down during operation. It is possible to make a longer stitch than one stitch of the maximum length.

<M>**M-axis**

Drive shaft to rotate nipple or bobbin (TLMX series).

Main shaft brake (Weak Brake)

To hold the main shaft with the brake of the main shaft motor so that the main shaft does not rotate when it stops.

<O>**Offset start position (Offset position)**

A frame travel start position set by operation of automatic offset. A position to make the machine stand by to facilitate changing of frame and/or fabric by moving the frame to the front automatically in the middle or at the end of embroidering.

<P>**Parameter**

Setting item that decides the working condition of the machine.

Pseudo-fixed position (stop at the lower dead point)

To stop the machine with the needle stuck in the cloth at the end of embroidery. Moving the frame in this condition will enable consecutive embroidery.

<R>**Return Stitches**

Tie stitch to be executed at start of sewing (stitch to prevent mis-stitching at the start).

Running stitch

Decorative stitch of straight line or curved line only.

<S>**Satin Stitch**

Repeated zigzag stitches. It is mainly used for hem of applique, logo, mark, flower design etc.

Sequin needle

Needle that sews sequins with sequin device. It indicates the first needle or the last needle.

Side Kick

Name of the network application software manufactured by Pulse Microsystems Ltd. It is possible to input the design data to the machine by wireless LAN as the main function.

Step

The section divided by a color change code in the design data. The first section is called step 1, and the next section is called step 2.

<T>**Table offset**

To move the frame to the rear direction temporarily to facilitate threading. It is mainly effective when the frame is positioned at the table cut section.

Tatami stitch

Stitch to fill in a certain amount of area. It is mainly used for a big logo, background, underlay etc.

TBF

Stitch data of Tajima binary format. Data saving format is T2. It can hold many more function codes compared to DST. It is necessary to handle TBF, CT0 and DGF as a set on a personal computer.

TCF

Data integrating TBF, CT0 and DGF. Integration facilitates handling of design data. Data saving format is T3.

Tie Stitch

Tie stitch to be executed before thread trimming (stitch to prevent fray).

<X>**X-axis drive system**

Drive system to make the embroidery frame move in the horizontal (X) direction.

X data

Data to make the embroidery frame move in the horizontal (X) direction. It is indicated by moving direction (code: +/-) and value (mm).

<Y>**Y-axis drive system**

Drive system to make the embroidery frame move in the vertical (Y) direction.

Y data

Data to make the embroidery frame move in the vertical (Y) direction. It is indicated by moving direction (code: +/-) and value (mm).

<Z>**Zigzag cord needle**

Needle that sews cord with zigzag cording device. It indicates the first needle or the last needle.

Z-axis

Driving shaft to change needle height (TCMX series).

A	
A.S. after Auto Data Set	125
Adjustment of Snap-fit middle thread guide	258
Air Pressure Sensor	221
Ambient noise level	265
Auto Jump	129
Auto M-axis Power-ON Restore	99
Auto Origin Return	175
Automatic Offset	176
B	
Backlash	126
Bar switch	72
Bobbin changer	212
C	
Changing design name	188
Changing folder name	190
Cleaning	246
Cleanup	132
Color change speed	139
Condition data	33
Copy a design	186
Cording device	209
D	
Data Conversion	120
Data conversion for sequin output	222
Data Edit "Delete"	148
Data Edit "Insert"	112, 144
Data Edit "Modify"	141
Data Input LAN	46
Data Input USB	43
Data Setting	50
D-axis Origin Return	85
Decision of the design start position	60
Design sort "in memory"	192
Design sort "USB"	198
E	
Emergency stop switch	18
F	
Folder layer	43, 50
Frame Back	73, 162
Frame Back Function	91
Frame Drive Adjustment	136
Frame Forward	73, 162
Frame origin memory	172
Frame Travel Speed	140
Function code	268
G	
Greasing	253
I	
Inspection, Repair	257
J	
Jog remote-controller	21
Jump code combination	138
Jump Convert	111
K	
KB-2M	209
L	
LAN cable	17
LAN port	17
Language	157
Looper Fixed Position Return	86
Lubrication	249
M	
Main screen	28
Main Shaft Inching	138
Manual Color Change	102
Manual frame travel	62
Manual Head Selection	103
Manual M-axis Origin Return	94
Manual M-axis Power-ON Restore	95
Manual Needle Height Selection	84
Manual Offset	169
Manual Stitch Type Selection	88
Manual Stop at Lower Dead Point	159

Manual Thread Trimming	104	Start point of design	34
Max. Revolution Limit	116, 117	Step	53
Maximum RPM	67	Stop at Lower D.Point	119
M-axis Origin Offset	96	Stop factor	228
M-axis Retract Position	97		
Memory Delete	184	T	
Minimum RPM	115	table offset position	181
Misreading by bar code reader	49	Table offset switch	19
Movement of design	185	Tension base switch	70
		Terminology	274
N		Thread breakage indicator lamp	69, 70
Name of each part	10	Thread Management After Trimming	90
Needle Bar Color	155	Thread passing	38
Needle bar operation	61	To change color automatically	57
Needle bar suspension lever	71	To change frame type	168
Network	204	To excite the motor	239
		To perform Frame Back or Frame Forward in Stop code	163
O		To rotate M-axis by manual operation	93
Offset mark	54	To specify number of stitches to execute	163
One-touch middle thread guide	261	To start operation automatically	57
		To switch Frame Back / Frame Forward	162
P		To turn ON the power	37
PH-C120	23	Total Stitch Counter	154
PH-C70	23	Trace	65
Power resume	171	Trouble examples and Corrective actions	240
Power supply specifications	264		
Power switch	36	U	
Preset Halt	118	UBC II	212
		Upper Thread Lock Timing	135
R		USB "Save"	194
Registration of a design into the machine memory	43	USB Delete	196
Repeat	122	USB memory	16
Return the frame after manual frame travel	170		
Return to the offset origin	180	W	
		Warning labels	6
S		weak brake	158
Satin Stitch	127		
Saving format of the design	44		
Setting and resetting of password	151		
Setting in Units of Needle Bar	130		
Setting to prevent a fray of the thread	89		
Snap-fit middle thread guide	258		
Software Version	156		

1st Edition August, 2007

31st Edition June, 2021

■ Manufactured by : **TISM Co.,Ltd.**

NO.1800, Ushiyama-cho, Kasugai, Aichi-pref., 486-0901, JAPAN
TEL.81-568-33-1161 FAX.81-568-33-1191

■ Distributed by : **Tajima Industries Ltd.**

19-22, Shirakabe, 3-chome, Higashi-ku, Nagoya, 461-0011, JAPAN
TEL.81-52-932-3444 FAX.81-52-932-2457

Copy, reprint, or modification of all or any part of this manual without permission is prohibited.

THE TAJIMA GROUP

<http://www.tajima.com>

Tajima Industries Ltd.

19-22, Shirakabe, 3-chome, Higashi-ku, Nagoya, 461-0011, JAPAN
TEL.81-52-932-3444 FAX.81-52-932-2457

TISM Co.,Ltd.

NO.1800, Ushiyama-cho, Kasugai, Aichi-pref., 486-0901, JAPAN
TEL.81-568-33-1161 FAX.81-568-33-1191