

PARTS LIST

TMBP-SC

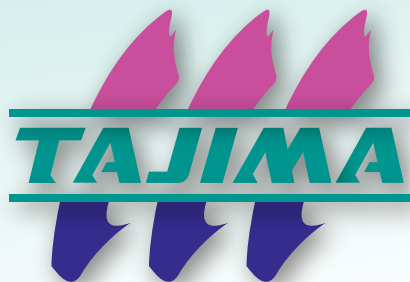

Table of Contents

● GENERAL VIEW	
● FRAMING.....	E2-1
● MAIN SHAFT DRIVE SYSTEM.....	E2-2
● CYLINDER BED 1.....	E2-3-1
● CYLINDER BED 2.....	E2-3-2
● COLOR CHANGE SYSTEM.....	E2-4
● ARM 1.....	E2-5-1
● ARM 2.....	E2-5-2
● ARM 3.....	E2-5-3
● NEEDLE BAR CASE 1.....	E2-6-1
● NEEDLE BAR CASE 2.....	E2-6-2
● X-AXIS DRIVE SYSTEM.....	E2-7
● Y-AXIS DRIVE SYSTEM.....	E2-8
● TENSION BASE.....	E2-9
● THREAD STAND.....	E2-10
● OPERATION PANEL.....	E2-11
● ELECTRICAL PARTS.....	E2-12
● TABLE, BORDER FRAME (OPTION).....	E2-13
● SIGNAL TOWER, STAND (OPTION).....	E2-14
● X-EXTENSION UNIT 1 (OPTION).....	E2-15-1
● X-EXTENSION UNIT 2 (OPTION).....	E2-15-2

Part Nos. of screws, nuts, washers etc. are listed at the end of volume.

*Regarding the part number that contains description of @, the part differs depending on model, spec. etc.

*When you place an order of such a part, please also inform us of your model, embroidery space and manufacturing number of the machine.

Ex.	TMBP-S1501C	360 x 500S	No.E2X01234
	[Model]	[Emb. Space]	[Mfg. No.]

GENERAL VIEW

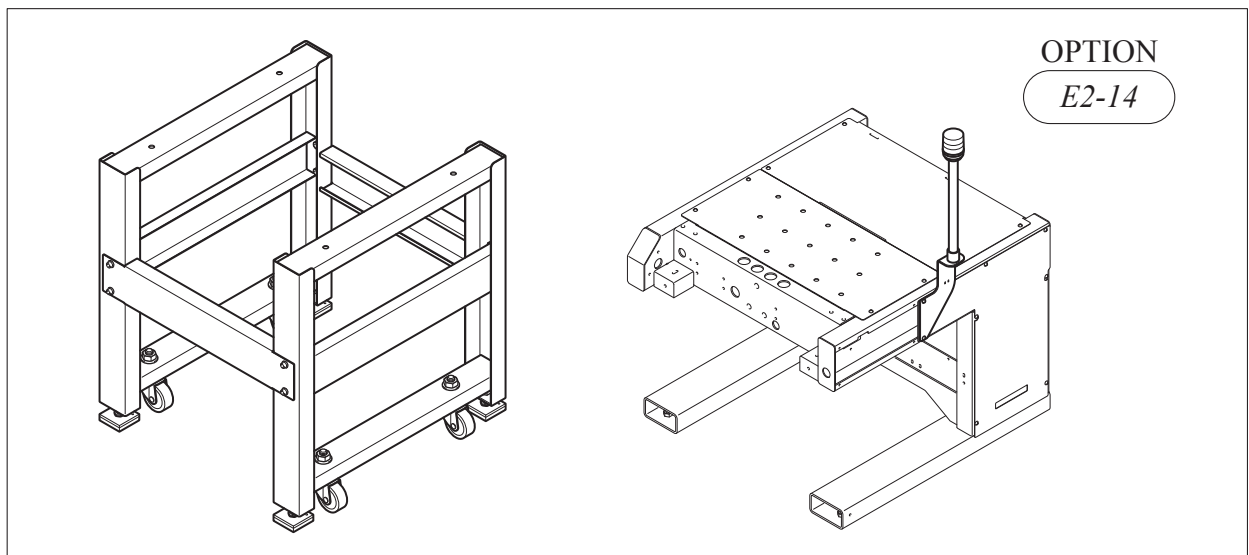
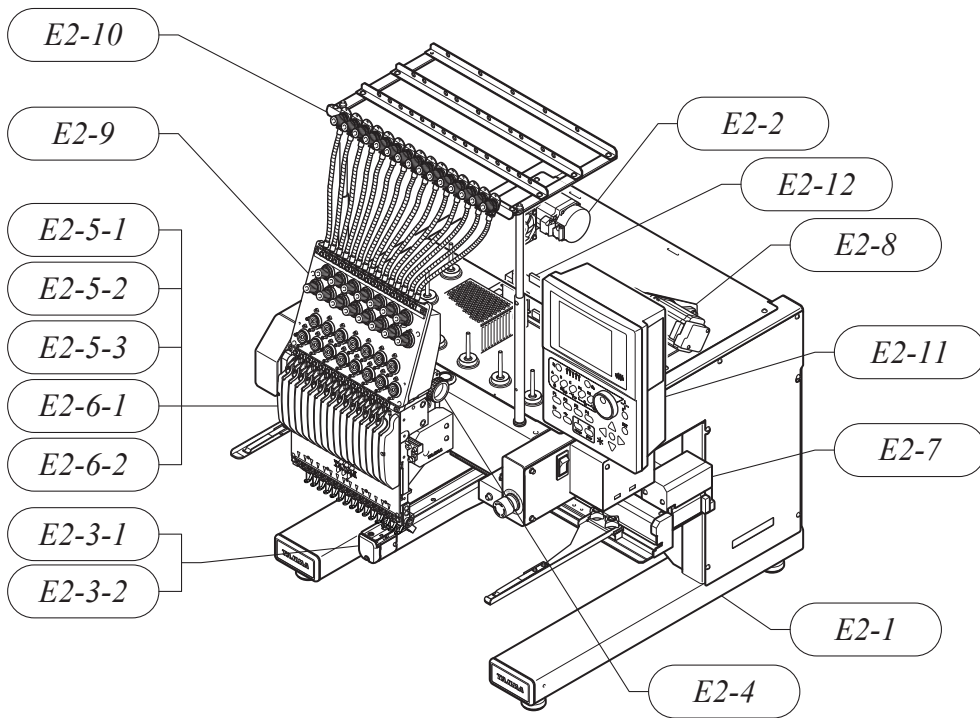
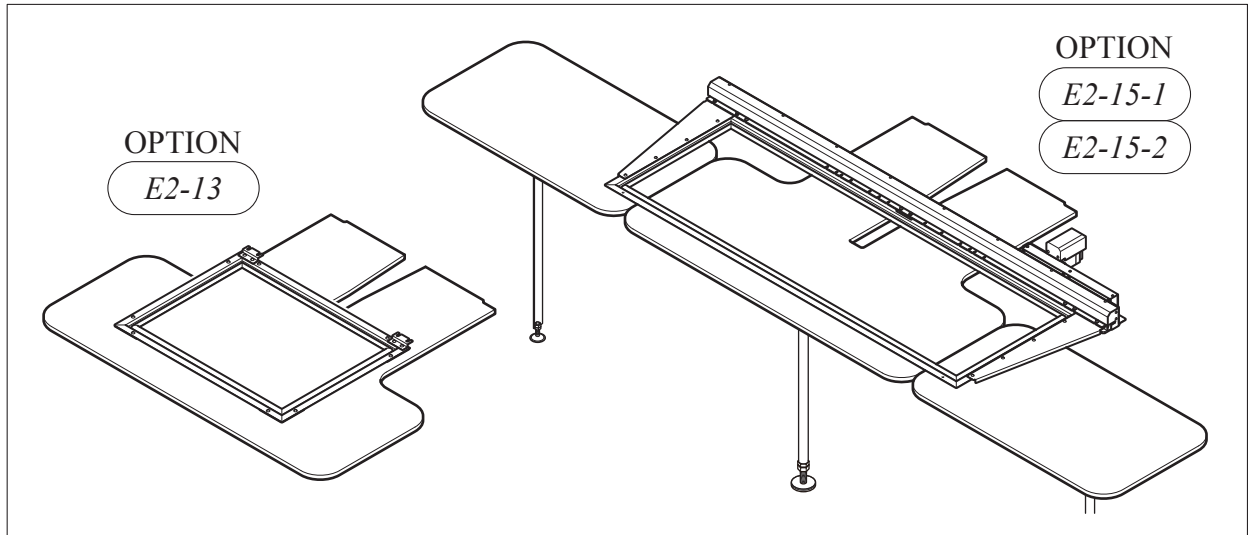

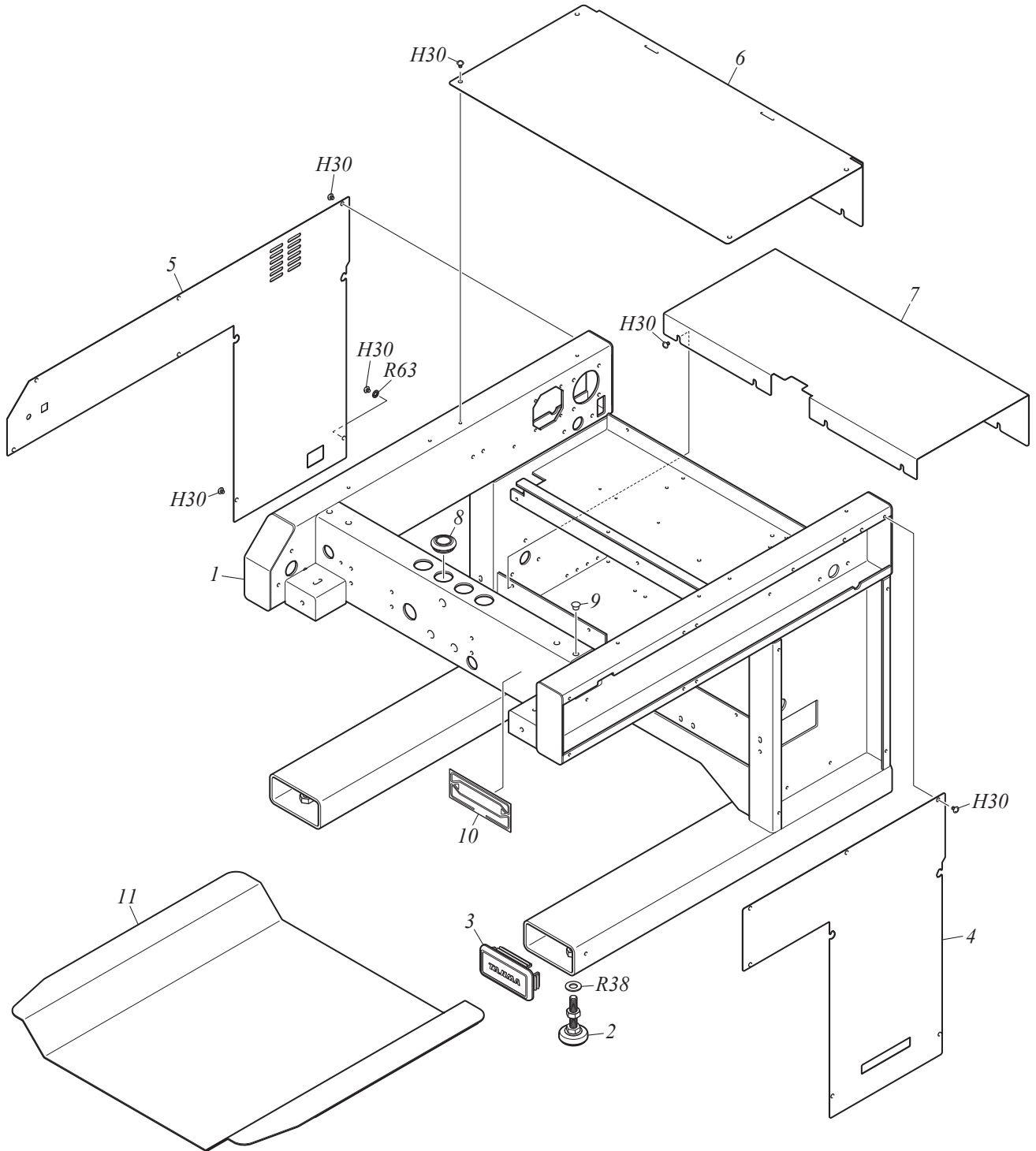

FRAMING

E2-1

No.	Part Name	Part No.	Remark
1	STAND :0001/036*500S	NE115001@040	
2	RUBBER BASE ADJUSTER :M10	614300240000	
3	COVER :STAND BASE	030440610010	
4	COVER :RIGHT-SIDE BOX	03044065@000	
5	COVER :LEFT-SIDE BOX	03044066@000	
6	COVER :STAND :UPPER	03044067@010	
7	COVER :STAND :LOWER	03044068@000	
8	GROMMET WITH FILM :26A	644500210000	
9	MULTI-PURPOSE CAP :KD-771-65I	617500080000	
10	MAIN NAME PLATE :TMBP-SC	14E2100@0010	
11	TRAY :STAND[S]	0L3110160S00	Option
12			
13			
14			
15			
16			
17			
18			
19			
20			
21			
22			
23			
24			
25			
26			
27			
28			
29			
30			
31			
32			
33			
34			
35			
36			
37			
38			
39			
40			
41			
42			
43			
44			
45			
46			
47			
48			
49			
50			

Note: As for parts with mark @, please follow our instructions on Table of Contents in your parts order.

(YK05)

MAIN SHAFT DRIVE SYSTEM

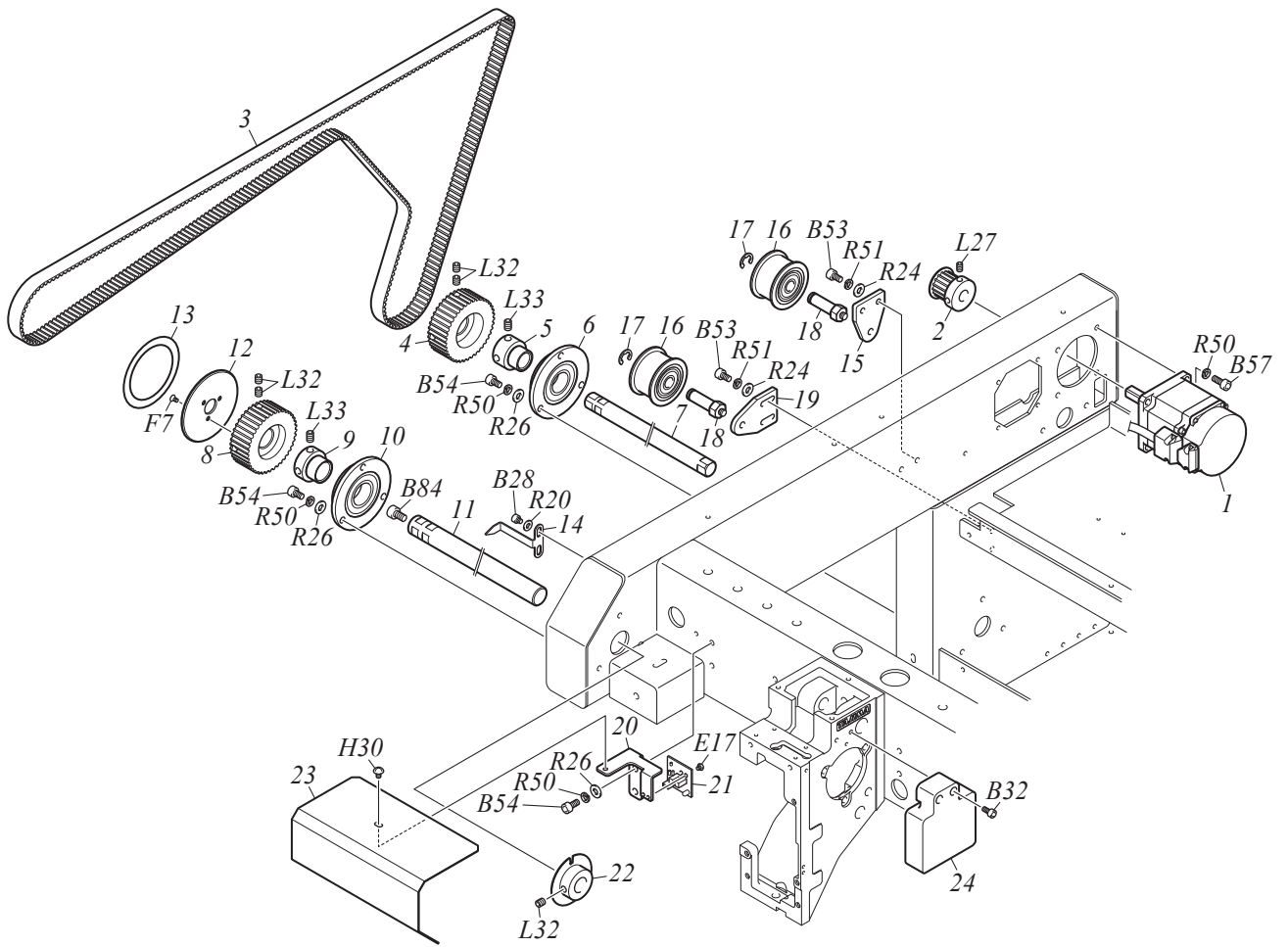

MAIN SHAFT DRIVE SYSTEM

E2-2

No.	Part Name	Part No.	Remark
1	SERVO MOTOR :188W	0J6301700000	
2	TIMING PULLEY :MAIN SHAFT :W15-16[S]	501430150S00	
3	TIMING BELT :SPTG :W15-S5M1680/GB	623200500000	
4	TIMING PULLEY :B :W15-40	50143303B000	
5	BEARING COLLAR :15MM DIA.	502715040010	
6	BEARING CASE :NO.2 :20MM DIA.[S]	508220060S00	
7	ROTARY HOOK SHAFT :15P*340	QS3102010000	
8	TIMING PULLEY :B :W15-40	50143305B000	
9	BEARING COLLAR :18MM DIA.	502718010010	
10	BEARING CASE :NO.2 :22MM DIA.[S]	508222020S00	
11	MAIN SHAFT :18P*347.5	QS3101010000	
12	BASE :ANGLE INDICATOR	040120260000	
13	ANGLE INDICATOR	040420230010	
14	POINTER	040410220000	
15	BASE :IDLER :B	04015003B000	
16	FLAT PULLEY :40MM DIA.[S]	501902050S00	
17	E-RING :7MM DIA.	611100100000	
18	SCREW WITH ROLLER PIN :NO.3 :M6	514306030000	
19	BASE :IDLER	040150030000	
20	BRACKET :SENSOR	040370100000	
21	CARD :PHOTO-INTERRUPTER	0J4204500000	
22	ROTATING DETECTING PLATE[S]	040360050S10	
23	SHAFT COVER	17018008@010	
24	HEAD COVER :SINGLE HEAD M/C :R	080430310000	
25			
26			
27			
28			
29			
30			
31			
32			
33			
34			
35			
36			
37			
38			
39			
40			
41			
42			
43			
44			
45			
46			
47			
48			
49			
50			

Note: As for parts with mark @, please follow our instructions on Table of Contents in your parts order.

(YK05)

CYLINDER BED 1

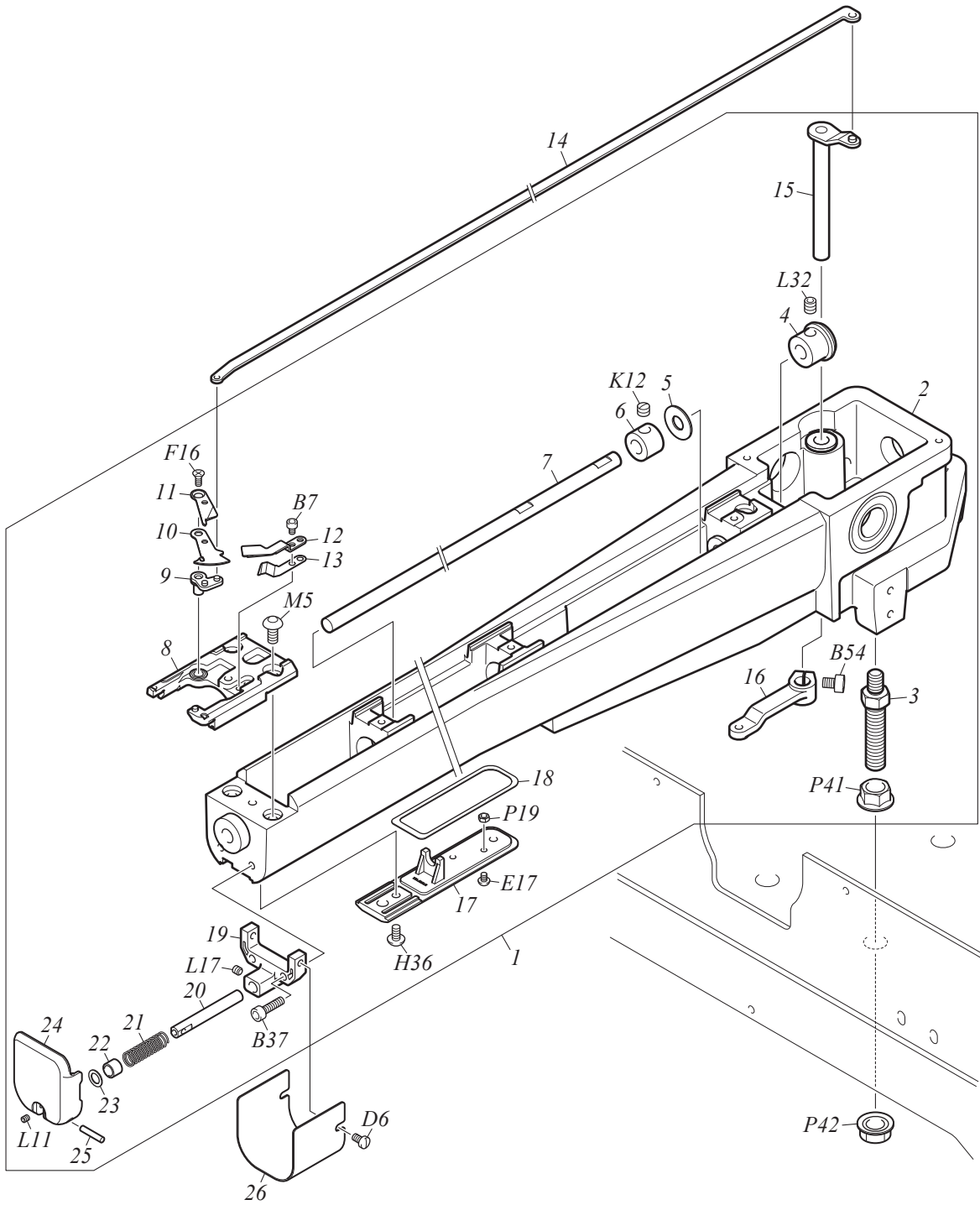

CYLINDER BED 1

E2-3-1

No.	Part Name	Part No.	Remark
1	LONG CYLINDER BED[A]	050170070A00	
2	LONG CYLINDER BED[S]	050170030S10	
3	ROTARY HOOK BASE STUD	050330330000	
4	SPIRAL BEVEL GEAR :NO.1 :14T	506514030000	
5	PLAIN WASHER :7.94*19*T0.8	519108030000	
6	STOPPER COLLAR :7.94MM DIA.	502107020000	
7	SHAFT :ROTARY HOOK :7.94MM DIA.	050330550000	
8	NEEDLE PLATE BRACKET[S]	050330840S00	
9	LEVER SHAFT :KNIFE[S]	050321790S00	
10	THREAD SEPARATING PLATE :PICKER FREE	050321770000	
11	MOVABLE KNIFE :DIRECT MOVEMENT 2-BLADE TYPE	050321780000	
12	FIXED KNIFE :DIRECT MOVEMENT 2-BLADE TYPE	050321760000	
13	UNDER THREAD PRESSER	050321750000	
14	CONNECTING PLATE :KNIFE	050321810000	
15	LEVER SHAFT :KNIFE CONNECTING PLATE[S]	050320850S20	
16	LEVER :KNIFE CONNECTING PLATE SHAFT	050321000000	
17	BASE :SOLENOID	050321450000	
18	RUBBER PACKING	050321560000	
19	BASE :ROTARY HOOK COVER	050330820000	
20	STRAIGHT PIN :NO.2 :6MM DIA.	503102360000	
21	COMPRESSION SPRING :0.6MM DIA.	507606110000	
22	COLLAR :NO.1 :6MM DIA.	502506060000	
23	PLAIN WASHER :6*9.5*T0.5	519106043020	
24	ROTARY HOOK COVER	050330830000	
25	STRAIGHT PIN :NO.1 :3MM DIA.	503101100000	
26	COVER :NEEDLE PLATE BRACKET	050330810010	
27			
28			
29			
30			
31			
32			
33			
34			
35			
36			
37			
38			
39			
40			
41			
42			
43			
44			
45			
46			
47			
48			
49			
50			

Note: As for parts with mark @, please follow our instructions on Table of Contents in your parts order.

(ZJ03)

CYLINDER BED 2

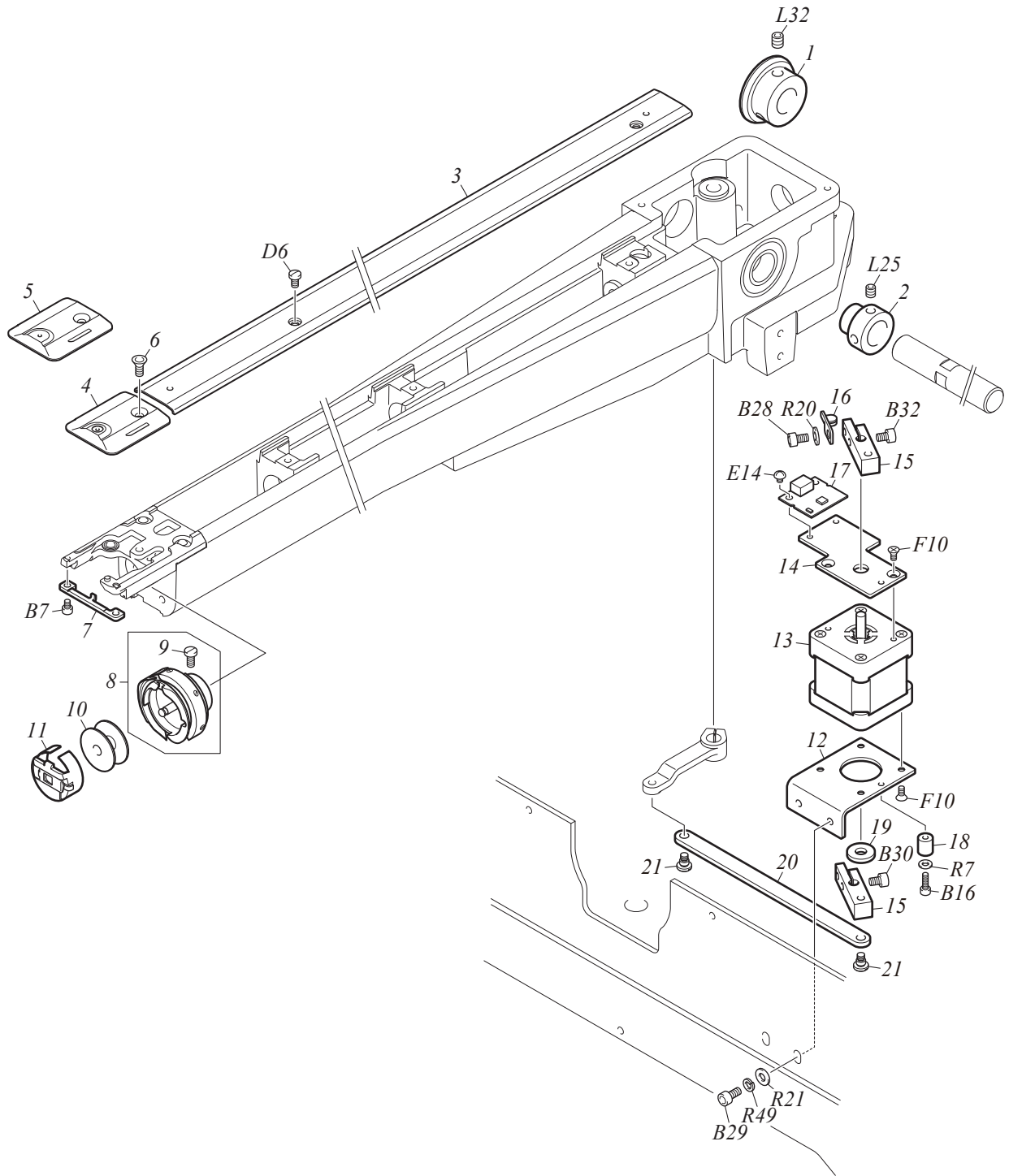

CYLINDER BED 2

E2-3-2

No.	Part Name	Part No.	Remark
1	SPIRAL BEVEL GEAR :NO.1 :28T	506528030000	
2	BEARING COLLAR :15MM DIA.	502715080000	
3	COVER :CYLINDER BED :FRONT	050330700000	
4	NEEDLE PLATE	05034063@000	
5	NEEDLE PLATE	9A060280@000	Without Dent
6	HEXAGON SOCKET HEAD COUNTERSUNK SCREW :M4*10	S125041001MZ	
7	ROTARY HOOK SUPPORT	050330660000	
8	ROTARY HOOK :KHS12-RYPTFS2OE	050230090020	
9	ROTARY HOOK SET SCREW :11/64*7.2	050290020000	
10	BOBBIN :REGULAR ROTARY HOOK	050260010020	
11	BOBBIN CASE :REGULAR ROTARY HOOK :STANDARD	050240150010	
12	BASE :ATH MOTOR	050321580000	
13	PULSE MOTOR :42MM SQUARE :DOUBLE-END	0J6106200000	
14	BASE :SENSOR	050321590000	
15	LEVER :ATH	050320100000	
16	SENSOR PLATE :NO.1	050320110000	
17	CARD :MAGNETIC SENSOR A	0J4204400000	
18	COLLAR :NO.1 :3MM DIA.	502503110000	
19	PLASTIC WASHER :6*15*T2.5	519206020000	
20	CONNECTING PLATE :ATH DRIVE ARM	050320430000	
21	STEPPED SCREW :NO.1 :M4*6.7	512104100040	
22			
23			
24			
25			
26			
27			
28			
29			
30			
31			
32			
33			
34			
35			
36			
37			
38			
39			
40			
41			
42			
43			
44			
45			
46			
47			
48			
49			
50			

Note: As for parts with mark @, please follow our instructions on Table of Contents in your parts order.

(ZJ03)

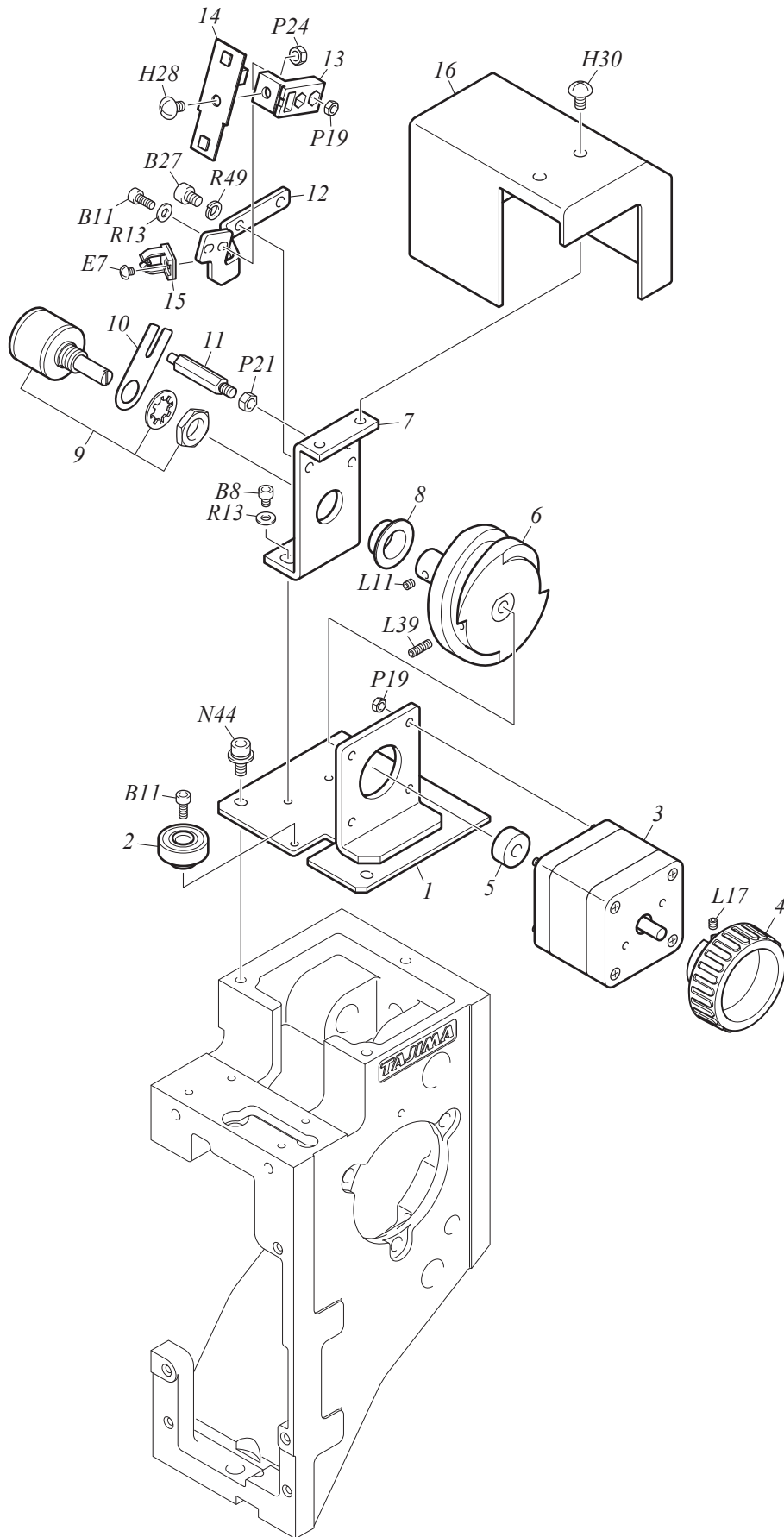

COLOR CHANGE SYSTEM

E2-4

No.	Part Name	Part No.	Remark
1	BASE :CHANGE MOTOR	070110340020	
2	ROLLER PIN[S]	080290040S10	
3	PULSE MOTOR :42MM SQUARE :DOUBLE-END[T]	0J6110700T10	
4	KNOB :B	08052001B010	
5	COLLAR :NO.1 :5.1MM DIA.	502551010010	
6	CAM :CHANGE[S]	070110480S00	
7	BEARING CASE :CHANGE CAM	070110370010	
8	OIL-BUSHING :NO.2 :MB0206-20FDU	638100240000	
9	POTENTIOMETER	640900010001	
10	BRACKET :POTENTIOMETER	0C0420020010	
11	STUD :NO.4 :M4-27.5	505404030020	
12	SENSOR ARM	0C0230420010	
13	BASE :CARD	0C0230410010	
14	CARD :TC SENSOR :TCS131	0J2603200000	
15	MINI CLAMP :MB-3	644100200000	
16	COVER :CHANGE	070110050010	
17			
18			
19			
20			
21			
22			
23			
24			
25			
26			
27			
28			
29			
30			
31			
32			
33			
34			
35			
36			
37			
38			
39			
40			
41			
42			
43			
44			
45			
46			
47			
48			
49			
50			

Note: As for parts with mark @, please follow our instructions on Table of Contents in your parts order.

(YK11)

ARM 1

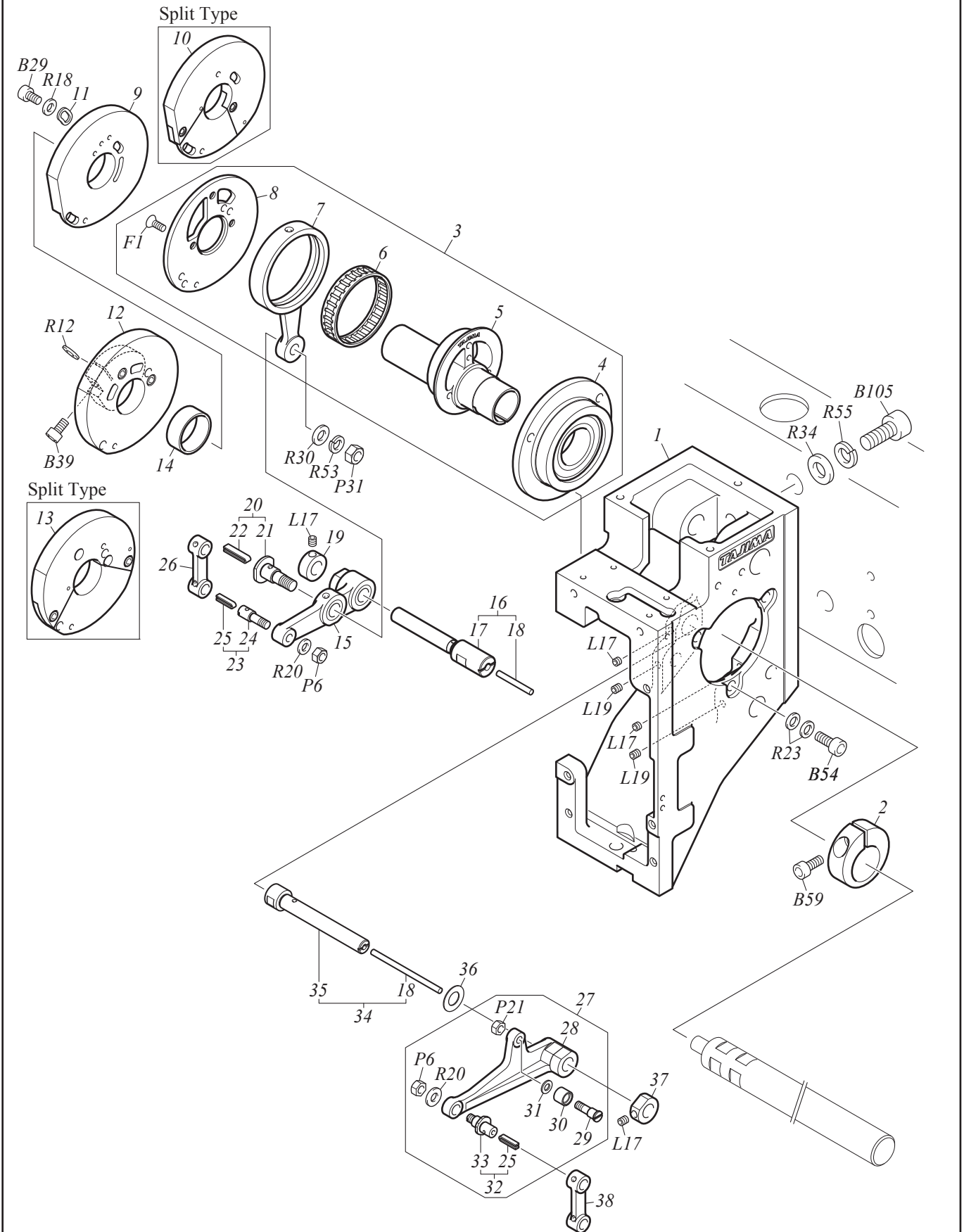

ARM 1

E2-5-1

No.	Part Name	Part No.	Remark
1	HEAD :STANDARD	080120070010	
2	TIGHTENING COLLAR :21MM DIA.	502221010010	
3	CAM :NEEDLE BAR[A]	080220010A00	
4	BEARING CASE :NO.2 :22MM DIA.[S]	508222010S00	
5	CAM :NEEDLE BAR	080220010000	
6	NEEDLE CAGE :KT404310NE01B2	634400070001	
7	CONNECTING ROD :51.7	080220040000	
8	BASE :TAKE-UP LEVER CAM	080220400000	
9	CAM :TAKE-UP LEVER :REGULAR ROTARY HOOK	080220060010	
10	CAM :SPLIT TYPE :TAKE-UP LEVER FOR 47 :REGULAR ROTARY HOOK[A]	9A0802700A00	
11	WASHER :CAM	080220180000	
12	CAM :PRESSER FOOT[A]	080220021A20	
13	CAM :PRESSER FOOT :SPLIT TYPE	9A0802400010	
14	COLLAR :NO.1 :21MM DIA.	502521010000	
15	LEVER :NEEDLE BAR[S]	080230050S10	
16	STEPPED PIN :NO.4[S]	503204070S10	
17	STEPPED PIN :NO.4	503204070010	
18	WICK :3P*61	080240230000	
19	STOPPER COLLAR :8MM DIA.	502108020010	
20	STEPPED SCREW :NO.2 :M6*13[S]	512206010S10	
21	STEPPED SCREW :NO.2 :M6*13	512206010010	
22	WICK :3.5*1*34	080240140000	
23	SCREW WITH PIN :NO.3 :11/64-7.7[A]	513354020A10	
24	SCREW WITH PIN :NO.3 :11/64-7.7	513354020010	
25	WICK :2.5*1*22	080240120010	
26	CONNECTING ROD	080230210000	
27	LEVER :DRIVE :PRESSER FOOT :45	U8K000000100	
28	LEVER :PRESSER FOOT[S]	080230140S50	
29	STEPPED SCREW :NO.1 :M4*5.3	512104160020	
30	ROLLER :5*8*5	515105020010	
31	PLAIN WASHER :4*7.5*T0.8	519104060000	
32	SCREW WITH ROLLER PIN :NO.4 :11/64E[S]	514454020S00	
33	SCREW WITH ROLLER PIN :NO.4 :11/64E	514454020000	
34	STEPPED PIN :NO.4[S]	503204030S00	
35	STEPPED PIN :NO.4	503204030020	
36	PLAIN WASHER :8*15*T0.5	519108050000	
37	STOPPER COLLAR :8MM DIA.	502108050010	
38	CONNECTING ROD :26	080230400000	
39			
40			
41			
42			
43			
44			
45			
46			
47			
48			
49			
50			

Note: As for parts with mark @, please follow our instructions on Table of Contents in your parts order.

(YK11)

12, 15-Needle

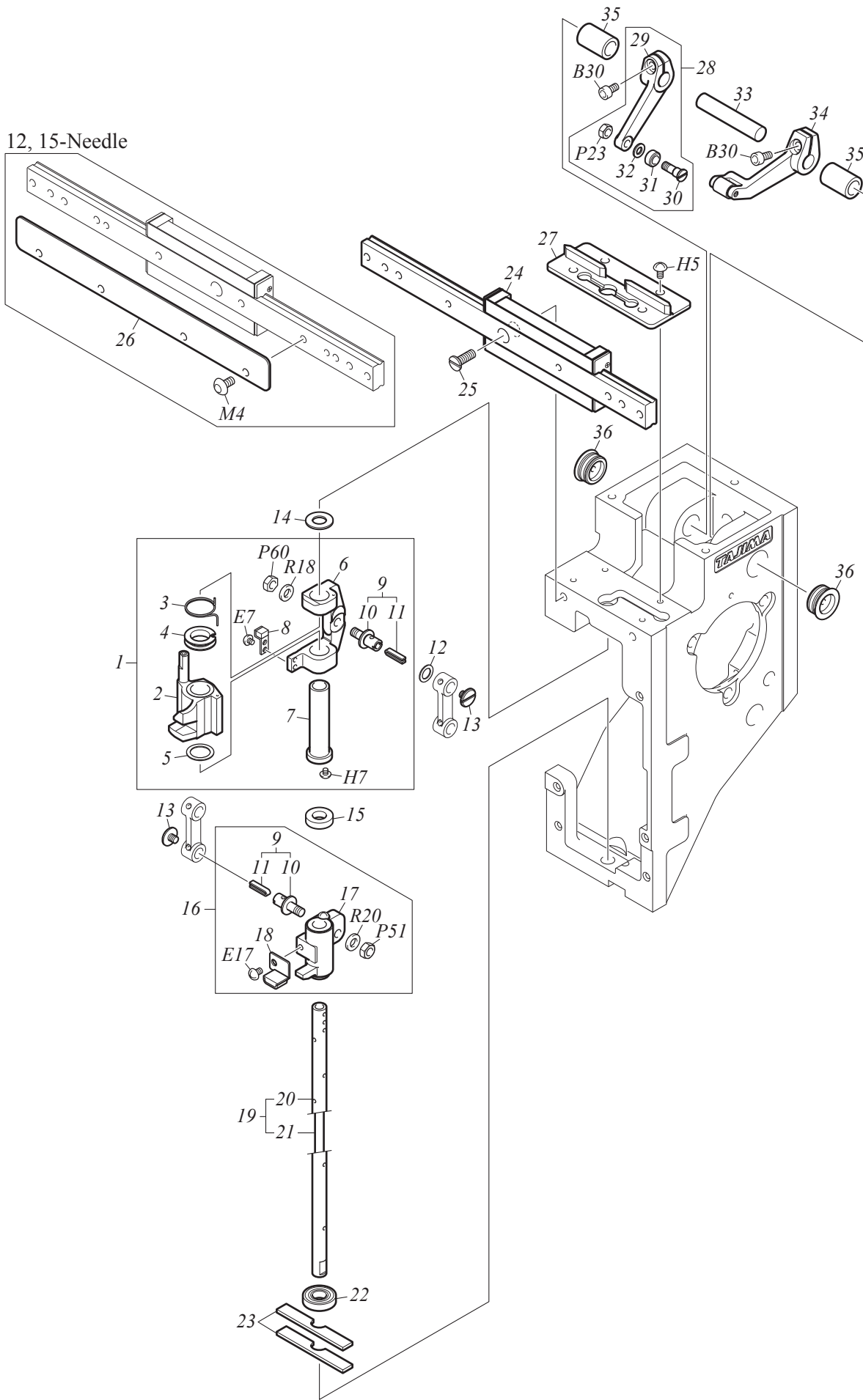

ARM 2

E2-5-2

No.	Part Name	Part No.	Remark
1	NEEDLE BAR RECIPROCATOR :GN[A]	080210360A80	
2	NEEDLE BAR RECIPROCATOR[S]	080210270S40	
3	TORSION SPRING :0.7MM DIA.	507307010010	
4	HOLDER :JUMP SPRING	080210110010	
5	PLAIN WASHER :10.3*14*T0.5	519112010000	
6	RECIPROCATING SLIDE BLOCK	080210410050	
7	PLASTIC BUSHING :NO.2 :7.24MM DIA.	509472050020	
8	DAMPER BRACKET :NEEDLE BAR RECIPROCATOR	080210090000	
9	SCREW WITH PIN :NO.3 :11/64-7.9[A]	513354060A20	
10	SCREW WITH PIN :NO.3 :11/64-7.9	513354060020	
11	WICK :2.5*1*22	080240120010	
12	PLAIN WASHER :6*9.5*T0.05-0.5	51910604@020	
13	FLAT FILLISTER HEAD SCREW :9/64*4	511153010010	
14	FELT :14MM DIA.	080240060000	t1
15	FELT :14MM DIA.	080240220000	t3
16	PRESSER FOOT RECIPROCATOR :47MM ST[A]	080210420A20	
17	PRESSER FOOT RECIPROCATOR :47MM ST[S]	080210420S10	
18	DAMPER BRACKET :PRESSER FOOT RECIPROCATOR[S]	080210180S20	
19	NEEDLE BAR DRIVE SHAFT :AUTOMATIC LUBRICATION[S]	0L0210030S10	
20	NEEDLE BAR DRIVE SHAFT :AUTOMATIC LUBRICATION	0L0210030000	
21	WICK :3.5P*158	080240020020	
22	GUIDE :NEEDLE BAR CASE[S]	080250170S20	
23	FELT :NEEDLE BAR DRIVE SHAFT :D	080240170000	
24	LINEAR WAY :NEEDLE BAR CASE	08025004@000	
25	COUNTERSUNK HEAD SCREW :11/64*40*13	511454010000	
26	REINFORCING PLATE	08025005@000	
27	TAKE-UP LEVER GUIDE	080280070010	
28	LEVER :TAKE-UP LEVER[S]	080230020S00	
29	LEVER :TAKE-UP LEVER	080230020000	
30	STEPPED SCREW :NO.1 :M4*12.2	512104180000	
31	ROLLER :4.7*7.94*4	515121050020	
32	PLAIN WASHER :4*7.5*T0.8	519104060000	
33	STRAIGHT PIN :NO.1 :8MM DIA.	503101130000	
34	ARM :TAKE-UP LEVER[S]	080230060S00	
35	BEARING BUSHING :NO.1 :8MM DIA.	509508080000	
36	LID :TAKE-UP LEVER SHAFT HOLDER :15.3MM DIA.	080290270000	
37			
38			
39			
40			
41			
42			
43			
44			
45			
46			
47			
48			
49			
50			

Note: As for parts with mark @, please follow our instructions on Table of Contents in your parts order.

(YK09)

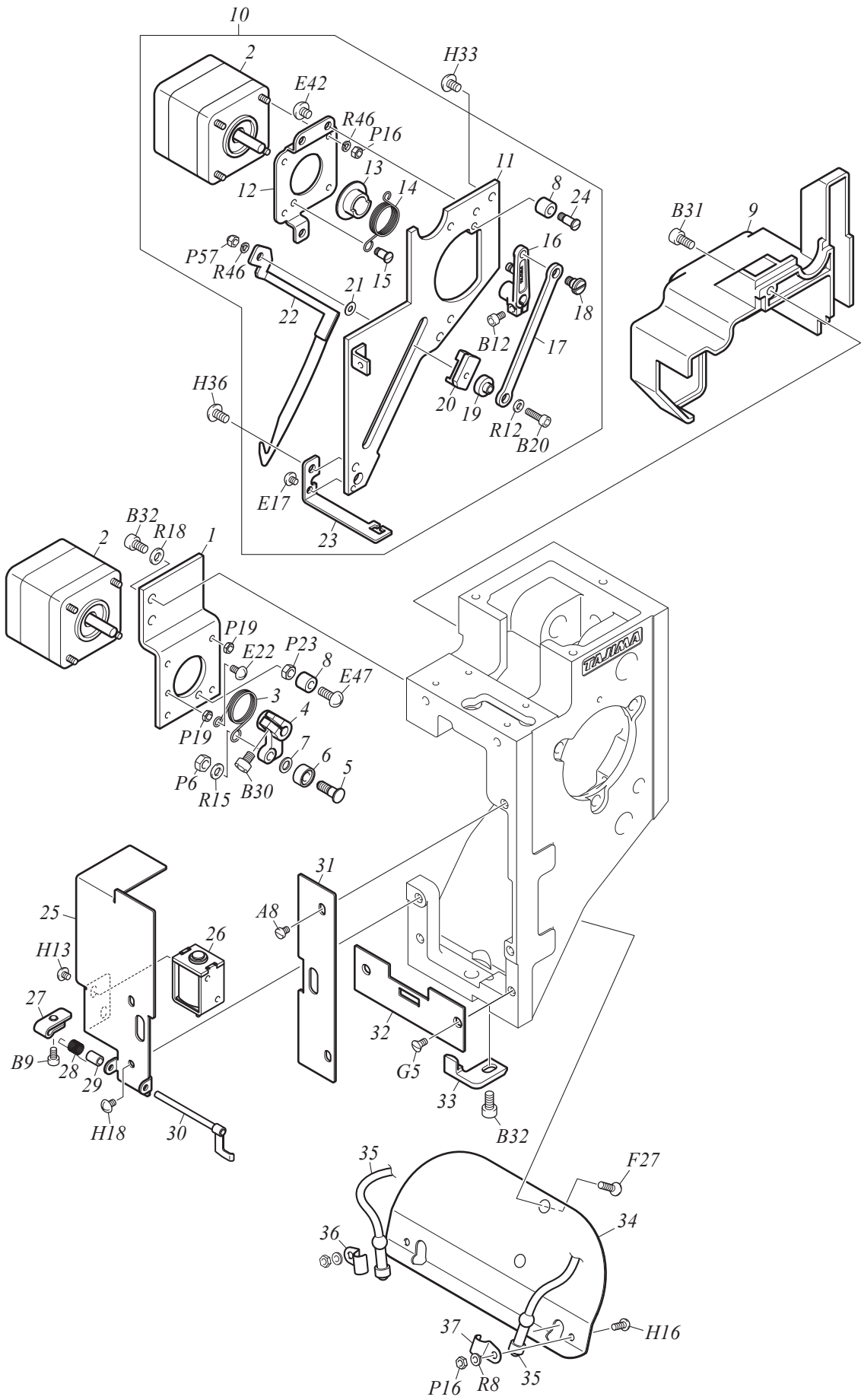

ARM 3

E2-5-3

No.	Part Name	Part No.	Remark
1	BRACKET :JUMP MOTOR	080320490000	
2	PULSE MOTOR :42MM SQUARE :DOUBLE-END[T]	0J6110700T10	
3	TORSION SPRING :0.9MM DIA.	507309040020	
4	LEVER :JUMP	080320420010	
5	STEPPED SCREW :NO.1 :11/64*14.7	512154010020	
6	ROLLER :4.7MM DIA.	515110010010	
7	WASHER :4.8*8*T0.8	S301040801KC	
8	DAMPER RING :4MM DIA.	080320410000	
9	HEAD COVER :L	080430290000	
10	UPPER THREAD HOLDER[A]	0B0110740A00	
11	SIDE COVER :HEAD :LOWER	080430220000	
12	BASE :HOOK MOTOR	0B0110420000	
13	COLLAR :SPRING GUIDE	502522010010	
14	TORSION SPRING :0.8MM DIA.	507308190010	
15	STEPPED SCREW :NO.1 :9/64*7.5	512153040000	
16	LEVER :HOOK	0B0110470000	
17	CONNECTING PLATE :HOOK	0B0110080010	
18	STEPPED SCREW :NO.1 :M4*6.7	512104100040	
19	SPACER :SLIDE HOOK	0B0110370010	
20	SLIDE :HOOK	0B0110510000	
21	WASHER :2.6*7*T0.5	519204010000	
22	HOOK[S]	0B0110650S10	
23	GUIDE :HOOK	0B0110520020	
24	STEPPED SCREW :NO.1 :9/64*10	512153020000	
25	HEAD FRONT COVER :L	08042002L020	
26	SOLENOID :OPEN FRAME	640600121001	
27	LEVER :SOLENOID	080270010010	
28	TORSION SPRING :0.5MM DIA.	507305020020	
29	COLLAR :NO.1 :3.1MM DIA.	502505010000	
30	LEVER :DRIVE[S]	080270040S20	
31	HEAD FRONT COVER :R	08042002R000	
32	GUIDE PLATE :NEEDLE BAR CASE	080250190020	
33	GUIDE BRACKET :NEEDLE BAR CASE	080250200000	
34	BRACKET :LED LAMP	0L2310020000	
35	LAMP :NEEDLE BASE LED LIGHT[A]	0J7101700A00	
36	CLAMP :LED LAMP :L	0L231003L000	
37	CLAMP :LED LAMP :R	0L231003R000	
38			
39			
40			
41			
42			
43			
44			
45			
46			
47			
48			
49			
50			

Note: As for parts with mark @, please follow our instructions on Table of Contents in your parts order.

(YK05)

NEEDLE BAR CASE 1

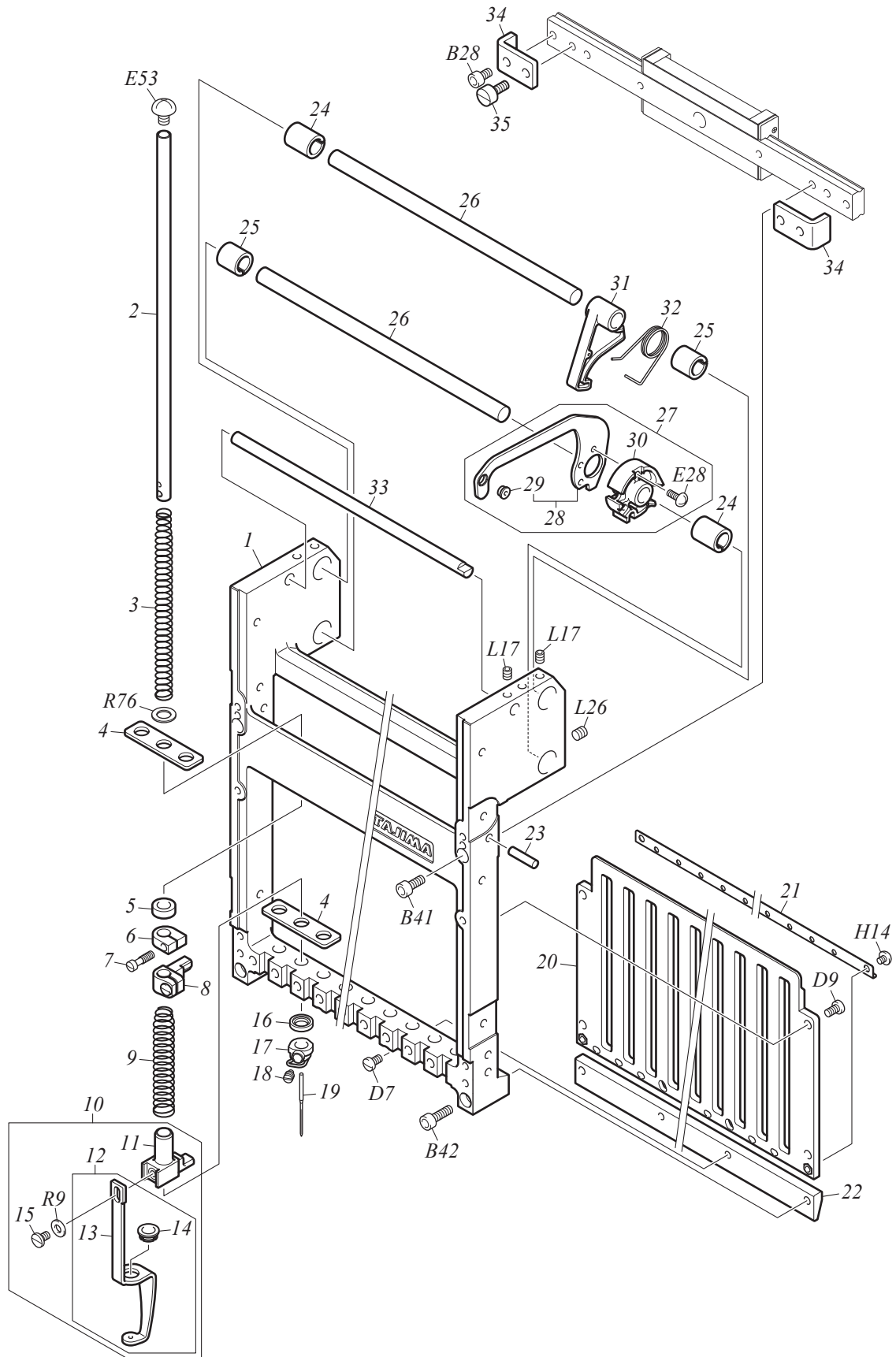

NEEDLE BAR CASE 1

E2-6-1

No.	Part Name	Part No.	Remark
1	NEEDLE BAR CASE	09012001@030	
2	NEEDLE BAR	090410020010	
3	COMPRESSION SPRING :0.5MM DIA.	507605030040	
4	FELT PACKING	090430040000	
5	DAMPER RING :F	090430020010	
6	STOPPER :UPPER DEAD POINT	090420090000	
7	FLAT FILLISTER HEAD SCREW :9/64*10.5	511153030000	
8	NEEDLE BAR CONNECTING STUD[A]	090420060A10	
9	COMPRESSION SPRING :0.9MM DIA.	507609060000	
10	PRESSER FOOT :A[A]	09046023AA00	2mm Dia.
10	PRESSER FOOT :A[A]	09046007AA00	3mm Dia. (Thick Thread)
11	PRESSER FOOT CONNECTING STUD	090420020020	
12	PRESSER FOOT[A]	090460230A00	2mm Dia.
12	PRESSER FOOT[A]	090460070A00	3mm Dia. (Thick Thread)
13	PRESSER FOOT	090460230000	2mm Dia.
13	PRESSER FOOT	090460070000	3mm Dia. (Thick Thread)
14	SPLIT COLLAR :PRESSER FOOT	090460040030	
15	FLAT FILLISTER HEAD SCREW :1/8*44	090470020010	
16	DAMPER RING :A	090430070040	
17	NEEDLE CLAMP[S]	090420010S70	
18	SLOTTED HEAD SET SCREW :11/64*6B	511754010010	
19	NEEDLE :DB-K5Z1 #11	616500080000	
20	NEEDLE BAR GUIDE	0904500@@010	
21	RAIL GUIDE	08027006@020	
22	RAIL :CASE :LOWER	09044005@000	
23	PARALLEL PIN :4*16-H7	611200050000	
24	SPLIT COLLAR :NO.1 :8MM DIA.	502308010010	
24	SPLIT COLLAR :NO.1 :8MM DIA.	502308020010	15-Needle
25	SPLIT COLLAR :NO.2 :8MM DIA.	502408020010	
25	SPLIT COLLAR :NO.2 :8MM DIA.	502408010020	15-Needle
26	GUIDE SHAFT :TAKE UP LEVER	09033001@000	
27	TAKE-UP LEVER[A]	09031005BA00	
28	TAKE-UP LEVER[S]	09031005BS00	
29	THREAD GUIDE COLLAR :2MM DIA.	51650302B000	
30	BOSS :TAKE-UP LEVER	090310040010	
31	LEVER :STOPPER	090320010000	
32	TORSION SPRING :1MM DIA.	507310040010	
33	SPRING HOOK BAR	09033002@000	
34	STOPPER :LINEAR WAY :26	080260220000	
35	FLAT FILLISTER HEAD SCREW :M4*10	511104010010	
36			
37			
38			
39			
40			
41			
42			
43			
44			
45			

Note: As for parts with mark @, please follow our instructions on Table of Contents in your parts order.

(ZJ06)

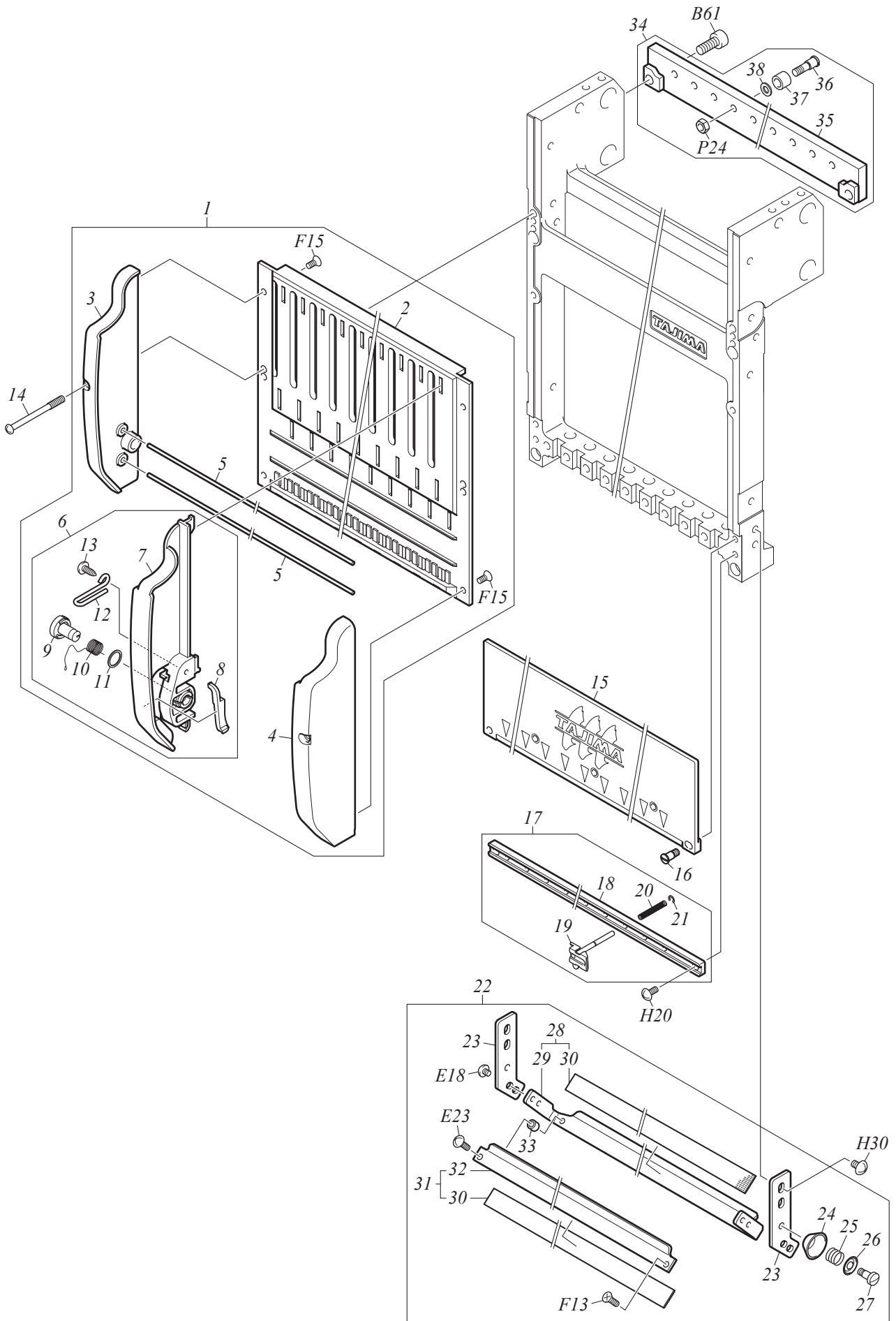

NEEDLE BAR CASE 2

E2-6-2

No.	Part Name	Part No.	Remark
1	TOP COVER[A]	09053023@A10	
2	TOP COVER	09053023@000	
3	SIDE COVER :L	09053019L000	
3	SIDE COVER :L :15-NEEDLE	09053020L000	
4	SIDE COVER :R	09053019R000	
4	SIDE COVER :R :15-NEEDLE	09053020R000	
5	STRAIGHT PIN :2MM DIA.	09021054@000	
6	BASE :MIDDLE THREAD GUIDE :0.4MM DIA.[A]	090210511A10	
6	BASE :MIDDLE THREAD GUIDE :0.5MM DIA.[A]	090210512A10	Thick Thread
7	BASE :MIDDLE THREAD GUIDE	090210510010	
8	SIDE WALL PLATE :MIDDLE THREAD GUIDE	090210500010	
9	SPRING SHAFT :THREAD TAKE-UP SPRING	090210520000	
10	THREAD TAKE-UP SPRING :NO.2 :0.4MM DIA.	507204030010	
10	THREAD TAKE-UP SPRING :NO.2 :0.5MM DIA.	507205030000	Thick Thread
11	PLAIN WASHER :8*10*T0.5	519108110000	
12	LARGE THREAD HOLDER	090210530000	
13	TRUSS HEAD TAPPING SCREW :3P*12	S530031201SD	
14	PAN HEAD SCREW :9/64*40	511353020000	
15	FACE COVER :NEEDLE BAR CASE	09051016@000	
16	STEPPED SCREW :NO.1 :9/64*8.8	512153150000	
17	UPPER THREAD LOCK[A]	08027005@A10	
18	BASE :UPPER THREAD LOCK	08027005@000	
19	LOCK SHAFT[S]	080270030S10	
20	COMPRESSION SPRING :0.3MM DIA.	507603040030	
21	E-RING :1.5MM DIA.	611100040000	
22	UPPER THREAD HOLDER :06-15-NEEDLE[A]	0B020033@A10	
23	BRACKET :UPPER THREAD HOLDER	0B0200010000	
24	THREAD SUSPENDER DISK	0B0200050000	
25	COMPRESSION SPRING :0.3MM DIA.	507603020010	
26	PRESSER :THREAD SUSPENDER SPRING	0B0200060000	
27	STEPPED SCREW :NO.1 :9/64*7.5	512153040000	
28	BASE :UPPER THREAD HOLDER :06-15-NEEDLE[S]	0B020034@S10	
29	BASE :UPPER THREAD HOLDER	0B020034@000	
30	HOOK AND LOOP FASTENERS :W12	0B020054@000	
31	UPPER THREAD HOLDER :06-15-NEEDLE[S]	0B020033@S10	
32	UPPER THREAD HOLDER	0B020033@000	
33	COLLAR :NO.1 :3MM DIA.	502503070010	
34	BASE :CHANGE ROLLER :06-15-NEEDLE[A]	0701105@@A00	
35	BASE :CHANGE ROLLER :06-15-NEEDLE[S]	0701105@@S00	
36	STEPPED SCREW :NO.1 :M4*5.3	512104160020	
37	ROLLER :5*8*5	515105020010	
38	PLAIN WASHER :4*7.5*T0.8	519104060000	
39			
40			
41			
42			
43			
44			
45			
46			

Note: As for parts with mark @, please follow our instructions on Table of Contents in your parts order.

(ZJ01)

X-AXIS DRIVE SYSTEM

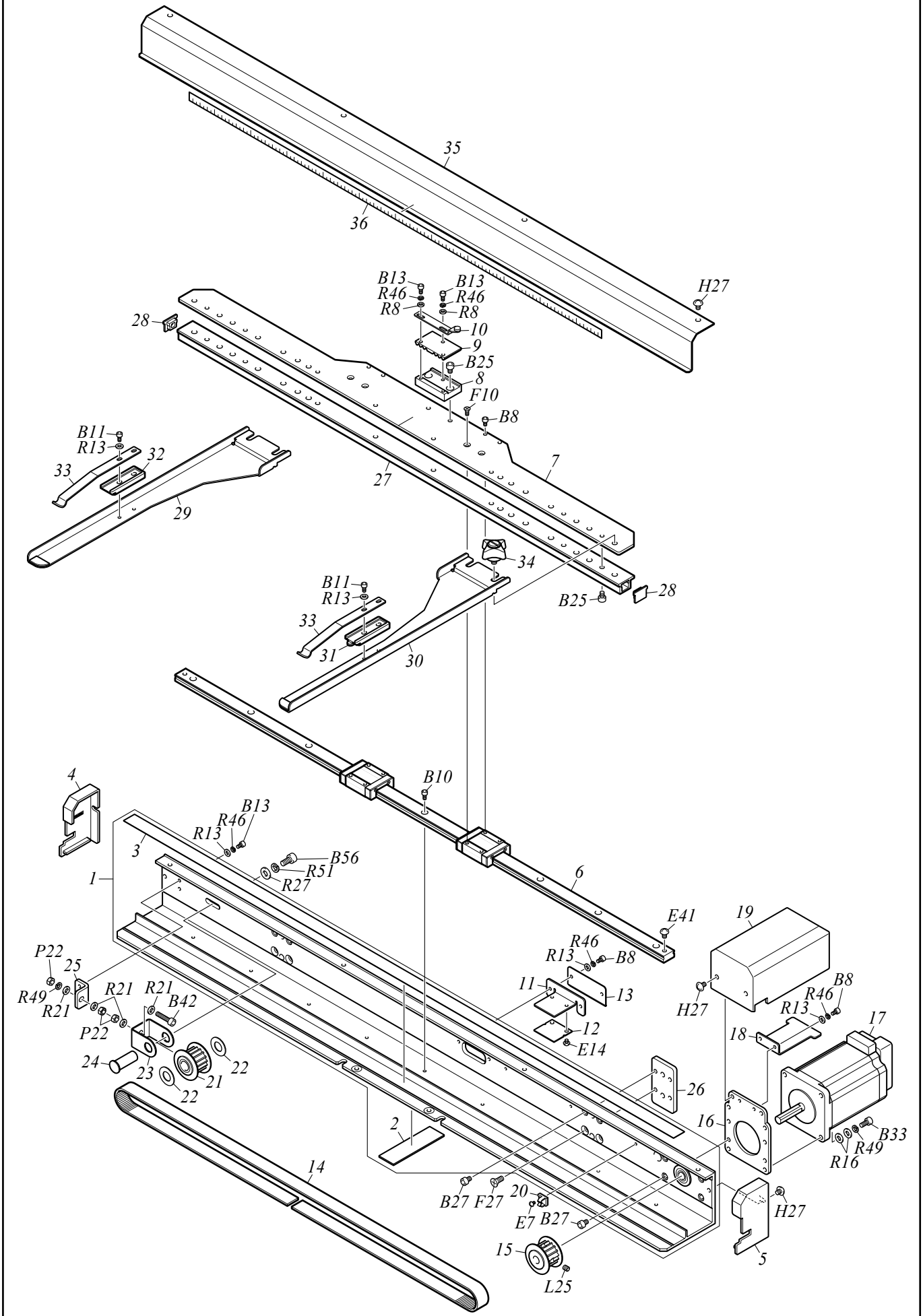

X-AXIS DRIVE SYSTEM

E2-7

No.	Part Name	Part No.	Remark
1	Z-SPEC. FRAME :0001/500S[S]	0F4110570S00	
2	FELT :T1.7[S]	0G0140120S00	
3	RESIN TAPE :W15*L760	520103800000	
4	SIDE COVER :Z-SPEC. FRAME SASH :L	0F416080L000	
5	SIDE COVER :Z-SPEC. FRAME SASH :R	0F416080R000	
6	LINEAR WAY :X DRIVE SYSTEM	660300110001	
7	JOINT :SLIDE BASE	0F4120270000	
8	BELT CATCHER :NO.1 :X	0F4160740000	
9	BELT CATCHER :NO.2 :X	0F4160750000	
10	SENSOR PLATE :NO.1[S]	0F4140110S00	
11	BRACKET :MAGNETIC SENSOR	0F4140120000	
12	CARD :MAGNETIC SENSOR A	0J4204400000	
13	COVER :SASH REAR	0F4160790000	
14	TIMING BELT :MA5 :W15-274E/LY	623A00090000	
15	TIMING PULLEY :W15-16	501430140020	
16	BRACKET :X MOTOR	0F4150420000	
17	PULSE MOTOR :60MM SQUARE :WITH SENSOR[A]	0J6105400A10	
18	HOLDER :HARNESS	0F4150430000	
19	COVER :X MOTOR	0F4150450000	
20	MINI CLAMP :MB-2	644100080000	
21	TIMING PULLEY :W15-16[S]	501430060S10	
22	PLASTIC WASHER :10.2*15*T0.5	519212030000	
23	HOLDER :TIMING PULLEY	0F4160720000	
24	FLANGE PIN :NO.3	503503050000	
25	TENSIONER :X DRIVE BELT	0F4160730000	
26	SPACER :Z-SPEC. FRAME SASH	0F4160760000	
27	SLIDE BASE :0001/500S	0F4110580000	
28	SIDE COVER :SLIDE BASE	0F4160780000	
29	FRAME HOLDER :L[S]	0G314022LS00	
30	FRAME HOLDER :R[S]	0G314022RS00	
31	STOPPER :NO.1	0G314001A020	
32	STOPPER :NO.2	0G314002B020	
33	PLATE SPRING :HOLDER BASE :T1.5	507815060010	
34	KNOBBED SCREW :NO.2 :M5*6[S]	511F05110S00	
35	COVER :Z-SPEC. FRAME :0001/500S	0F4110590000	
36	TRAVERSE SCALE	0P1200020000	
37			
38			
39			
40			
41			
42			
43			
44			
45			
46			
47			
48			
49			
50			

Note: As for parts with mark @, please follow our instructions on Table of Contents in your parts order.

(YK05)

Y-AXIS DRIVE SYSTEM

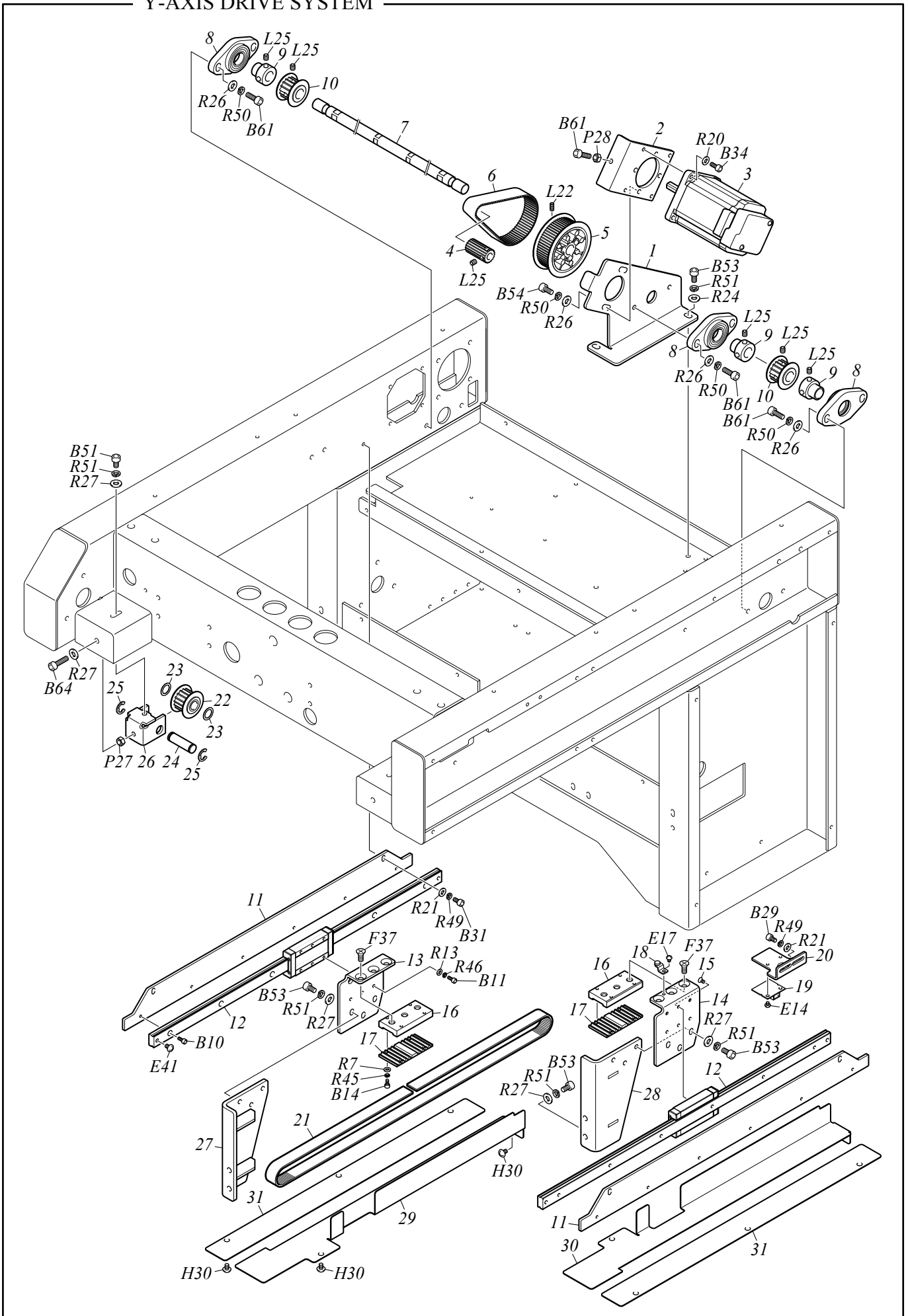

Y-AXIS DRIVE SYSTEM

E2-8

No.	Part Name	Part No.	Remark
1	BRACKET :Y MOTOR :B	0F424010B000	
2	BASE :Y MOTOR	0F4240010000	
3	PULSE MOTOR :60MM SQUARE :WITH SENSOR[A]	0J6105400A10	
4	TIMING PULLEY :W19-18	501F18020000	
5	TIMING PULLEY :W20-63	501F17010000	
6	TIMING BELT :3GT :19*270/E	628300010001	
7	Y SHAFT :B :12P*500	QE110301B000	
8	BEARING CASE :NO.3 :15MM DIA.[S]	508315040S00	
9	BEARING COLLAR :12MM DIA.	502712020000	
10	TIMING PULLEY :W15-16	501430020020	
11	BASE :LINEAR WAY	0F4230750000	
12	LINEAR WAY :L450	660400000001	
13	DRIVE ARM :Z-SPEC. FRAME :L	0F423081L000	
14	DRIVE ARM :Z-SPEC. FRAME :R	0F423081R000	
15	COUNTERSUNK HEAD SCREW :M3*6	511403010000	
16	BELT CATCHER :NO.1	0F4230630000	
17	BELT CATCHER :NO.2	0F4230640000	
18	SENSOR PLATE :NO.1 :B[S]	0F423067BS00	
19	CARD :MAGNETIC SENSOR A	0J4204400000	
20	BRACKET :ORIGIN SENSOR :B	0F423066B000	
21	TIMING BELT :MA5 :W15-230E/LY	623A00060000	
22	TIMING PULLEY :W15-16[S]	501430060S10	
23	PLASTIC WASHER :10.2*15*T0.5	519212030000	
24	STRAIGHT PIN :NO.4 :10MM DIA.	503104240000	
25	E-RING :7MM DIA.	611100100000	
26	HOLDER :TENSION PULLEY :B	0F421006B000	
27	BRACKET :DRIVE ARM :B :L	0F423077L000	
28	BRACKET :DRIVE ARM :B :R	0F423077R000	
29	COVER :Y DRIVE SYSTEM :L :LED	0F423079L000	
30	COVER :Y DRIVE SYSTEM :R :LED	0F423079R000	
31	COVER :Y DRIVE SYSTEM	0F4230800000	
32			
33			
34			
35			
36			
37			
38			
39			
40			
41			
42			
43			
44			
45			
46			
47			
48			
49			
50			

Note: As for parts with mark @, please follow our instructions on Table of Contents in your parts order.

(YK05)

TENSION BASE

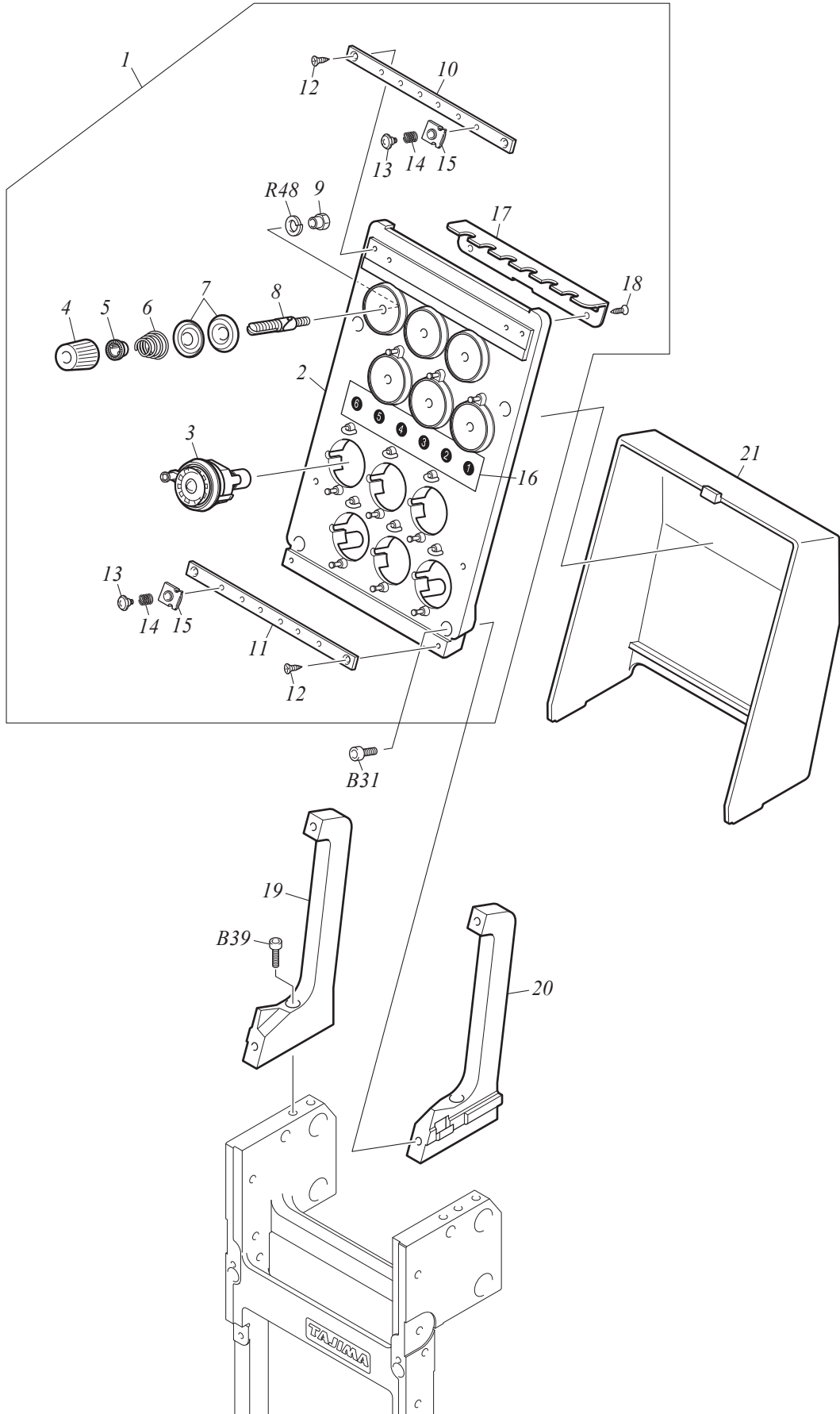

TENSION BASE

E2-9

No.	Part Name	Part No.	Remark
1	TENSION BASE :06-15-NEEDLE[A]	0C016003@A30	
2	TENSION BASE :ROTARY	0C012001@040	
3	ROTARY TENSION DISK[A]	0C0230320A10	
4	KNOB :THREAD TENSION :A	0C0220150000	
5	SPRING HOOK	0C0220080000	
6	TAPER SPRING :0.6MM DIA.	507706010000	
7	TENSION DISK	0C0210060000	
8	THREAD TENSION STUD :WITH GROOVE	0C0210040000	
9	SCREW BUSHING :NO.2 :M4	509804050000	
10	BASE :THREAD PRESSER :U :06-NEEDLE	0C0220316000	
10	BASE :THREAD PRESSER :U :12-NEEDLE	0C022035Y000	
10	BASE :THREAD PRESSER :U :15-NEEDLE	0C022037X000	
11	BASE :THREAD PRESSER :D :06-NEEDLE	0C0220326000	
11	BASE :THREAD PRESSER :D :12-NEEDLE	0C022036Y000	
11	BASE :THREAD PRESSER :D :15-NEEDLE	0C022038X000	
12	COUNTERSUNK TAPPING SCREW :3P*10	S550031001SD	
13	TRUSS HEAD SCREW :STEPPED :M3*4*2	S132030401TD	
14	COMPRESSION SPRING :0.2MM DIA.	507602010000	
15	THREAD PRESSER	0C0220400000	
16	LABEL :NEEDLE BAR NO.	0P140002@010	
17	UPPER THREAD GUIDE :TENSION BASE	0C022017@020	
18	COUNTERSUNK TAPPING SCREW :3P*8	S550030801SD	
19	BRACKET :TENSION BASE :L[S]	0C024003LS00	
20	BRACKET :TENSION BASE :R[S]	0C024003RS00	
21	COVER :TENSION BASE	0C015006@000	
22			
23			
24			
25			
26			
27			
28			
29			
30			
31			
32			
33			
34			
35			
36			
37			
38			
39			
40			
41			
42			
43			
44			
45			
46			

Note: As for parts with mark @, please follow our instructions on Table of Contents in your parts order.

(YK10)

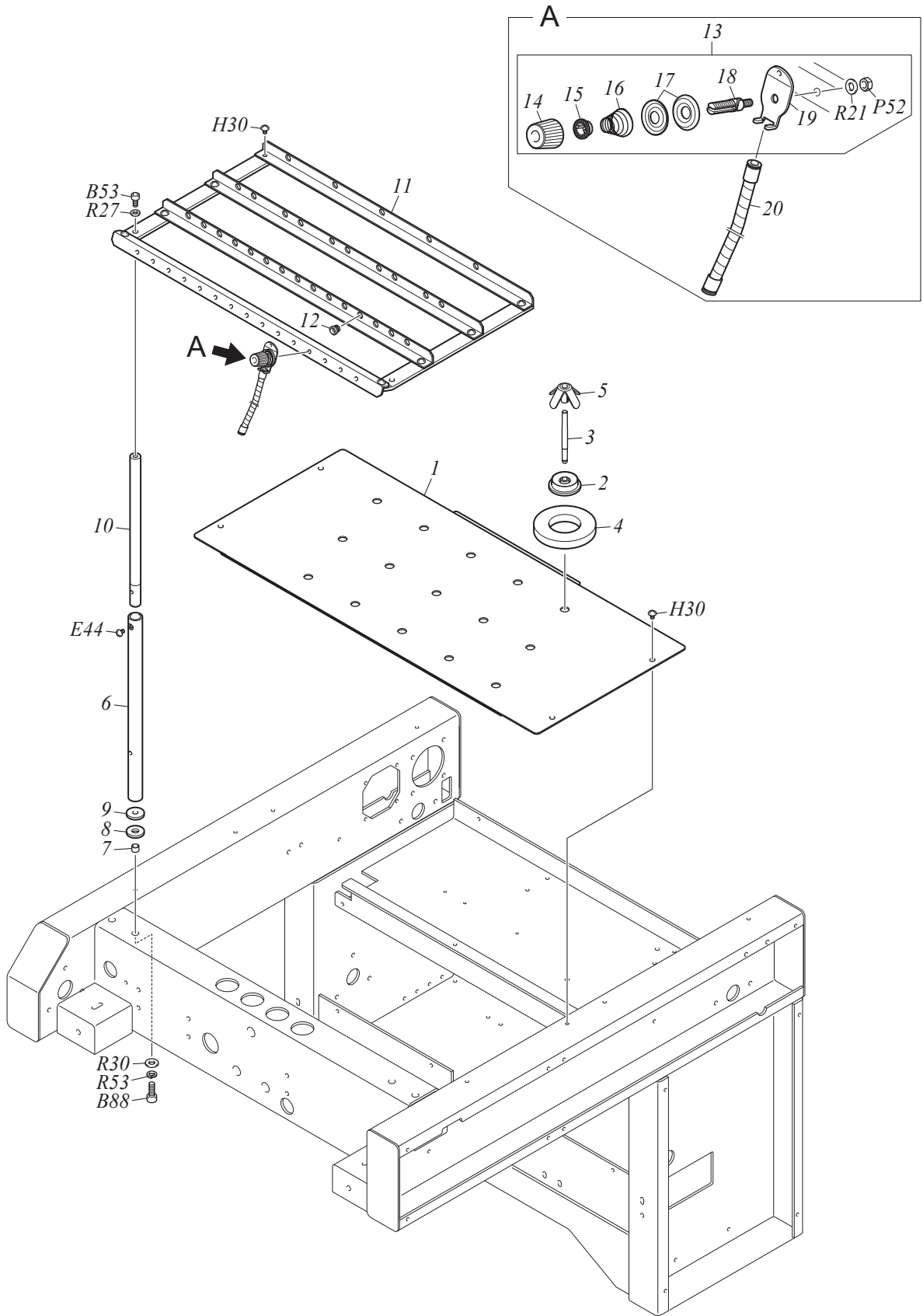

THREAD STAND

E2-10

No.	Part Name	Part No.	Remark
1	THREAD STAND PLATE[S]	1DL1010@@S10	
2	BASE :THREAD STAND STUD	0D0110420000	
3	THREAD STAND STUD	0D0110410000	
4	THREAD STAND RING :T10	0D0110022010	
5	THREAD STAND BLADE	0D0110010010	
6	THREAD COURSE SUPPORT BAR :A	0D0210490000	
7	COLLAR :NO.1 :6MM DIA.	502506060000	
8	RUBBER WASHER :8*20*t3	519208050000	
9	PLAIN WASHER :6*20*t3	519106170000	
10	THREAD COURSE SUPPORT BAR :B	0D0210470010	
11	THREAD COURSE	1ED10101@020	
12	THREAD GUIDE COLLAR :BLACK :4.5MM DIA.	516501012010	
12	THREAD GUIDE COLLAR :RED :4.5MM DIA.	516501011010	
13	THREAD TENSION :TUBE :B	UD1100000200	
14	KNOB :THREAD TENSION :A	0C0220150000	
15	SPRING HOOK	0C0220080000	
16	TAPER SPRING :0.6MM DIA.	507706010000	
17	TENSION DISK	0C0220160010	
18	THREAD TENSION STUD :WITH GROOVE	0C0210040000	
19	THREAD TENSION GUIDE :TUBE	0D0210150030	
20	SPIRAL TUBE :L230[A]	0D0210052A00	
21			
22			
23			
24			
25			
26			
27			
28			
29			
30			
31			
32			
33			
34			
35			
36			
37			
38			
39			
40			
41			
42			
43			
44			
45			
46			
47			
48			
49			

Note: As for parts with mark @, please follow our instructions on Table of Contents in your parts order.

(YK05)

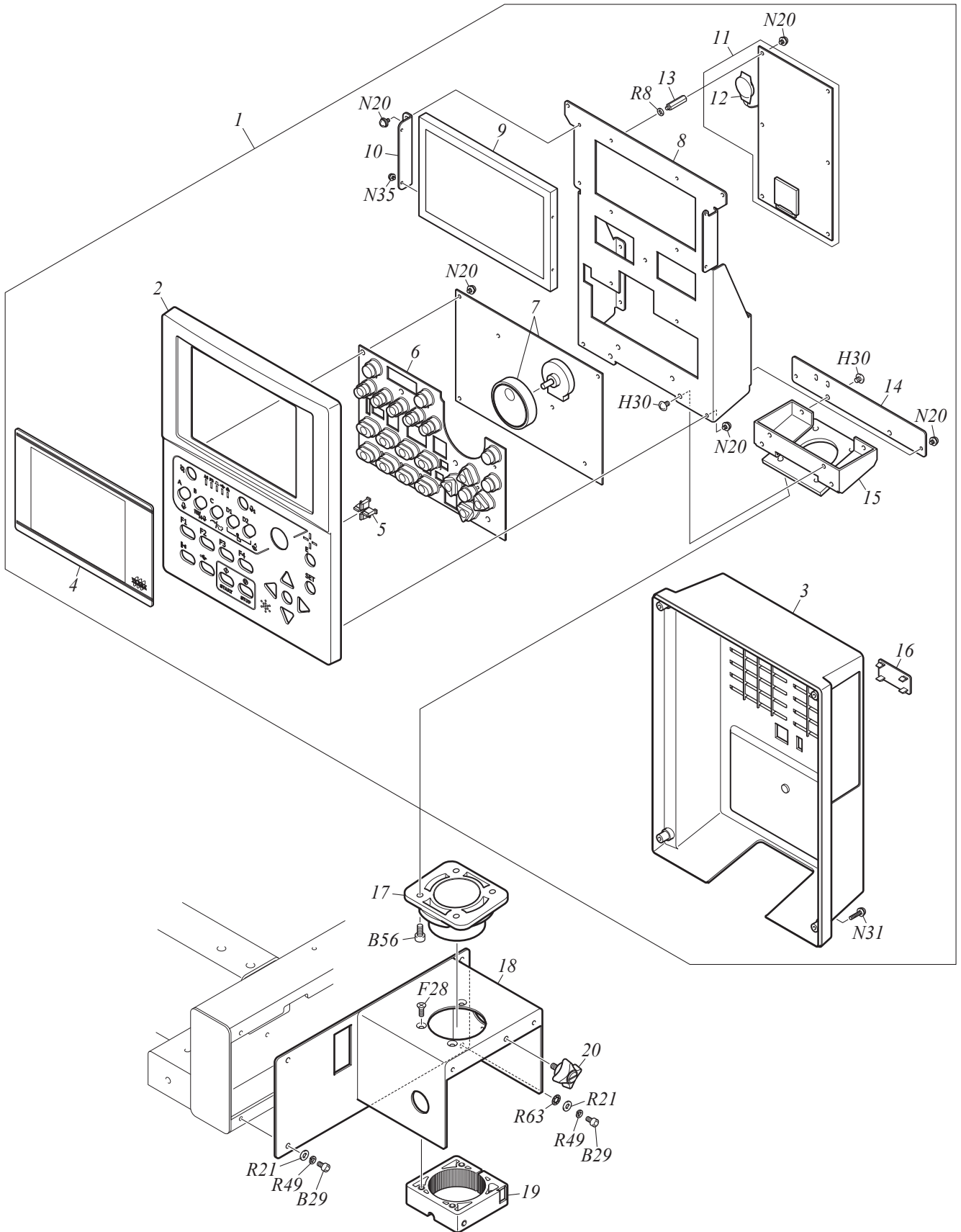

OPERATION PANEL

E2-11

No.	Part Name	Part No.	Remark
1	CONTROLLER :XC1[A]	0J0204700A30	
2	OPERATION PANEL :FRONT[S]	0J1414800S20	
3	OPERATION PANEL :REAR[S]	0J1411700S00	
4	COVER :LCD PANEL	0J1414900000	
5	COVER :LAMP	0J1404700000	
6	OPERATION BUTTON	0J1404500000	
7	CARD :SWITCH :XC1	0J3504400000	
8	BASE :PANEL CARD	0J1415000000	
9	LCD :7 INCH WIDE	641200250000	
10	BRACKET :LCD	0J1415100000	
11	CARD :CPU :XC1[A]	0J2306300A20	
12	LITHIUM BATTERY :XC[A]	645300490A01	
13	SPACER :HEXAGON :L20 :M3 :UNDER HEAD 3MM	644501750000	
14	SUPPORT :PANEL BASE	0J1406600020	
15	BASE :OPERATION PANEL[S]	0J1405000S00	
16	BLIND LID :USB	0J1409200000	
17	HOLDER :OPERATION PANEL	030221040000	
18	BASE :OPERATION PANEL	9A031230@000	
19	CLAMP :CONTROLLER HOLDER[S]	030220870S00	
20	KNOBBED SCREW :NO.2 :M5*9[S]	511F05120S00	
21			
22			
23			
24			
25			
26			
27			
28			
29			
30			
31			
32			
33			
34			
35			
36			
37			
38			
39			
40			
41			
42			
43			
44			
45			
46			
47			
48			
49			
50			

Note: As for parts with mark @, please follow our instructions on Table of Contents in your parts order.

(ZJ02)

ELECTRICAL PARTS

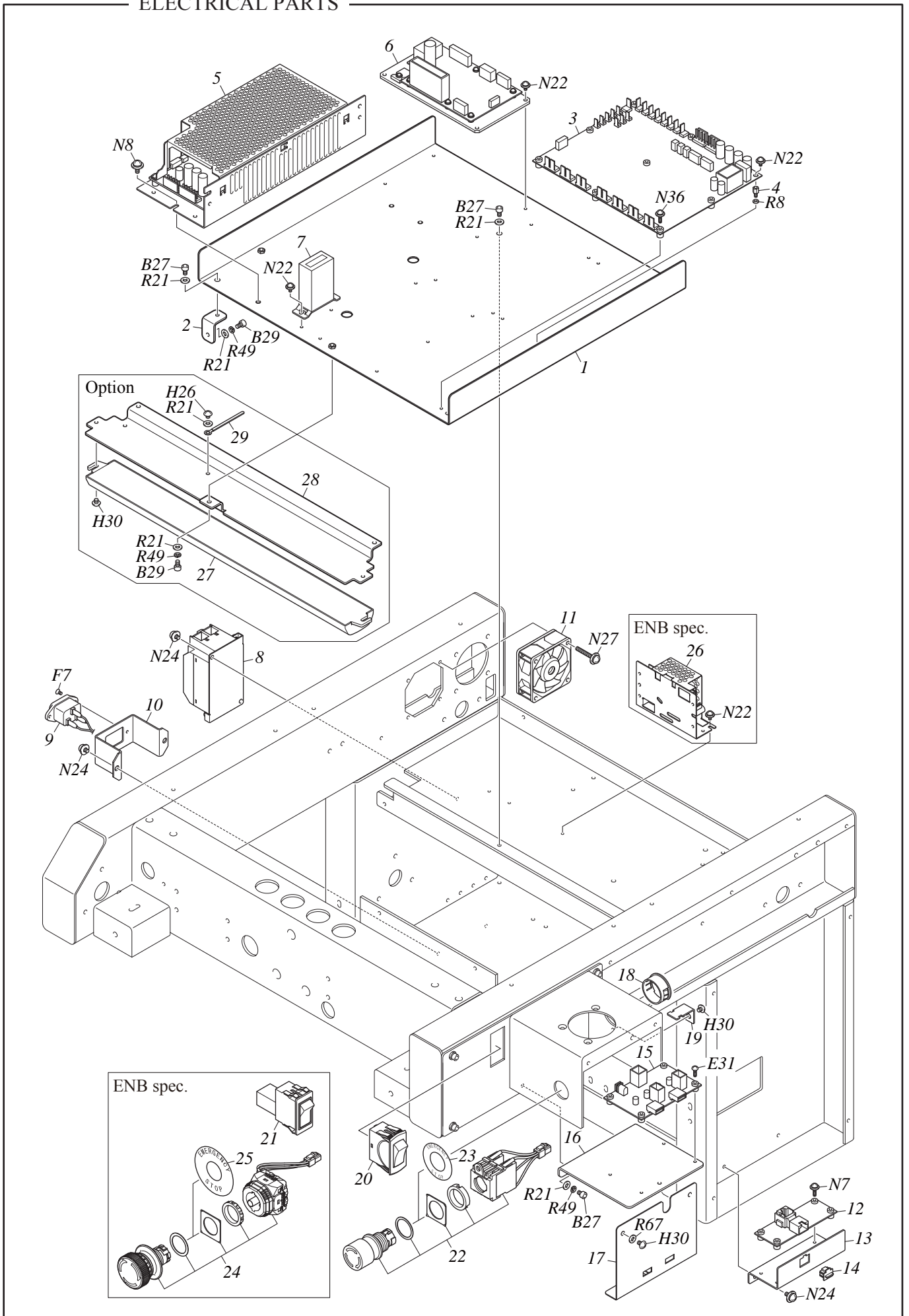

ELECTRICAL PARTS

E2-12

No.	Part Name	Part No.	Remark
1	BASE :ELECTRICAL COMPONENT	030190690000	
2	BRACKET :ELECTRICAL COMPONENT BASE	030110370000	
3	CARD :CONTROL	0J2206900000	
4	SPACER :HEXAGON :L6 :M3	644500890000	
5	DC POWER SUPPLY :24V :350W	645300500000	
6	MAIN SHAFT DRIVER :X14 :200[A]	0J0305000A10	
7	COUNTER :ELECTRO-MAGNETIC	0J4500200010	
8	NOISE FILTER :SINGLE-PHASE :10A	641400250000	
9	AC INLET	643500260000	
10	BASE INLET	030190600000	
11	MOTOR :FAN :60MM SQUARE	0J6500700000	
12	CARD :CONNECTOR :A	0J2503800000	
13	BRACKET :CONNECTOR CARD	030190670000	
14	DUST CAP :LAN	644501460000	
15	CARD :USB HUB :B	0J2503701000	
16	BRACKET :USB CARD	03022109@000	
17	COVER :BASE	03022110@000	
18	BUSHING :HARNESS	0J1501100020	
19	STAY :WIRING	0F4160360010	
20	CIRCUIT PROTECTOR :SINGLE-PHASE 10A	646100310010	
21	CIRCUIT PROTECTOR :SINGLE-PHASE 10A[A]	646100310A10	
22	SWITCH :EMERGENCY STOP	0J0607500A00	
23	NAME PLATE :EMERGENCY STOP SWITCH	0J5108800000	
24	SWITCH :EMERGENCY STOP :CE	642300670000	
25	NAME PLATE :EMERGENCY STOP SWITCH	0J5100600000	
26	DC POWER SUPPLY :5V :10W	645300560000	
27	LAMP :LED LIGHT :16W	0J7101800000	
28	BRACKET :LED LIGHT	0L2310050000	
29	COATED CLIP :5	644500150000	
30			
31			
32			
33			
34			
35			
36			
37			
38			
39			
40			
41			
42			
43			
44			
45			
46			
47			
48			
49			
50			

Note: As for parts with mark @, please follow our instructions on Table of Contents in your parts order.

(ZJ07)

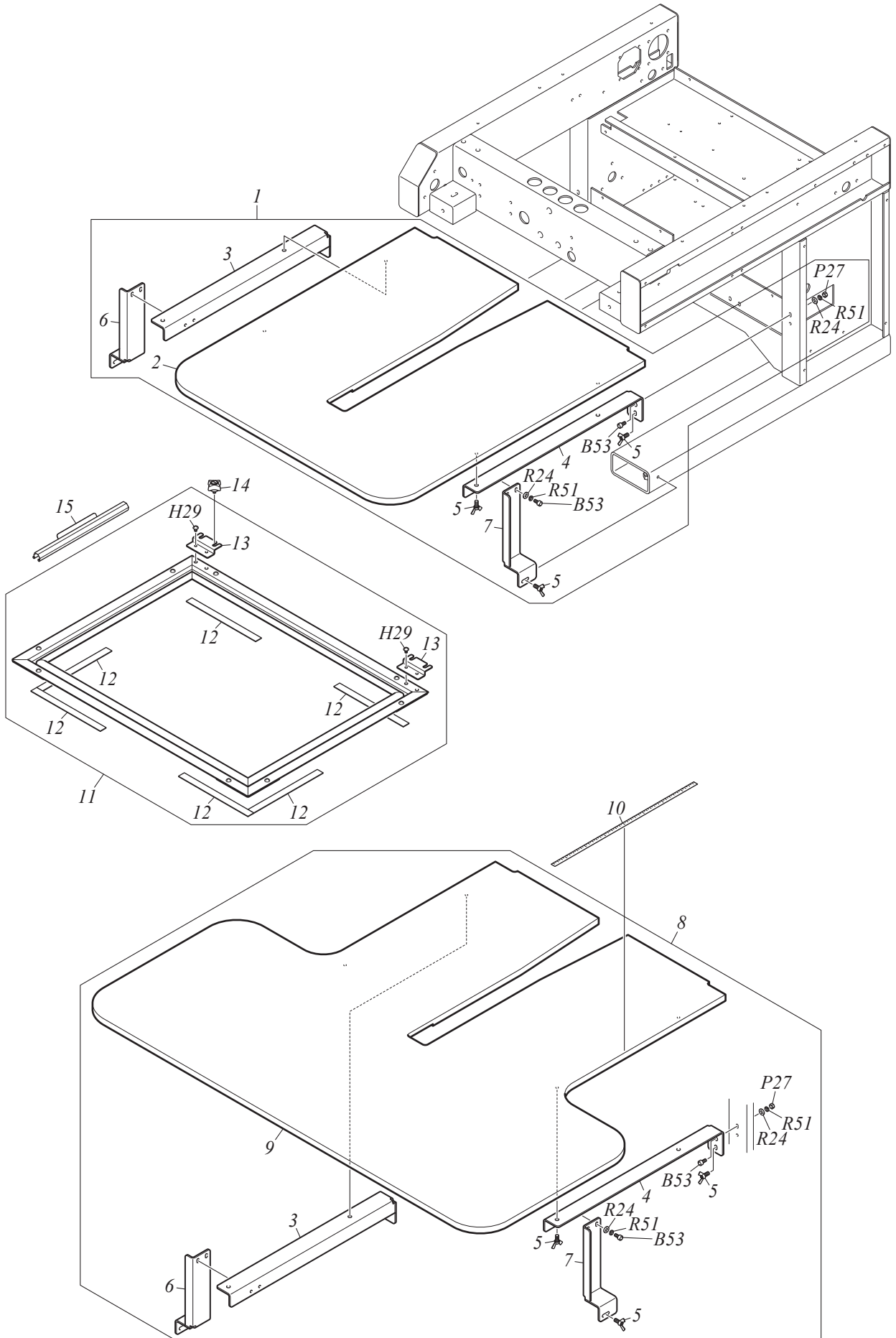

TABLE, BORDER FRAME (OPTION)

E2-13

No.	Part Name	Part No.	Remark
1	TABLE :TUBULAR GOODS FRAME[T]	0L3120202T00	
2	TABLE	0L3120140010	Tubular Goods Frame
3	BASE :TABLE SUPPORT :L	0L312011L010	
4	BASE :TABLE SUPPORT :R	0L312011R010	
5	WING BOLT :TYPE 2 :M5*10	S180051001SD	
6	SUPPORT :TABLE :L	0L312012L020	
7	SUPPORT :TABLE :R	0L312012R020	
8	TABLE :BORDER FRAME[T]	0L3120200T00	
9	TABLE :BORDER FRAME	0L3120090020	
10	TRAVERSE SCALE	0P1200020000	
11	BORDER FRAME :0001/036*500S[A]	303150060A10	
12	FELT :15*2*180[S]	0G0240310S00	
13	BRACKET :BORDER FRAME	0G0280310000	
14	KNOBBED SCREW :NO.2 :M5*6[S]	511F05110S00	
15	BORDER FRAME CLIP :BFF8 :L100-300[S]	0G052021@S00	
16			
17			
18			
19			
20			
21			
22			
23			
24			
25			
26			
27			
28			
29			
30			
31			
32			
33			
34			
35			
36			
37			
38			
39			
40			
41			
42			
43			
44			
45			
46			
47			
48			
49			
50			

Note: As for parts with mark @, please follow our instructions on Table of Contents in your parts order.

(YK05)

SIGNAL TOWER, STAND (OPTION)

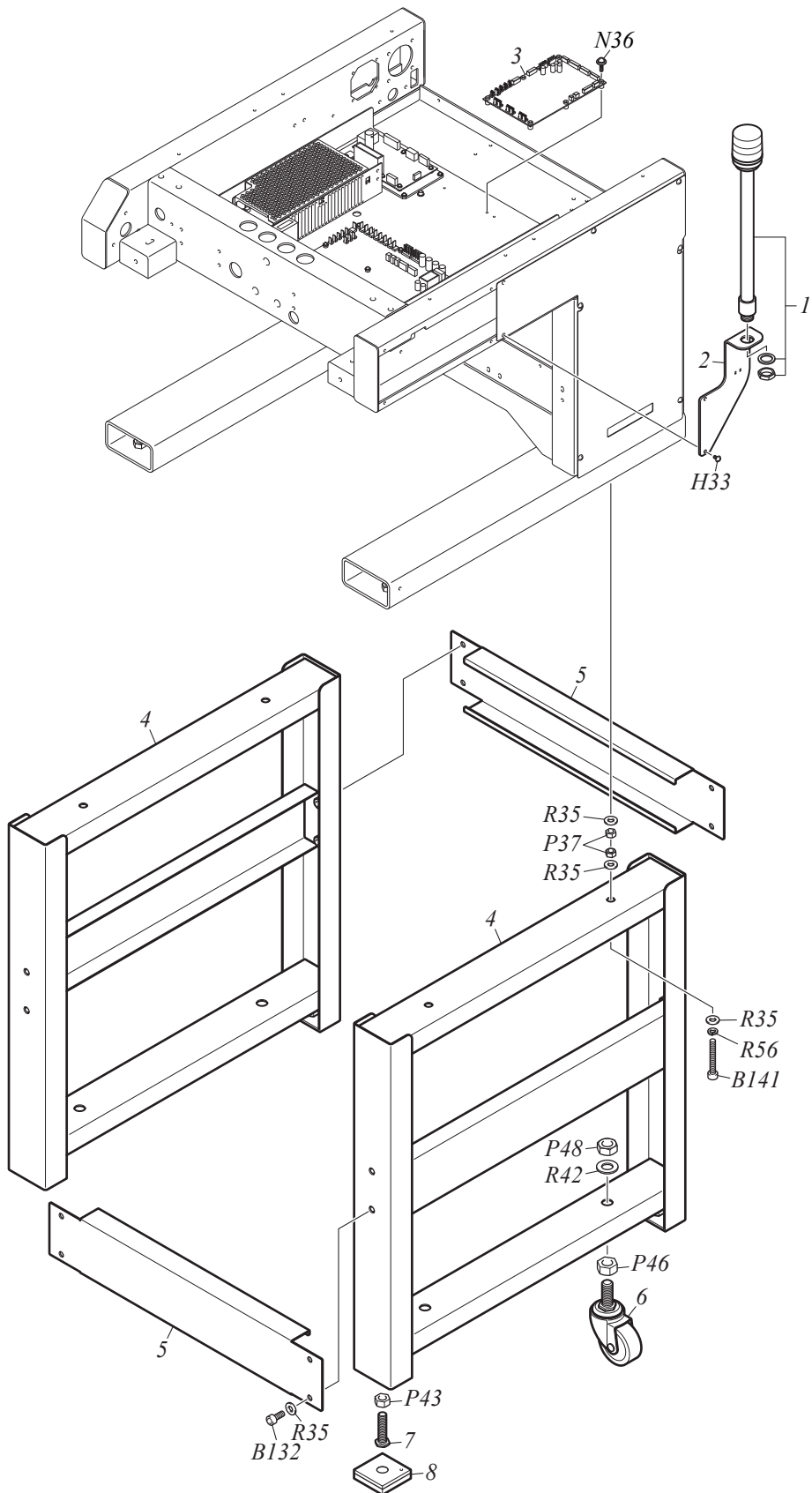

SIGNAL TOWER, STAND (OPTION)

E2-14

No.	Part Name	Part No.	Remark
1	LAMP :SIGNAL TOWER :LED ROTATING LIGHT	0J7102000000	
2	BRACKET :SIGNAL TOWER	0L3190140000	
3	CARD :OPTION	0J2207300000	
4	STAND STAND	0L311021@000	
5	JOINT :STAND	0L311022@000	
6	CASTER :ST-65RH M16*40	614300210000	
7	LEVELING BOLT :M12*50	030530040000	
8	VIBRATION-PREVENTIVE BASE[S]	03052004@S00	
9			
10			
11			
12			
13			
14			
15			
16			
17			
18			
19			
20			
21			
22			
23			
24			
25			
26			
27			
28			
29			
30			
31			
32			
33			
34			
35			
36			
37			
38			
39			
40			
41			
42			
43			
44			
45			
46			
47			
48			
49			
50			

Note: As for parts with mark @, please follow our instructions on Table of Contents in your parts order.

(YK05)

X-EXTENSION UNIT 1 (OPTION)

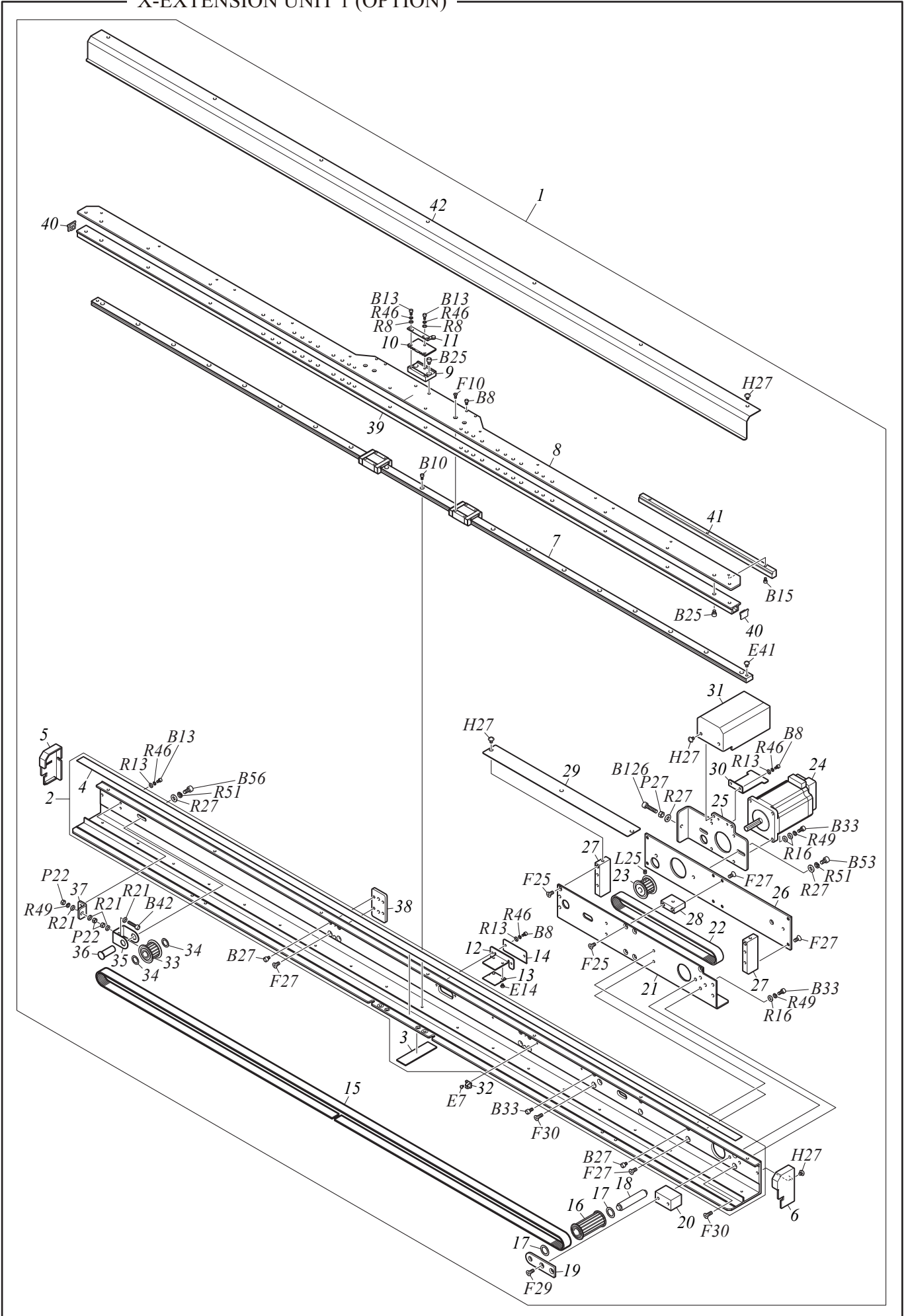

X-EXTENSION UNIT 1 (OPTION)

E2-15-1

No.	Part Name	Part No.	Remark
1	X-AXIS DRIVE SYSTEM :1200P[A]	0F4110640A00	
2	Z-SPEC. FRAME :0001/1200S[S]	0F4110610S00	
3	FELT :T1.7[S]	0G0140120S00	
4	RESIN TAPE :W15*L1484	520103810000	
5	SIDE COVER :Z-SPEC. FRAME SASH :L	0F416085L000	
6	SIDE COVER :Z-SPEC. FRAME SASH :R	0F416085R000	
7	LINEAR WAY :LWL-15C3R1470	660300100000	
8	JOINT :SLIDE BASE :0001/1200S	0F4120280000	
9	BELT CATCHER :NO.1 :X	0F4160740000	
10	BELT CATCHER :NO.2 :X	0F4160750000	
11	SENSOR PLATE :NO.1[S]	0F4140110S00	
12	BRACKET :MAGNETIC SENSOR	0F4140120000	
13	CARD :MAGNETIC SENSOR A	0J4204400000	
14	COVER :SASH REAR	0F4160790000	
15	TIMING BELT :MA5 :W15-534E/LY	623A00100000	
16	TIMING PULLEY :W15*2-16[S]	5014A0010S00	
17	PLASTIC WASHER :12.2*18*T0.5	519214010000	
18	STEPPED PIN :NO.1	503201230000	
19	SHAFT HOLDER PLATE	0F4160830000	
20	BASE :SHAFT HOLDER PLATE	0F4160820000	
21	BRACKET :X MOTOR	0F4150380000	
22	TIMING BELT :SPTG :W15-S5M0520/G	623200510000	
23	TIMING PULLEY :W15-16	501430140020	
24	PULSE MOTOR :60MM SQUARE :WITH SENSOR[A]	0J6105400A10	
25	BASE :X MOTOR	0F4150460000	
26	PLATE :X MOTOR	0F4150370000	
27	JOINT :PLATE :SIDE	0F4150390000	
28	JOINT :PLATE :CENTER	0F4150400000	
29	COVER :BELT	0F4150410000	
30	HOLDER :HARNESS	0F4150430000	
31	COVER :X MOTOR	0F4150470000	
32	MINI CLAMP :MB-2	644100080000	
33	TIMING PULLEY :W15-16[S]	501430060S10	
34	PLASTIC WASHER :10.2*15*T0.5	519212030000	
35	HOLDER :TIMING PULLEY	0F4160720000	
36	FLANGE PIN :NO.3	503503050000	
37	TENSIONER :X DRIVE BELT	0F4160730000	
38	SPACER :Z-SPEC. FRAME SASH	0F4160760000	
39	SLIDE BASE :0001/1200S	0F4110620000	
40	SIDE COVER :SLIDE BASE	0F4160780000	
41	VIBRATION-PREVENTIVE BLOCK :SLIDE BASE	0F4160840000	
42	COVER :Z-SPEC. FRAME :0001/1200S	0F4110630000	
43			
44			
45			
46			
47			
48			
49			
50			

Note: As for parts with mark @, please follow our instructions on Table of Contents in your parts order.

(YK05)

X-EXTENSION UNIT 2 (OPTION)

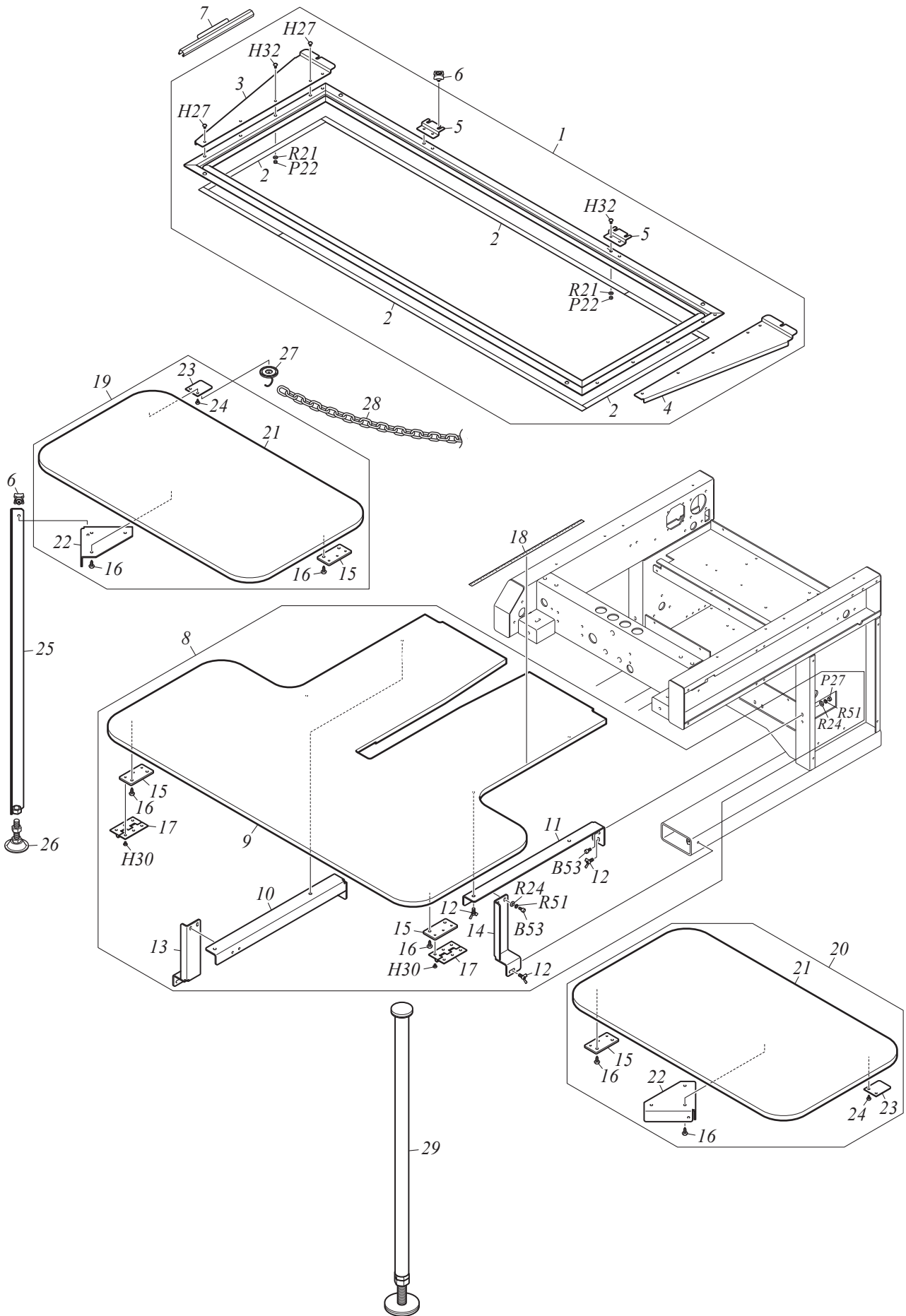

X-EXTENSION UNIT 2 (OPTION)

E2-15-2

No.	Part Name	Part No.	Remark
1	BORDER FRAME :0001/036*1200S[A]	303103040A10	
2	FELT :15*2*1000[S]	0G0240300S00	
3	SUPPORT :BORDER FRAME :L	0G028034L000	
4	SUPPORT :BORDER FRAME :R	0G028034R000	
5	BRACKET :BORDER FRAME	0G0280310000	
6	KNOBBED SCREW :NO.2 :M5*6[S]	511F05110S00	
7	BORDER FRAME CLIP :BFF8 :L100-300[S]	0G052021@S00	
8	TABLE :X-EXTENSION UNIT[T]	0L3120201T00	
9	TABLE :BORDER FRAME	0L3120090020	
10	BASE :TABLE SUPPORT :L	0L312011L010	
11	BASE :TABLE SUPPORT :R	0L312011R010	
12	WING BOLT :TYPE 2 :M5*10	S180051001SD	
13	SUPPORT :TABLE :L	0L312012L020	
14	SUPPORT :TABLE :R	0L312012R020	
15	BRACKET :HINGE	0L3120150000	
16	TRUSS HEAD TAPPING SCREW :5P*16	S530051601SD	
17	HINGE :FLAT TYPE	615300020000	
18	TRAVERSE SCALE	0P1200020000	
19	TABLE :X-EXTENSION UNIT :L[A]	0L312019LA00	
20	TABLE :X-EXTENSION UNIT :R[A]	0L312019RA00	
21	TABLE :X-EXTENSION UNIT	0L3120190000	
22	BRACKET :TABLE SUPPORT	0L3120160000	
23	TABLE HOLDER	030610010010	
24	TRUSS HEAD TAPPING SCREW :4P*10	S530041001SD	
25	TABLE SUPPORT :X-EXTENSION UNIT	0L312013C300	
26	ADJUSTER :55MM DIA.	614300280000	
27	MAGNET HANGER :CR-MG101	615800120000	
28	PC CHAIN :YELLOW/BLACK :6MM DIA.	613300110000	
29	TABLE SUPPORT[A]	030540150A10	
30			
31			
32			
33			
34			
35			
36			
37			
38			
39			
40			
41			
42			
43			
44			
45			
46			
47			
48			
49			
50			

Note: As for parts with mark @, please follow our instructions on Table of Contents in your parts order.

(YK05)

A, B

No.	Part No.	Remark	No.	Part No.	Remark
A Flat Fillister Head Screw			B17	S120031502TD	M3*15
A1	SA41730351CN	1/8*44*3.5	B18	S120031501TN	M3*15
A2	SA41730501CN	1/8*44*5	B19	S120031601TN	M3*16
A3	SA41730551CN	1/8*44*5.5	B20	S120031801TN	M3*18
A4	SA41730601CN	1/8*44*6	B21	S120032003TD	M3*20
A5	SA41740301CN	9/64*40*3	B22	S120032001TN	M3*20
A6	SA41740402CN	9/64*40*4	B23	S120032501TN	M3*25
A7	SA41740401SA	9/64*40*4	B24	S120033001TN	M3*30 Half Threads
A8	SA41740403CL	9/64*40*4	B25	S120040501TD	M4*5
A9	SA41740404CN	9/64*40*4	B26	S120040502TN	M4*5
A10	SA41740501CN	9/64*40*5	B27	S120040602TD	M4*6
A11	SA41740601CN	9/64*40*6	B28	S120040601TN	M4*6
A12	SA41740602CN	9/64*40*6	B29	S120040801TD	M4*8
A13	SA41740701CN	9/64*40*7	B30	S120040802TN	M4*8
A14	SA41740801CN	9/64*40*8	B31	S120041001TD	M4*10
A15	SA41740802CN	9/64*40*8	B32	S120041002TN	M4*10
A16	SA41740803CN	9/64*40*8	B33	S120041201TD	M4*12
A17	SA41741001CN	9/64*40*10	B34	S120041202TN	M4*12
A18	SA41741202CN	9/64*40*12	B35	S120041401TN	M4*14
A19	SA41741501CN	9/64*40*15	B36	S120041502TD	M4*15
A20	SA41750431TN	11/64*40*4.3	B37	S120041501TN	M4*15
A21	SA41750701CN	11/64*40*7	B38	S120041601TN	M4*16
A22	SA41750751CN	11/64*40*7.5	B39	S120041801TN	M4*18
A23	SA41750901SH	11/64*40*9	B40	S120042002TD	M4*20
A24	SA41751151CN	11/64*40*11.5	B41	S120042001TN	M4*20
A25	SA41751201CN	11/64*40*12	B42	S120042502TD	M4*25
A26	S141030801SC	M3*8	B43	S120042501TN	M4*25
A27	S141030802SD	M3*8	B44	S120042504TN	M4*25 Half Threads
A28	S141031001CC	M3*10	B45	S120043001TN	M4*30
A29	S141041001SC	M4*10	B46	S120043502TD	M4*35
A30	SA41740653TB	9/64*40*6.5	B47	S120043501TN	M4*35
A31	SA41741401CN	9/64*40*14	B48	S120044001TN	M4*40
			B49	S120044501TN	M4*45
B Hexagon Socket Head Cap Screw			B50	S120050601TN	M5*6
B1	S120020801TD	M2*8	B51	S120050801TD	M5*8
B2	S120021001TD	M2*10	B52	S120050802TN	M5*8
B3	S120480501TN	M2.6*5	B53	S120051001TD	M5*10
B4	S120030301TN	M3*3	B54	S120051002TN	M5*10
B5	S120030401TN	M3*4	B55	S120051004TP	M5*10
B6	S120030502TD	M3*5	B56	S120051201TD	M5*12
B7	S120030501TN	M3*5	B57	S120051202TN	M5*12
B8	S120030601TD	M3*6	B58	S120051401TN	M5*14
B9	S120030602TN	M3*6	B59	S120051501MZ	M5*15
B10	S120030804MZ	M3*8	B60	S120051502TD	M5*15
B11	S120030801TD	M3*8	B61	S120051503TN	M5*15
B12	S120030802TN	M3*8	B62	S120051601TN	M5*16
B13	S120031001TD	M3*10	B63	S120051801TN	M5*18
B14	S120031002TN	M3*10	B64	S120052001TD	M5*20
B15	S120031203TD	M3*12	B65	S120052002TN	M5*20
B16	S120031201TN	M3*12	B66	S120052201TN	M5*22

B

No.	Part No.	Remark	No.	Part No.	Remark
B	Hexagon Socket Head Cap Screw		B116	S120102002TD	M10*20
B67	S120052301TN	M5*23	B117	S120102001TN	M10*20
B68	S120052501TN	M5*25	B118	S120102501TN	M10*25
B69	S120053001TN	M5*30	B119	S120103001TN	M10*30
B70	S120053503TD	M5*35	B120	S120103501TN	M10*35
B71	S120053501TN	M5*35	B121	S120104001TN	M10*40
B72	S120053502TN	M5*35 Half Threads	B122	S120123001TN	M12*30
B73	S120054001TN	M5*40	B123	S120123501TN	M12*35
B74	S120054501TN	M5*45	B124	S120081801TN	M8*18
B75	S120055001TN	M5*50	B125	S120470501TN	M2.5*5
B76	S120055002TN	M5*50 Half Threads	B126	S120052502TD	M5*25
B77	S120055501TN	M5*55	B127	S120030302TD	M3*3
B78	S120056001TN	M5*60	B128	S120051504TN	M5*15 Low Head
B79	S120056003TN	M5*60 Half Threads	B129	S120031801TD	M3*18
B80	S120060801TN	M6*8	B130	S120052801TN	M5*28
B81	S120060901TN	M6*9	B131	S120044502TN	M4*45 Half Threads
B82	S120061001TN	M6*10	B132	S120081501TD	M8*15
B83	S120061202TD	M6*12	B133	S120051802TD	M5*18
B84	S120061201TN	M6*12	B134	S120470401TN	M2.5*4
B85	S120061501TD	M6*15	B135	S120033003SD	M3*30
B86	S120061502TN	M6*15	B136	S120030402TD	M3*4
B87	S120061801TD	M6*18	B137	S120033002TN	M3*30
B88	S120061802TN	M6*18	B138	S120067502TN	M6*75
B89	S120062001TN	M6*20	B139	S120050501TN	M5*5
B90	S120062501TN	M6*25	B140	S120082001TD	M8*20
B91	S120063001TN	M6*30	B141	S120086002TD	M8*60
B92	S120063501TN	M6*35	B142	S120062002TD	M6*20
B93	S120064001TN	M6*40	B143	S120043503TD	M4*35 Half Threads
B94	S120064501TN	M6*45	B144	S120044003TN	M4*40 Half Threads
B95	S120064502TN	M6*45 Half Threads	B145	S120030605TD	M3*6 Low Head
B96	S120065001TN	M6*50 Half Threads	B146	S120042202TD	M4*22
B97	S120066501TN	M6*65	B147	S120062502TD	M6*25
B98	S120067501TN	M6*75 Half Threads	B148	S120045501TN	M4*55 Half Threads
B99	S120068001TN	M6*80 Half Threads	B149	S120123001TD	M12*30
B100	S12006A001TN	M6*100	B150	S120034001TN	M3*40
B101	S120081201TN	M8*12	B151	S120035001TN	M3*50
B102	S120081502TN	M8*15	B152	S120470502TD	M2.5*5
B103	S120081503TP	M8*15	B153	S120081202TD	M8*12
B104	S120081601TN	M8*16	B154	S120042201TN	M4*22
B105	S120082001TN	M8*20	B155	S120041802TD	M4*18
B106	S120082502TN	M8*25	B156	S120041602TD	M4*16
B107	S120083001TN	M8*30	B157	S120081504TN	M8*15 With Washer
B108	S120083501TN	M8*35	B158	S120050602TD	M5*6
B109	S120084001TN	M8*40	B159	S120045001TD	M4*50
B110	S120084002TN	M8*40 Half Threads	B160	S120044002TD	M4*40
B111	S120084501TN	M8*45	B161	S120082501TD	M8*25
B112	S120084502TN	M8*45 Half Threads	B162	S120040603SC	M4*6 Extra Low Head
B113	S120085001TN	M8*50	B163	S120470301TN	M2.5*3
B114	S120086001TN	M8*60	B164	S120031401TN	M3*14
B115	S120087001TN	M8*70	B165	S123040601TD	M4*6 With Flange

B, C, D, E

No.	Part No.	Remark	No.	Part No.	Remark
B Hexagon Socket Head Cap Screw			D Round Fillister Head Screw		
B166	S123040603MZ	M4*6 With Flange	D1	SA43740401CL	9/64*40*4
B167	S123040801TN	M4*8 With Flange	D2	SA43740501CL	9/64*40*5
B168	S123050601MZ	M5*6 With Flange	D3	SA43740502CN	9/64*40*5
B169	S123050801MZ	M5*8 With Flange	D4	SA43740503CN	9/64*40*5
B170	S123051001MZ	M5*10 With Flange	D5	SA43740504CN	9/64*40*5
B171	S123051201TD	M5*12 With Flange	D6	SA43740601CL	9/64*40*6
B172	S123051202MZ	M5*12 With Flange	D7	SA43740602CN	9/64*40*6
B173	S123060801TD	M6*8 With Flange	D8	SA43740603CL	9/64*40*6
B174	S120053002TD	M5*30	D9	SA43740604CN	9/64*40*6
B175	S120063002TD	M6*30	D10	SA43740682CN	9/64*40*6.8
B176	S120050502TD	M5*5	D11	SA43740801CL	9/64*40*8
B177	S120043002TN	M4*30 Half Threads	D12	SA43740802CN	9/64*40*8
B178	S120020601TN	M2*6	D13	SA43741001CN	9/64*40*10
B179	S120064003TD	M6*40	D14	SA43741201CN	9/64*40*12
B180	S120064503TD	M6*45	D15	SA43750601CN	11/64*40*6
B181	S120066502TD	M6*65	D16	SA43750652CN	11/64*40*6.5
			D17	SA43751051CN	11/64*40*10.5
			D18	SA43751201CN	11/64*40*12
C Hexagon Bolt			D19	SA43751501CN	11/64*40*15
C1	S121030601SD	M3*6	D20	SA43812451CN	9/32*28*24.5
C2	S121040801SD	M4*8	D21	S143030501SD	M3*5
C3	S121042501SD	M4*25			
C4	S121051001SD	M5*10	E Pan Head Screw		
C5	S121051502SC	M5*15	E1	S160410141MZ	M1.4*1.4
C6	S121051501SD	M5*15	E2	S160020202MZ	M2*2
C7	S121052001SD	M5*20	E3	S160020301MZ	M2*3
C8	S121061501SC	M6*15	E4	S160020401MZ	M2*4
C9	S121062501TN	M6*25	E5	S160020801MZ	M2*8
C10	S121064501SD	M6*45	E6	S160470301MZ	M2.5*3
C11	S121065001SC	M6*50	E7	S160470402MZ	M2.5*4
C12	S121065002SD	M6*50	E8	S160470501MZ	M2.5*5
C13	S121065501SD	M6*55	E9	S160470801MZ	M2.5*8
C14	S121066501SD	M6*65	E10	S160471301MZ	M2.5*13
C15	S121067501SC	M6*75	E11	S160471302SD	M2.5*13
C16	S121081501TN	M8*15	E12	S160480601SD	M2.6*6
C17	S121081801TN	M8*18	E13	S160030301MZ	M3*3
C18	S121103001TN	M10*30	E14	S160030302SD	M3*3
C19	S121103502SC	M10*35	E15	S160030403CD	M3*4
C20	S121103501TN	M10*35	E16	S160030401MZ	M3*4
C21	S121104001SC	M10*40	E17	S160030402SD	M3*4
C22	S121125001TN	M12*50	E18	S160030501MZ	M3*5
C23	S12112B001TN	M12*110	E19	S160030502SD	M3*5
C24	S121082501TN	M8*25	E20	S160030601MZ	M3*6
C25	S121102501TN	M10*25	E21	S160030603SA	M3*6
C26	S121082202TN	M8*22	E22	S160030602SD	M3*6
C27	S121041001SD	M4*10	E23	S160030801MZ	M3*8
C28	S121040601SD	M4*6	E24	S160030803SA	M3*8
C29	S121061503SD	M6*15	E25	S160030802SD	M3*8
C30	S121051801SD	M5*18	E26	S160031001MZ	M3*10

E, F

No.	Part No.	Remark	No.	Part No.	Remark
E	Pan Head Screw		E76	S160020501SD	M2*5
E27	S160031003SC	M3*10 Half Threads	E77	S160052501SD	M5*25
E28	S160031002SD	M3*10	E78	S160044001SD	M4*40
E29	S160031101SC	M3*11 Half Threads	E79	S160470403SD	M2.5*4
E30	S160031201MZ	M3*12	E80	S160021201SD	M2*12
E31	S160031202SD	M3*12			
E32	S160031401SA	M3*14	F	Countersunk Head Screw	
E33	S160031402SD	M3*14	F1	SA51741001CN	9/64*40*10
E34	S160031501SD	M3*15	F2	SA50750801CN	11/64*40*8
E35	S160031601SD	M3*16	F3	S150020601SD	M2*6
E36	S160031801SD	M3*18	F4	S150030401MZ	M3*4
E37	S160032001SD	M3*20	F5	S150030402SD	M3*4
E38	S160033001SD	M3*30	F6	S150030501MZ	M3*5
E39	S160034002SD	M3*40	F7	S150030502SD	M3*5
E40	S160035001SD	M3*50 Half Threads	F8	S151030601SD	M3*6
E41	S160040401SD	M4*4	F9	S150030601MZ	M3*6
E42	S160040501SD	M4*5	F10	S150030602SD	M3*6
E43	S160040601MZ	M4*6	F11	S150030701SD	M3*7
E44	S160040602SD	M4*6	F12	S151030801SD	M3*8
E45	S160040801SD	M4*8	F13	S150030801MZ	M3*8
E46	S160041001SD	M4*10	F14	S150030804SC	M3*8
E47	S160041201SD	M4*12	F15	S150030802SD	M3*8
E48	S160041501SD	M4*15	F16	S150030803SN	M3*8
E49	S160041801SD	M4*18	F17	S150031002MZ	M3*10
E50	S160043001SD	M4*30	F18	S150031001SD	M3*10
E51	S160045001SD	M4*50	F19	S150031201MZ	M3*12
E52	S160046001SD	M4*60	F20	S150031202SD	M3*12
E53	S160050601SD	M5*6	F21	S150031501MZ	M3*15
E54	S160050701SD	M5*7	F22	S150031601SD	M3*16
E55	S160050801SD	M5*8	F23	S150040501SD	M4*5
E56	S160051002MZ	M5*10	F24	S150040602MZ	M4*6
E57	S160051001SD	M5*10	F25	S150040601SD	M4*6
E58	S160051201SD	M5*12	F26	S150040801MZ	M4*8
E59	S160053001SD	M5*12	F27	S150040802SD	M4*8
E60	S160051501SD	M5*15	F28	S150041001MZ	M4*10
E61	S160054501SD	M5*45	F29	S150041002SD	M4*10
E62	S160055001SD	M5*50	F30	S150041201SD	M4*12
E63	S160056001SD	M5*60	F31	S150041401SD	M4*14
E64	S160047001SD	M4*70	F32	S150041501SD	M4*15
E65	S160480801SD	M2.6*8	F33	S150042001SD	M4*20
E66	S160030504SC	M3*5	F34	S150042201SD	M4*22
E67	S160480602MZ	M2.6*6	F35	S150042501SD	M4*25
E68	S160031403MZ	M3*14	F36	S150050601SD	M5*6
E69	S160042001SD	M4*20	F37	S150050801SD	M5*8
E70	S160044501SD	M4*45	F38	S150051001MZ	M5*10
E71	S160020203SD	M2*2	F39	S150051002SD	M5*10
E72	S160470502SD	M2.5*5	F40	S150051201SD	M5*12
E73	SA60740551TN	9/64*40*5.5	F41	S150051501SD	M5*15
E74	S160431001MZ	M1.7*10	F42	S150053001SD	M5*30
E75	S160043501SD	M4*35	F43	S150053501SD	M5*35

F, G, H

No.	Part No.	Remark	No.	Part No.	Remark
F Countersunk Head Screw			H23	S130031002SD	M3*10
F44	S150054001SD	M5*40	H24	S130032001SD	M3*20
F45	S150061502SC	M6*15	H25	S130040401MZ	M4*4
F46	S150061503SD	M6*15	H26	S130040401SD	M4*4
F47	S150063501SD	M6*35	H27	S130040501MZ	M4*5
F48	S150081201SD	M8*12	H28	S130040502SD	M4*5
F49	S150087001TN	M8*70	H29	S130040601MZ	M4*6
F50	S150061801SD	M6*18	H30	S130040602SD	M4*6
F51	S150052501SD	M5*25	H31	S130040651SD	M4*6.5
F52	S150040502MZ	M4*5	H32	S130040801MZ	M4*8
F53	S150020301MZ	M2*3	H33	S130040802SD	M4*8
F54	S150020401MZ	M2*4	H34	S130040803MZ	M4*8 JIS
F55	S150480401MZ	M2.6*4	H35	S130041002MZ	M4*10
F56	S150031401SD	M3*14	H36	S130041001SD	M4*10
F57	S150020302MZ	M2*3 0-TYPE 1	H37	S130041201SD	M4*12
			H38	S130041502SD	M4*15
G Round Countersunk Head Screw			H39	S130042001SD	M4*20
G1	SA53730601CL	1/8*44*6	H40	S130050501SD	M5*5
G2	SA53740301CL	9/64*40*3	H41	S130050602MZ	M5*6
G3	SA53740351CL	9/64*40*3.5	H42	S130050601SD	M5*6
G4	SA53740401CL	9/64*40*4	H43	S130050651SD	M5*6.5
G5	SA53740601CL	9/64*40*6	H44	S130050701SD	M5*7
G6	SA53740701CL	9/64*40*7	H45	S130050801MZ	M5*8
G7	SA53740951CL	9/64*40*9.5	H46	S130050802SD	M5*8
G8	SA53741201CL	9/64*40*12	H47	S130051002MZ	M5*10
G9	SA53740681CL	9/64*40*6.8	H48	S130051001SD	M5*10
			H49	S130051201MZ	M5*12
H Truss Head Screw			H50	S130051202SD	M5*12
H1	SA30730701CL	1/8*44*7	H51	S130051501SD	M5*15
H2	SA30740301CL	9/64*40*3.5	H52	S130052001SD	M5*20
H3	SA30740401CL	9/64*40*4	H53	S130052502SD	M5*25
H4	SA31740401CM	9/64*40*4	H54	S130053001SD	M5*30
H5	SA30740601CL	9/64*40*6	H55	S130053501SD	M5*35
H6	SA30740801CL	9/64*40*8	H56	S130060801SD	M6*8
H7	S130470301MZ	M2.5*3	H57	S130061001SD	M6*10
H8	S130470302SD	M2.5*3	H58	S130062201SD	M6*22
H9	S130470401MZ	M2.5*4	H59	S130062501SD	M6*25
H10	S130470402SA	M2.5*4	H60	S130063501SD	M6*35
H11	S130470403SD	M2.5*4	H61	S130064001SD	M6*40
H12	S130030301MZ	M3*3	H62	S130031501SD	M3*15
H13	S130030302SD	M3*3	H63	S130043501SD	M4*35
H14	S130030402SD	M3*4	H64	S130020201SD	M2*2
H15	S130030501MZ	M3*5	H65	S130470501SD	M2.5*5
H16	S130030502SD	M3*5	H66	S130052002MZ	M5*20
H17	S130030601MZ	M3*6	H67	S130054501SE	M5*45
H18	S130030602SD	M3*6	H68	S130050502MZ	M5*5
H19	S130030603SA	M3*6	H69	S130054001SD	M5*40
H20	S130030802SD	M3*8	H70	S130055001SD	M5*50
H21	S130030803SA	M3*8	H71	S130030801MZ	M3*8
H22	S130031001MZ	M3*10	H72	S130052201SD	M5*22

H, J, K, L, M

No.	Part No.	Remark	No.	Part No.	Remark
H	Truss Head Screw		<i>L16</i>	S170040301TN	M4*3
<i>H73</i>	S130041802MZ	M4*18	<i>L17</i>	S170040401TN	M4*4
<i>H74</i>	S130055501SD	M5*55	<i>L18</i>	S170040501TN	M4*5
<i>H75</i>	S130041202SD	M4*12 JIS	<i>L19</i>	S170040601TN	M4*6
<i>H76</i>	SA30740501CL	9/64*40*5	<i>L20</i>	S170040602TN	M4*6 Half Threads
<i>H77</i>	SA30741001CL	9/64*40*10	<i>L21</i>	S170040801TN	M4*8
<i>H78</i>	S130041203MZ	M4*12	<i>L22</i>	S170041001TN	M4*10
			<i>L23</i>	S170041201TN	M4*12
J	Round Head Screw		<i>L24</i>	S170050401TN	M5*4
<i>J1</i>	S162020301MZ	M2*3	<i>L25</i>	S170050501TN	M5*5
<i>J2</i>	S162030801SD	M3*8	<i>L26</i>	S170050601TN	M5*6
<i>J3</i>	S162030802SE	M3*8	<i>L27</i>	S170050801TN	M5*8
<i>J4</i>	S162031001MZ	M3*10	<i>L28</i>	S170051001TN	M5*10
			<i>L29</i>	S170051201TN	M5*12
K	Slotted Set Screw		<i>L30</i>	S170051501TN	M5*15
<i>K1</i>	SA71730351CN	1/8*44*3.5	<i>L31</i>	S170060501TN	M6*5
<i>K2</i>	SA71740601CN	9/64*40*6	<i>L32</i>	S170060601TN	M6*6
<i>K3</i>	SA71750251CN	11/64*40*2.5	<i>L33</i>	S170060801TN	M6*8
<i>K4</i>	SA71750351CN	11/64*40*3.5	<i>L34</i>	S170061001TN	M6*10
<i>K5</i>	SA71750401CN	11/64*40*4	<i>L35</i>	S170061801TN	M6*18
<i>K6</i>	SA71750501CN	11/64*40*5	<i>L36</i>	S170080801TN	M8*8
<i>K7</i>	SA71790501CN	15/64*28*5	<i>L37</i>	S170081001TN	M8*10
<i>K8</i>	SA71791001CN	15/64*28*10	<i>L38</i>	S170081501TN	M8*15
<i>K9</i>	SA71791501CN	15/64*28*15	<i>L39</i>	S170031001TN	M3*10
<i>K10</i>	SA71791701CN	15/64*28*17	<i>L40</i>	S170031201TN	M3*12
<i>K11</i>	SA71800401CN	1/4*40*4	<i>L41</i>	S170053001TN	M5*30
<i>K12</i>	SA71800451CN	1/4*40*4.5	<i>L42</i>	S170061201TN	M6*12
<i>K13</i>	SA71800501CN	1/4*40*5	<i>L43</i>	S174060601TN	M6*6B
<i>K14</i>	SA71800601CN	1/4*40*6	<i>L44</i>	S170050802TN	M5*8 Narrow Treading
<i>K15</i>	SA71800801CN	1/4*40*8	<i>L45</i>	S170050602TN	M5*6 Narrow Treading
<i>K16</i>	SA71811201CN	9/32*28*12	<i>L46</i>	S170031501TN	M3*15
<i>K17</i>	S171050601TN	M5*6	<i>L47</i>	S170061501TN	M6*15
<i>K18</i>	S171030601SD	M3*6	<i>L48</i>	S170080601TN	M8*6
L	Hexagon Socket Head Set Screw		M	Hexagon Socket Head Button Screw	
<i>L1</i>	SA70730251CN	1/8*44*2.5	<i>M1</i>	S124030401SC	M3*4
<i>L2</i>	SA70730301CN	1/8*44*3	<i>M2</i>	S124040601SC	M4*6
<i>L3</i>	SA70750901CN	11/64*28*9	<i>M3</i>	S124040802SC	M4*8
<i>L4</i>	SA70750401CN	11/64*40*4	<i>M4</i>	S124040803SD	M4*8
<i>L5</i>	SA70750601CN	11/64*40*6	<i>M5</i>	S124051001SC	M5*10
<i>L6</i>	SA70750801CN	11/64*40*8	<i>M6</i>	S124051002SD	M5*10
<i>L7</i>	SA70790401CN	15/64*28*4	<i>M7</i>	S124051501SD	M5*15
<i>L8</i>	SA70790901CN	15/64*28*9	<i>M8</i>	S124081201SC	M8*12
<i>L9</i>	S170470301TN	M2.5*3	<i>M9</i>	S124081202SD	M8*12
<i>L10</i>	S170030201TN	M3*2	<i>M10</i>	S124081501SD	M8*15
<i>L11</i>	S170030301TN	M3*3	<i>M11</i>	S124030501SC	M3*5
<i>L12</i>	S170030401TN	M3*4	<i>M12</i>	S124030801SC	M3*8
<i>L13</i>	S170030501TN	M3*5	<i>M13</i>	S124030502TC	M3*5
<i>L14</i>	S170030601TN	M3*6	<i>M14</i>	S124030402SD	M3*4
<i>L15</i>	S170030801TN	M3*8	<i>M15</i>	S124030601SD	M3*6

M, N, P

No.	Part No.	Remark	No.	Part No.	Remark
M	Hexagon Socket Head Button Screw		N42	S660030803S1	M3*8 (P-4)
M16	S124040401SD	M4*4	N43	S660031201S1	M3*12 (P-3)
M17	S124030602SC	M3*6	N44	S620041001TD	M4*10 Hexagon Socket Head
M18	S124030503SD	M3*5			
M19	S124031002SD	M3*10	P Nut		
M20	S124041001SD	M4*10	P1	SB10730601CN	1/8*44*6*3
M21	S124051201SD	M5*12	P2	SB10740601CL	9/64*40*6*2
			P3	SB10740602CN	9/64*40*6*3
N	Screw with Washer		P4	SB10750602CN	11/64*40*6*2
N1	S660480601SE	M2.6*6	P5	SB10750603CN	11/64*40*6*3
N2	S660030601SE	M3*6	P6	SB10750701CN	11/64*40*7*3
N3	S660030801SE	M3*8	P7	SB11750701CN	11/64*40*7*3
N4	S660031001SE	M3*10	P8	S210420001XA	M1.6 Type 1
N5	S660031501SE	M3*15	P9	S210020001SD	M2 Type 1
N6	S660031601SE	M3*16	P10	S212020002SD	M2 Type 3
N7	S660031801SE	M3*18	P11	S210460002SD	M2.3 Type 1
N8	S660040601SE	M4*6	P12	S210470001MZ	M2.5 Type 1
N9	S660040801SE	M4*8	P13	S212480001SD	M2.6 Type 3
N10	S660041001SE	M4*10	P14	S210030001MZ	M3 Type 1
N11	S660041201SE	M4*12	P15	S210030002SC	M3 Type 1
N12	S660045501SE	M4*55	P16	S210030003SD	M3 Type 1
N13	S660051001SE	M5*10	P17	S215030001SD	M3 Thumbscrew Type 2
N14	S660051201SE	M5*12	P18	S212030001SC	M3 Type 3
N15	S660051401SE	M5*14	P19	S212030002SD	M3 Type 3
N16	S660051801SE	M5*18	P20	S212530001SC	M3.5 Type 3
N17	S660030801MZ	M3*8	P21	S210040001SC	M4 Type 1
N18	S660030502MZ	M3*5	P22	S210040002SD	M4 Type 1
N19	S660031502MZ	M3*15	P23	S212040001SC	M4 Type 3
N20	S660030603S1	M3*6 (P-4)	P24	S212040002SD	M4 Type 3
N21	S660030802S1	M3*8 (P-3)	P25	S217040001SD	M4 Cap
N22	S660030604S1	M3*6 (P-3)	P26	S210050001SC	M5 Type 1
N23	S660031802S1	M3*18 (P-3)	P27	S210050002SD	M5 Type 1
N24	S660040602S1	M4*6 (P-3)	P28	S212050001SC	M5 Type 3
N25	S660040802S1	M4*8 (P-3)	P29	S212050002SD	M5 Type 3
N26	S660041002S1	M4*10 (P-3)	P30	S217050001SD	M5 Cap
N27	S660043001S1	M4*30 (P-3)	P31	S210060001SC	M6 Type 1
N28	S660051002S1	M5*10 (P-3)	P32	S210060002SC	M6 Type 1 (Left)
N29	S660031803S1	M3*18 (P-4)	P33	S210060003SD	M6 Type 1
N30	S660030505S1	M3*5 (P-4)	P34	S210060004SD	M6 Type 1 (Left)
N31	S660031504S1	M3*15 (P-4)	P35	S212060001SC	M6 Type 3
N32	S660031002S1	M3*10 (P-4)	P36	S210080001SC	M8 Type 1
N33	S660040803S1	M4*8 (P-4)	P37	S210080002SD	M8 Type 1
N34	S660030504S1	M3*5 (P-3)	P38	S212080001SC	M8 Type 3
N35	S660020401S1	M2*4 (P-4)	P39	S212080002SD	M8 Type 3
N36	S660031505S1	M3*15 (P-3)	P40	S210100001SC	M10 Type 1
N37	S660041202S1	M4*12 (P-3)	P41	S213100002SD	M10 With Flange
N38	S660480401S1	M2.6*4 (P-4)	P42	S213100003SD	M10 With Disk Spring
N39	S660031003S1	M3*10 (P-3)	P43	S210120001SC	M12 Type 1
N40	S660031602S1	M3*16 (P-3)	P44	S212120001SC	M12 Type 3
N41	S660030605S1	M3*6 (P-3) FOR THIN PLATE	P45	S212120002SD	M12 Type 3

P, R

No.	Part No.	Remark	No.	Part No.	Remark
P	Nut		R28	S301061102SC	Plain M6*11*t1.6
P46	S210160001SD	M16 Type 1	R29	S301061151SC	Plain M6*11.5*t0.8
P47	S212160002SC	M16 Type 1	R30	S301061301SC	Plain M6*13*t1.0
P48	S212160001SD	M16 Type 3	R31	S301061302SD	Plain M6*13*t1.0
P49	S210200001SC	M20 Type 1	R32	S301061601SC	Plain M6*16*t1.0
P50	S212470001SC	M2.5 Type 3	R33	S301081601SD	Plain M8*16*t1.2
P51	SB12750701SC	11/64*7*2.2 Type 3	R34	S301081801SC	Plain M8*18*t1.6
P52	S211040001SD	M4 Type 2	R35	S301081802SD	Plain M8*18*t1.6
P53	SB12740601MZ	9/64*6*2 Type 3	R36	S301081803SC	Plain M8*18*t3.2
P54	SB10750601CN	11/64*6*2.2	R37	S301082201SC	Plain M8*22*t3.2
P55	S212030003SD	M3 Type 3	R38	S301102201SC	Plain M10*22*t1.6
P56	S217060001SD	M6 Cap	R39	S301102601SC	Plain M10*26*t3.2
P57	S217030001SD	M3 Cap	R40	S301102602SD	Plain M10*26*t3.2
P58	S212200001SC	M20 Type 3	R41	S301122051SC	Plain M12*20.5*t2
P59	S212160002SC	M16 Type 3	R42	S301163201SD	Plain M16*32*t2.5
P60	SB10750702CN	11/64*7*2.2	R43	S402020001KD	Spring M2
P61	SB10740605CN	9/64*40*6*1.5	R44	S402480001KC	Spring M2.6
P62	S213080002SD	M8 With Flange	R45	S402030001KC	Spring M3
P63	S213080001SD	M8 With Disk Spring	R46	S402030002KD	Spring M3
P64	S212100001SC	M10 Type 3	R47	S402530001KC	Spring M3.5
P65	S212060003SD	M6 Type 3	R48	S402040001KC	Spring M4
			R49	S402040002KD	Spring M4
R	Washer		R50	S402050001KC	Spring M5
R1	S301410301MZ	Plain M1.4*3*t0.3	R51	S402050002KD	Spring M5
R2	S301020351XZ	Plain M2*3.5*t0.5	R52	S402050003MZ	Spring M5
R3	S301020431SD	Plain M2*4.3*t0.3	R53	S402060001KC	Spring M6
R4	S301480501XB	Plain M2.6*5*t0.5	R54	S402060002KD	Spring M6
R5	S301480751XB	Plain M2.6*7.5*t0.5	R55	S402080001KC	Spring M8
R6	S301030602XZ	Plain M3*6*t0.3	R56	S402080002KD	Spring M8
R7	S301030603SC	Plain M3*6*t0.5	R57	S402100001KC	Spring M10
R8	S301030601SD	Plain M3*6*t0.5	R58	S402100002KD	Spring M10
R9	S301030701SD	Plain M3*7*t0.5	R59	S402120001KC	Spring M12
R10	S301030804SD	Plain M3*8*t0.3	R60	S305041101TP	Wave M4
R11	S301030805MZ	Plain M3*8*t0.5	R61	S305051001TN	Wave M5
R12	S301030801SC	Plain M3*8*t0.5	R62	S305061051TN	Wave M6
R13	S301030802SD	Plain M3*8*t0.5	R63	S304040851TP	With teeth M4
R14	S301030803SD	Plain M3*8*t1	R64	S304051001TP	With teeth M5
R15	S301040805SC	Plain M4*8*t0.5	R65	S306080001SC	Slant M8
R16	S301040802SD	Plain M4*8*t0.5	R66	S303040801SC	Disk Spring M4
R17	S301040804SC	Plain M4*8*t0.8	R67	S301041005EZ	Plain M4*10*t0.8
R18	S301040803SD	Plain M4*8*t0.8	R68	S301470252MZ	Plain M2.5*5*t0.5
R19	S301041004MZ	Plain M4*10*t0.8	R69	S301030605SD	Plain M3*6*t1.0
R20	S301041002SC	Plain M4*10*t0.8	R70	S301030604MZ	Plain M3*6*t0.5
R21	S301041003SD	Plain M4*10*t0.8	R71	S305051101TN	Wave M5
R22	S301041201SC	Plain M4*12*t1	R72	S301470253SD	Plain M2.5*5*t0.5
R23	S301051002SC	Plain M5*10*t0.8	R73	S301470251SC	Plain M2.5*5*t0.5
R24	S301051003SD	Plain M5*10*t0.8	R74	S305101451TN	Wave M10
R25	S301051204MZ	Plain M5*12*t0.8	R75	S304080001TP	With teeth M8
R26	S301051202SC	Plain M5*12*t0.8	R76	S301061152SD	Plain M6*11.5*t0.8
R27	S301051203SD	Plain M5*12*t0.8	R77	S301122601SC	Plain M12*26*t2.3

1st Edition December, 2015

7th Edition May, 2021

■ **Manufactured by : TISM Co.,Ltd.**

Address : NO.1800, Ushiyama-cho, Kasugai, Aichi-pref., 486-0901, Japan

TEL : 81-568-33-1161 FAX : 81-568-33-1191

■ **Distributed by : Tajima Industries Ltd.**

Address : NO.1800, Ushiyama-cho, Kasugai, Aichi-pref., 486-0901, Japan

TEL : 81-568-37-1130 FAX : 81-568-37-1230

●**Copy, reprint, or reform of a part or whole of this manual without permission is prohibited.**

