

PENSKE
RACING SHOCKS

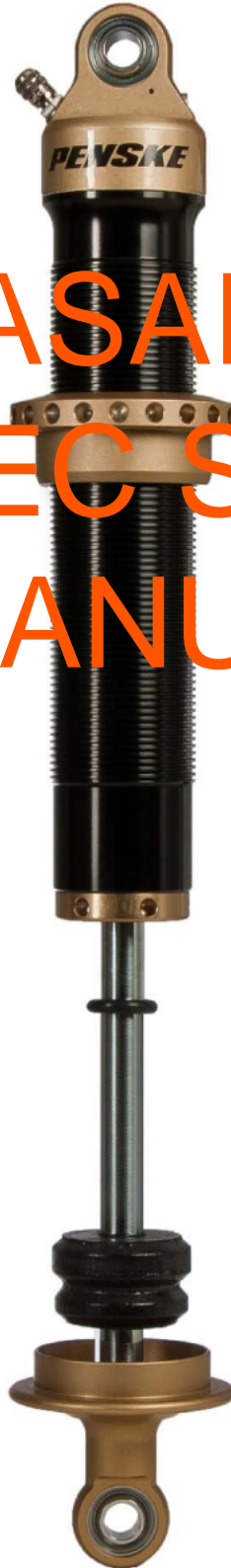

2022 NASCAR MEXICO
SPEC SHOCK
MANUAL



REV 3-11-22

P# PS75CODANM

SHOCKDESCRIPTION 500SERIES DOUBLEADJUSTABLE COIL
OVERSHOCK.

SHOCKCOST \$445.00

PARTS LIST

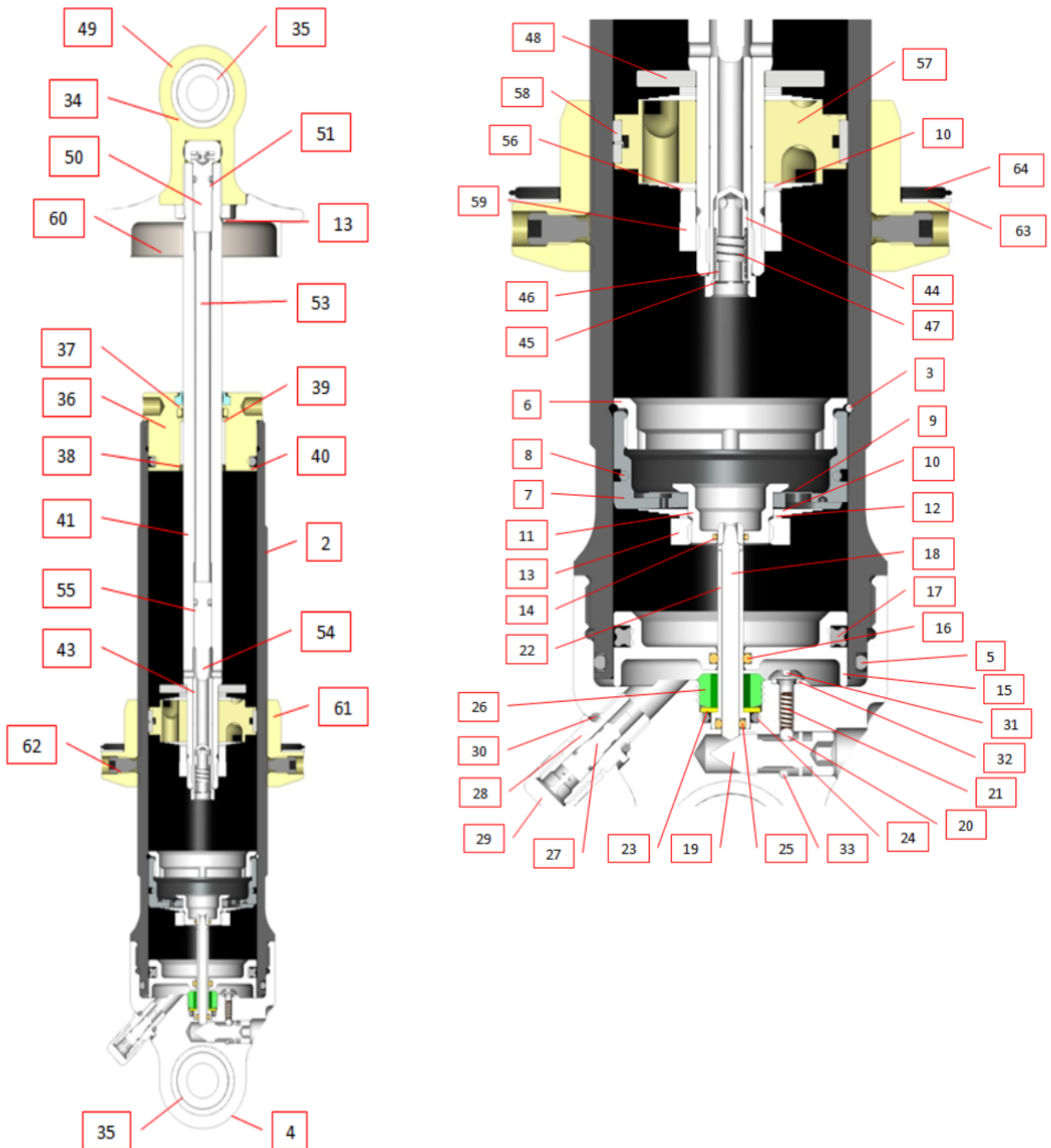

KEY	PART NUMBER	DESCRIPTION
2	BD-7560CO-DA	BODY, 7500 C/O
3	RR 06	WIRE RING, .0625 WIRE DIAMETER X 1.900"
4	BC-75DA-BLK	BODY CAP, 7500 DOUBLE ADJUSTABLE
5	OR 2133 B	O RINGBUNA,70 DUROMETER
6	CO-75HV-ST	COLLAR, 7500 SERIES HV3 VALVE
7	PI 75HV	PISTON, 7500 SERIES HV 3 PORT
8	OR-2029-V	O RINGBUNA,70 DUROMETER
9	VS- SEE PG 5	RETURN SHIM STACK
10	VS- SEE PG 5	VALVE STACK, COMPRESSOR REBOUND
11	SC 75HV DA	SCREW, 7500 DA HEAD VALVE
12	VW 75020 625	WASHER, .750 X .020 X .625 VALVE
13	NT 04J	JAM NUT, .625 X 18
14	OR-2008-V	O RING, 5 MM X 1 MM, VITON
15	PI 75 DA	PISTON, 7500 DOUBLE ADJ FLOATING
16	OR 2008 V	O RINGVITON,70 DUROMETER, BROWN
17	OR 4221 B	QUAD RING, BUNA,70 DUROMETER
18	NE-759-DA	NEEDLE, 7500 DOUBLE ADJUSTABLE
19	RS 73	REBOUND SCREW, 7500
20	BA 093 ST	BALL, 3/32 STEEL
21	SP 36	SPRING
22	FT-759-DA	FITTING, 7500 DOUBLE ADJUSTABLE
23	VW 75 DA	WASHER, 7500 DOUBLE ADJUSTABLE
24	OR 2011 B	O RINGBUNA,70 DUROMETER
25	OR3MMX1.5MMV	O RING, 3MM X 1.5MM, VITON
26	SC 75 DA	SCREW, 7500 DA HOL LOCK SOCKET 500
27	IU 04	VALVE CORE, 2000 PSI
28	IU 22 S	AIR VALVEPORTO RING, S.S.
29	IU 06	VALVE CAP, HIGHTEMPERATURE
30	OR 2010 B	O RINGBUNA,70 DUROMETER
31	SC 75	SCREW, BUTTONHEAD 6/32 X 1/8"
32	OR3.5MMX1MM	O RINGVITON
33	DO 18	ROLL PIN, 1/16 X 1/2
34	RR 16	RET RING, 1.025 SPIROLOC, STAINLESS
35	MO-09	MONOBALL, .500 ID X 1.00 OD
36	SB R53	SHAFT BEARING, 8760
37	SL 09	SHAFT WIPER, .625 POLY (BLUE)
38	BU-10DU06	BUSHINGDU .625 X .625
39	OR 2114 V	O RINGVITON,75 DUROMETER
40	OR 2221 B	O RINGBUNA,70 DUROMETER
41	SH-175A	SHAFT, 7500 ADJ

43	JT RDHSNG	JET, RD STRAIGHT THRU
44	JT 76POP	JET, POPPET
45	RR 05	RETAINING RING, .250 INTERNAL
46	JT 76HAT	JET, TOP HAT
47	SP 15	SPRING
48	VW 99	TOP OUT PLATE, 1.375 X .500
49	EY-75160-S	EYELET, 7500
50	RS 81	REBOUND SCREW, ADJ SHAFT
51	OR 2008 B	O RINGBUNA,70 DUROMETER
53	MR ROD	METERING ROD
54	NE 76	NEEDLE, 8760
55	OR 2007 B	O RINGBUNA,70 DUROMETER
56	VW 75020	WASHER, .750 X .020 X .500 VALVE
57	PI HF12005	PISTON, 55MM,1°2°HIGH FLOW
58	PB 55	PISTON BAND, 55MM
59	NT 02R	RING NUT, .500 X 20, .440 LONG
60	SR 75250 S	SPRING RETAINER, 7500 SILVER
61	RH 83250	RIDE HEIGHT, 8300
62	SCM6M8S	SCREW, GRUB M6MMNYLON

DAMPING LEVELS

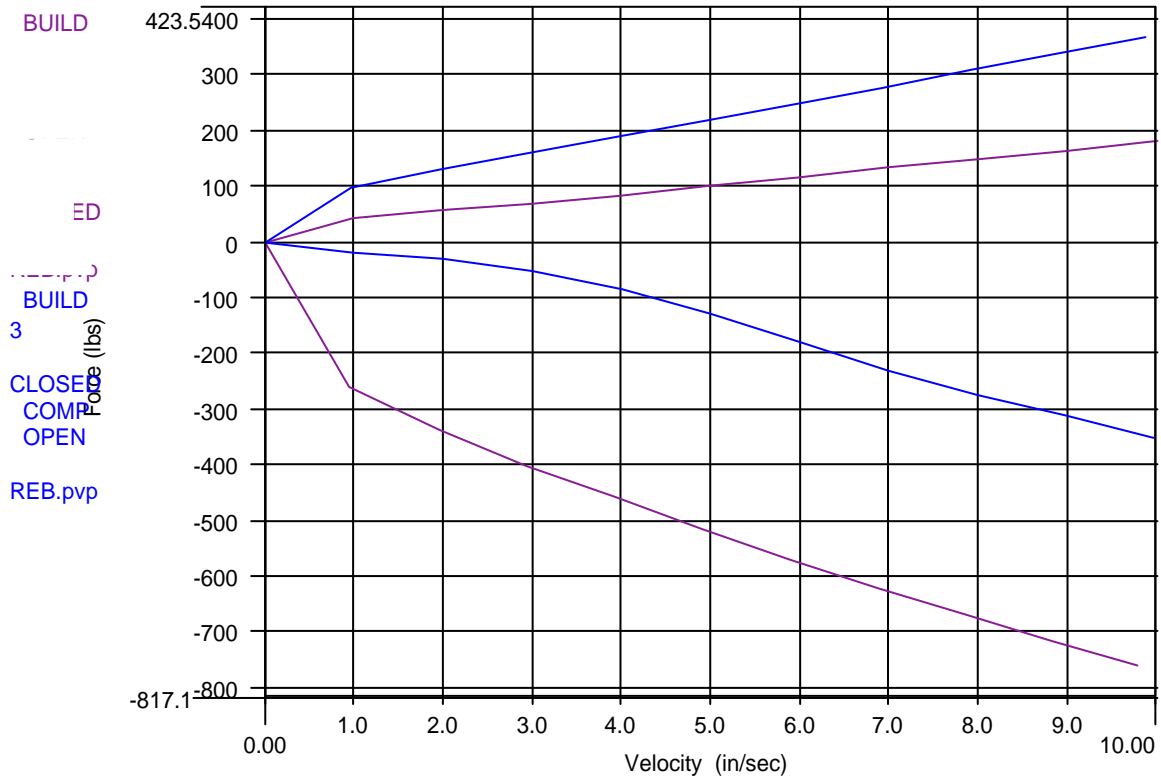

VALVING CODE

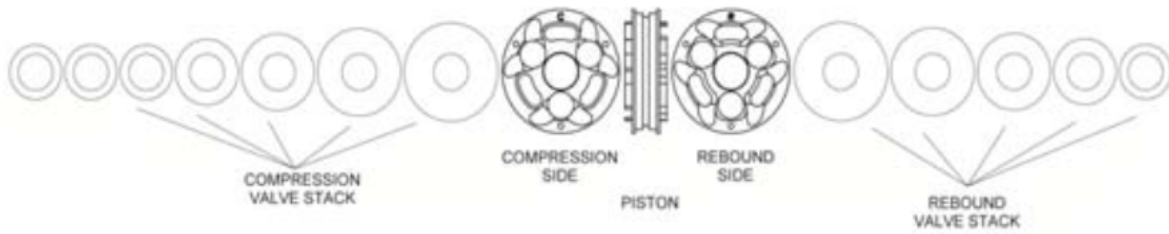

COMPRESSION			REBOUND		
DIAMETER	THICKNESS	QTY	DIAMETER	THICKNESS	QTY
1.350	0.006	1	1.350	0.012	1
1.200	0.006	1	1.200	0.012	1
1.050	0.008	1	1.050	0.012	1
0.900	0.008	1	0.900	0.012	1
0.750	0.020	3	0.750	0.020	1

HEAD VALVE SHIM STACK

COMPRESSION			REBOUND		
DIAMETER	THICKNESS	QTY	DIAMETER	THICKNESS	QTY
0.750	0.750	1	1.235	0.004	2
1.350	0.020	3	0.900	0.010	1
1.350	.012 RNG	1	0.750	0.010	1
1.200	.004 PL	1			
1.350	0.006	1			

**ALL SHIMS ARE .625"ID