

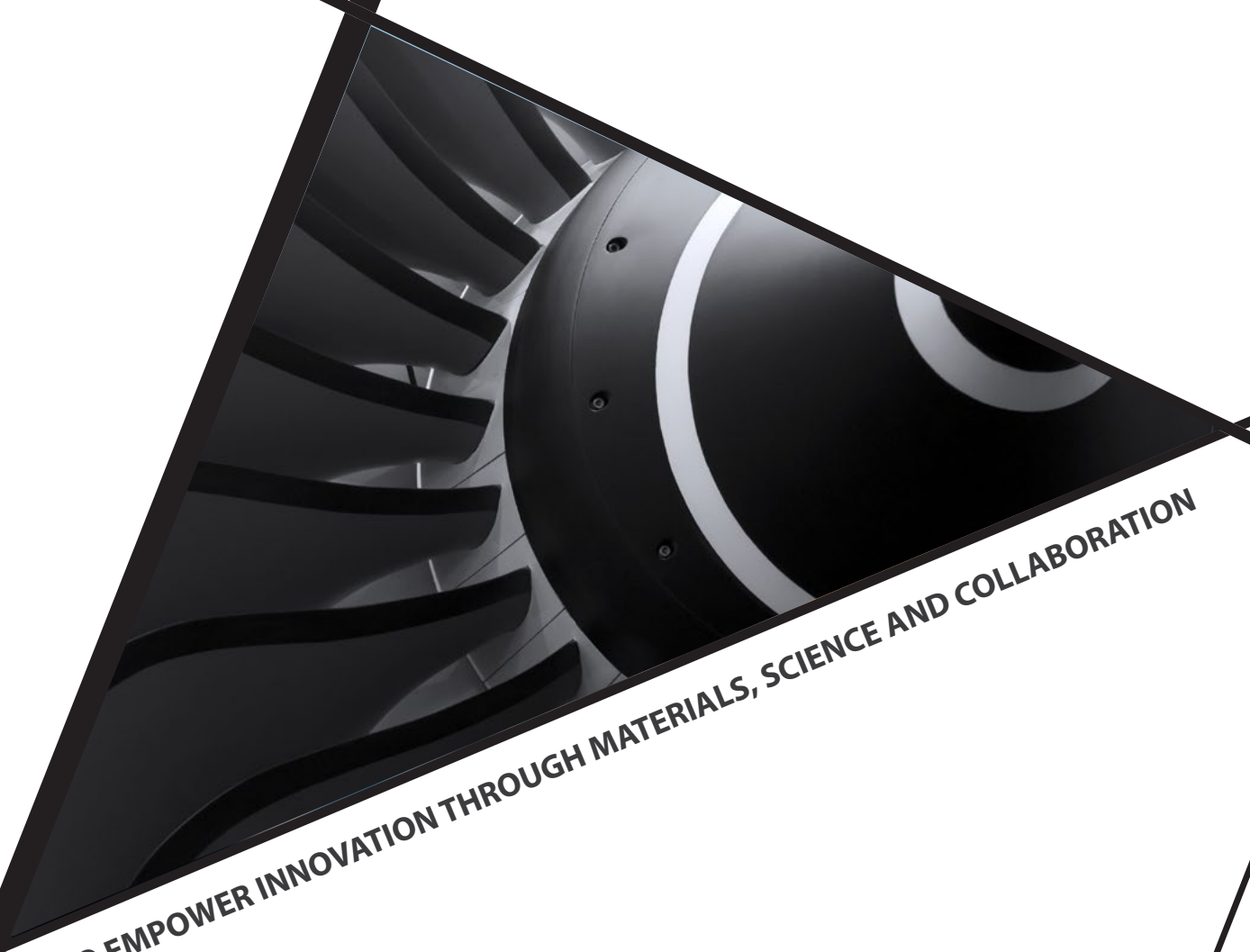

**ZT**<sup>®</sup>  
zippertubing

ISO 9001 | IATF 16949



TO EMPOWER INNOVATION THROUGH MATERIALS, SCIENCE AND COLLABORATION

# About Us

Since 1957, we have been a leader in cable and component protection technologies, collaborating with our customers to overcome the most difficult challenges in the industry. We serve nearly every manufacturing segment and provide solutions to customers worldwide. With manufacturing facilities located in Asia, North America, and Europe, we offer domestic support anywhere in the world.

Continuous improvement and investment in technology drive our business forward as we endeavor to provide high-quality solutions. At Zippertubing®, we strive to be a valued and integrated resource in our customers' design processes. Our multi-discipline Engineering team is focused on creating specific solutions for every application.

With several employee and community-focused programs, we are dedicated to creating a rewarding place to work that all of our employees are proud to be a part of.

## Our Mission

To empower innovation through materials, science and collaboration.

### North America

**The Zippertubing® Co.**  
Chandler, Arizona  
855.289.1874  
www.zippertubing.com

**ZT Labels™**  
Tempe, Arizona  
866.947.8273  
www.ztlabels.com

**Techlite® Acoustic / Insulation**  
Tempe, Arizona  
800.922.5252  
www.techlite.com



### Germany

**Zipper-Technik, GmbH**  
Neu-Isenburg, Germany  
49.6102.73870  
www.zipper-technik.de



### Switzerland

**Ticon, GmbH**  
Bütschwil, Switzerland  
41.71.983.0075  
www.ticongmbh.ch



### China

**ZT-China**  
Guangdong Province,  
P.R. China  
0086.756.3621377  
www.zt-china.com



### Japan

**Zippertubing® (Japan) Ltd.**  
Nishi-ku, Kobe, Japan  
81.6.6341.9545  
www.ztj.co.jp



Corporate Headquarters

Chandler, Arizona



**ZT** | zippertubing®

- Custom Engineering ..... 4
- Capabilities ..... 6
- Cable Bundling ..... 8
- EMI Shielding ..... 10
- Heat Shielding ..... 12
- Heat Shrink ..... 14

# Custom Engineering

Since 1957, Zippertubing® has been manufacturing custom solutions for a wide range of component challenges. From under the sea to outer space, we have prototyped, built, and shipped custom-engineered solutions for virtually every type of industry and application. We specialize in creating custom products in-house from beginning to end, ensuring you receive the perfect solution for your specific application.

Based on our decades of experience in manufacturing, we understand not every application requires the same material, shielding, closure, size, or shape. Our wide range of manufacturing capabilities paired with our industry-leading Engineering team allows us to provide the most customized heat shielding, cable bundling, EMI shielding, or specialized heat shrink solutions.

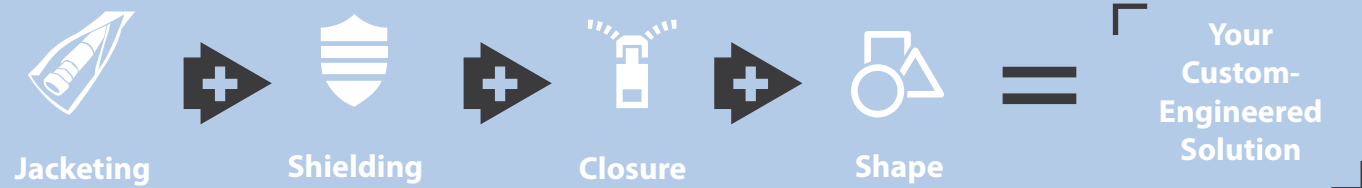

# Engineering Team

The collective expertise of our in-house engineering team can provide you with endless ways to solve your component issues and create a solution — from initial concept to final product.



**TIM MEAD**  
GENERAL MANAGER



**MATT HESSELBACHER**  
PRINCIPAL ENGINEER



**DAVE WENZLICK**  
PRINCIPAL R&D ENGINEER



**JONATHAN SPEIRS**  
SENIOR PRODUCTION ENGINEER



**MADISON LENSCHOW**  
DESIGN ENGINEER II



**HENRY SHROCK**  
DESIGN ENGINEER



**McKENNA ROTH**  
DESIGN ENGINEER



**BRITTANY STANN**  
MATERIALS ENGINEER



**RIC FIX**  
MANUFACTURING ENGINEER

Speak to one of our engineers today! [855.289.1874](tel:855.289.1874)

# Capabilities

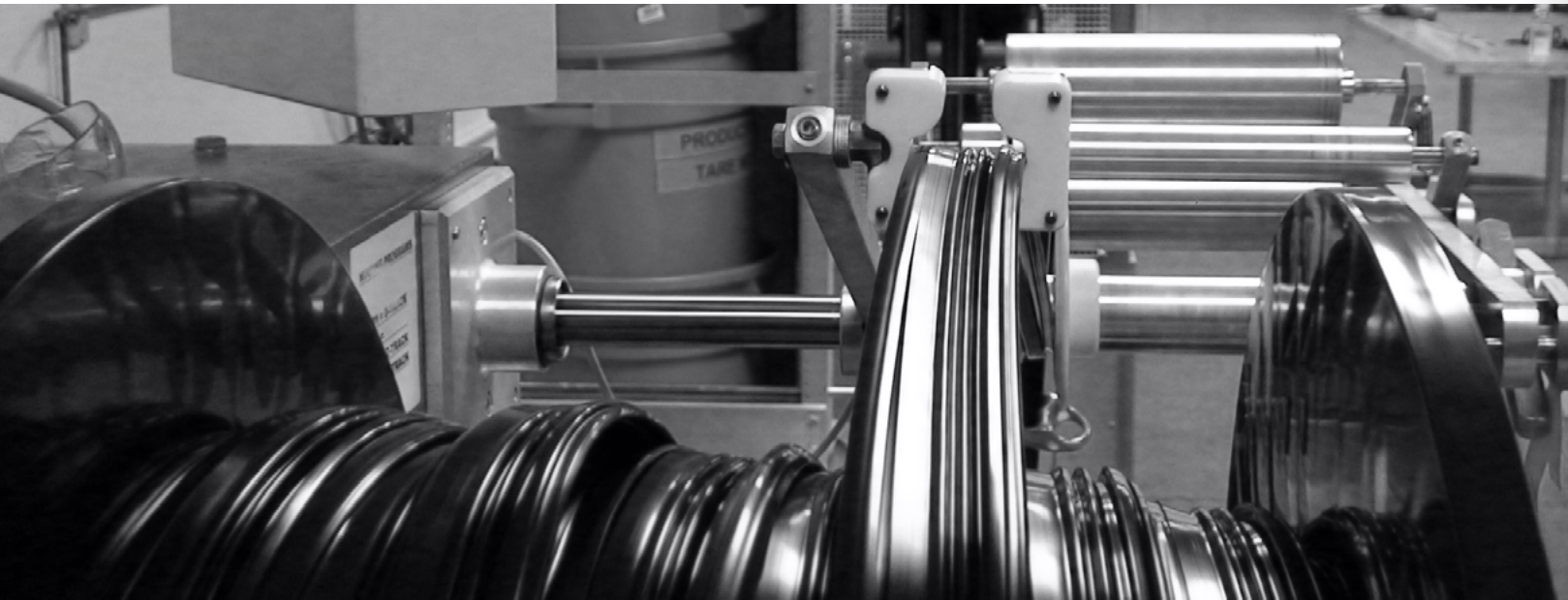

Because of Zippertubing's endless capabilities, we will work with you to develop a prototype solution. Zippertubing® is continually sourcing new materials and closures while developing new methods and creative solutions to help resolve your component issues.



-  In-House Engineering Team
-  RF & Heat Sealing
-  Automated Assembly Machinery
-  Automated Knitting/Braiding
-  Extruded Films/Tracks
-  CNC Cutting System (Laser/Knife)
-  Industrial Sewing/Assembly
-  Custom Lamination
-  Custom White Labeling
-  Automated Die Cutting

# Full-Service Solutions

## Engineer • Prototype • Manufacture

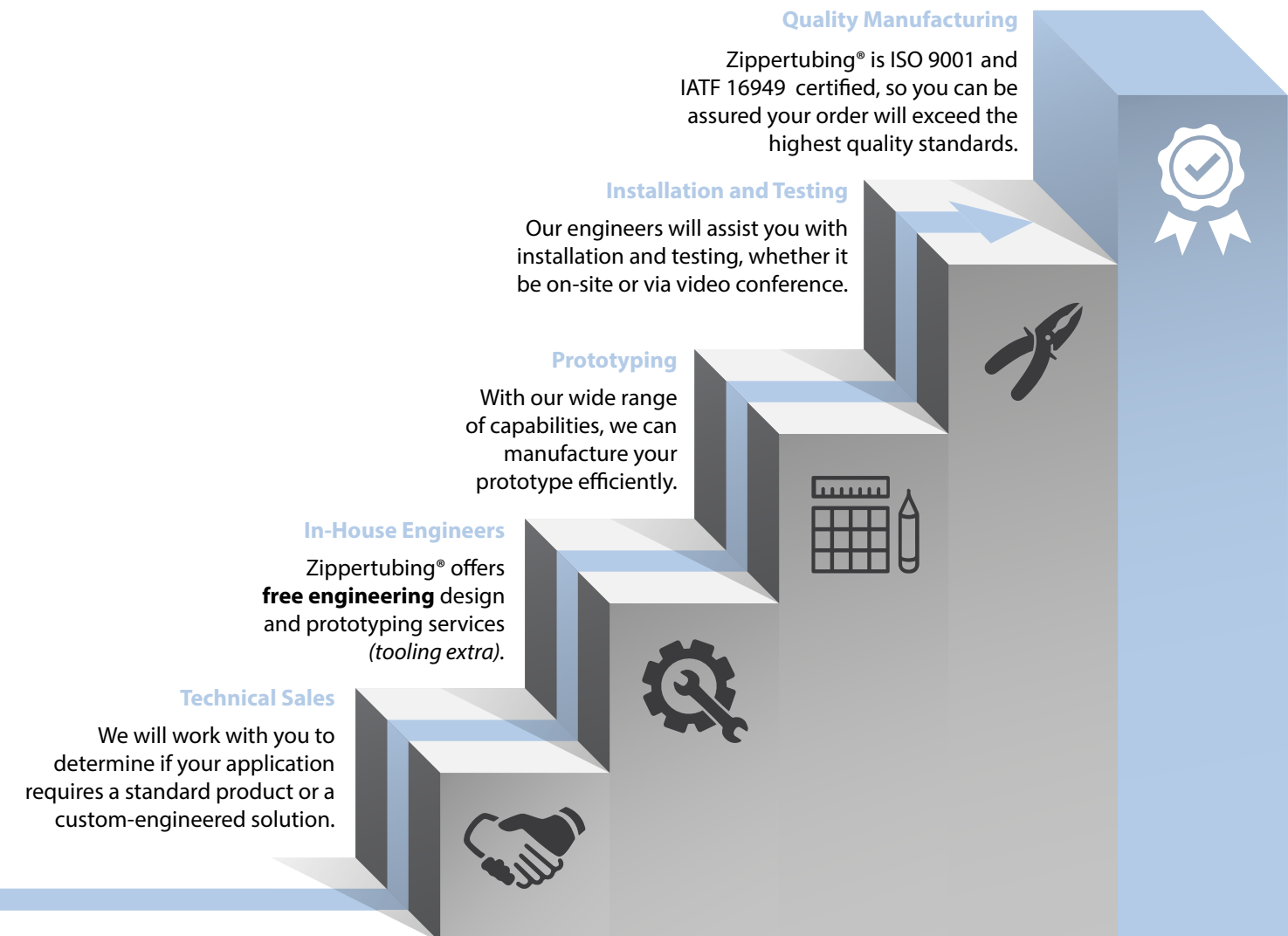

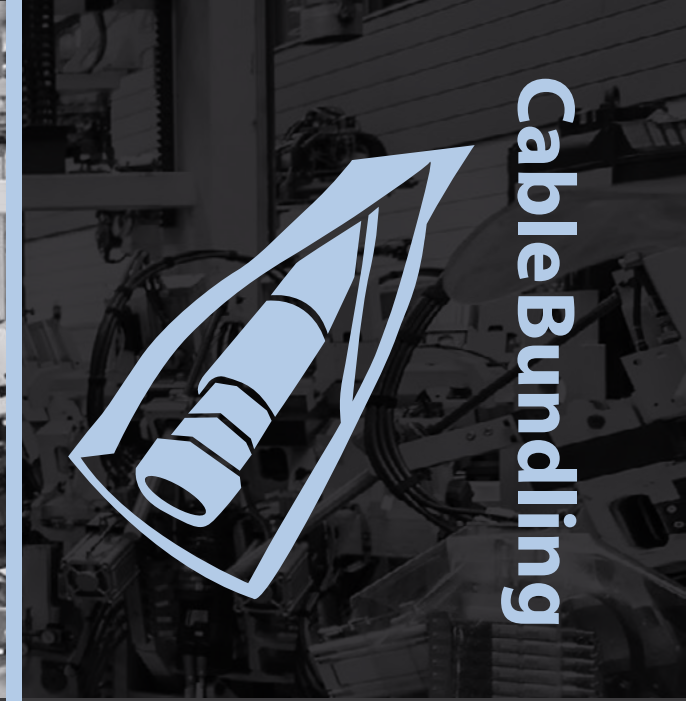
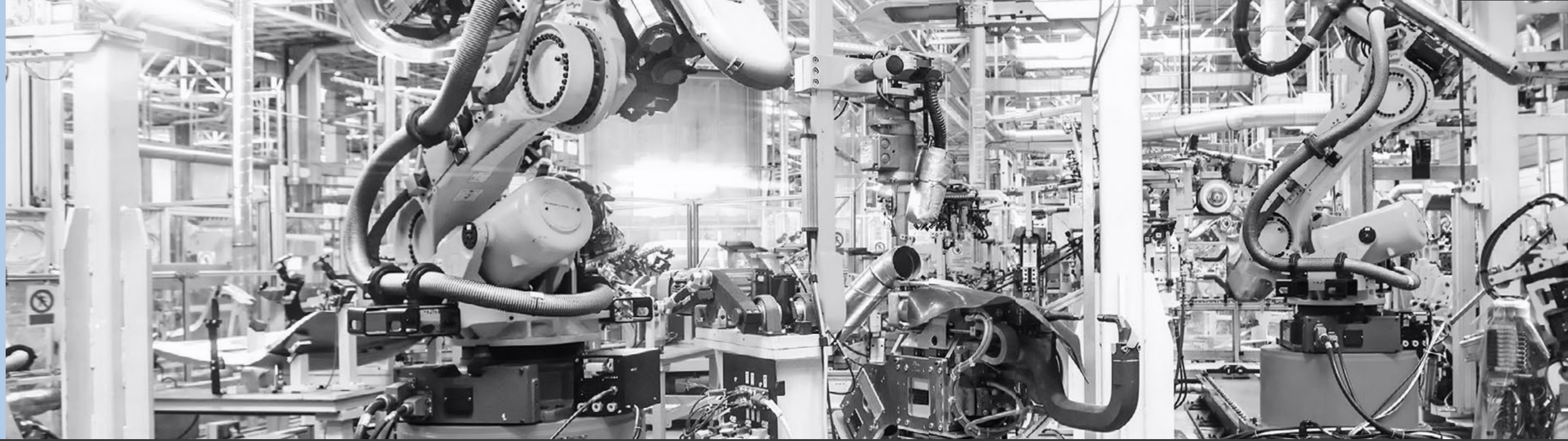

# Cable Bundling

Our cutting-edge products are designed and tested to withstand extreme conditions such as high heat, cold temperatures, abrasion, chemicals, and more. This ensures that your cables are well-protected and can continue to function at their optimal level. Our team of experts collaborates closely with clients, tailoring solutions to their unique needs. Our innovative cable bundling solutions not only protect against potential hazards but also organize and streamline cables, simplifying maintenance and installation. This allows for efficient use of space while reducing the risk of damage. Our mission is to ensure that your cables are protected against any potential hazards so you can focus on your primary goals and the journey toward success.

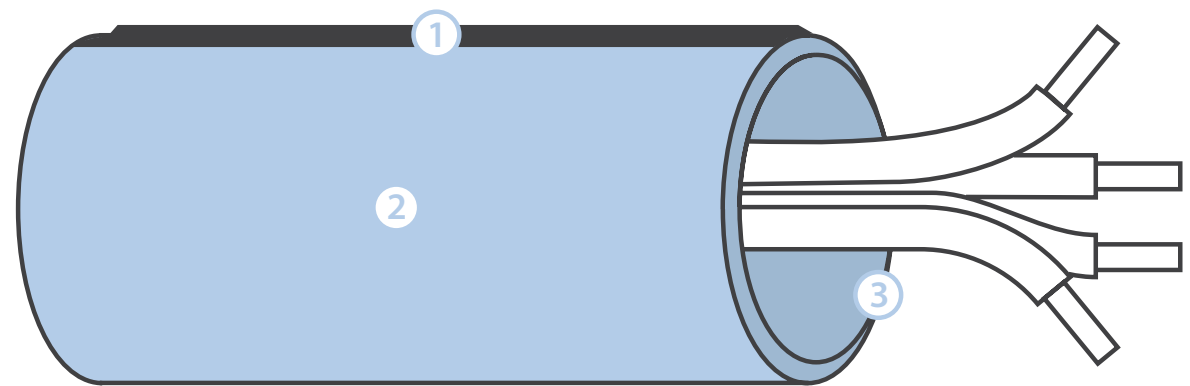

① Closure

② Jacketing

③ Shape

[Shop Standard Cable Bundling Products](#)



[Need something custom? Contact one of our engineers!](#)



**Zip-Wrap® (PVL)**

A lightweight, abrasion-resistant jacketing with a zipper offered in many color combinations for protective, color-coded cable bundling.



**Hook-It® (VNH)**

A military-grade, flame-retardant cable management solution with a Velcro-style hook-and-loop closure for quick re-entry.



**Z-Wrap® (63)**

Wrap-around cable bundling solution: military-grade, abrasion-resistant, fluid-resistant, flame-retardant, and adhesive closure for protection.



**Zip-On® (PFR)**

A wrap-around cable protection solution that is flexible, resistant to abrasion and fluids, and has a pressure track closure.



**Snap-Grip®**

A lightweight, PVC-coated cable bundling solution, available in various colors with nylon snaps for easy re-entry, offering protection and convenience.



**ZT-Tape®**

A high-quality fire-resistant, abrasion-resistant and chemical-resistant electrical tape made of a non-PVC polyurethane film for insulation of wiring.

## TOP SELLING PRODUCTS



# EMI Shielding

Explore Zippertubing's premium EMI shielding solutions, meticulously designed to protect your electronics from electromagnetic interference. Our diverse range includes conductive tapes, flexible wrap-around jackets, and more, providing robust protection for sensitive equipment across multiple industries. Zippertubing's commitment to quality and versatility ensures your EMI shielding needs are met with excellence. Trust us to keep your electronics performing at their best. Visit our website today to discover the perfect solution for your EMI shielding requirements.

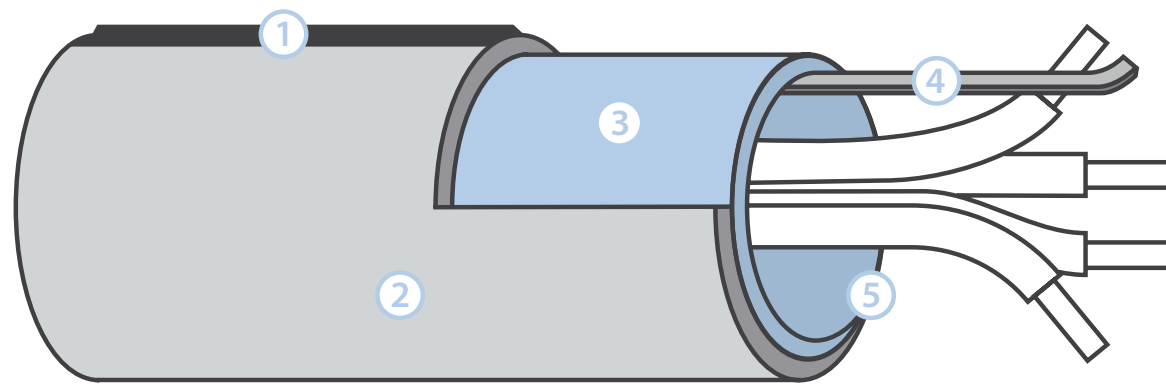

① Closure ② Jacketing ③ EMI Shield ④ Ground Braid ⑤ Shape



### Zipper-Mesh™

EMI-shielding solution made from either a two-ply or four-ply knitted shielding mesh—equipped with a zipper closure for quick and easy application.



### Hook-N-Shield® (VNH)

A wrap-around EMI shielding solution pairing a military-grade jacket with shielding mesh and a Velcro-style hook-and-loop closure.



### Zip-Mesh® (Al)

An EMI shielding tape that has a tinned copper mesh with an aluminum polyester tape and a self-adhesive closure.



### Z-Shield® (Al)

A wrap-around, EMI-shielding solution featuring a flame-retardant polyurethane jacket and high-performing shielding foil.



### Flex-Shield (HP)

A braided, expandable EMI, RFI and EMF shielding sleeve that is lightweight and flexible—an ideal solution for the aerospace industry.



### Z-3250-Tape

A lightweight EMI shielding tape that is flexible, durable and corrosion resistant for a variety of applications.

[Shop Standard EMI Shielding Products](#)



[Need something custom? Contact one of our engineers!](#)



## TOP SELLING PRODUCTS

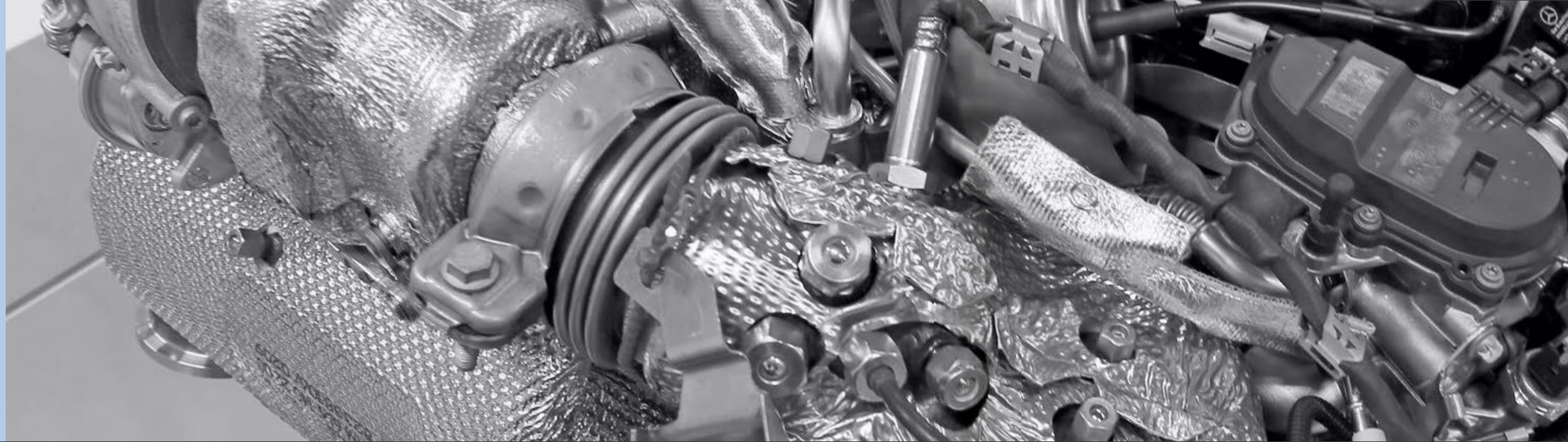

Discover top-quality heat shielding solutions at Zippertubing. Our collection offers unparalleled protection for cables, wires, and components from thermal degradation. Engineered with precision and durability, our products ensure high performance in extreme conditions. Explore our wide range of customizable solutions that safeguard your equipment and ensure reliable functionality in high temperatures.

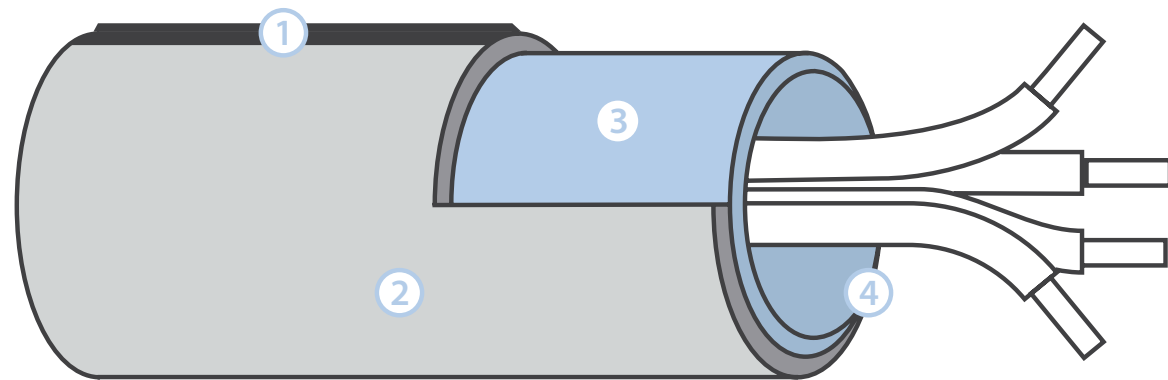

① Closure ② Jacketing ③ Optional Secondary Insulation ④ Shape

[Shop Standard Heat Shielding Products](#)

[Need something custom? Contact one of our engineers!](#)



**ZTT® (ALHTG)**  
A heat shielding sleeve that offers complete protection from temperatures up to 1,202°F and is equipped with a cloth leader for easy pull-through installation.

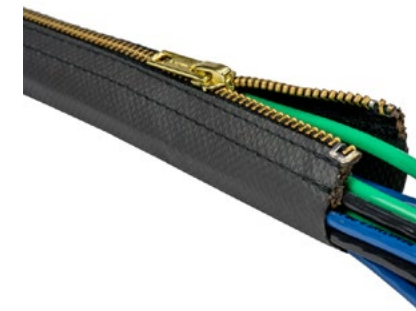

**Zip-Wrap® (RPH)**  
A flexible yet rugged solution that is equipped with a secure, heat-resistant brass zipper and durable sleeve to handle extremely high and low temperatures.



**Insuflect® (650)**  
Aluminized Fiberglass with Fiber Mat and Woven Silica Cloth Inner Jackets, Up to 1,202°F



**HeatReflect® (AFA)**  
A completely customizable heat shielding solution with adhesive backing – the shapes and sizes for applications are endless



**Snap-Grip® (SAM-1000)**  
A heat shield with silicone-coated fiberglass and stainless-steel snaps, protecting components from high temperatures.



**Zip-On® (FEP)**  
A wrap-around Teflon® solution pairing a clear, non-flammable, low-outgassing jacketing and pressure track for exceptional cable bundling and protection.

**TOP SELLING PRODUCTS**

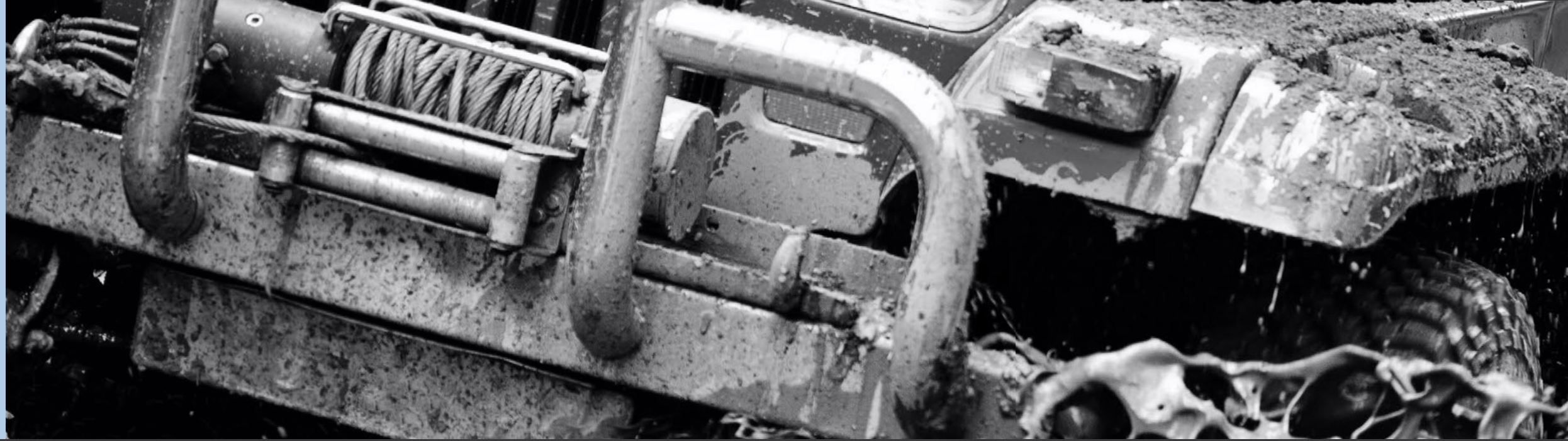

# Heat Shrink

Discover our premium selection of heat shrink products designed to meet a myriad of needs. Engineered with precision and innovation, each product offers unique benefits not found elsewhere. From durable, wrap-around, environmentally sealed shrink tubing to dual-wall EMI shielded tubing our solutions offer superior protection and durability. Whether you're tackling automotive wiring or aerospace applications our versatile range of shrink tubing products offer uncompromising quality. Explore our collection today and elevate your projects with reliable heat shrink solutions tailored to exceed expectations.

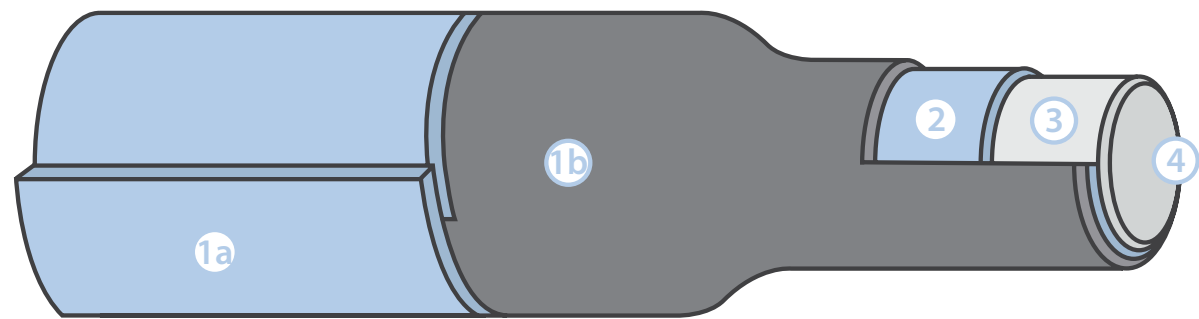

①a Wrap-Around Shrink Tubing OR ①b Pull-Through Shrink Tubing

② Optional Hot Melt Adhesive ③ Optional EMI Shielding ④ Shrink Ratio

[Shop Standard Heat Shrink Products](#)



[Need something custom? Contact one of our engineers!](#)



### PRT®

A wrap-around heat shrink made from MIL-SPEC tubing that repairs electrical systems and assembled components and is resistant to abrasion and chemicals.



### PRT® (ES)

A wrap-around, military-grade heat shrink paired with a high-temperature water blocking, hot-melt adhesive that protects against harsh environmental conditions.



### PRT® (Clear)

A clear, military-grade, wrap-around heat shrink ideal for applications that need a durable repair and the ability to see through to the wire labels.



### Shrink-N-Shield®

A heat-shrink tubing that provides exceptional shielding from EMI, RFI and EMF.



### Z-Block®

A hot-melt adhesive tape that blocks and seals wires from water, oils, greases, and most fluids and can handle temperatures up to 275°F (135°C).



### Shrink-N-Shield® (PTFE)

A flame-retardant, abrasion-resistant, and chemically inert heat shrink tubing with a 4:1 ratio, capable of withstanding temperatures up to 250°F.

## TOP SELLING PRODUCTS



**ZT** | zippertubing®



**zippertubing.com | 855.289.1874**

Copyright © 2022 The Zippertubing® Co., All Rights Reserved