

Comparative Impact Performances of Lightweight Gym Floors

Lloyd Cosstick¹, Evan Hong¹ and Tim Murray¹

¹Embelton Noise and Vibration, Melbourne VIC 3058, Australia

ABSTRACT

Gyms are a common source of complaints for adjacent tenancies due to vibration and impact related noise issues. In many cases it is impractical to install a concrete floating slab and therefore lightweight floor options are increasingly being considered for retrofitting. This paper presents test data results for noise and vibration levels of low and high density rubber installed directly onto a suspended slab, rubber mounts under plywood and damped spring mounts under plywood. A comparative test was also performed between plywood and compressed fibre cement on damped spring mounts. A 10kg kettlebell was dropped ten times from 620mm height for each system. A Svantek 958 Analyser was used to record noise and vibration levels for each impact. High density rubber achieved the lowest improvement of 9.1 dB while damped spring mounts under plywood achieved the highest reduction of 30.8 dB. Damped spring mounts also achieved the highest attenuation for vibration levels. Low and high density rubbers installed directly on the slab amplified vibration levels. The secondary study indicated that compressed fibre cement provided significantly improved results compared to an equivalent plywood system.

1. INTRODUCTION

Structurally isolated floors reduce noise and vibration transfer from various types of harmonic excitations and impacts. While heavyweight constructions are preferable for performance, lightweight isolated floors can be retrofitted, are cost effective and are much more easily removed for changes in tenancy. For this reason, they are commonly employed in gyms located in apartments, commercial buildings and hospitals. However, a lack of clarity exists around comparative performance in selection of lightweight floor build-ups due to the vast range of options for isolation layers.

It is commonly accepted that free weights, pin weight machines, treadmills and aerobic exercises are the typical sources of complaints from people occupying spaces adjacent to gyms due to annoyance from vibration and associated structure-borne noise. Treadmill and aerobic activities input low frequency excitation of less than 3.2Hz on the floor (Bachmann & Amman, 1987). The effects of these activities are largely dependent on the underlying structural concrete slab's modes of vibration. Computational analysis is required to express the effects of treadmill and aerobic activities which will not be covered in this paper. Pin weight machine isolation has been achieved in many cases by installing spring mounts directly underneath weight stacks, providing effective cushioning support and negating the need for an acoustic floor. As such, the performance of the lightweight floor types in this paper is measured by a single impact typical of free weight drops only.

This paper presents the acoustic and vibration testing method and results carried out on four commonly used floor types. A further study follows with a differing test method on the effect of using compressed fibre cement (CFC) compared to plywood as a separated floor layer. The aim of this paper is to provide a comparison of acoustic and vibrational performance between different lightweight gym floor systems. It should be noted that all materials except for low density rubber are Embelton products.

2. LIGHTWEIGHT GYM FLOORS

2.1 Test A Floor Systems

The floor systems were characterised by two types; rubber mat systems laid onto the slab and isolated floating floor systems. The four test floor systems differing in cost, materials used and finished height are as follows, with floor systems presented in order of expected performance (lowest to highest).

2.1.1 High density rubber tile top surface finish

- 15mm high density rubber top surface (approximately 800 kg/m³) 1.2 x 1.0 metre tiles installed directly onto 150mm concrete slab.
- 150mm ceiling cavity with 10mm plasterboard rigidly fixed.

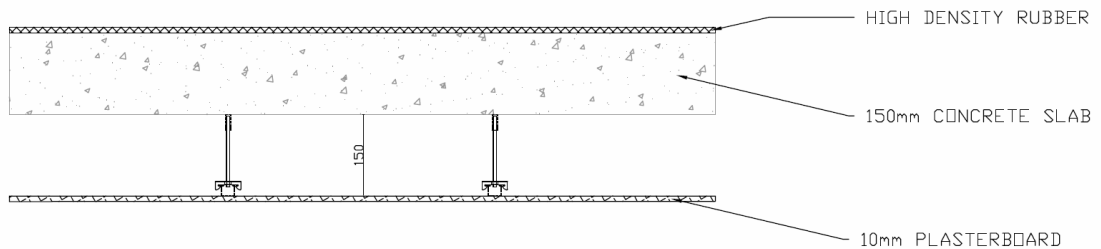

Figure 1: High density rubber floor build-up

2.1.2 Low density rubber underlay tile with top surface finish

- 25mm, 50mm, 75mm and 100mm low density rubber underlay tiles (approximately 600 kg/m³) 1.0 x 1.0 metre tiles installed directly onto 150mm concrete slab.
- 15mm high density rubber top surface finish (as in 2.1.1).
- 150mm ceiling cavity with 10mm plasterboard rigidly fixed.

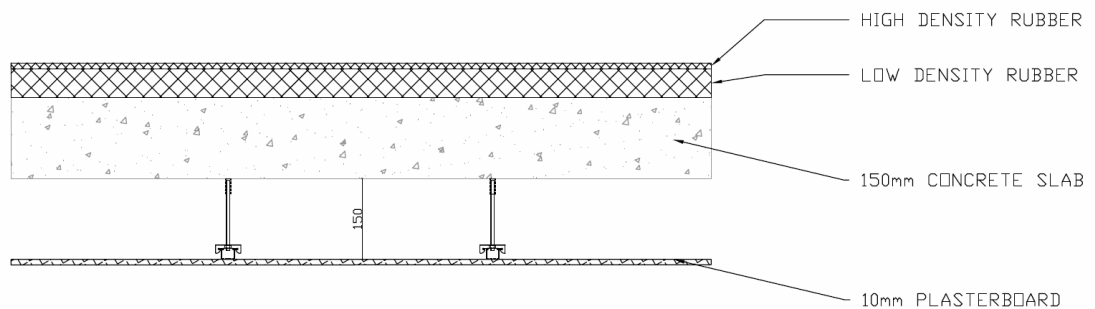

Figure 2: Low density rubber with top surface rubber build-up

2.1.3 Rubber mounts under plywood with top surface finish

- Embelton NRD3 rubber mounts installed onto 150mm concrete slab at 600 x 600mm spacing.
- 2 layers of adhered 2400 x 2400 x 14mm plywood installed over rubber mounts.
- 15mm high density rubber top surface finish (as in 2.1.1).
- Cavity filled with 50mm 32 kg/m³ polyester insulation.
- 115mm overall free height.
- 150mm ceiling cavity with 10mm plasterboard rigidly fixed.

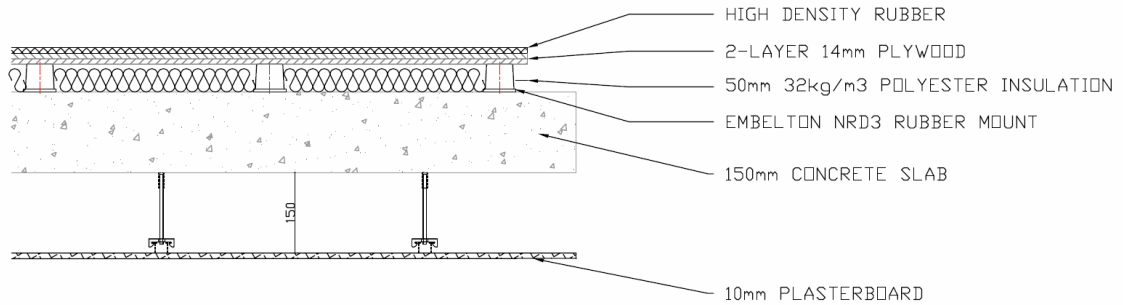

Figure 3: Rubber mounts with 2-layer 14mm plywood and top surface rubber build-up

2.1.4 Damped spring mounts under plywood with top surface finish

- Embelton 25mm deflection damped spring installed onto 150mm concrete slab at 600 x 600mm spacing.
- 2 layers of adhered 2400 x 2400 x 14mm plywood installed over damped spring mounts.
- 15mm high density rubber top surface finish (as in 2.1.1).
- Cavity filled with 50mm 32 kg/m³ polyester insulation.
- 137mm overall free height.
- 150mm ceiling cavity with 10mm plasterboard rigidly fixed.

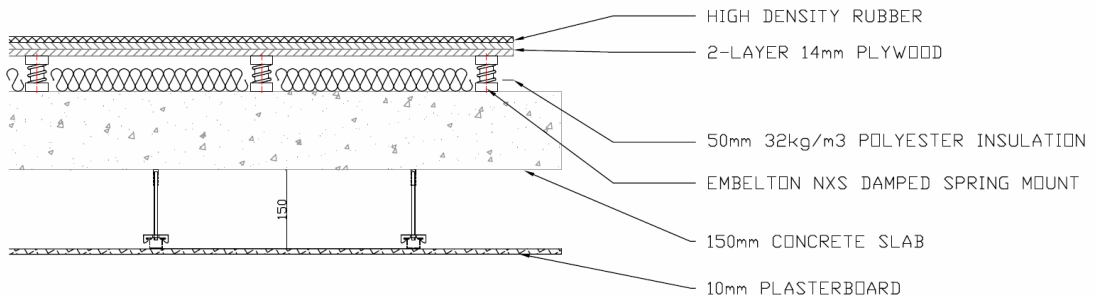

Figure 4: Damped springs with 2-layer 14mm plywood and top surface rubber build-up

2.2 Test B Floor Systems

A further study comparing the performance of plywood to CFC used the following systems:

2.2.1 Damped spring mounts under plywood with top surface finish

- Embelton 25mm deflection damped spring mounts installed onto 150mm concrete slab at 600 x 600mm spacing.
- Steel support channels installed over the top of damped spring mounts.
- 2 layers of 1200 x 1200 x 18mm plywood clamped to channels.
- 15mm high density rubber top surface finish (as in 2.1.1).
- Cavity filled with 50mm 32 kg/m³ polyester insulation.
- 147mm overall free height.
- No ceiling installed.

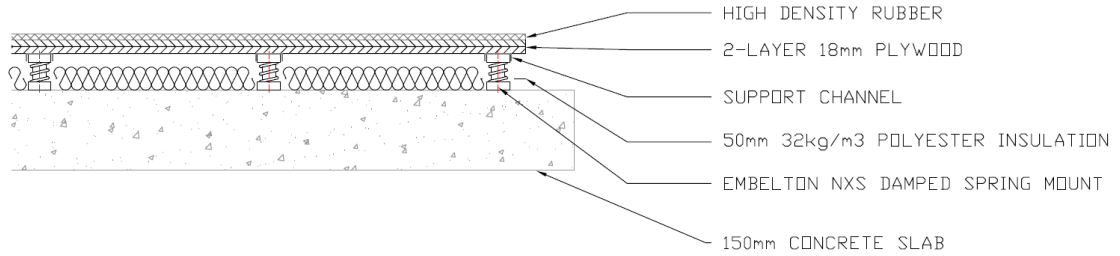

Figure 5: Damped springs with 2-layer 18mm plywood and top surface rubber build-up

2.2.2 Damped spring mounts under compressed fibre cement with top surface finish

- Embelton 25mm deflection damped spring installed onto 150mm concrete slab at 600 x 600mm spacing.
- Steel support channels installed over the top of damped spring mounts.
- 2 layers of 1200 x 1200 x 18mm CFC clamped to channels.
- 15mm high density rubber top surface finish (as in 2.1.1).
- Cavity filled with 50mm 32 kg/m³ polyester insulation.
- 147mm overall free height.
- No ceiling installed.

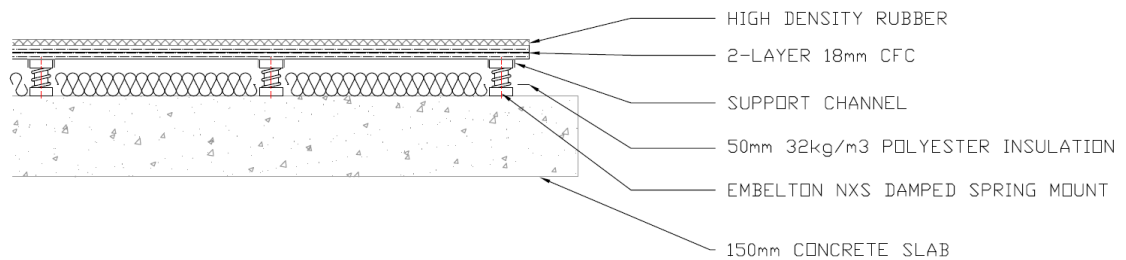

Figure 6: Damped springs with 2-layer 18mm CFC with top surface rubber build-up

The floor area of floor systems 2.2.1 and 2.2.2 used were smaller than those of 2.1.3 and 2.1.4 and will therefore only be compared separately from Test A.

3. EQUIPMENT

3.1 Test Facility

Testing was conducted at Embelton’s onsite facility comprising of an isolated concrete slab and receiving room of approximately 80m³ volume. Floor samples were built onto the 10.8 m², 150mm thick 32MPa 20 Hz concrete slab. The slab is isolated by a rubber layer from the surrounding concrete structure to minimise the influence of wall flanking transmissions.

3.2 10kg Kettlebell

In the absence of International or Australian standards for heavy rigid impact testing, a 10kg kettlebell dropped from 620mm height would be used. It was expected that a kettlebell would deliver more repeatable localised impact as opposed to a dumbbell. Due to occupational health and safety concerns with repeated weight drops, heavier test weights were not used.

3.3 Svantek 958 Analyser

A calibrated Svantek 958 Analyser was used with a microphone attachment for acoustic testing in $1/3^{\text{rd}}$ octave bands. For vibration tests, a uniaxial accelerometer attachment was fixed to the top side of the concrete slab with the analyser acting as the transducer. Measurements were taken in $1/3^{\text{rd}}$ octave bands and weighted as presented in results.

4. METHODOLOGY

4.1 Test A

A ceiling system comprising of 10mm plasterboard with 150mm air cavity was installed underneath the isolated concrete slab in the receiving room. A 10kg kettlebell was dropped 10 times for each test floor at the centre of the isolated floor system. Results were averaged to minimise measurement errors and variability. L_{max} was measured from the centre of the receiving room over 2 seconds between 20 Hz to 20 kHz using the Svantek 958 Analyser's trigger function following weight drop. RMS acceleration levels on the concrete slab were measured over a 2 second interval for 10 additional weight drops following acoustic testing on each test floor.

4.2 Test B

No ceiling was installed for the further testing of CFC and plywood on damped spring mounts. This was expected to influence acoustic results substantially in comparison to Test A. L_{max} was measured between 0.8 Hz and 20 kHz using the Svantek 958 Analyser's start delay function and 60 second interval period over 10 cycles. A single 10kg kettlebell drop was registered for each cycle. The L_{max} dB(A) values were used to compare the performance between Test B floor setups. The RMS acceleration levels were recorded over a 10 second interval for 10 additional weight drops.

5. RESULTS

5.1 Acoustic Test A Results

Table 1: Single L_{max} dB(A) values for Test A floor types

Floor System	L_{max} dB(A)
Damped Springs	63.2
75mm Low Density Rubber	64.2
100mm Low Density Rubber	65.2
Rubber Mounts	66.7
50mm Low Density Rubber	70.4
25mm Low Density Rubber	72.5
15mm High Density Rubber	84.9
Bare Concrete Slab	94.0

All floor types provided significant improvement to the bare concrete slab at high frequencies (Figure 7). Damped springs provided the greatest acoustic performance with a 30.8 dB reduction (Table 1) while 15mm high density rubber provided the least improvement with 9 dB reduction. A noticeable peak was observed for all Test A floor types at 63 Hz. Damped springs consistently outperformed all other

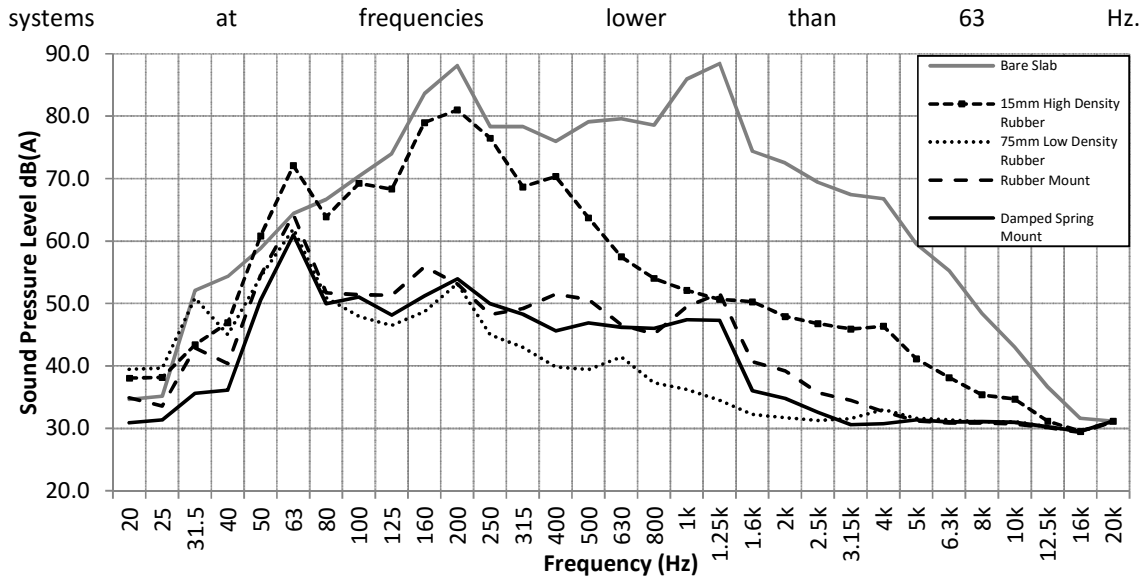

Figure 7: 1/3rd Octave L_{max} for Test A floor systems

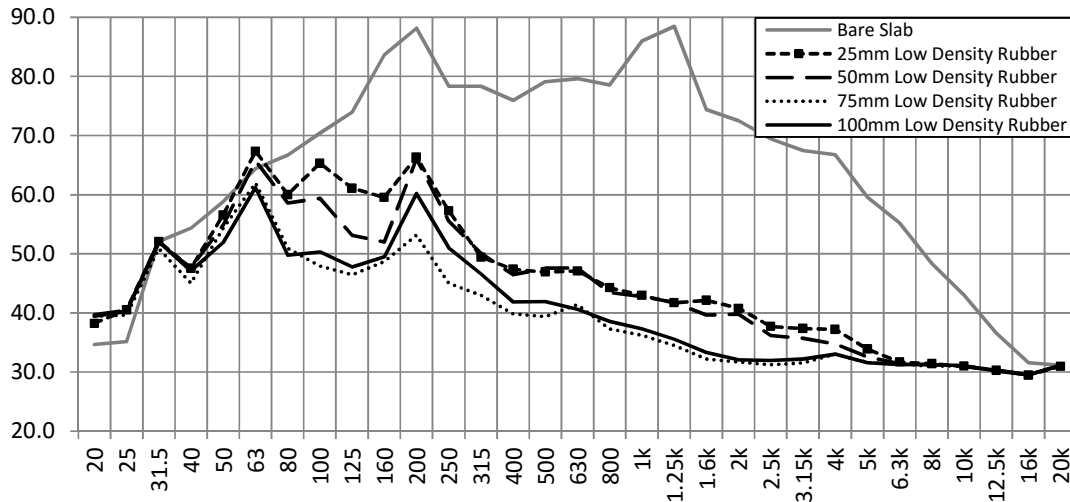

Figure 8: 1/3rd Octave L_{max} for Test A low density rubber systems

4.2 Vibration Test A Results

Table 2: BS 6472:2008 Weighted single value RMS acceleration for Test A floor types

Floor System	Weighted RMS (mm/s^2)
Damped Springs	22.3
Rubber Mounts	30.6
Bare Concrete Slab	56.5
15mm High Density Rubber	67.4
75mm Low Density Rubber	67.5
100mm Low Density Rubber	67.6
50mm Low Density Rubber	71.5
25mm Low Density Rubber	72.0

The rubber mounts and damped springs recorded improved vibration levels from the weight drops over the bare slab between 1-80 Hz (Table 2). The rubber mat systems amplified the vibration of

the concrete slab. Damped springs provided the greatest attenuation with a 60.5% reduction. The 25mm low density rubber was the worst performing, marking a 27.4% increase compared to bare concrete slab. A noticeable peak was present for all test floors at 20 Hz, which indicates the slab fundamental frequency.

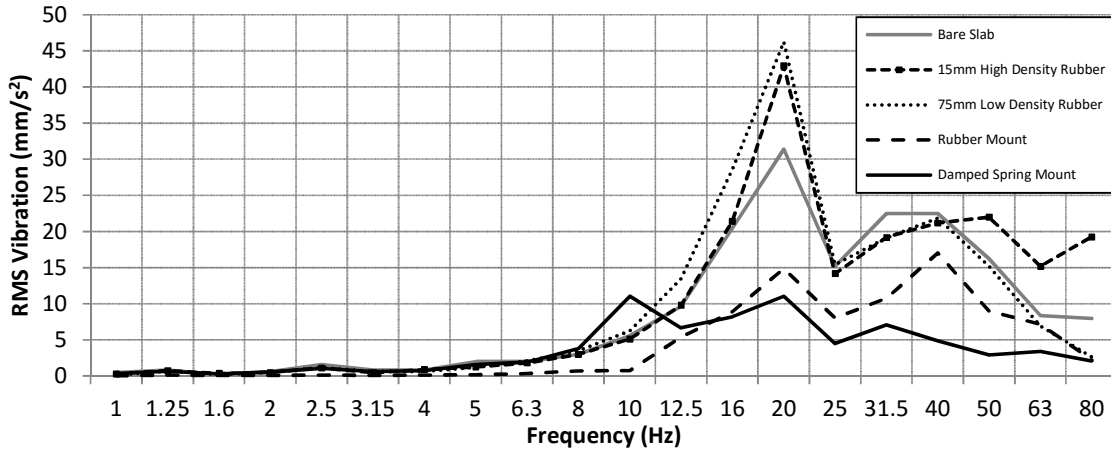

Figure 9: 1/3 Octave weighted RMS values for Test A floor systems

4.3 Acoustic Test B Results

Table 3: Single A-weighted L_{max} values for Test B floor types

Floor System	L_{max} dB(A)
Plywood on Damped Springs	71.3
Compressed Fibre Cement on Damped Springs	64.8

A 6.5 dB improvement in performance was observed with the CFC systems over the plywood system (Table 3). The CFC reached a maximum of 60.4 dB(A) at 50 Hz in comparison to plywood’s 70.3 dB(A) at 250 Hz. From 80 Hz onwards, it is clear that the CFC on damped spring mounts provides superior noise reduction with respect to the plywood.

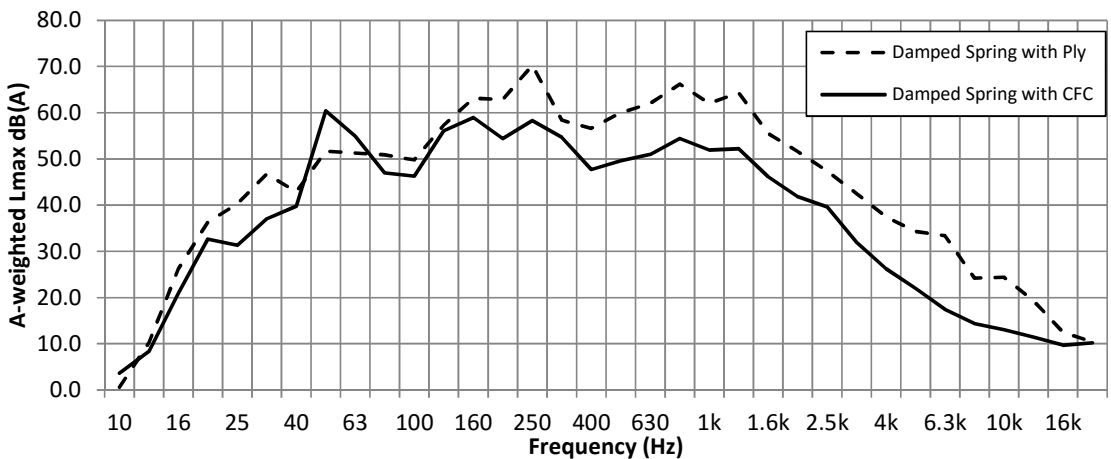

Figure 10: 1/3 Octave L_{max} for Test B floor systems

4.4 Vibration Test B Results

Table 4: BS 6472:2008 Weighted single value RMS acceleration for Test B floor types

Floor System	Weighted RMS (mm/s ²)
Plywood on Damped Springs	20.4
Compressed Fibre Cement on Damped Springs	13.9

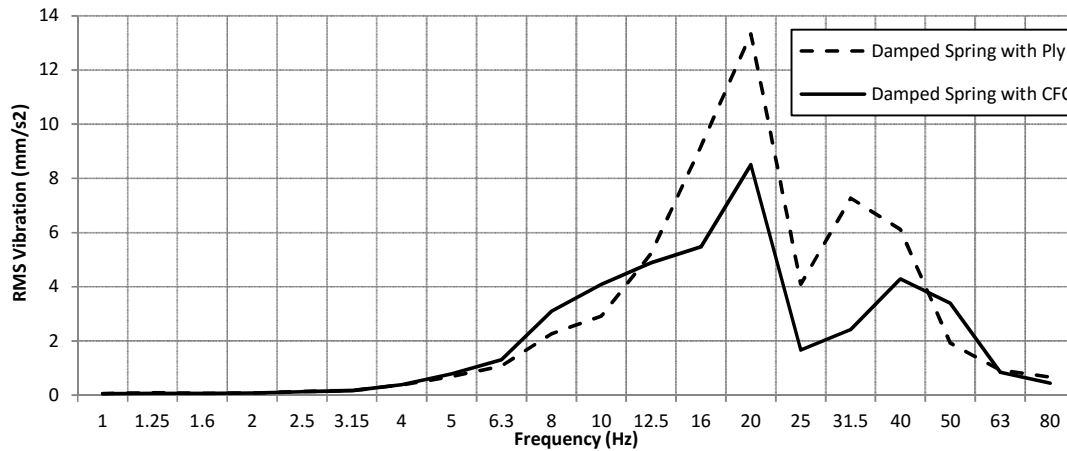

Figure 11: 1/3 Octave weighted RMS values for Test B floor systems

The CFC also outperformed the plywood in vibration testing. The single value weighted RMS acceleration for the plywood was 20.4mm/s² compared to 13.9mm/s² of the CFC, a reduction of 32%.

5. ANALYSIS

5.1 Test A Discussion

The surface area of plywood was approximately 4 times larger than the rubber mat systems. This was not expected to have affected the results due to plywood’s rigidity requiring a large area to account for realistic load spreading from impact, and the flexibility of rubber mats constraining the spread of the impact to a smaller area.

The rubber mat systems provided minimal acoustic improvements at low frequencies. The 15mm high density rubber resulted in reductions of up to 25 dB at frequencies greater than 1.25 kHz. The 75mm low density rubber underlay performed best of all low density rubber thicknesses with significant attenuation for frequencies higher than 80 Hz. Reductions greater than 50 dB were measured above 1.25 kHz. Vibration levels between 1-80 Hz in the concrete slab were amplified by 19.5% when using rubber matting.

Rubber mounts provided improved acoustic isolation at lower frequencies than rubber matting, although its overall single A-weighted value was higher than 75mm low density rubber system by 2.5 dB. It was expected that the use of rubber mounts would outperform the low density rubber due to discrete transmission points, and an overall lower stiffness per square metre. However, the low density rubber provided superior attenuation at frequencies higher than 80 Hz. This may be due to the lack of any semi-rigid component with high resonant frequencies within the system such as plywood. Within the source room the low density rubber system deadened the noise from impact considerably more than the plywood systems. However, the rubber mounts reduced the vibration levels measured for the 20 Hz concrete slab by a substantial 45.8%.

The damped spring system achieved the highest attenuation in both acoustic and vibration testing with 30.8 dB noise reduction from the bare slab and 60.5% lower weighted RMS acceleration. The acoustic attenuation was consistently high for the damped springs across all frequency bands.

The amplification in vibration at low frequencies compared to bare concrete results is likely due to lower resonant frequencies of the rubber being excited. Distinct pairs of data were observed between the low density rubber samples (Figure 8). The 25mm and 50mm systems produced similar results in acoustic and vibration testing, while the 75mm and 100mm systems also behaved similarly. It was expected that there would be an incremental improvement with increasing thickness. The reasons for two distinct pairs of data are not entirely clear, although it is suggested that the 25mm and 50mm systems may have formed an essentially rigid connection to the concrete slab due to being overly compressed by the impact. With the 75mm and 100mm systems, a greater load spreading across the floor area due to the additional thickness may have prevented this.

Further testing can be conducted to investigate the performance of damped springs with plywood and low density rubber underlay and a high density rubber top surface. This system would be expected to improve comfort, reduce vibration levels otherwise present for low density rubber, while maintaining the airborne acoustic benefits.

5.2 Test B Discussion

The CFC on damped springs resulted in lower L_{max} noise levels and vibration levels than the plywood. This was expected due to the higher density of CFC. The extra weight added onto the damped springs increased static deflection, thereby lowering the natural frequency. Further, the CFC's greater inertia results in a lower amplitude of displacement following impact. Airborne noise performance also benefits from additional mass at frequencies well above resonance as the effectiveness of a wall or floor in blocking sound is largely mass dependent.

From Figure 11 it can be seen that the vibration was measured higher for the CFC at 50 Hz which is directly related to the point where the A-weighted L_{max} was greater for CFC than plywood. A resonant frequency of CFC may have been a contributing factor.

6. CONCLUSIONS

Comparative performance of some common lightweight gym flooring options has been presented in terms of structure borne noise levels measured in an adjacent space and vibration of the underlying isolated 20 Hz concrete slab following a discrete impact. Not discussed throughout this paper are some of the practical and subjective considerations such as cost, ease of installation and comfort.

The damped spring system in Test A was the best performing system in terms of both slab vibration and structure borne noise measured in the receiving room, with 60.5% and 30.8 dB reductions respectively. Although 75mm low density rubber performed comparably to damped springs in the acoustic testing with only 1 dB difference, it amplified weighted vibration levels compared to the bare concrete slab. The use of rubber mounts instead of damped springs generated higher noise levels than both 75mm low density rubber and damped springs but showed significant improvement over the low density rubber in weighted vibration results. By itself, the high density rubber tile resulted in the least noise reduction from the bare slab test. Further testing of low density rubber on top of the plywood damped spring system would likely yield a higher benchmark in performance. However, test results proved that to gain vibration improvement between 1-80 Hz a separated floor such as plywood or CFC on rubber or damped spring mounts would be required as a minimum as no combination of rubber matting by itself provided attenuation.

Test B results demonstrated that the use of CFC as a structural flooring material provides a measurable improvement to plywood in both vibration and noise isolation when used with a 20 Hz

concrete slab. Also due to its mass, the CFC could be considered an option when the natural frequency of the floating floor isolators are required to be engineered to a specific range.

REFERENCES

Bachmann H, & Ammann W 1987 'Vibrations in Structures Induced by Man and Machines', *International Association for Bridge and Structural Engineering (IABSE)*; Structural Engineering Document 3e, ch. 2

British Standards. Guide to evaluation of human exposure to vibration in buildings. Vibration sources other than blasting. BS 6472-1:2008. Appendix B BS 642 weightings