

Seismic Spring Mount Type CWDM/CDM

50mm Static Deflection

APPLICATION

Where equipment requires the use of a spring type mount for a high degree of isolation under normal operating conditions, but with the facility to restrain the equipment from excessive motion in any direction due to displacement inputs imparted by the foundation through earthquake activity.

DESCRIPTION

An integrated, stand-alone six direction restrained spring mount with cup located spring and internal adjustment. w/CDM mounts are rated to the static force restraint requirements of:

- AS 1170.4 for application up to maximum equipment loads in all Australian seismic zones
- NZS 4219 for application with reduced equipment load range in New Zealand

FEATURES

- Heavy duty stable steel spring
- Acoustically isolating location cup
- Single fully adjustable central vertical restraint and leveling bolt
- Alternative equipment mounting positions
- Restraint assembly can be retro-fitted (see Installation)
- Replaceable shock absorbing rubber snubbers

RESTRAINT CAPACITY

Restraint capacity is given as a maximum static force. The following can be applied simultaneously in one lateral direction and vertically up or down:

Type	Vertical	Lateral
CWDM	6.0kN	3.0kN
CDM	11.0kN	5.5kN

At maximum restraint loads, the displacement from normal operating position is approximately 10mm.

CONSTRUCTION

Hot dipped galvanised steel housing, oil-resistant high-frequency spring base isolation cup. All other components, including spring, are zinc plated.

DESIGN

CWDM/CDM Mounts are designed with spring horizontal to vertical stiffness ratios between 0.9 and 1.0 at rated loads; ratio of spring diameter to loaded height minimum 0.8; and a rated maximum static operating deflection 2/3 deflection to solid.

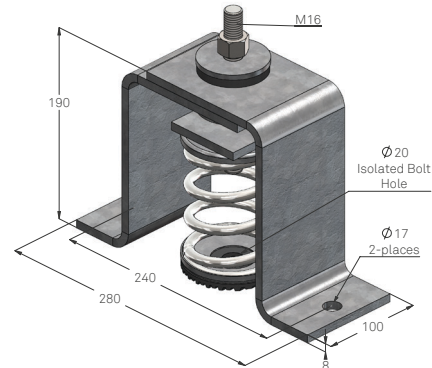

CWDM DIMENSIONS

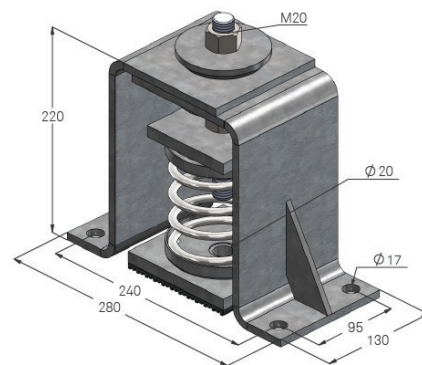

CDM DIMENSIONS

Type	Max Load kg	Static Deflection mm	Spring Constant kg/mm	Spring Colours	
				Stripe 1	Stripe 2
CWDM-33	50	50	1.0	White	-
CWDM-34	75	50	1.5	Violet	-
CWDM-35	110	50	2.2	Yellow	-
CWDM-36	150	50	3.0	Brown	-
CWDM-37	200	50	4.0	Orange	-
CWDM-38	250	50	5.0	Orange	Black
CWDM-39	350	40	8.8	Orange	Green
				Outer	Inner
CDM-50	65	50	1.3	Blue	-
CDM-51	125	50	2.5	Black	-
CDM-510	195	50	3.9	Black	Blue
CDM-52	225	50	4.5	Red	-
CDM-520	295	50	5.9	Red	Blue
CDM-521	350	50	7.0	Red	Black
CDM-53	450	50	9.0	Green	-
CDM-530	520	50	10.4	Green	Blue
CDM-531	575	50	11.5	Green	Black
CDM-532	700	50	14.0	Green	Red
CDM-55	650	50	13.0	Grey	-
CDM-551	775	50	15.5	Grey	Black
CDM-552	900	50	18.0	Grey	Red
CDM-553	1,000	50	20.0	Grey	Green
CDM-593	1,115	45	24.8	Orange	Green

ACOUSTICAL ISOLATION

Although steel spring mounts provide particularly effective isolation of mechanical vibration, the spring itself, depending on its physical geometry, may transmit certain audible level frequencies.

To minimise these audible level transmissions, all mounts are fitted with a resilient rubber base cup. For type CWDM/CDM mounts, the standard cup has a theoretical effectiveness of over 95%-98% in isolating such transmissions.

MOUNT SELECTION

When selecting mounts, it is recommended that a safety factor of 10-20% is applied to the calculated mass of equipment to avoid overloading of any mount. If maximum rated deflections are required, then equipment should be weighed and an accurate assessment of point loads made.

For equipment using more than four mounts, endeavour to distribute them so that each mount has equal loading. If this cannot be done, mount selection must be made on the basis of matching static deflections as closely as possible.

RESTRAINT SYSTEM

These mounts incorporate replaceable resilient rubber snubbers for both vertical and lateral restraint. Vertical restraints have a normal design clearance of 5mm (gaps X and Y) in both directions and are adjustable ± 3 mm in conjunction with level adjustments. Lateral restraints have a fixed clearance of nominal 5mm.

INSTALLATION

1. LEVELING

- Check mount positions on foundation are all level to within 2mm. If not then shim low mounts (shim can be inserted between top steel washer and equipment).

2. HORIZONTAL ALIGNMENT

- The geometric centre of the housing hold down bolts must be aligned ± 1 mm with respect to the central restraining bolt i.e. the attachment point to the equipment, on all mounts.

3. BOLTING DOWN

- Foundation: Place housings in position and drill through housing base holes for fastening.
- The CWDM/CDM mounts are designed to take M16 fastenings.
- Housing fastenings should be torqued to the maximum value recommended by the fastener manufacturer.
- Equipment: A clearance hole for the central restraint bolt must be provided for the equipment base. The base must be designed to withstand maximum restraint forces generated.

4. PLACING EQUIPMENT

- Locate (or fasten down) the spring base plate.
- Assemble the rest of the mount with restraint nut removed.
- Place equipment on mounts. If mounting in position 2, equipment load maybe temporarily taken on the top of the housing via the rubber insert.
- Under no load, the housing bottom is above the foundation level. As the equipment load is applied, the housing drops to the foundation.

5. ADJUSTMENT AND LOCKING

- Fit the restraint nut but leave loose.
- Load the spring by winding the adjusting nut anticlockwise until the equipment is floating on the springs. Hold the compression plate stationary while winding.
- Check for level and adjust if necessary.
- Lift further until gap $X=5\text{mm} \pm 2\text{mm}$ on all mounts.
- Tighten the restraint nut hard against the equipment.

TECHNICAL ASSISTANCE

All Embelton offices can provide detailed technical assistance on the use of this product in specific applications.

CONDITIONS OF SALE

These products are sold subject to the published Embelton General Conditions of Sale, copies of which maybe inspected on request.

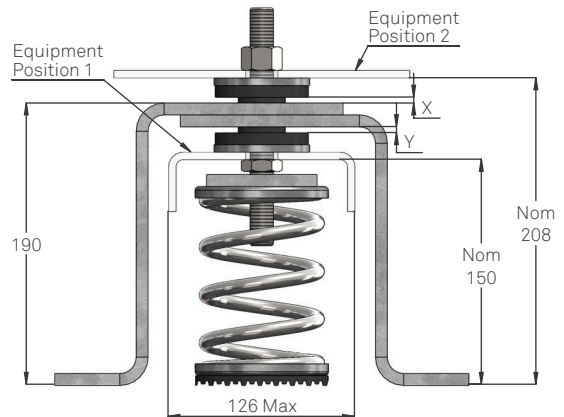

CWDM INSTALLATION

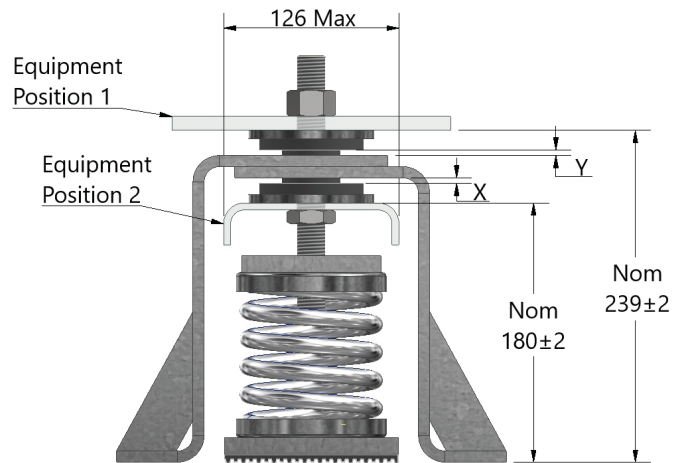

CDM INSTALLATION

SPECIFICATION

Spring mounts shall permit freedom of equipment motion at normal operating conditions, but restrain the equipment from excessive motion when subjected to foundation displacement in any direction. A single central vertical restraint bolt shall be used, which also locks the equipment to the mount. Springs shall be free standing and laterally stable with an acoustically isolating base cup. They shall have a minimum additional travel of 50% rated deflection to solid and a diameter not less than 0.8 of loaded height; they shall be type CWDM/CDM as supplied by Embelton.

THIS PAGE IS INTENTIONALLY LEFT BLANK