

Ablaze Mirrors

Mirror Cabinet Range

Installation Guide

Please read these instructions carefully and in full before installation.



Prior to Installation

- Please remove the mirror from the packaging and check for any damage. If there is any damage do not install the product and arrange for a replacement product.
- Mirror glass is very easily damaged. Please leave the door in the outer protective foam edging until this is required to avoid damaging the mirror.
- It is recommended to have two people present for installation.
- Ensure the wall is flat without raised parts to avoid issues with installation.
- Ensure sufficient supporting beams are fitted between the studs to give a solid wall backing for the cabinet to attach to.
- Only two of the 4 inside hanger plates will be used. This depends on the side the hinges are required (round and pill).

Note: It is the responsibility of the installer to make any adjustments to the door after installation if required. Movement in transportation and installation which causes doors to become unaligned must be corrected at install and are not covered as a warranty issue.

Tools & Parts Required for Installation

- Drill
- Phillips Head Screw Driver
- Suitable wall fixings dependant on wall type and mounting method
- Tape Measure
- 2x Wall Hangers (provided)
- Level

Cabinet Installation Overview

1. Locate support beams behind where the cabinet is to be mounted. Mark these locations.
2. Mount the metal plates to the wall using suitably rated wall plugs and screws. The piece of the mount with holes should be hard against the wall with the top tongue positioned away from the wall so the hanger on the cabinet can clip over this.
Note: the hangers will need to be set in 16mm from side and top of the overall cabinet size to allow them to sit in the recessed portion of the cabinet back.
3. Loosen the bottom and front screws (not the 2 side ones) in the hanger plates inside the cabinet to loosen the hanger. Once both top hangers are hanging out the back of the cabinet, mount the cabinet onto the two plates on the wall.
4. Tighten the bottom and front screws inside the cabinet to secure the cabinet against the wall. You may need someone to assist you with holding the cabinet in position whilst adjusting the screws.
5. Insert the adjustable shelf supports into the holes in the desired positions and insert the shelves.
6. Clip the door onto the hinges and adjust the hinges until the door is aligned. Referring to the third diagram below, insert the hinge into position A followed by position B until there is a click to lock the hinge in place.
7. It is the responsibility of the installer to make any adjustments to doors after installation. Refer to the door hinge alignment details opposite.

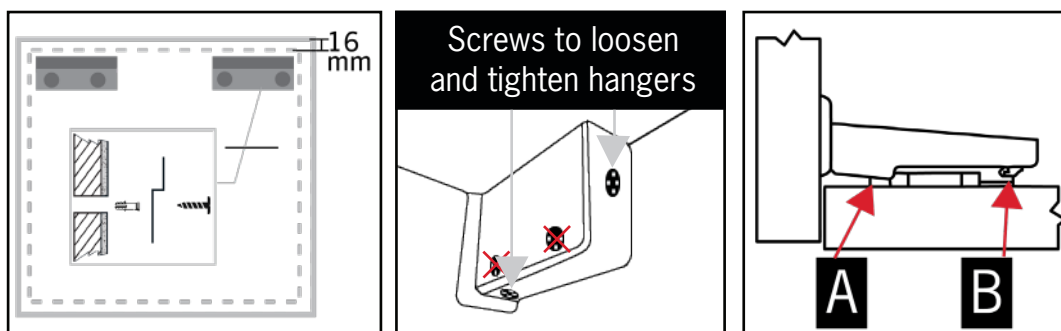

Optional: Recessing a mirror cabinet Arch & Pill Only, not compatible with Round

1. Cut or frame a hole 4mm bigger than the overall cabinet carcass in the wall. If the hole will be tiled or sheeted, please allow additional space accordingly. Ensure bottom and side of the cabinet have sufficient nogging to allow screwing through the carcass into the noggin.
2. Insert the cabinet into hole. Ensure the cabinet protrudes by a minimum of 40mm from the wall including tiles to allow the door to fully open.
3. Screw through the sides and bottom of the cabinet into the noggins previously installed.
4. Insert the adjustable shelf supports into the holes in the desired positions and insert the shelves.
5. Clip the door onto the hinges and adjust the hinges until the door is aligned. It is the responsibility of the installer to make any adjustments to doors after installation. Refer to the door hinge alignment details below.

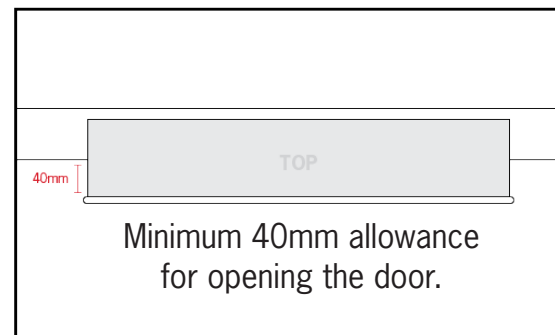
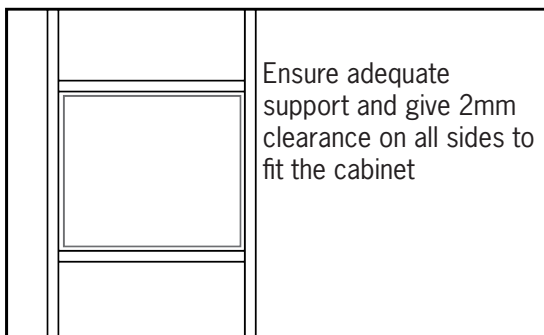

Door Hinge Alignment

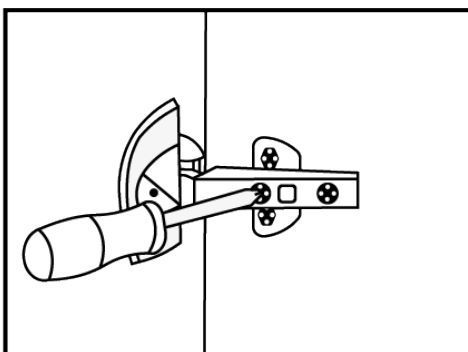

Side Adjustment

Use front screw to move door to the left or right, or to level each door.

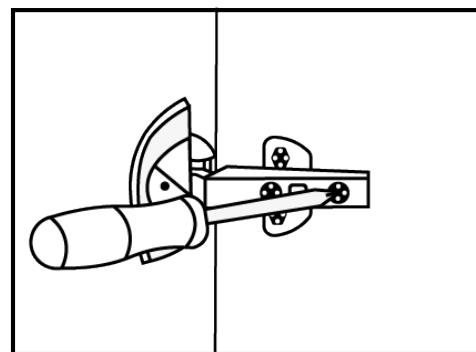

Depth Adjustment

Use back screw to move door inward or outward from carcass.

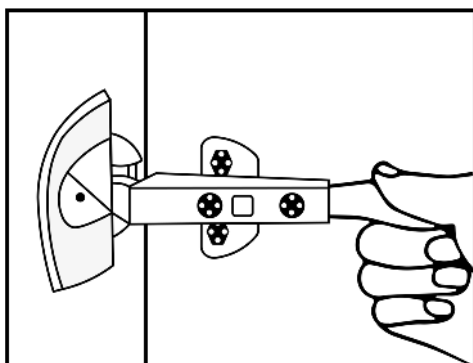

Removing and Installing Doors

To Remove Doors:

Apply finger pressure to clip at back of hinge and pull forward to release.

To Install Doors:

Align door hinge with mount on carcass, press back into place and listen for a 'click' to lock the hinge in place. You may need to apply a little force to lock the hinge in place.

Care and Maintenance

For best results clean mirror with methylated spirits and water at a rate of 30% methylated spirits to 70% water. Do not use Windex or similar cleaning products. Avoid getting water on the sides or back of the mirror as damage to the silver backing can occur. In coastal areas it is recommended to wipe around the edge of the mirror regularly to avoid salt build up that can cause silver creep.

Warranty Information

Thermogroup covers all its products with a satisfaction guarantee. In addition, Thermogroup will supply a replacement product where a fault is shown to be caused by manufacture, materials or workmanship providing the goods have been installed correctly and according to installation instructions. This guarantee does not include removal, freight or installation costs.

Our goods come with guarantees that cannot be excluded under the Australian Consumer Law. You are entitled to a replacement or refund for a major failure and compensation for any other reasonably foreseeable loss or damage. You are also entitled to have the goods repaired or replaced if the goods fail to be of acceptable quality and the failure does not amount to a major failure.

The Ablaze Mirror Cabinet Range have a 2 year warranty. To claim the warranty, repair or service the customer must provide purchase invoice/receipt.

If the product develops a fault within the warranty period due to normal wear and tear, Thermogroup at its discretion will recognise whether it's a faulty product or not. If it is impossible or not economical for the manufacturer to repair the product, the manufacturer will replace the faulty product with a new unit of the same model or if there is no stock available of the same model as the product, the manufacturer will replace the product with a new unit of a similar size. No responsibility can be taken for altered dimensions and lining up of existing holes.

The repair/replacement service offered within the warranty period only covers the faults and problems as developed from the manufacturer's errors. If the product fails whilst under warranty, the warranty only covers the replacement of the goods. Any damage caused by improper use or carelessness or incorrect wiring is not covered. Thermogroup is not responsible for any monetary loss or injuries caused by improper use of this product.



Contact Us

Phone: 1300 368 631 | Technical Helpline: 1300 989 464
sales@thermogroup.com.au | www.thermogroup.com.au