

PARTS LIST

2022.09.27

www.nilfisk-cfm.com



TABLE OF CONTENTS

L1 - 01 - FRAME.....	1
L1 - 02 - CONTAINER UNIT.....	3
L1 - 03 - SHAKER UNIT.....	5
L1 - 04 - FILTER GROUP.....	7
L1 - 05 - SUCTION UNIT.....	9
OPTIONALS.....	11

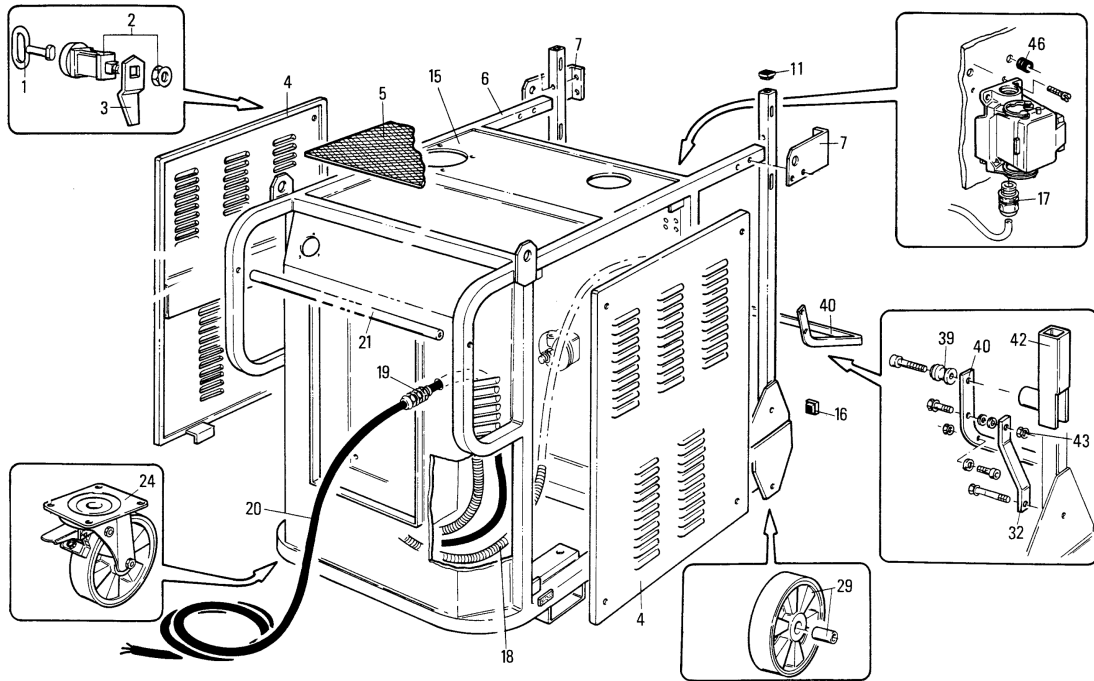

UNISTUDIO - Modena

No.	Part No.	Qty.	Description	Part Note
1	Z8 40245	1	KEY X LOCK	
2	Z8 40270	8	PANEL LOCK MOD.3997	
3	Z8 40271	8	CAM x CLOSURE 3997	[1]
4	Z8 35040	2	LATERAL PANEL 3997	[1]
5	Z8 17338	1	TANK BELT MOD.3997	[1]
6	Z8 36166	1	CAR MODEL 3997 FE STANDARD	[1]
7	Z8 18343	2	LIFTING BRACKET	[1]
11	Z8 40035	2	SQUARE PLUG 40 X 40 PVC	
15	Z8 16127	1	ACCESSORIES TANK 3997	[1]
16	Z8 40036	2	SQUARE PLUG 50 X 50 PVC	
17	Z8 39055	2	CABLE GLAND PG16 PA	
18	Z8 39035	mt. 2,2	CABLE 4G1.5 FROR AL M	
19	Z8 39263	1	CABLE GLANDPG29 OTT.	[2]
20	Z8 39034	mt. 9	CABLE 4G10 NEOPR. IN MT	
21	Z8 18344	1	HANDLE MODEL 3997	[1]
24	Z8 40250	2	CASTOR D250 PLATE	
29	Z8 40251	2	WHEEL FIX D250 MOD.3997	
32	Z8 14090	2	LIFTING LEVER MOD.3997	[2]
39	Z8 14038	2	RELEASE SHEAVE D560	
40	Z8 14074	1	LEVER RELEASE PUSH D560 FE	
42	Z8 36056	2	MOBILE SLIDER 3997	[2]
43	Z8 14076	2	HIGH PIN RELEASE D560	
46	Z8 39039	2	PLATE PASS D9	

Part Notes:

- [1] - CONTACT PM IN ZOCCA
[2] - SEE SM-SP-007

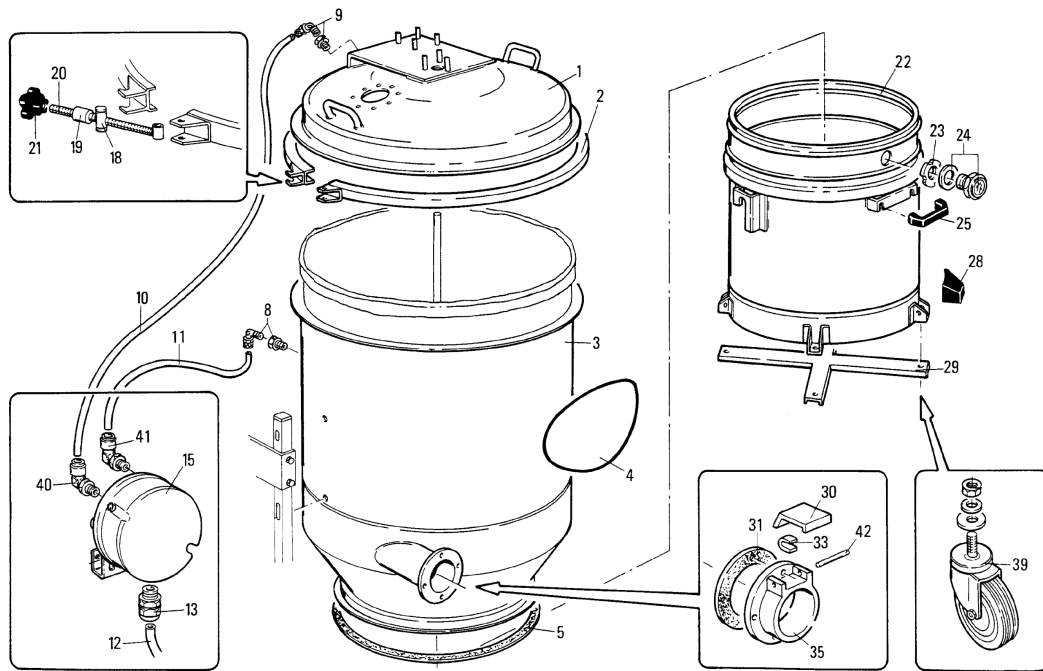

UNISTUDIO - Modena

No.	Part No.	Qty.	Description	Part Note
1	Z8 31111	1	CAP D780 FE HOLE D120 ELECT.FILT.SHAKER	
2	Z8 36192	1	BAND LOCK D.780	
3	Z8 31092	1	FILT.CHAMBER D780/560x935 FE MOD.3997	[1]
4	Z8 17083	1	GREEN LABEL CFM BIG GREEN	[2]
5	Z8 17055	1	FILTER CHAMBER SEAL D560	
8	Z8 40180	1	CONNECTION BENT SWIVEL 1/4MD8	
9	Z8 40180	1	CONNECTION BENT SWIVEL 1/4MD8	
10	Z7 24076	mt. 2		
11	Z7 24076	mt. 1,2		
12	Z8 39035	mt. 2,2	CABLE 4G1.5 FROR AL M	
13	Z8 39055	1	CABLE GLAND PG16 PA	
15	Z8 40265	1	PRESS. DIFFERENT. FILTER 150MBAR	
18	Z8 14172	1	CLOSING PIN D780	[1]
19	Z8 14170	1	LOCK SPACER D780	[1]
20	Z8 14171	1	LOCK TIE ROD D780	[1]
21	Z8 40030	1	KNOB D60 M10 THROUGH	
22	Z8 30025	1	CONTAINER D560X700 LT175 FE	
23	Z8 38001	1	INSP.WINDOW RING NUT D50	
24	Z8 40020	1	INSP.WINDOW D50	
25	Z8 40205	2	HANDGRIP BACHELITE CONTAINER	
28	Z8 17021	4	BUMPER WHEEL HOLDER	
29	Z8 36109	1	CONTAINER REINFORCEMENT D560	
30	Z8 32011	1	BUTTON FOR INLET D70/100	
31	Z8 17056	1	INLET SEAL D100	
33	Z8 13010	4	SPRING INLET D50	
35	Z8 13089	1	CRUSHED INLET D100	[3]
39	Z8 40008	4	CASTOR D100VULKOLAN	
40	Z8 40150	1	CONNECTION BENT 1/4M D6	[1]
41	Z8 40179	1	CONNECTION BENT SWIVEL 1/8MD6	
42	Z8 38020	2	ELASTIC PIN 3X16	

Part Notes:

- [1] - SEE SM-SP-007
- [2] - NO MORE AVAILABLE
- [3] - CONTACT PROD MANAGEMENT

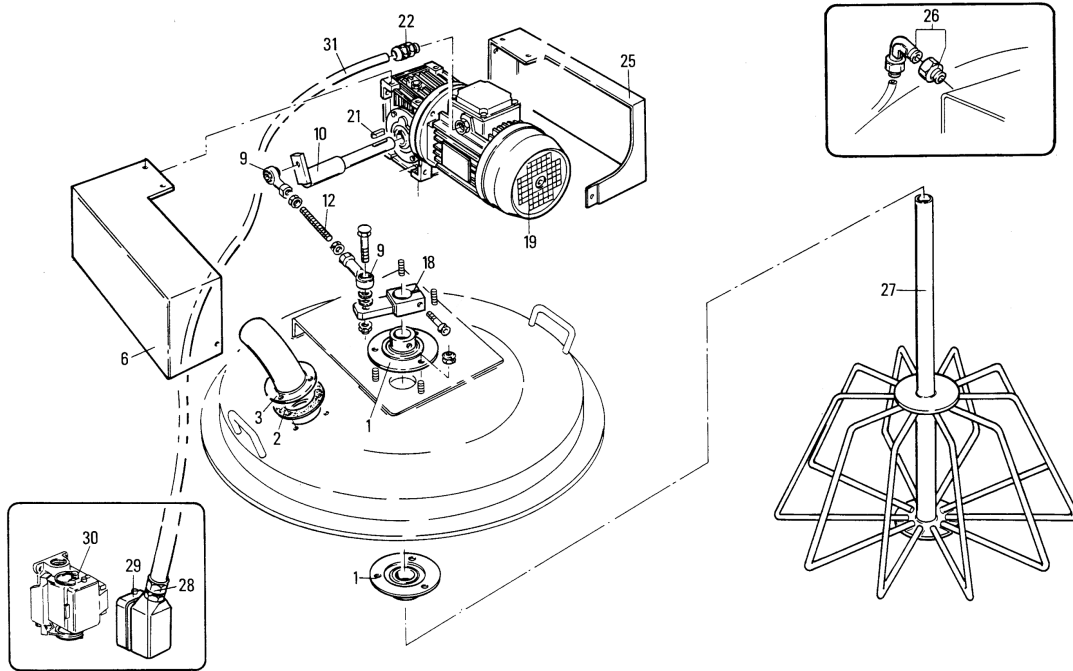

UNISTUDIO - Modena

No.	Part No.	Qty.	Description	Part Note
1	Z8 38012	2	SUPPORT BEARING D30 FILTER SHAKER	[1]
2	Z8 17056	1	INLET SEAL D100	
3	Z8 32118	1	BENT COUPL. D100 FL150 ZINC.	
6	Z8 16090	1	CARTER ELEC.F.SHAKER D780	[2]
9	Z8 38007	2	UNIBOL D12 M12 FEMALE	
10	Z8 34019	1	PIN ELECT.FILTER SHAKER D780	[2]
12	Z8 38040	1	TIRANTE	
18	Z8 34018	1	ELECTRIC/FS LEVER D780	[2]
19	Z8 56009	1	GEARBOX FILT.SHAKER D780	
21	Z8 38016	1	KEY 6X30	[2]
22	Z8 39055	1	CABLE GLAND PG16 PA	
25	Z8 16090A	1	CARTER ELEC.F.SHAKER D780	[2]
26	Z8 40180	1	CONNECTION BENT SWIVEL 1/4MD8	
27	Z8 33116	1	STAR CAGE D780 ELECTRIC	
28	Z8 39055	1	CABLE GLAND PG16 PA	
29	Z8 39327	1	MOBILE CASE x 6P+E ILME	
30	Z8 39328	1	FIX CASE X 6P+E ILME METAL IP65	
31	Z8 39035	Mt. 2,5	CABLE 4G1.5 FROR AL M	

Part Notes:

- [1] - SEE SM-SP-007
 [2] - CONTACT PM IN ZOCCA

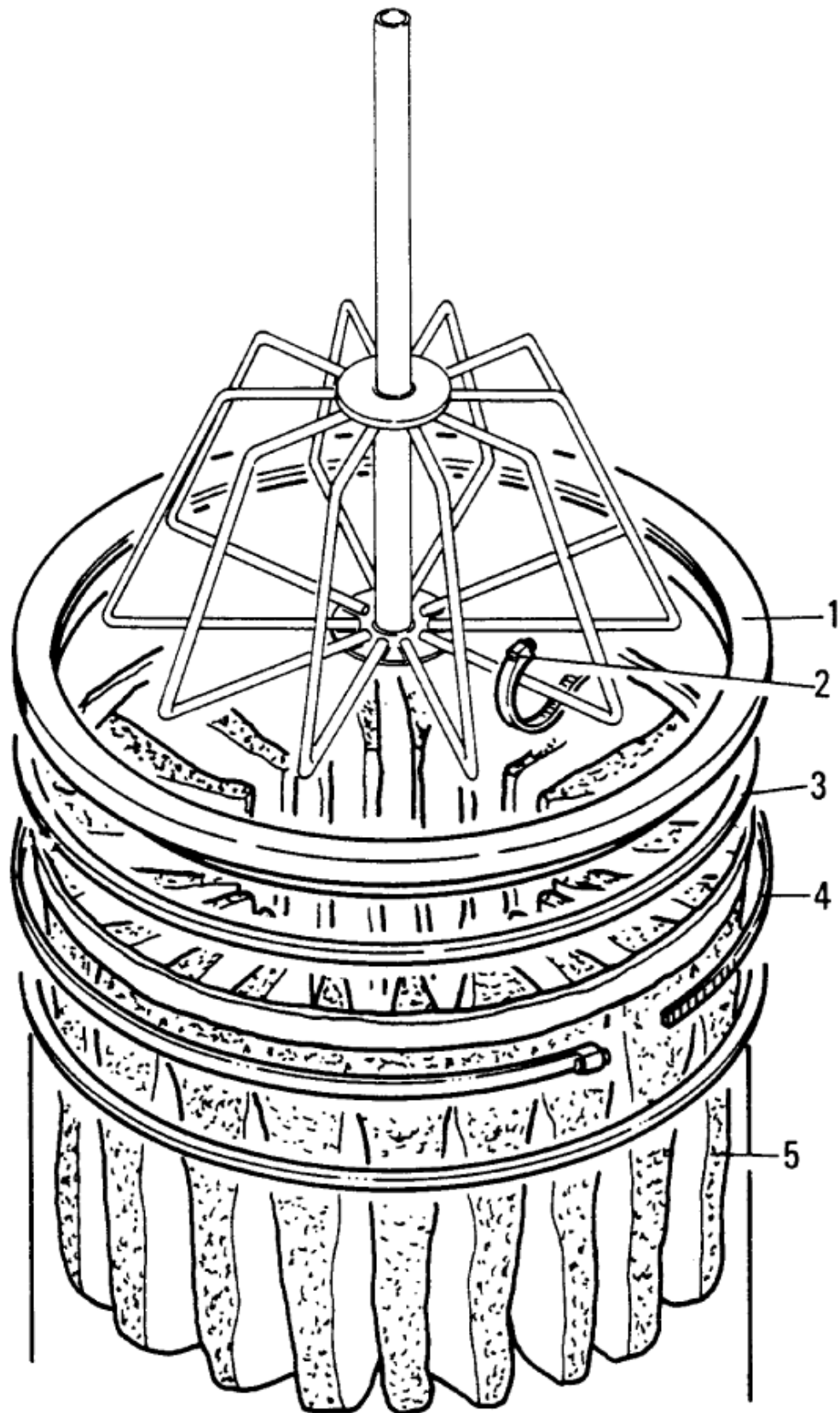

No.	Part No.	Qty.	Description	Part Note
00	Z8 33138	1	FILTER COM.ST.D780	[1]
01	Z58 17285	1	FILTER SEAL D780 BLACK	
02	Z8 40053	12	TIE X FILTERS PVC 120X7.8	
03	Z8 15084	1	FILTER HOLDER RING D780 F	
04	Z8 18074	1	FILTER BLOCK TIE D780	
05	Z8 17160	1	STAR FILTER 780 POLYESTER	

Part Notes:

[1] - POS. 1-5

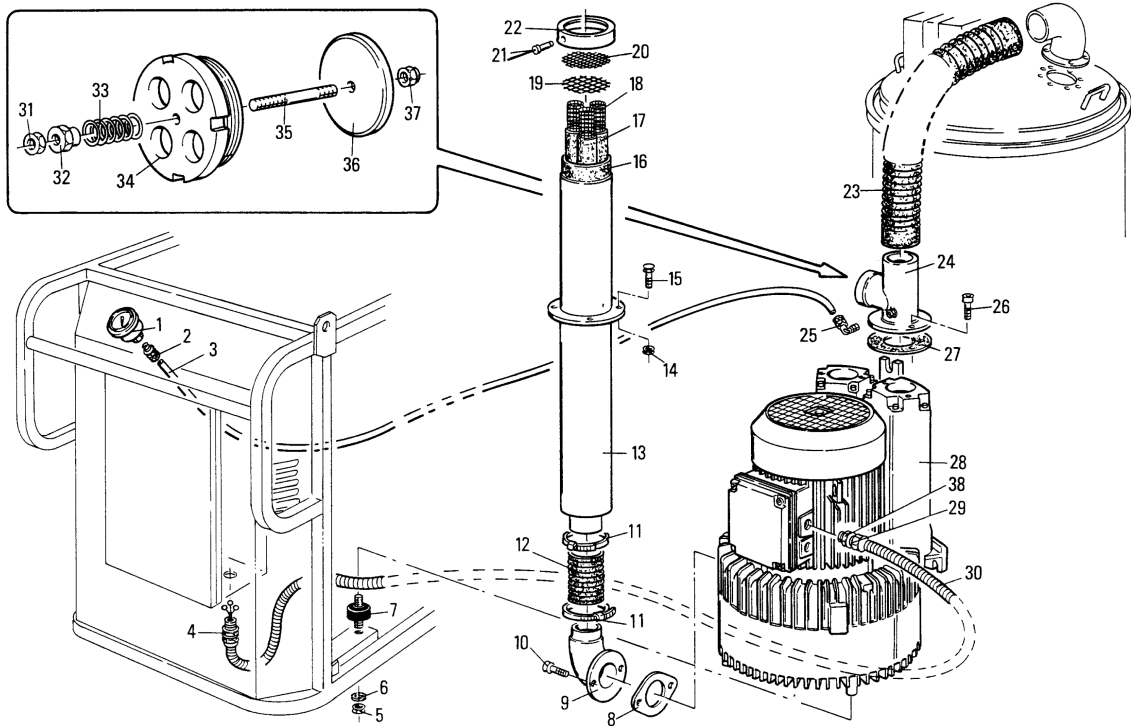

No.	Part No.	Qty.	Description	Part Note
1	Z8 40247	1	VACUUM GAUGE D63 MOD.3997 0/-76 CMHG	
2	Z8 40196	1	CONNECTION STRAIGHT 1/4F D6	
3	Z8 24076	mt. 1,2	TUBE RILSAN 6X4 X VAC. GAUGE	
4	Z8 39309	2	CABLE GLAND PG21 x SHEATH D22	[1]
7	Z8 40063	3	PAD D60X30 M12 2M	
8	Z8 17256	2	SEAL X CONNECTIONS HP18	
9	Z8 32195	1	CONNECTION BLOWING 3997SERIES	[1]
11	Z8 40044	2	TIE D90-110	
12	Z7 24079	mt. 0,3	TUBE RUBBER D100 IN METERS	[1]
13	Z8 32196	1	MUFFLER D150 MOD. 3997	[2]
16	Z8 13120	2	MUFFLER SPONGE D150	
17	Z8 13121	6	TUBE SPONGE MUFFLER D150	
18	Z8 13122	6	MUFFLER MESH TUBE D150	
19	Z8 13124	1	NET D150 MESH 12X12	
20	Z8 13123	1	NET D150 MESH 6X6	
22	Z8 13115	1	MUFFLER COVER D150 FE	
23	Z8 13156	1	CONNECTION TUBE 3707/3907	
24	Z8 32193	1	CONNECTION SUCTION 3997SERIES	[1]
25	Z8 40045	1	CONNECTION 1/8M D6 BENT	
27	Z8 17256	1	SEAL X CONNECTIONS HP18	
28	Z4 55300	1		
29	Z8 39205	2	CABLE GLAND PG21 PA	[1]
30	Z8 39086	mt. 2,5	CABLE 4G6 NE. AL M	
33	Z8 14251	1	SPRING X P.R.VALVE 3	[1]
34	Z8 14282	1		
35	Z8 14284	1	PERNO	
36	Z8 14286	1	DISCO	
37	Z8 40385	2	REDUCER PG29M/PG21F	[3]

Part Notes:

- [1] - CONTACT PM IN ZOCCA
- [2] - SEE SM-SP-007
- [3] - GUARANTEE DATE EXPIRED

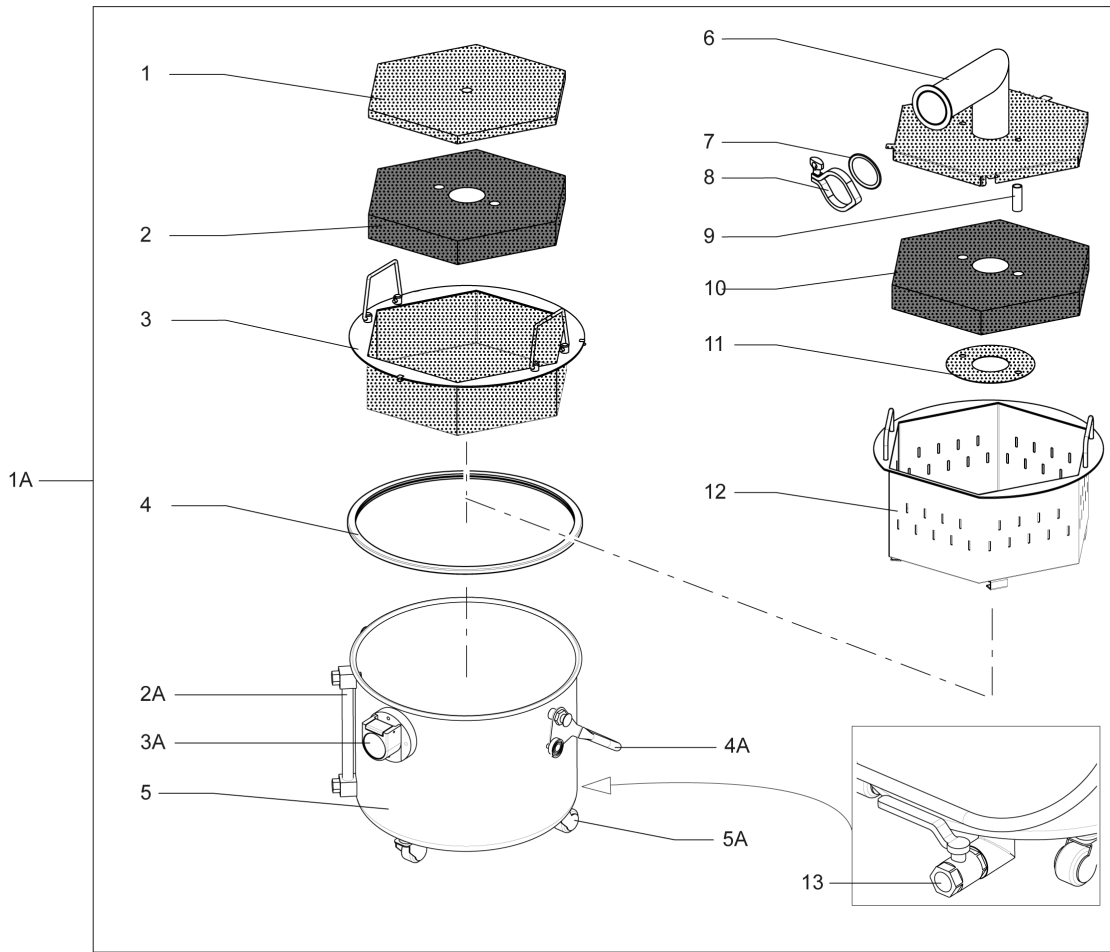

OPTIONALS

3997W std

2018.08.21

2017.08.15

No.	Part No.	Qty.	Description	Part Note
1	4081600718	1	COMPRESSOR FRAME M.3997 C FE	
2	4081300361	1	DIFFUSER TUBE NET 3997 D350x220	[1]

Part Notes:

[1] - CONTACT PM IN ZOCCA

