

Instruction manual

EVO1!

Instruction Manual



PINGuard™

PINGuard™

EVO1i

Instruction manual

Important Information Please Read First

• **Warning! Do not fit when surface temperature is below 10°C/50°F (see Adhesive information)**

- All safety equipment to be provided by installer
- Fitting template is a guide and for some ATMs may not be needed
- For all Material Safety Data Sheets please email support@pinguard.com
- For full terms and conditions please email support@pinguard.com

Adhesive Information

The VHB tape adhesive takes 3 days to reach full 100% strength. The VHB adhesive is covered in microscopic bubbles filled with liquid adhesive. When the tape is pressed onto the ATM fascia, the pressure bursts the bubbles and releases the liquid adhesive that bonds to the ATM. When the environment is cold (which is why we say not to fit below 10°C/50°F) the liquid doesn't flow correctly which makes the bond weak. Also if there is any grease, moisture or dirt on the surfaces this will greatly reduce the bond strength and may cause the bond to fail (this can be seen if there is no adhesive residue left over on the ATM fascia). The primer helps the adhesive bond to the ATM and speeds up the curing process.

For other translations of this instruction sheet please email support@pinguard.com

www.PINGuard®.com

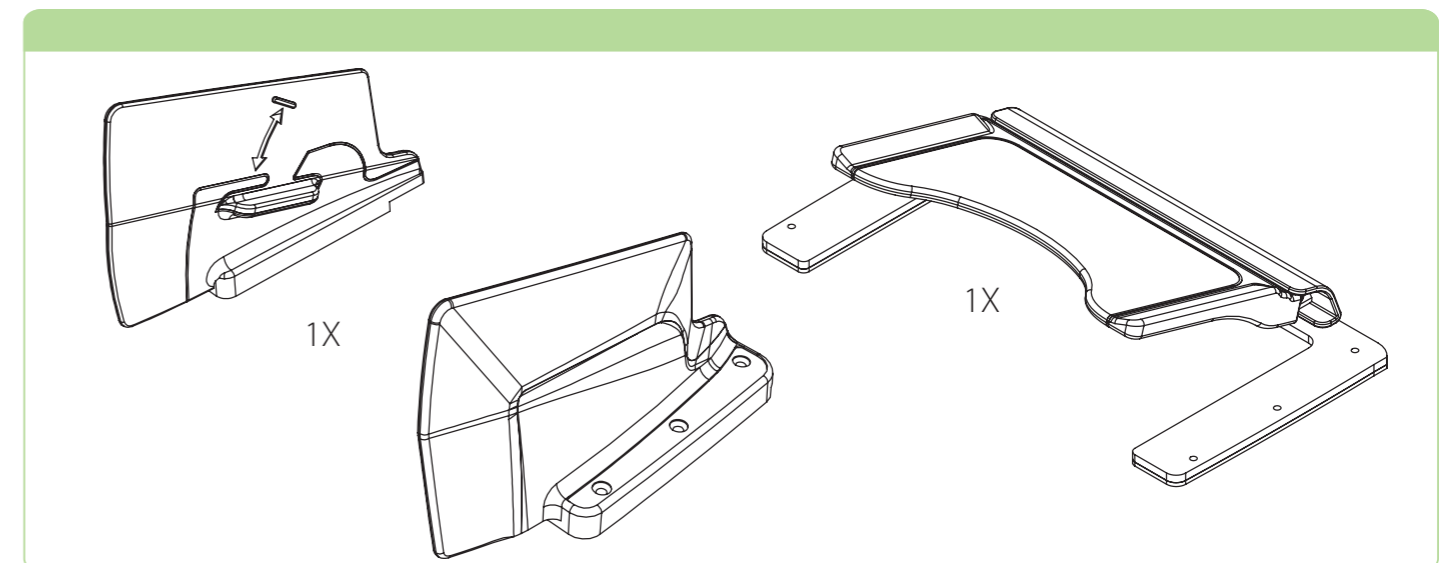
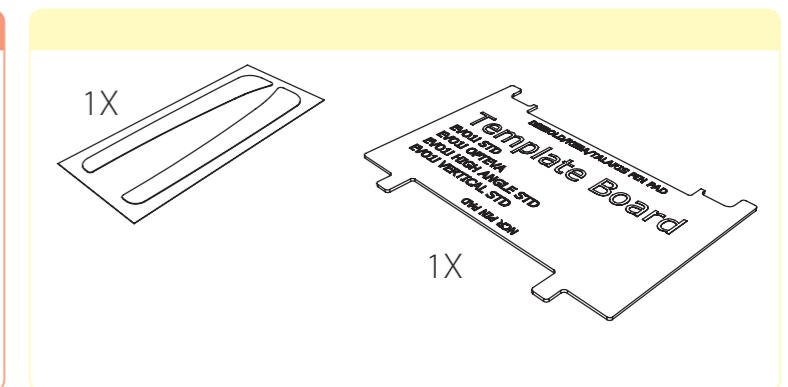
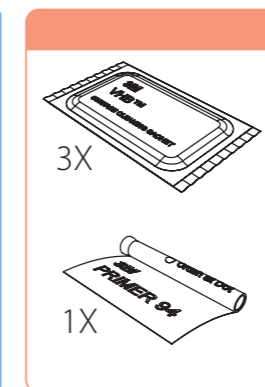
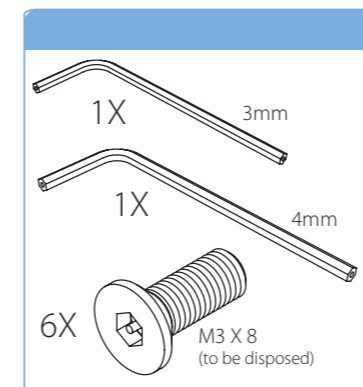

Fitting Instructions

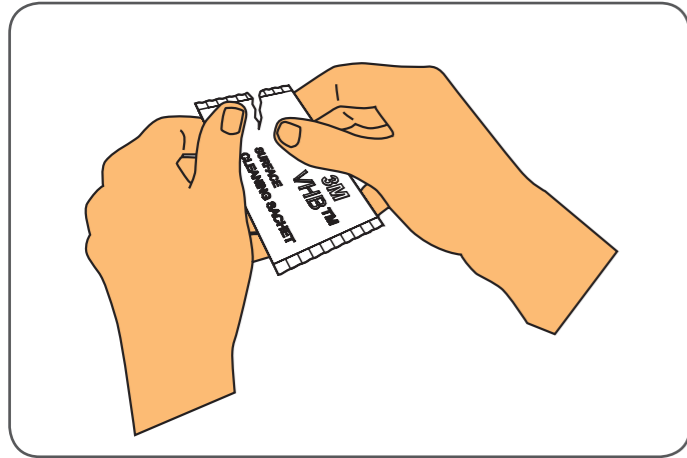

Step 1: Open cleaning sachet.

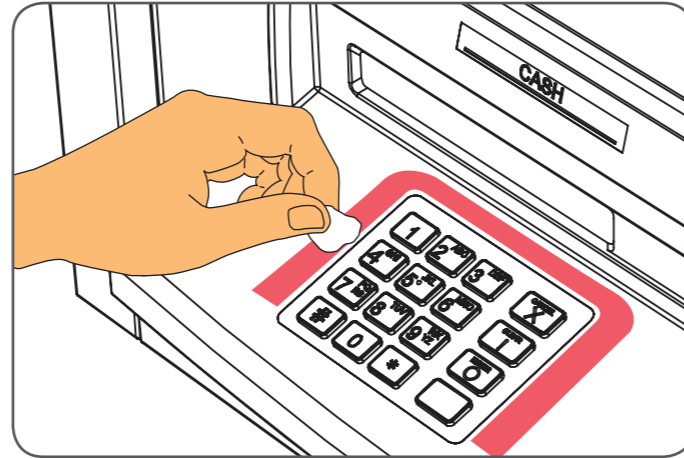

Step 2: **Thoroughly clean the area shown** using cleaning sachets provided. All three sachets may be required to ensure that it is absolutely clean. The area around the PIN Pad must be completely clean for the best adhesion. Allow to dry for 5 minutes.

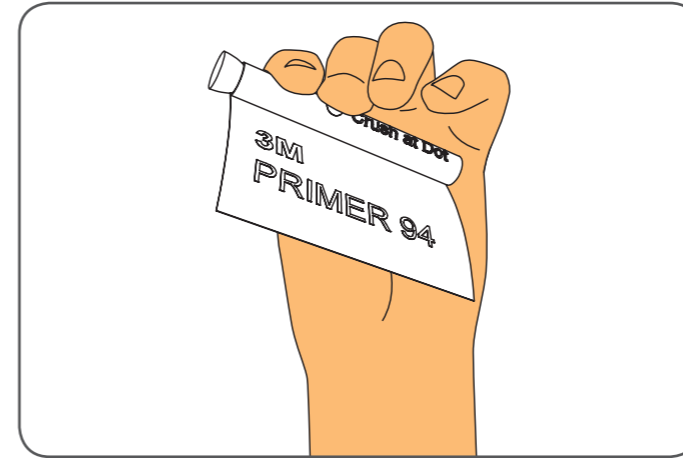

Step 3: Break primer ampoule by firmly pressing the black dot on the container, which will produce a popping sound. Keep squeezing the dot until liquid appears on the application pad at the end of the ampoule and continue doing so until all the liquid has been used.

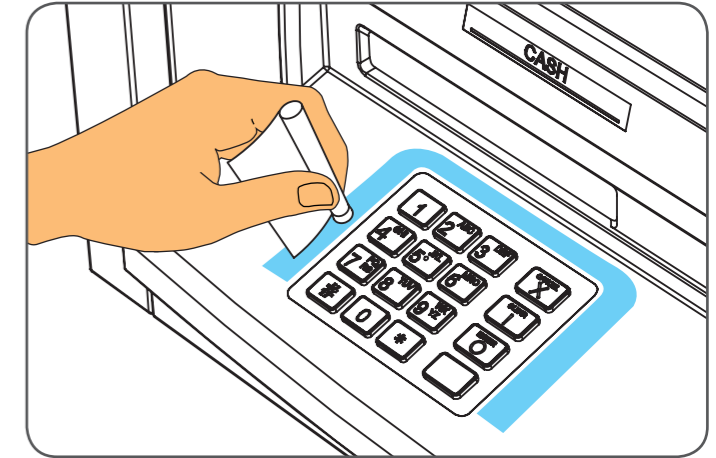

Step 4: Brush the primer onto the area shown. Ensure complete coverage of PINGuard® footprint area. Allow to dry for 5 minutes.

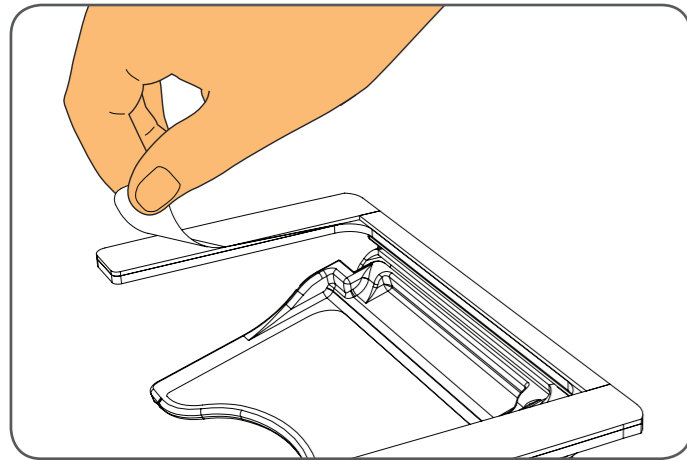

Step 5: Peel tape from the base of the PINGuard® ensuring that you do not touch the adhesive surface.

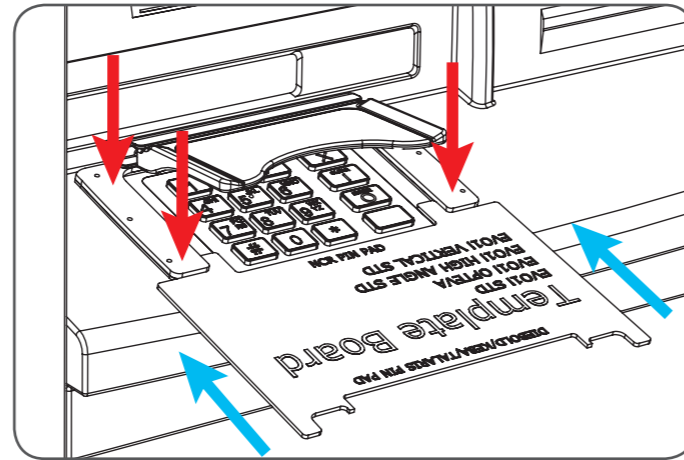

Step 6: Place the PINGuard® onto the ATM so that the base lines up with the template board as shown.

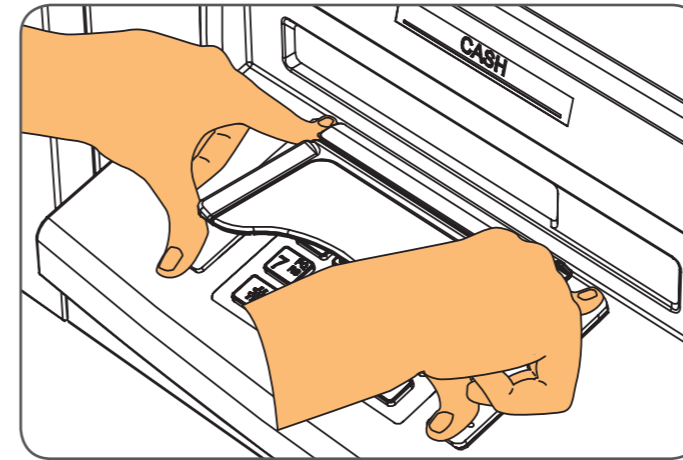

Step 7: Once correctly aligned and fitted, **apply heavy pressure to the base for at least 2 minutes!** This will remove any air bubbles and is vital for good adhesion. Leave for 5 minutes for bond to cure.

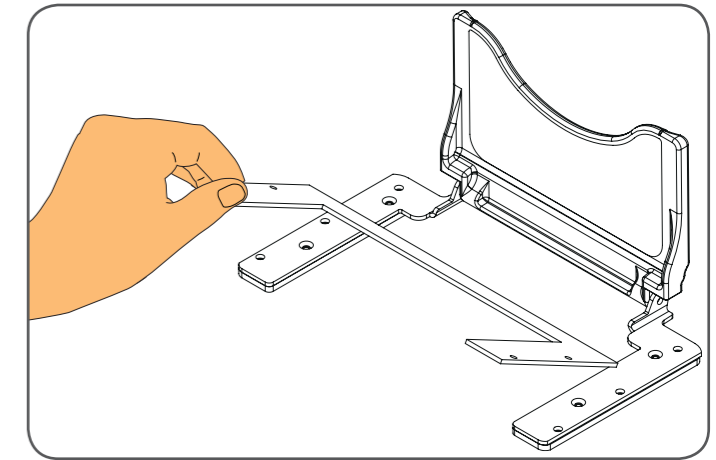

Step 7a: When fitting an EVO1i Recess you will now need to unscrew and remove the U shaped metal bracket.

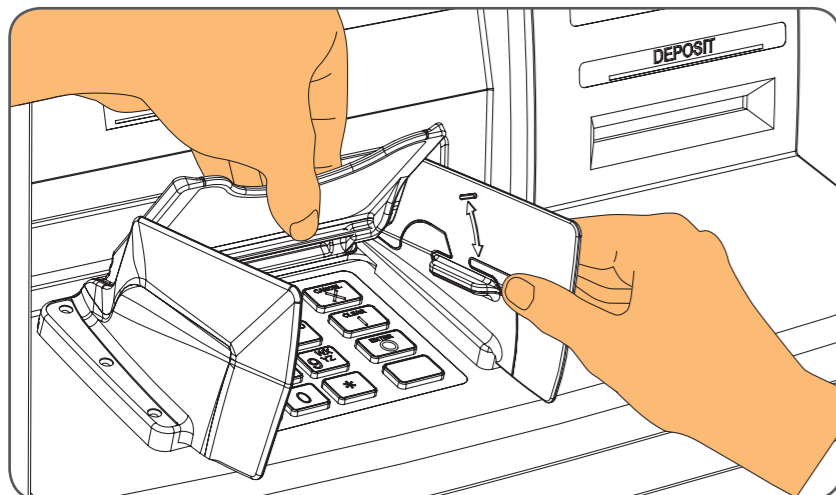

Step 8: Lift the lens up and slide the wings as shown.

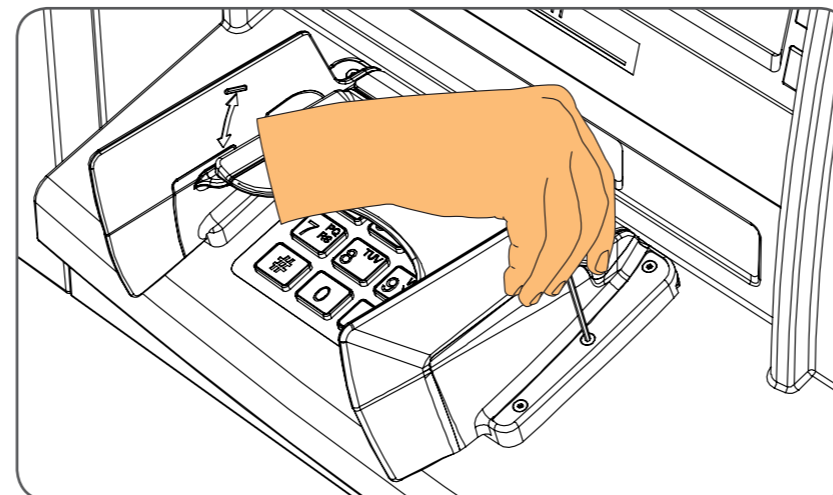

Step 9: Screw the wings down by using the screws provided. **Do not over-tighten**

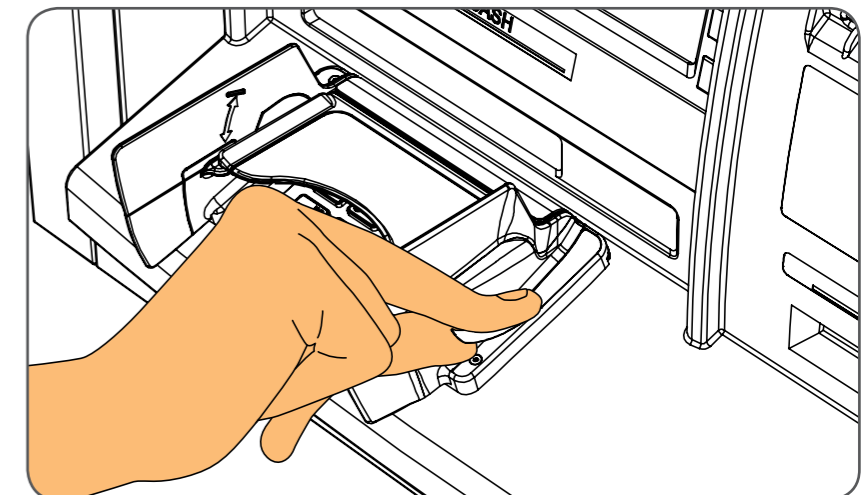

Step 10: Using the cleaning sachet, thoroughly wipe the area around the PINGuard® to ensure that any residue primer is removed. Then finally fit cover labels as shown.