



Flexineb Mask Adapter Kit

Instructions for Use



Intended Use:

Use the Flexineb Mask Adapter and Inlet Valve Kit if you cannot achieve a good seal between the Flexineb Mask and the horse's muzzle. A poor fitting Flexineb Mask will mean air leaks around the muzzle of the horse and the Aerosol Chamber will not empty fully each time the horse inhales. When fitted the Mask Adapter will create a very good seal around the muzzle of the horse, this is important for correct airflow through the system. The supplied Inlet Valve has larger air inlets to ensure your horse inhales plenty of fresh air with the Mask Adapter fitted. The Flexineb Mask Adapter will fit both the Standard and Large size Flexineb Masks.

Safety Statement:

It is very important to replace the old Inlet Valve on the Chamber (which may be an older revision with smaller air inlets) with the new supplied Inlet Valve. When re-introducing your horse to the Flexineb Mask with the Adapter Kit fitted, open the Exit Valve in the bottom of the Mask to ensure plenty of air intake is available. Observe your horse for any sign of anxiety with the new Mask Adapter and Valve fitted and slowly close the Exit Valve in the bottom of the Mask. Once your horse is comfortable, relaxed, and breathing normally you can begin nebulisation.

Fitting Instructions:

1. Remove the old Inlet Valve from the Chamber and fit the new one supplied
2. If the Inlet Valve is difficult to remove or re-fit placing the parts in warm water will help soften the plastic
3. To fit the new Mask Adapter, align the slot at the front of the Adapter with the front of the Mask
4. Pull each Strap through the side slots in the Adapter and slide it over the Mask
5. Refit the Chamber with new Inlet Valve to the Mask by engaging the top latch and then pushing the Mask onto the Chamber firmly to ensure a secure fit

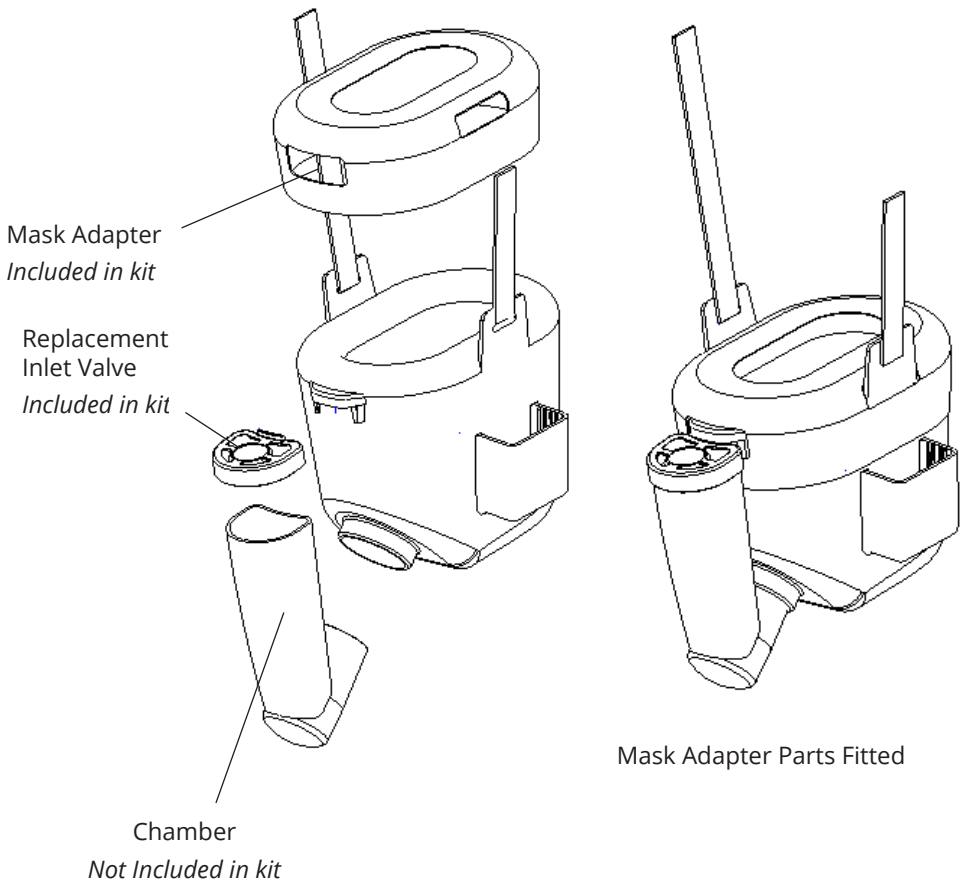

Flexineb[®]+

NOW AVAILABLE ON THE APP STORE



Designed and manufactured by:
Nortev Ltd. | Galway | Ireland

www.flexineb.com