

# HBS

S E R I E S

## Datasheet

- EFFICIENT
- POWERFUL
- SAFE

## Technical Specifications

### HBS-100

Wattage 100W  
Lumens 11,839lm  
Weight 1.3kg

[Download .IES file](#)

### HBS-150

Wattage 150W  
Lumens 17,850lm  
Weight 2.3kg

[Download .IES file](#)

### HBS-200

Wattage 200W  
Lumens 24,289lm  
Weight 2.3kg

[Download .IES file](#)

## HBS Specification

### Colour Temperature

5000K Standard

**CRI**  
75

### Input Voltage

AC220-240V

### Power Factor

>0.99

### Thermal Management

YES

### Body Composition

AZ91D Aluminium

### Lens Composition

PC Lens

### Temperature Range

-40°C ~ +50°C

### Cable

1m flex and plug

\*3000K or 4000K Available On Request



> 60,000 HRS (L70)



IP65 RATING



IK10 RATING



WARRANTY

## Key features

- Integrated driver solution
- Magnesium-aluminium alloy heat sink
- Advanced Graphene Technology
- Low flicker and intelligent control supported
- Low UGR reflector, UGR≤19
- Quality Nichia LED Chip

## Applications

- Storage facilities
- Warehouse lighting
- Indoor sporting centres

## Dimensions

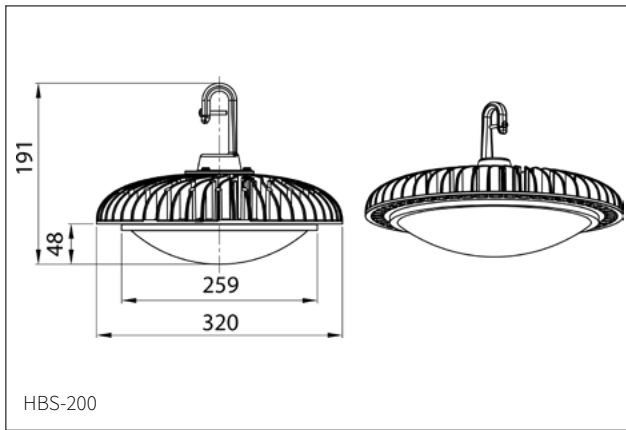
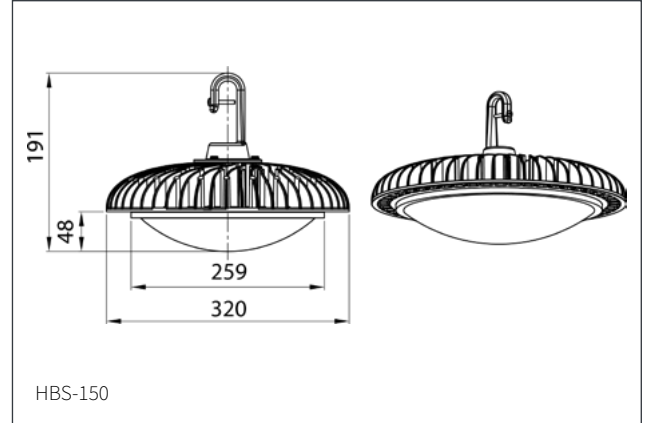
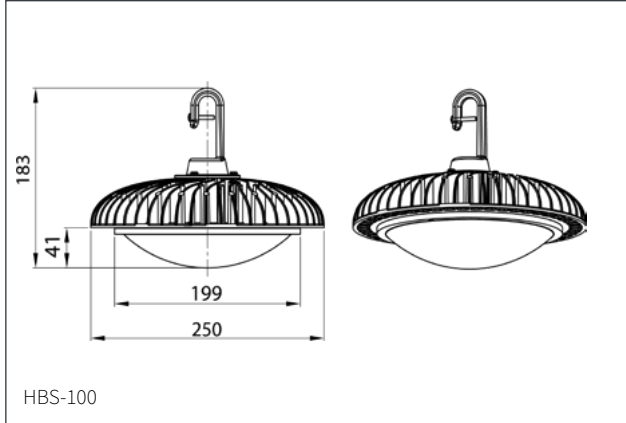

## Ordering Matrix

**HBS** - **100** - **120**  
Series Wattage Beam angle

Series	Wattage	Beam Angle
HBS	100	120°
HBS	150	120°
HBS	200	120°

## Light Distribution

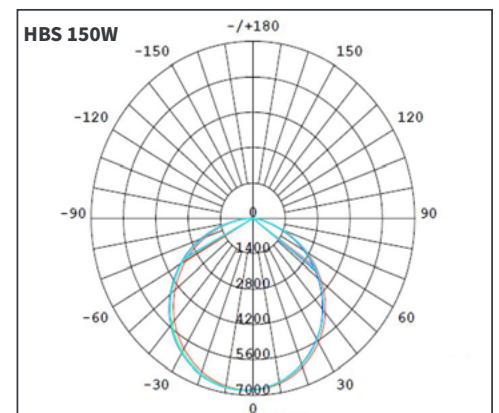

\* Specifications subject to change without notice.