

90W SPOT MOVING HEAD USER MANUAL

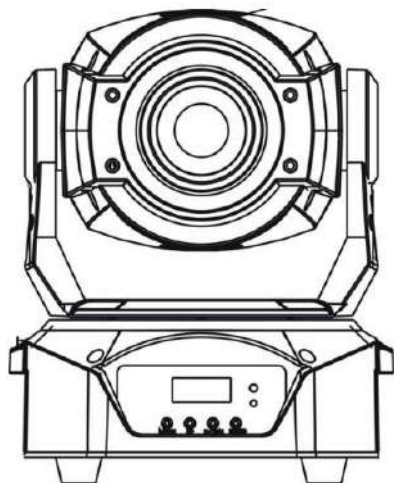

TABLE OF CONTENTS

1. BEFORE YOU BEGIN

- WHAT IS INCLUDED
- UNPACKING INSTRUCTIONS
- MANUAL CONVENTIONS
- ICONS
- SAFETY INSTRUCTIONS

2. INTRODUCTION

- TECHNICAL SPECIFICATION
- PRODUCT DIMENSIONS
- PRODUCT OVERVIEW

3. SETUP

- AC POWER
- POWER LINKING
- SIGNAL LINKING (DMX)
- FUSE REPLACEMENT
- MOUNTING ORIENTATION RIGGING

4. OPERATING INSTRUCTIONS

- CONFIGURING THE STARTING ADDRESS
- CONTROL PANEL FUNCTIONS
- MENU MAP
- DMX CHANNEL VALUES

5. APPENDIX

- DMX PRIMER
- GENERAL MAINTENANCE
- FIXTURE LINKING
- DATA CABLING
- DMX DATA CABLE
- CABLE CONNECTORS
- 3-PIN TO 5-PIN CONVERSION CHART
- SETTING UP A DMX SERIAL DATA LINK
- SETTING THE STARTING ADDRESS
- GENERAL TROUBLESHOOTING

1. BEFORE YOU BEGIN

What is included

- 1 x Spot
- 1 x Mounting bracket and screws
- 1 x Power cable
- 1 x User Manual

Unpacking Instructions

Immediately upon receiving a fixture, carefully unpack the carton, check the contents to ensure that all parts are present, and have been received in good condition. Notify the shipper immediately and retain packing material for inspection if any parts appear damaged from shipping or the carton itself shows signs of mishandling. Save the carton and all packing materials. In the event that a fixture must be returned to the factory, it is important that the fixture be returned in the original factory box and packing.



Manual Conventions

manuals use the following conventions to differentiate certain types of information from the regular text.

CONVENTION	MEANING
[10]	A LCD display to be configured
<Menu>	A key to be pressed on the fixture's control panel
1~512	A range of values
50/60	A set of values of which only one can be chosen
<i>Settings</i>	A menu option not to be modified (for example, showing the operating mode/current status)
MENU > Settings	A sequence of menu options to be followed
ON	A value to be entered or selected

Icons

This manual uses the following icons to indicate information that requires special attention on the part of the user.

ICONS	MEANING
	<p>This paragraph contains critical installation, configuration or operation information. Failure to comply with this information may render the fixture partially or completely inoperative, cause damage to the fixture or cause harm to the user.</p>
	<p>This paragraph contains important installation or configuration information. Failure to comply with this information may prevent the fixture from functioning correctly.</p>
	<p>This paragraph reminds you of useful, although not critical, information</p>

Safety Instructions



Please read these instructions carefully. It includes important information about the installation, usage and maintenance of this product.

- Please keep this User Manual for future consultation. If you sell the unit to another user, be sure that they also receive this instruction booklet.
- Always make sure that you are connecting to the proper voltage, and that the line voltage you are connecting to is not higher than that stated on the decal or rear panel of the fixture.
- This product is intended for indoor use only! To prevent risk of fire or shock, do not expose fixture to rain or moisture.
- Make sure there are no flammable materials close to the unit while operating.
- The unit must be installed in a location with adequate ventilation, at least 20 in (50 cm) from adjacent surfaces. Be sure that no ventilation slots are blocked.
- Always disconnect from power source before servicing or replacing fuse and be sure to replace with same fuse source.
- Secure fixture to fastening device using a safety chain.
- Maximum ambient temperature (Ta) is 104° F (40° C). Do not operate fixture at temperatures higher than this.
- In the event of a serious operating problem, stop using the unit immediately.

Never try to repair the unit by yourself. Repairs carried out by unskilled people can lead to damage or malfunction. Please contact the nearest

authorized technical assistance center.

- Never connect the device to a dimmer pack.
- Make sure the power cord is never crimped or damaged.
- Never disconnect the power cord by pulling or tugging on the cord.
- Never carry the fixture directly from the cord. Always use the hanging/mounting bracket.
- Avoid direct eye exposure to the light source while it is on.
- Never carry the fixture by holding the head. Always use the carrying handle.

2. INTRODUCTION

Technical Specification

- 1) Voltage: 100-240V,50-60Hz
- 2) Power consumption: 110W
- 3) LED: ultra bright 90W LED
- 4) LED color wheel: Basic 7 colors+ white, can adjust speed rainbow effect
- 5) Fixed gobo: 8 gobos+ white, Gobo rotating CW and CCW from slow to fast), gobo shaking
- 6) Rotation gobo: 6 gobos + white, can bidirectional speed change rotation, gobo shaking
- 7) Dimmer/Strobe: Dimmer, 1-20t/s
- 8) Focus: Electronic Focus
- 9) Pan::540° Tilt: 270
- 10) Control: DMX 512, 14/16 /11CHs
- 11) Working mode: Stand-alone mode, Controller mode, Master/Slave synchronization mode
- 12) Other function: Pan/Tilt speed adjustable
Housing: High temperature resistant engineering plastic + aluminum alloy.
- 13) Weight: 6.5KG
- 14) Product Size: 240*240*370mm
- 15) Packing Size: 350*340*375mm

Product Dimensions

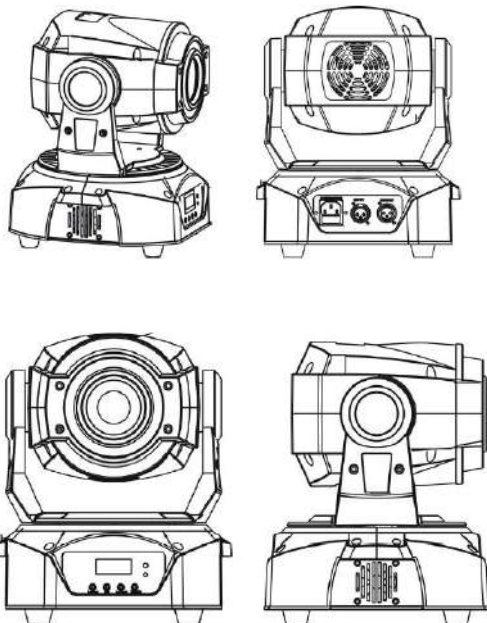

Product Overview

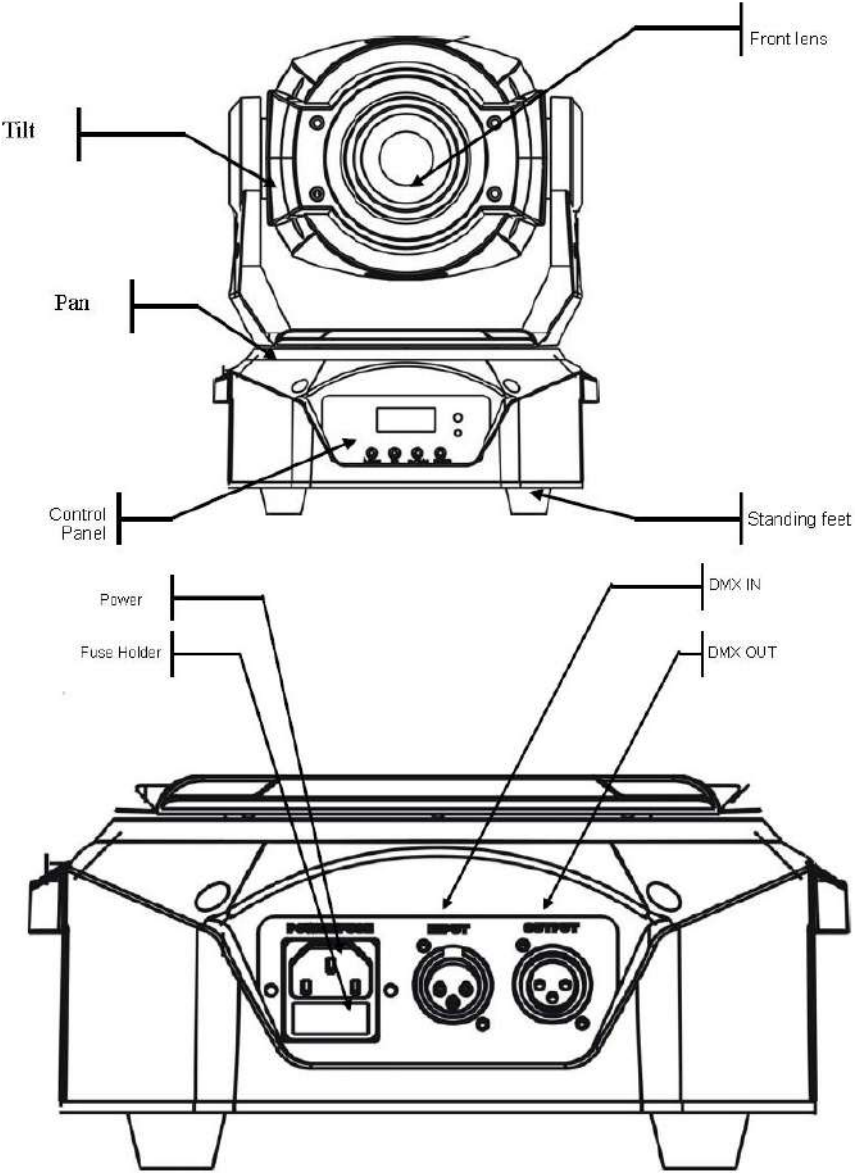

3. SET UP

AC Power

This fixture runs on 100-240VAC, 50/60 Hz. This fixture used switch power supply, it can transform by itself when user input power.



Always connect the fixture to a switched circuit. Never connect the fixture to a rheostat (variable resistor) or dimmer circuit, even if the rheostat or dimmer channel is used only as a 0 to 100% switch.



Always connect the fixture to a circuit with a suitable electrical ground.

The maximum quantity of fixtures that may be linked is 4.

Power Linking

This fixture contains power linking via the outlet located in front of the power input cable. Please see the diagram below for further explanation.

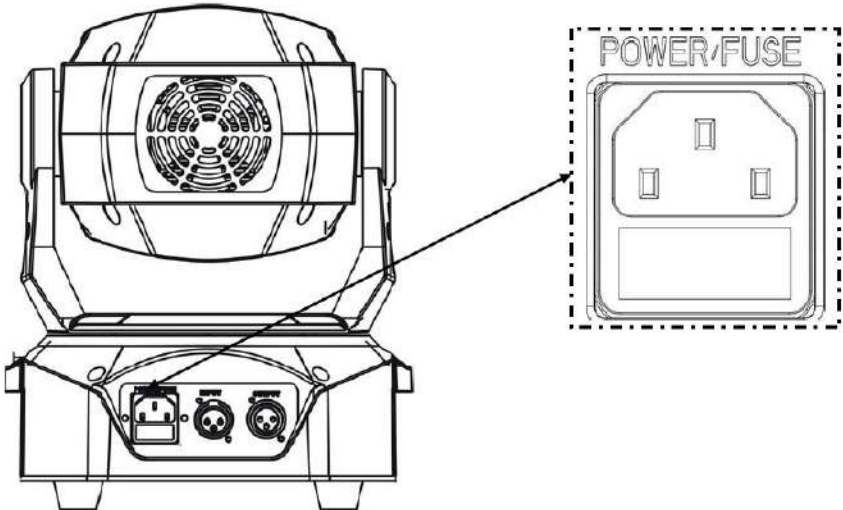

Signal Linking (DMX)

The diagrams below illustrate the signal (DMX) linking for this fixture. This is used both in DMX mode and when operating the fixtures in Master/Slave mode. Please see the diagram below for further explanation.

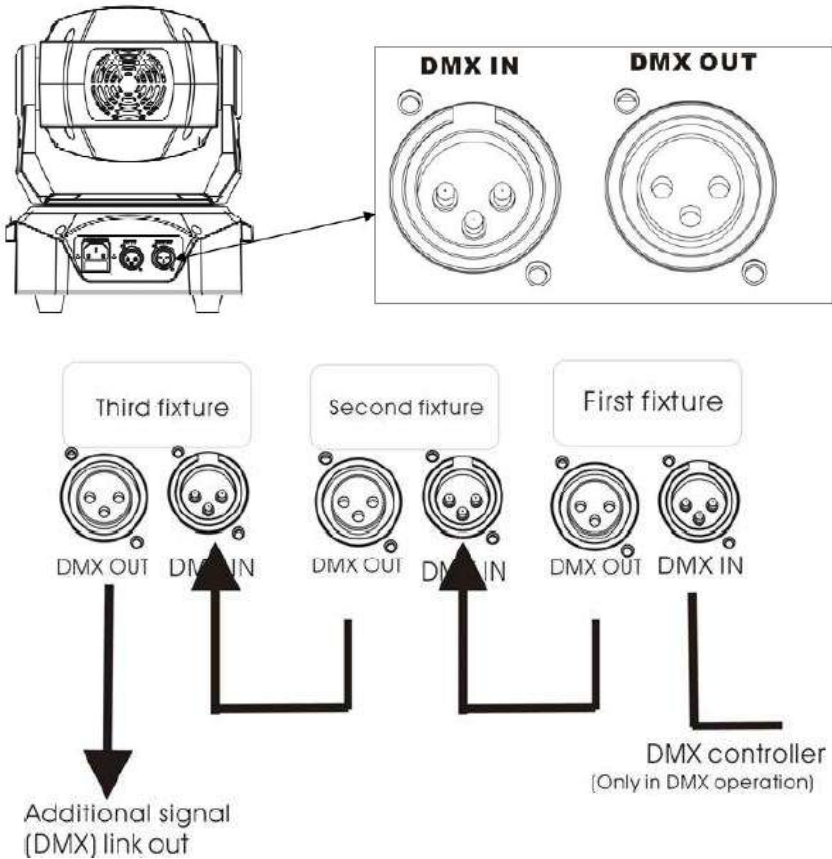

Fuse Replacement



Disconnect the power cord before replacing a fuse and always replace with the same type fuse.



With a flat head screwdriver unscrew the fuse holder out of its housing, turning counter-clockwise. Remove the damaged fuse from its holder and replace with exact same type fuse. Insert the fuse holder back in its place and reconnect power.

The fuse is located inside this fuseholder.

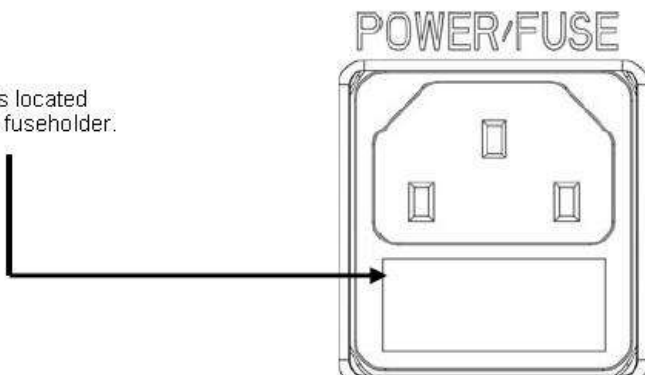

Mounting Orientation

The Spot may be mounted in any safe position provided there is adequate room for ventilation.

Rigging

Be sure that the structure can support 10 times the weight of the fixture. Please see the "Technical Specifications" section of this manual for a detailed weight listing. Mount the fixture securely. Two hanging clamps for truss mounting may be used, or nuts and bolts for permanent installation may be used. The holes in each bracket are 13 mm in size. When rigging, consider routine maintenance and control panel access. Please see the following steps for installation.

- If the power link out is intended to be used with multiple fixture, take into account the length of each power cable, and mount the fixtures close enough to one another to accommodate for this.
- Attach both included bolts in the locations indicated below, using a metric 8 mm Allen wrench.
- Attached 2 hanging clamps to the bracket in each of the two locations indicated below
- Safety cables must always be used.



Do NOT mount this fixture sideways!

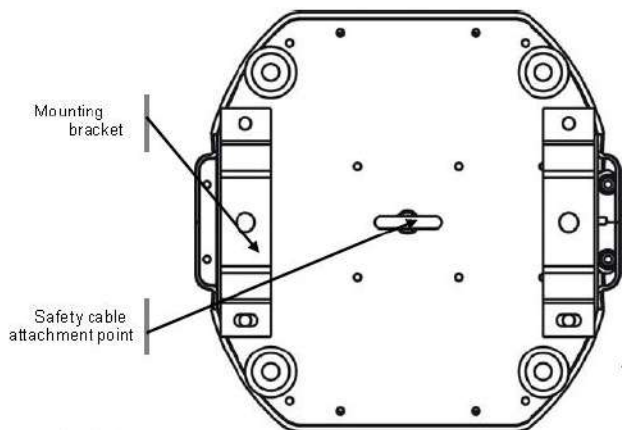

Mounting bracket

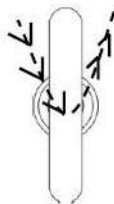

Be sure to loop the safety cable through the 1 loop, as shown in the illustration above.

The safety cable must be capable of support up to 10 times the weight of the fixture.

4. OPERATING INSTRUCTIONS

Configuring the Starting Address

Each fixture requires a starting address from 1~512. A fixture requiring one or more channels for control begins to read the data on the channel indicated by the starting address. For example, a fixture that uses seven DMX channels and is addressed to start on DMX channel 100, will read data from channels: 100, 101, 102, 103, 104, 105 and 106. Choose the starting addresses for each fixture so that the channels used do not overlap. In addition, you should note the starting address selected for future reference.

Control Panel Functions

The Control Panel shows the current state of the unit. It is used to select the operating mode, as well as the sub-features. For a detailed layout of the control panel functions, please see the “menu map” section on the following page.



[MENU] menu selection or return to previous menu.

[UP] press [UP] through the menu list to increase/change the value of the current function.

[DOWN] press [DOWN] through the menu list to decrease/change the value of the current function.

[ENTER] confirm & quit out current function setting.

Menu Map

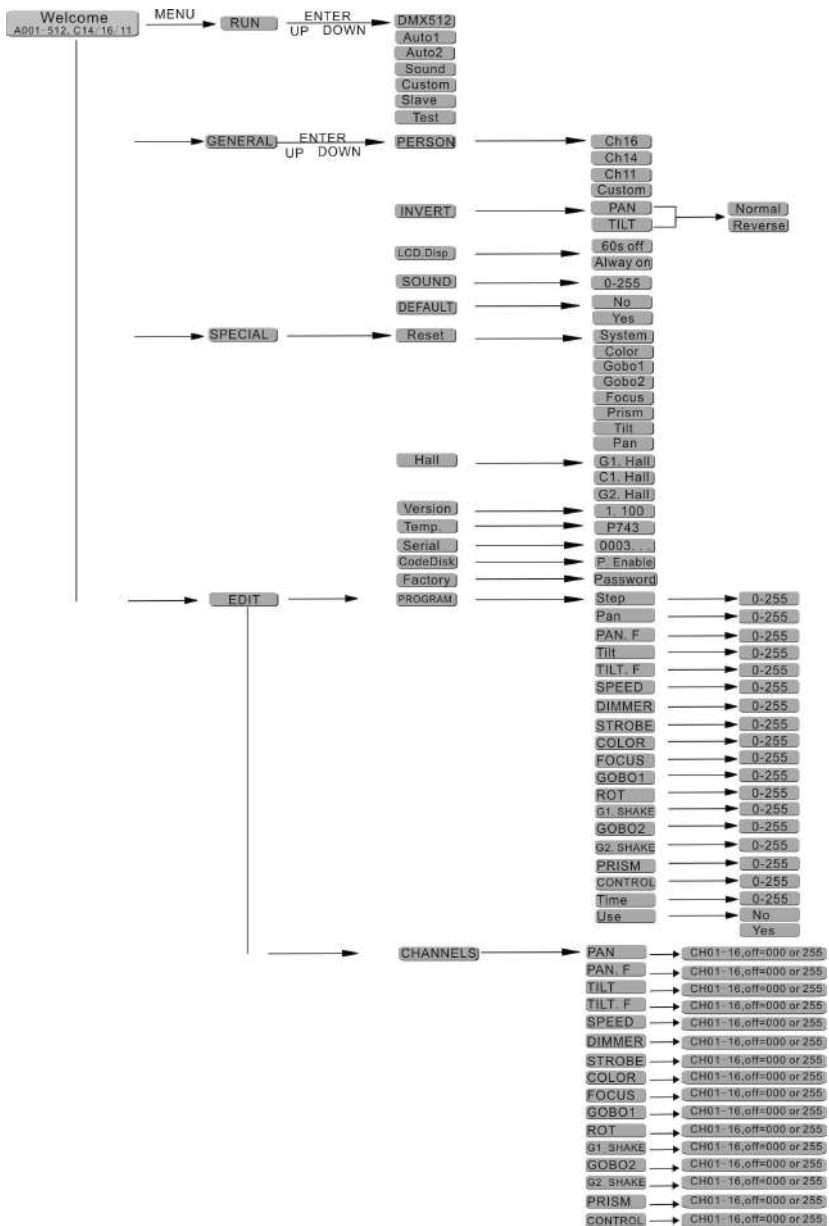

DMX CHANNEL VALUES 16-Channel Mode

16 CHS	CH value	Function
1CH X rotation	000-255	X rotation 0°-540°
2CH X fine adjustment	000-255	X fine adjustment
3CH Y rotation	000-255	Y rotation 0°-270°
4CH Y fine adjustment	000-255	Y fine adjustment
5CH X/Y Speed	000-255	XY speed from fast to slow
6CH Dimmer	000-255	From dark to bright
7CH Strobe	0-5	ON
	6-249	Strobe from slow to fast
	250-255	ON
8CH 7Color + White	0-9	White
	10-180	Colors/ half colors
	181-255	Rainbow Effect(slow to fast)
9CH Focus	000-255	Focus, from near to far
10CH 6 rotation Gobo wheel	0-19	White
	20-39	Gobo 1
	40-59	Gobo 2
	60-79	Gobo 3
	80-99	Gobo 4
	100-119	Gobo 5
	120-139	Gobo 6
	140-255	Gobo rotating CW and CCW from slow to fast)
11CH Gobo self-rotation	0-19	No function
	20-139	Gobo self-rotating clockwise from slow to fast
	140-255	Gobo self-rotating counter-clockwise from slow to fast
12CH Rotation gobo shaking	000-255	Slow-fast
13CH 8 Static Gobos wheel	0-9	White
	10-19	Gobo 1
	20-39	Gobo 2
	40-59	Gobo 3
	60-79	Gobo 4
	80-99	Gobo 5
	100-119	Gobo 6
	120-139	Gobo 7
	140-159	Gobo 8
	160-255	Gobo rotating CW and CCW

		from slow to fast
14CH Static gobo shaking	000-255	Slow-fast
15CH Prism	0-19 20-63 64-255	OFF ON Forward Rotating from fast to slow
16CH Reset	1-199 200-219 220-255	No function Reset after 3 second No function

14-Channel Mode

14 CHS	CH value	Function
1CH X rotation	000-255	X rotation 0°-540°
2CH X fine adjustment	000-255	X fine adjustment
3CH Y rotation	000-255	Y rotation 0°-270°
4CH Y fine adjustment	000-255	Y fine adjustment
5CH X/Y Speed	000-255	XY speed from fast to slow
6CH Dimmer	000-255	From dark to bright
7CH Strobe	0-5 6-249 250-255	ON Strobe from slow to fast ON
8CH 7Color + White	0-9 10-180 181-255	White Colors/ half colors Rainbow Effect(slow to fast)
9CH Focus	000-255	Focus, from near to far
10CH 6 Gobos + White	0-19 20-39 40-59 60-79 80-99 100-119 120-139 140-255	White Gobo 1 Gobo 2 Gobo 3 Gobo 4 Gobo 5 Gobo 6 Gobo rotating CW and CCW from slow to fast)
11CH Gobo self-rotation	0-19 20-139	No function Gobo self-rotating clockwise from slow to fast

	140-255	Gobo self-rotating counter-clockwise from slow to fast
12CH 8 Gobos + White	0-9 10-19 20-39 40-59 60-79 80-99 100-119 120-139 140-159 160-255	White Gobo 1 Gobo 2 Gobo 3 Gobo 4 Gobo 5 Gobo 6 Gobo 7 Gobo 8 Gobo rotating CW and CCW from slow to fast
13CH Prism	0-19 20-63 64-255	OFF ON Forward Rotating from fast to slow
14CH Reset	1-199 200-219 220-255	No function Reset after 3 second No function

11-Channel Mode

11 CHS	CH value	Function
1CH X rotation	000-255	X rotation 0°-540°
2CH Y rotation	000-255	Y rotation 0°-270°
3CH X/Y Speed	000-255	XY speed from fast to slow
4CH Dimmer	000-255	From dark to bright
5CH Strobe	0-5 6-249 250-255	ON Strobe from slow to fast ON
6CH 7Color + White	0-9 10-180 181-255	White Colors/ half colors Rainbow Effect(slow to fast)
7CH Focus	000-255	Focus, from near to far
8CH 6 Gobos + White	0-19 20-39 40-59 60-79 80-99	White Gobo 1 Gobo 2 Gobo 3 Gobo 4

	100-119 120-139 140-255	Gobo 5 Gobo 6 Gobo rotating CW and CCW from slow to fast)
9CH Gobo self-rotation	0-19 20-139 140-255	No function Gobo self-rotating clockwise from slow to fast Gobo self-rotating counter-clockwise from slow to fast
10CH 8 Static Gobos wheel	0-9 10-19 20-39 40-59 60-79 80-99 100-119 120-139 140-159 160-255	White Gobo 1 Gobo 2 Gobo 3 Gobo 4 Gobo 5 Gobo 6 Gobo 7 Gobo 8 Gobo rotating CW and CCW from slow to fast
11CH Prism	0-19 20-63 64-255	OFF ON Forward Rotating from fast to slow

5. APPENDIX

DMX Primer

There are 512 channels in a DMX connection. Channels may be assigned in any manner. A fixture capable of receiving DMX will require one or a number of sequential channels. The user must assign a starting address on the fixture that indicates the first channel reserved in the controller. There are many different types of DMX controllable fixtures and they all may vary in the total number of channels required. Choosing a start address should be planned in advance. Channels should never overlap. If they do, this will result in erratic operation of the fixtures whose starting address is set incorrectly. You can however, control multiple fixtures of the same type using the same starting address as long as the intended result is that of unison movement or

operation. In other words, the fixtures will be slaved together and all respond exactly the same.

DMX fixtures are designed to receive data through a serial Daisy Chain. A Daisy Chain connection is where the DATA OUT of one fixture connects to the DATA IN of the next fixture. The order in which the fixtures are connected is not important and has no effect on how a controller communicates to each fixture. Use an order that provides for the easiest and most direct cabling. Connect fixtures using shielded two conductor twisted pair cable with three pin XLR male to female connectors. The shield connection is pin 1, while pin 2 is Data Negative (S-) and pin 3 is Data positive (S+).

General Maintenance

To maintain optimum performance and minimize wear, fixtures should be cleaned frequently. Usage and environment are contributing factors in determining frequency. As a general rule, fixtures should be cleaned at least twice a month. Dust build up reduces light output performance and can cause overheating. This can lead to reduced lamp life and increased mechanical wear. Be sure to power off fixture before conducting maintenance.

- Unplug fixture from power.
- Use a vacuum or air compressor and a soft brush to remove dust collected on external vents.
- Clean all glass when the fixture is cold with a mild solution of glass cleaner or Isopropyl Alcohol and a soft lint free cotton cloth or lens tissue.
- Apply solution to the cloth or tissue and drag dirt and grime to the outside of the lens.
- Gently polish optical surfaces until they are free of haze and lint.

The cleaning of external optical lenses and/or mirrors must be carried out periodically to optimize light output. Cleaning frequency depends on the environment in which the fixture operates. Damp, smoky or particularly dirty surroundings can cause greater accumulation of dirt on the unit's optics. Clean with soft cloth using normal glass cleaning fluid. Clean the external optics at least every 20 days. Clean the fixture at least every 30/60 days.



Always dry the parts carefully after cleaning them.



Never spin a fan using compressed air.

Fixture Linking

You will need a serial data link to run light shows of one or more fixtures using a DMX controller or to run synchronized shows on two or more fixtures set to a master/slave operating mode. The combined number of channels required by all the fixtures on a serial data link determines the number of fixtures the data link can support.



Fixtures on a serial data link must be daisy chained in one single line. To comply with the EIA485 standard, no more than 32 fixtures should be connected on one data link. Connecting more than 32 fixtures on one serial data link without the use of a DMX optically-isolated splitter may result in deterioration of the digital DMX signal.

Maximum recommended serial data link distance: 500 m (1640 ft)

Maximum recommended number of fixtures on a serial data link: 32

Data Cabling

To link fixtures together you must obtain data cables. You can purchase certified DMX cables directly from a dealer/distributor or construct your own cable. If you choose to create your own cable please use data-grade cables that can carry a high quality signal and are less prone to electromagnetic interference.

DMX Data Cable

Use a Belden© 9841 or equivalent cable which meets the specifications for EIA RS-485 applications. Standard microphone cables cannot transmit DMX data reliably over long distances. The cable must have the following characteristics:

<i>Type:</i>	<i>shielded, 2-conductor twisted pair</i>
<i>Maximum capacitance between conductors:</i>	<i>30 pF/ft</i>
<i>Maximum capacitance between conductor and shield:</i>	<i>55 pF/ft</i>
<i>Maximum resistance:</i>	<i>20 ohms/1000 ft</i>
<i>Nominal impedance:</i>	<i>100 ~ 140 ohms</i>

Cable Connectors

Cabling must have a male XLR connector on one end and a female XLR connector on the other end.

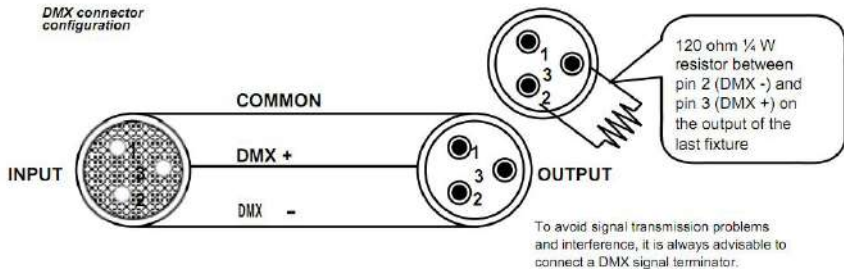

Do not allow contact between the common and the fixture's chassis ground. Grounding the common can cause a ground loop, and your fixture may perform erratically. Test cables with an ohm meter to verify correct polarity and to make sure the pins are not grounded or shorted to the shield or each other.

3-Pin to 5-Pin Conversion Chart



if you use a controller with a 5-pin DMX output connector, you will need to use a 5pin to 3-pin adapter. The chart below details a proper cable conversion:

3-PIN TO 5-PIN CONVERSION CHART

3-PIN TO 5-PIN CONVERSION CHART

Conductor	3-Pin Female (Output)	5-Pin Male (Input)
Ground/Shield	Pin 1	Pin 1
Data (-) signal	Pin 2	Pin 2
Data (+) signal	Pin 3	Pin 3
Not used		Pin 4
Not used		Pin 5

Setting up a DMX Serial Data Link

Universal DMX

Controller

1. Connect the (male) 3-pin connector side of the DMX cable to the output (female) 3-pin connector of the controller.
2. Connect the end of the cable coming from the controller which will have a (female) 3-pin connector to the input connector of the next fixture consisting of a (male) 3-pin connector.
3. Then, proceed to connect from the output as stated above to the input of the following fixture and so on.

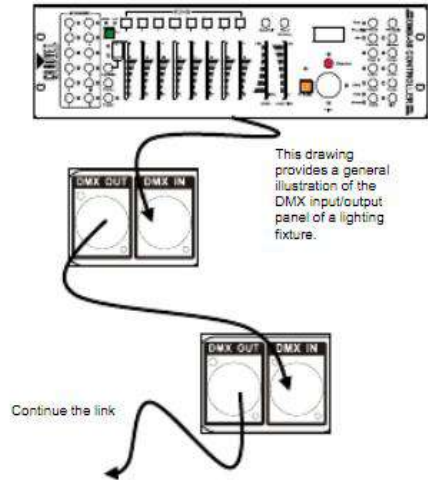

Setting the Starting Address

This DMX mode enables the use of a universal DMX controller device. Each fixture requires a start address from 1~512. A fixture requiring one or more channels for control begins to read the data on the channel indicated by the start address. For example, a fixture that uses six DMX channels and was addressed to start on DMX channel 100, would read data from channels: 100, 101, 102, 103, 104, and 105. Choose start addresses so that the channels used do not overlap, and note the start address selected for future reference.

If this is your first time addressing a fixture using the DMX control protocol, we suggest jumping to the “Appendix” section and reading the heading “DMX Primer”. It contains very useful information that will help you understand its use.

General Troubleshooting

SYMPTOM	POSSIBLE CAUSE(S)	POSSIBLE ACTION(S)
Breaker/Fuse keeps blowing	<ul style="list-style-type: none"> • Excessive circuit load • Short circuit along the power wires 	<ul style="list-style-type: none"> • Check total load placed on the electrical circuit. • Check for a short in the electrical wiring (internal and/or external)
Device does not power up	<ul style="list-style-type: none"> • No power • Loose power cord 	<ul style="list-style-type: none"> • Check for power on power outlet • Check power cord
Fixture is not responding to DMX	<ul style="list-style-type: none"> • Wrong DMX addressing • Damaged DMX cables • Wrong polarity settings on the controller • Loose DMX cables • Faulty DMX interface • Faulty Main PCB 	<ul style="list-style-type: none"> • Check Control Panel and unit addressing • Check DMX cables • Check polarity switch settings on the controller • Check cable connections • Replace DMX input • Replace Main PCB
Loss of signal	<ul style="list-style-type: none"> • Non DMX cables • Bouncing signals • Long cable / Low level signal • Too many fixtures • Interference from AC wires 	<ul style="list-style-type: none"> • Use only DMX compatible cables • Install terminator as suggested • Install amplifier right after fixture with strong signal • Install an optically coupled DMX splitter after unit #32 • Keep DMX cables separated from power cables or black lights