

# 150W BEAM,SPOT,WASH 3 IN 1 LED MOVING HEAD

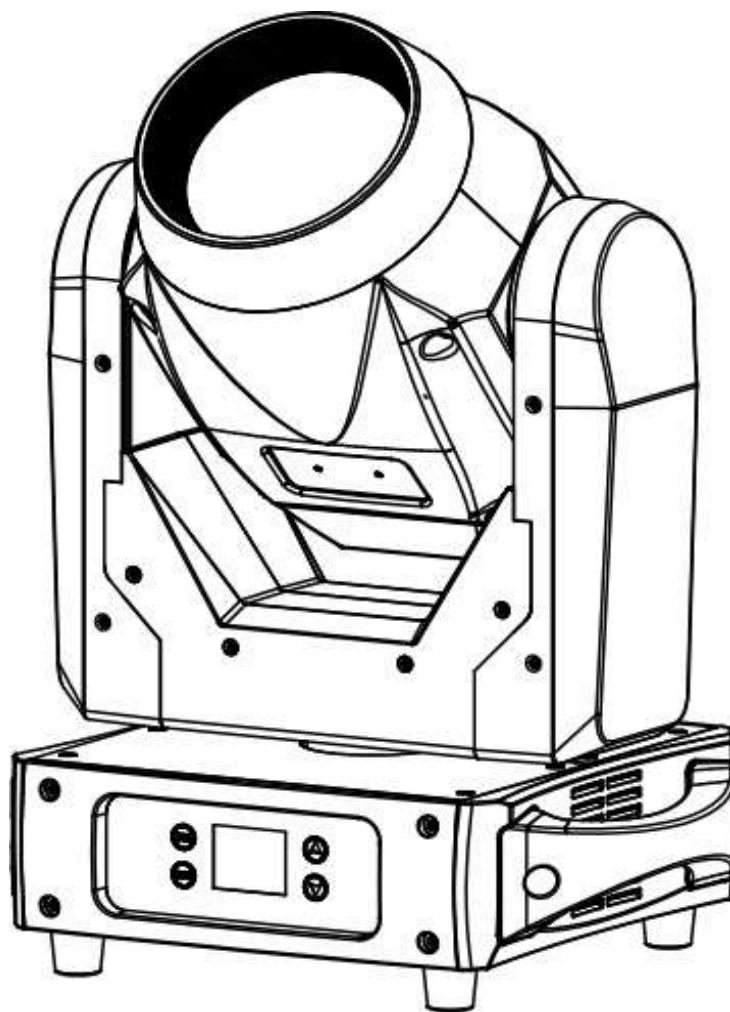

## **User Manual**

Please read the instruction carefully before use

## CONTENTS

1. Safety Instructions.....	2
2. Technical Specifications.....	4
3. Description.....	5
3.1 Control Panel.....	5
4. Gobo and Lamp.....	6
4.1 Gobos.....	6
5. How To Set The Unit.....	7
5.1 Main Function.....	7
5.2 Home Position Adjustment.....	14
5.3 Error Information.....	16
6. Control By Universal DMX Controller.....	17
6.1 Connection.....	17
6.2 Address Setting.....	18
6.3 DMX 512 Configuration.....	18
7. Troubleshooting.....	26
8. Cleaning.....	27

## 1. Safety Instructions

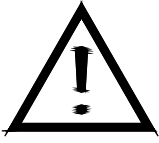

Please read the instruction carefully which includes important information about the installation, usage and maintenance.

### WARNING

Please keep this User Guide for future consultation. If you sell the unit to another user, be sure that they also receive this instruction manual.

#### ***Important:***

***Damages caused by the disregard of this user manual are not subject to warranty. The dealer will not accept liability for any resulting defects or problems.***

- Unpack and check carefully that there is no transportation damage before using the unit.
- The unit is for indoor use only. Use only in a dry location.
- DO install and operate by qualified operator.
- DO NOT allow children to operate the fixture.
- Use safety chain when fixing the unit. Handle the unit by carrying its base instead of head only.
- The unit must be installed in a location with adequate ventilation, at least 50cm from adjacent surfaces.
- Be sure that no ventilation slots are blocked, otherwise the unit will be overheated.
- Before operating, ensure that the voltage and frequency of power supply match the power requirements of the unit.
- It's important to ground the yellow/green conductor to earth in order to avoid electric shock.
- Maximum ambient temperature TA: 40°C. DO NOT operate it when the temperature is higher.
- DO NOT connect the device to any dimmer pack.
- During initial start-up some smoke or smell may arise. This is a normal process and does not necessarily mean that the device is defective, and it will decrease gradually within 15 minutes.
- Make sure there are no flammable materials close to the unit while operating to avoid fire hazard.
- Examine the power wires carefully; replace them immediately if there is any damage.
- Unit's surface temperature may reach up to 85°C. DO NOT touch the housing bare-handed during its operation, and allow about 15 minutes for cooling the unit down before replacing bulb or maintenance as it could be very hot.
- Avoid any inflammable liquids, water or metal objects entering the unit. Once it happens, cut off

the mains power immediately.

- DO NOT operate in dirty or dusty environment, do clean fixtures regularly.
- DO NOT touch any wire during operation as there might be a hazard of electric shock.
- Avoid power wires together twist other cables.
- The minimum distance between light output and the illuminated surface must be more than 12 meters.
- Disconnect mains power before fuse/lamp replacement or servicing.
- Replace fuse/lamp only with the same type.
- In the event of serious operating problem, stop using the unit immediately.
- Never turn on and off the unit time after time.
- The housing, the lenses, or the ultraviolet filter must be replaced if they are visibly damaged.
- DO NOT open the unit as there are no user serviceable parts inside.
- Never try to repair the unit by yourself. Repairs carried out by unskilled people can lead to damage or malfunction. Please contact the nearest authorized technical assistance center if needed.
- Disconnect the mains power if the fixture is has not been used for a long time.
- DO use the original packing materials before transporting it again.

### **Cautions:**

- To prevent or reduce the risk of electrical shock or fire, do not expose the unit to rain or moisture.
- Hot lamp explosion hazard. DO NOT open the unit within 15 minutes after switching off.
- DO replace the bulb once it is damaged, deformed or life-expired.
- DO NOT look directly at the light while the bulb is on.
- Never touch bulb with bare fingers, as it is very hot after using.
- DO NOT start on the unit without bulb enclosure or when housing is damaged.

### **Installation:**

The unit is fully operational in three different mounting positions, hanging upside-down from a ceiling or set on a flat level surface. To avoid internal damage to the unit, never mount the unit on its side as illustrated above. Be sure this fixture is kept at least 0.5m away from any flammable materials (decoration etc.). Always use and install the supplied safety cable as a safety measure to prevent accidental damage and/or injury in the event the clamp fails.

## 2. Technical Specifications

### Power supply

- AC 100~240V 50/60Hz

### Power Consumption

- 150W

### Light Source

- 1 X 230W LED

### Angle

- Beam Angle: 11° (on full open)
  - 2°/4°/6°/8°/10° (with beam reducer)
  - 3°/6°/9°/12°/15°/20° (with zoom lens)
- Spot Angle: Fix Gobo: 2° → 15° (with zoom lens)
  - Rotating Gobo: 10° → 17° (with zoom lens)
- Wash Angle: 15° → 28°

### Movement

- Pan: 540°
- Tilt: 270°
- Pan/Tilt moving speed adjustable.
- Automatic Pan/Tilt correction.
- Easy calibration and maintenance by magnetic home positioning.

### Dimmer/Shutter

- Blackout, 0~100% smooth dimming, independent shutter and various strobe effect.
- Integrated three features: beam, spot and wash

### Color wheel

- 8 fixed colors plus white
- Rainbow effect in both directions.

### Gobo wheel

- 1 Static gobo wheel with 7 gobos plus open
- 1 Rotating gobo wheel with 6 gobos plus open

### Prism

- Prism : 3 facet prism rotating in both directions

**Frost**

- Independent frost effect

**Focus**

- Motorized focus

**Zoom**

- Motorized linear zoom system

**Protocols**

- DMX 512
- Date input/output: 3/5 Pin XLR socket

**Weight**

- 12 Kg

**Dimension**

- 452× 290×256mm

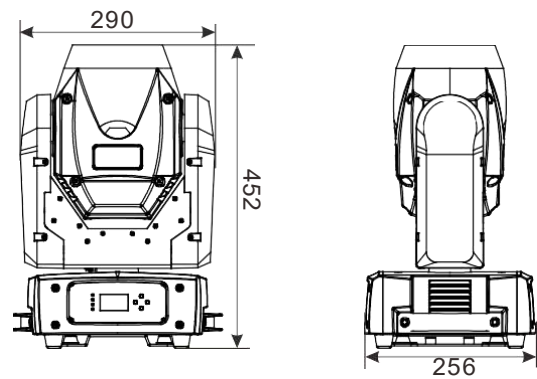

**3. Description**

**3.1 Control Panel**

**Front view**

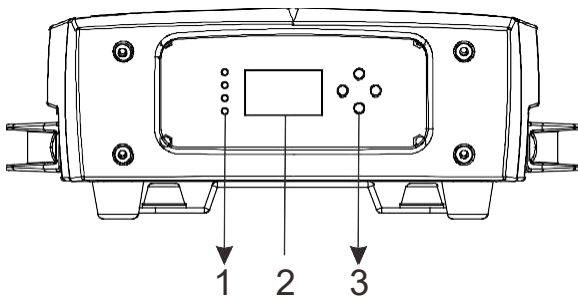

**Rear view**

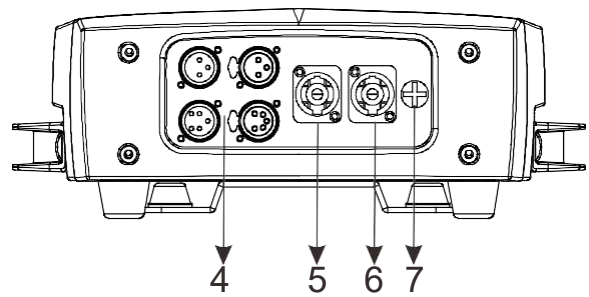

**1. LED:**

<b>MASTER</b>	On	Master mode
<b>SLAVE</b>	On	Slave mode
<b>SOUND</b>	On	Sound activation
<b>DMX</b>	On	DMX input present

**2. Display:** To show the various menus and the selected function.

**3. Button:**

<b>MENU</b>	To enter into move backward or leave the menu
<b>UP</b>	To go backward to move up in the menu
<b>DOWN</b>	To go to move down in the menu
<b>ENTER</b>	To perform the desired functions

**4. DMX input/output:** For DMX 512 operation, use 3/5-pin XLR plug cable to link the units together

**5. Power In:** Used to connect to supply power.

**6. Power out:** Used to connect to next unit.

**7. Fuse (T 5A):** Protect the unit from damage of over current.

## Gobo and Lamp

### Gobos

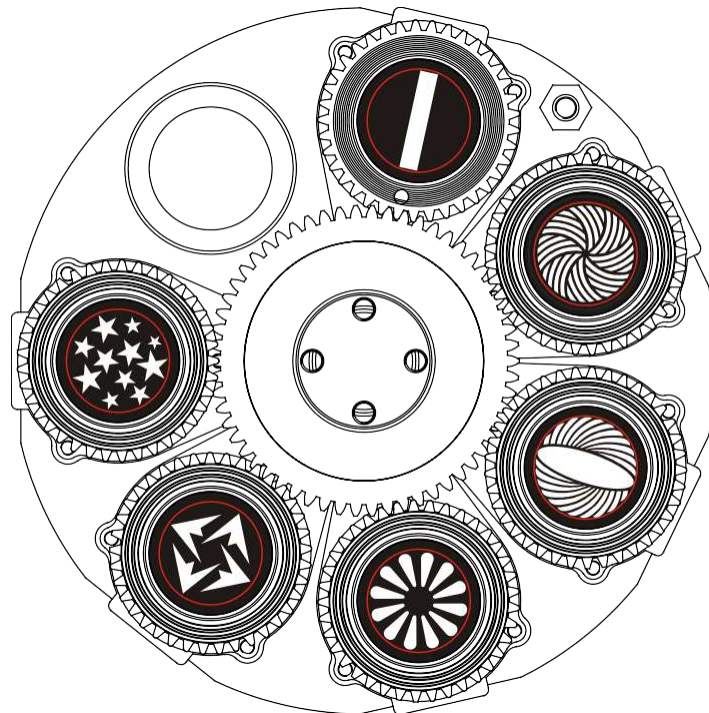

#### ***DANGER!***

***Install the gobos with the device switched off only.  
Unplug from mains before changing gobos!***

***CAUTION: Never unscrew the screws of the rotating gobo as the ball bearing will otherwise be opened!***

## How To Set The Unit

### Main Function

Turn on the unit, press the **MENU** button into menu mode, and press the **UP/DOWN** button until the required function is shown on the monitor. Select the function by the **ENTER** button. Use the **UP/DOWN** button to choose the submenu, press the **ENTER** button to store and automatically return to the last menu. Press the **MENU** button or let the unit idle one minute to exit menu mode.

In the event of disconnecting with mains power, press the **UP** button for one minute to enter into menu mode. Press **MENU** button or let the unit idle one minute to exit.

The main functions are shown below (the grayed boxes are preset settings) :



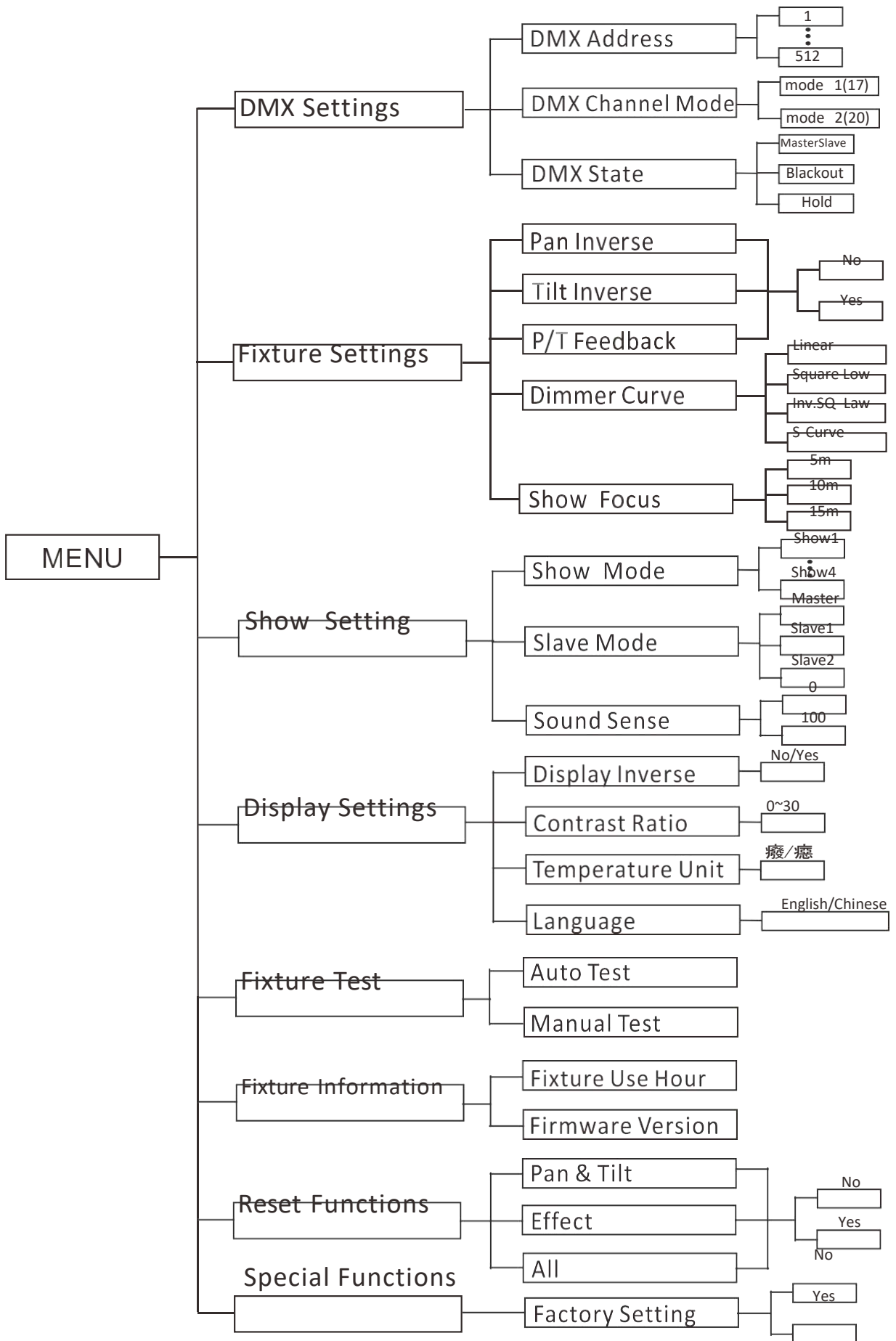

## ***DMX Settings***

To select ***DMX Settings*** press the **ENTER** button to confirm, use the **UP/DOWN** button to select ***DMX Address, DMX Channel Mode*** or ***DMX State***.

### **DMX Address** —DMX512 address setting

To select **DMX Address**, press the **ENTER** button to confirm. Use the **UP/DOWN** button to adjust the address from **001** to **512**, press the **ENTER** button to store. Press the **MENU** button back to the last menu or let the unit idle one minute to exit menu mode.

### **DMX Channel Mode** — channel mode

To select **DMX Channel Mode**, press the **ENTER** button to confirm. Use the **UP/DOWN** button to select **Mode1 (17)** or **Mode2 (20)** channels mode, press the **ENTER** button to store. Press the **MENU** button back to the last menu or let the unit idle one minute to exit menu mode.

### **DMX State** — fixture state while DMX single stops

To select **DMX State**, press the **ENTER** button to confirm. Use the **UP/DOWN** button to select **Master Slave**(fixture enters to master slave mode),**Blackout** (fixture blacks out if DMX signal stops) or **Hold** (fixture continues to obey the last command it received Via DMX if DMX signal stops), press the **ENTER** button to store. Press the **MENU** button back to the last menu or let the unit idle one minute to exit menu mode.

## ***Fixture Settings***

To select ***Fixture Settings***, press the **ENTER** button to confirm, use the **UP/DOWN** button to select ***Pan Inverse, Tile Inverse, P/T Feedback, Dimmer Curve*** or ***Show Focus***.

### **Pan Inverse**

To select **Pan Inverse**, press the **ENTER** button to confirm. Use the **UP/DOWN** button to select **No** (normal) or **Yes** (pan inverse), press the **ENTER** button to store. Press the **MENU** button back to the last menu or let the unit idle one minute to exit menu mode.

### **Tilt Inverse**

To select **Tilt Inverse**, press the **ENTER** button to confirm. Use the **UP/DOWN** button to select **No** (normal) or **Yes** (tilt inverse), press the **ENTER** button to store. Press the **MENU** button back to the last menu or let the unit idle one minute to exit menu mode.

### **P/T Feedback**

To select **P/T Feedback**, press the **ENTER** button to confirm. Use the **UP/DOWN** button to select

**No** (Pan or tilt's position will not feedback while out of step) or **Yes** (Feedback while pan/tilt out of step), press the **ENTER** button to store. Press the **MENU** button back to the last menu or let the unit idle one minute to exit menu mode.

### Dimmer Curve

To select **Dimmer Curve**, press the **ENTER** button to show the **DIMMER CURVE** on the display. Use the **DOWN/UP** button to select the **Mode1** or **Mode 2** or **Mode 3** or **Mode 4**. Once the mode has been selected, press the **ENTER** button to setup, to go back to the functions without any change press the **MENU** button again. Press and hold the **MENU** button about one second or wait for one minute to exit the menu mode.

### Dimmer Modes

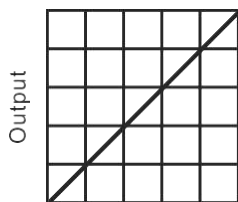

Optically Linear

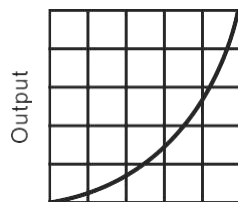

Square Law

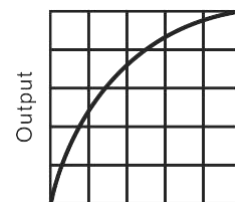

Inverse Square Law

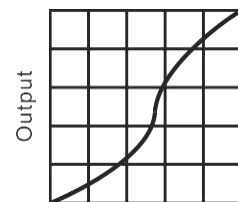

S-curve

#### **Mode 1(Optically Linear):**

The increase in light intensity appears to be linear as DMX value is increased.

#### **Mode 2(Square Law):**

Light intensity control is finer at low levels and coarser at high levels.

#### **Mode 3(Inverse Square Law):**

Light intensity control is coarser at low levels and finer at high levels.

#### **Mode 4(S-cure):**

Light intensity control is finer at low levels and high levels and coarser at medium levels.

### Show Focus

To select **Show Focus**, press the **ENTER** button to confirm. Use the **UP/DOWN** button to select **5m,10m** or **15m**, press the **ENTER** button to store. Press the **MENU** button back to the last menu or let the unit idle one minute to exit menu mode.

### Show Setting

To select **Show Setting**, press the **ENTER** button to confirm, use the **UP/DOWN** button to select **Show Mode, Slave Mode** or **Sound Sense**.

### **Show Mode**

To select **Show Mode**, press the **ENTER** button to confirm. Use the **UP/DOWN** button to select **show1, show 2, show 3** or **show 4**, press the **ENTER** button to store. Press the **MENU** button back to the last menu or let the unit idle one minute to exit menu mode.

### **Slave Mode**

To select **Slave Mode**, press the **ENTER** button to confirm. Use the **UP/DOWN** button to select **master, slave 1** or **slave 2**, press the **ENTER** button to store. Press the **MENU** button back to the last menu or let the unit idle one minute to exit menu mode.

### **Sound Sense**

To select **Sound Sense**, press the **ENTER** button to confirm. Use the **UP/DOWN** button to adjust the value from **0** to **100**, press the **ENTER** button to store. Press the **MENU** button back to the last menu or let the unit idle one minute to exit menu mode.

## **Display Settings**

Enter menu mode, select **Display Setting**, press the **ENTER** button to confirm, use the **UP/DOWN** button to select **Display Inverse, Contrast Ratio, Temperature Unit** or **Language**.

### **Display Inverse**

Select **Display Inverse**, press the **ENTER** button to confirm, present mode will blink on the display, use the **UP/DOWN** button to select **No** (normal display) or **Yes** (inverse display), press the **ENTER** button to store. Press the **MENU** button back to the last menu or let the unit idle one minute to exit menu mode.

### **Contrast Ratio**

Select **Contrast Ratio**, press the **ENTER** button to confirm, present mode will blink on the display, use the **UP/DOWN** button to adjust value from **0** to **30**, press the **ENTER** button to store. Press the **MENU** button back to the last menu or let the unit idle one minute to exit menu mode.

### **Temperature Unit**

Select **Temperature Unit**, press the **ENTER** button to confirm, present mode will blink on the display, use the **UP/DOWN** button to select **°C** or **°F**, press the **ENTER** button to store. Press the **MENU** button back to the last menu or let the unit idle one minute to exit menu mode.

### **Language**

Select **Language**, press the **ENTER** button to confirm, present mode will blink on the display, use the **UP/DOWN** button to select **English** or **Chinese**. Press the **MENU** button back to the last menu

or let the unit idle one minute to exit menu mode.

## ***Fixture Test***

Enter menu mode, select ***Fixture Test***, press the **ENTER** button to confirm, use the **UP/DOWN** button to select ***Auto Test*** or ***Manual Test***

### **Auto Test**

Select **Auto Test**, press the **ENTER** button to confirm, the unit will run built-in programs to automatically test pan, tilt, shutter, color, CMY, gobo, gobo rotation, prism, prism rotation, iris, frost, zoom, focus, dimmer and lamp on/off. Press the **MENU** button back to the last menu or exit menu mode after auto test.

### **Manual Test**

Select **Manual Test**, press the **ENTER** button to confirm, the present channel will show on the display, use the **UP/DOWN** button to select channel, press the **ENTER** button to confirm, then use the **UP** and **DOWN** button to adjust the value, press the **ENTER** button to store, the fixture will run as the channel value indicates. Press the **MENU** button back to the last menu or exit menu mode idling one minute.

*(All channels value will become 0 after exiting Manual Test menu)*

## ***Fixture Information***

Enter menu mode, select ***Fixture Information***, press the **ENTER** button to confirm, use the **UP/DOWN** button to select ***Fixture use time*** or ***Firmware Version***.

### **Fixture use hour**

Select **Fixture use hour**, press the **ENTER** button to confirm, fixture use time will show on the display, press the **MENU** button to exit.

### **Firmware Version**

Select **Firmware Version**, press the **ENTER** button to confirm, firmware version will show on the display, press the **MENU** button back to exit.

## ***Reset Functions***

Enter menu mode, select ***Reset Function***, press the **ENTER** button to confirm, use the **UP/DOWN** button to select ***Pan/Tilt, Effect*** or ***All***.

**Pan & Tilt** —Reset Pan/Tilt

Select **Pan & Tilt**, press the **ENTER** button to confirm, use the **UP/DOWN** button to select **Yes** (the unit will run built-in program to reset pan and tilt to their home positions) or **No**(normal), press the **ENTER** button to store. Press the **MENU** button back to the last menu or let the unit idle one minute to exit menu mode.

#### **Effect — Reset Effect**

Select **Effect**, press the **ENTER** button to confirm, use the **UP/DOWN** button to select **Yes** (the unit will run built-in program to reset effect to their home positions) or **No**, press the **ENTER** button to store. Press the **MENU** button back to the last menu or let the unit idle one minute to exit menu mode

#### **All — Reset All**

Select **All**, press the **ENTER** button to confirm, use the **UP/DOWN** button to select **Yes** (the unit will run built-in program to reset all motors to their home positions) or **No**, press **ENTER** button to store. Press the **MENU** button to exit.

### ***Special Functions***

#### **Factory Settings**

Select **Factory Settings**, press the **ENTER** button to confirm, use the **UP/DOWN** button to select **Yes** (the fixture will reset to factory settings) or **No** (normal), press **ENTER** button to store. Press the **MENU** button to exit.

## 5.2 Home Position Adjustment

Press the **MENU** button into menu mode, then press the **ENTER** button for about 3 seconds into offset mode to adjust the home position. Select the function by the **ENTER** button. Use the **UP/DOWN** button to choose the submenu, press the **ENTER** button to store and automatically return to the last menu. Press **MENU** button to exit.

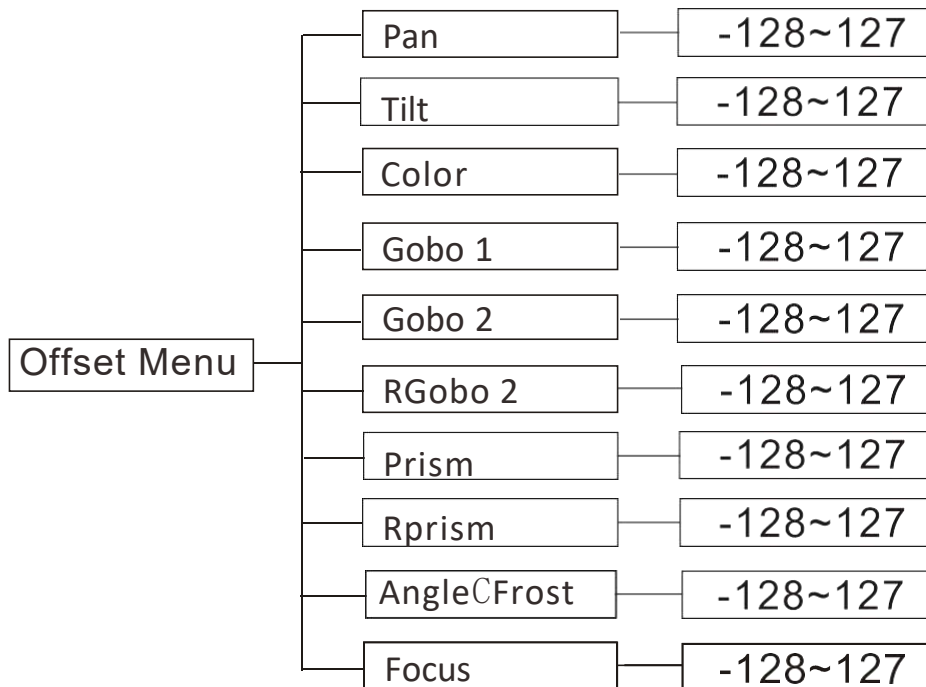

### **Pan**—pan home position adjustment

Enter offset mode, Select **Pan**, press the **ENTER** button to confirm, the present position will blink on the display, use the **UP/DOWN** button to offset the value from -128 to 127, press the **ENTER** button to store. Press the **MENU** button to exit.

### **Tilt**—Tilt home position adjustment

Enter offset mode, Select **Tilt**, press the **ENTER** button to confirm, the present position will blink on the display, use the **UP/DOWN** button to offset the value from -128 to 127, press the **ENTER** button to store. Press the **MENU** button to exit.

### **Color 1**—Color 1 home position adjustment

Enter offset mode, Select **Color 1**, press the **ENTER** button to confirm, the present position will blink on the display, use the **UP/DOWN** button to offset the value from -128 to 127, press the **ENTER** button to store. Press the **MENU** button to exit.

### **Gobo 1**—Gobo 1 home position adjustment

Enter offset mode, Select **Gobo 1**, press the **ENTER** button to confirm, the present position will blink on the display, use the **UP/DOWN** button to offset the value from -128 to 127, press the **ENTER** button to store. Press the **MENU** button to exit.

**Gobo 2**—Gobo 2 home position adjustment

Enter offset mode, Select **Gobo 2**, press the **ENTER** button to confirm, the present position will blink on the display, use the **UP/DOWN** button to offset the value from -128 to 127, press the **ENTER** button to store. Press the **MENU** button to exit.

**R-Gobo 2**—Gobo 2 rotation home position adjustment

Enter offset mode, Select **R-Gobo 2**, press the **ENTER** button to confirm, the present position will blink on the display, use the **UP/DOWN** button to offset the value from -128 to 127, press the **ENTER** button to store. Press the **MENU** button to exit.

**Prism**—Prism home position adjustment

Enter offset mode, Select **Prism**, press the **ENTER** button to confirm, the present position will blink on the display, use the **UP/DOWN** button to offset the value from -128 to 127, press the **ENTER** button to store. Press the **MENU** button to exit.

**R-Prism**—Prism rotation home position adjustment

Enter offset mode, Select **R-Prism**, press the **ENTER** button to confirm, the present position will blink on the display, use the **UP/DOWN** button to offset the value from -128 to 127, press the **ENTER** button to store. Press the **MENU** button to exit.

**Beam/Frost**—Beam/Frost home position adjustment

Enter offset mode, Select **Beam/Frost**, press the **ENTER** button to confirm, the present position will blink on the display, use the **UP/DOWN** button to offset the value from -128 to 127, press the **ENTER** button to store. Press the **MENU** button to exit.

**Focus**—Focus home position adjustment

Enter offset mode, Select **Focus**, press the **ENTER** button to confirm, the present position will blink on the display, use the **UP/DOWN** button to offset the value from -128 to 127, press the **ENTER** button to store. Press the **MENU** button to exit.



## **5.3 Error Information**

### **Lamp Startup Fail**

It appears when there is no lamp or some wires are damaged.

### **Temperature Sense Error**

It appears when temperature check board is damaged.

### **Lamp Too Hot Power Off**

It appears when temperature is detected higher than 110°C. Check if the unit is properly ventilated, or fans or temperature check board may be damaged.

### **Lamp Too Hot Low Power**

It appears when detected temperature is higher than 105°C. The unit will run on a low power level.

### **Lamp On Over 700 Hour**

It appears when the lamp has always been on over 700 hours, please turn off the lamp.

### **Memory Initial Fail**

It appears when the memory IC is damaged.

### **CPU-B Error, CPU-C Error, CPU-D Error**

They appear when board P.C or some wires are damaged.

### **Pan Reset Error, Pan Encode Error, Tilt Reset Error, Tilt Encode Error, Shutter Reset Fail, Dimmer Reset Fail, Color Reset Fail, Cyan Reset Fail, Magenta Reset Fail, Yellow Reset Fail, Gobo1 Reset Fail, R-Gobo1 Reset Fail, Gobo2 Reset Fail, Iris Reset Fail, Effect Reset Fail, R-Effect Reset Fail, Frost Reset Fail, Flat Reset Fail, Focus Reset Fail, Zoom Reset Fail**

They may appear when turning on or resetting the unit, for some parts such as board P.C are damaged. Please contact the qualified maintenance.

## 6. Control By Universal DMX Controller

### 6.1 Connection

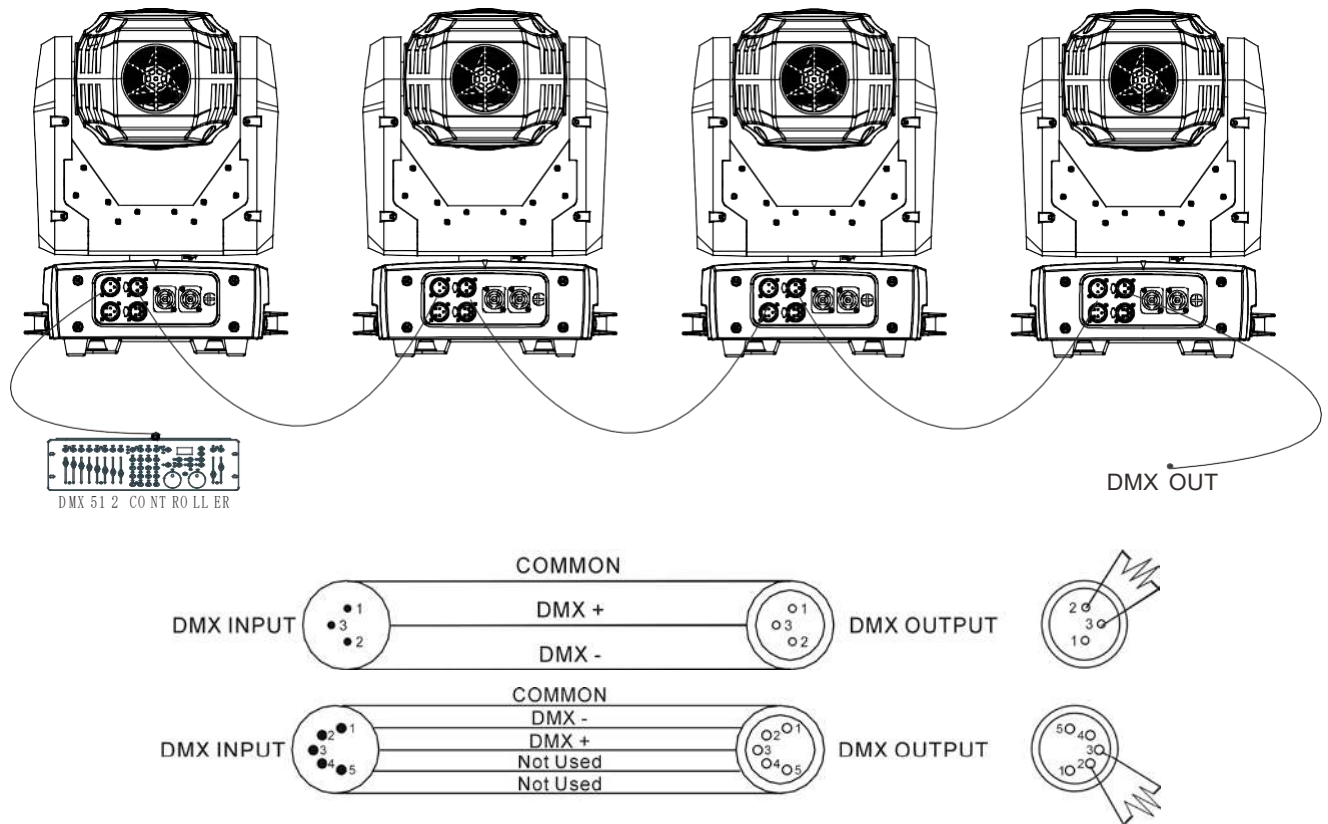

#### ATTENTION

Termination reduces signal errors and to avoid signal transmission problems and interference. It is always advisable to connect a DMX terminal (Resistance 120 ohm 1/4W between pin2 (DMX-) and pin3 (DMX+) of the last fixture).

1. At last unit, the DMX cable has to be terminated with a terminator. Solder a 120-ohm 1/4W resistor between pin 2(DMX-) and pin 3(DMX+) into a 3-pin XLR-plug and plug it in the DMX-output of the last unit.
2. Connect the unit together in a “daisy chain” by XLR plug cable from the output of the unit to the input of the next unit. The cable cannot be branched or split to a “Y” cable. DMX 512 is a very high-speed signal. Inadequate or damaged cables, soldered joints or corroded connectors can easily distort the signal and shut down the system.
3. The DMX output and input connectors are pass-through to maintain the DMX circuit, when one of the units’ power is disconnected.
4. Each lighting unit needs to have a DMX address to receive the data by the controller. The address

number is between 0-511 (usually 0 & 1 are equal to 1).

5. The end of the DMX 512 system should be terminated to reduce signal errors.

6. 3 pin XLR connectors are more popular than 5 pins XLR.

3 pin XLR: Pin 1: GND, Pin 2: Negative signal (-), Pin 3: Positive signal (+)

5 pin XLR: Pin 1: GND, Pin 2: Negative signal (-), Pin 3: Positive signal (+), Pin4, Pin5 not used.

## 6.2 Address Setting

If you use a universal DMX controller to control the units, you have to set DMX address from 1 to 512 so that the units can receive DMX signal.

Press the **MENU** button to enter menu mode, select **DMX Functions**, press the **ENTER** button to confirm, use the **UP/DOWN** button to select **DMX Address**, press the **ENTER** button to confirm, the present address will blinking the display, use the **UP/DOWN** button to adjust the address from 001 to 512, press the **ENTER** button to store. Press the **MENU** button back to the last menu or idling let the unit idle one minute to exit menu mode.

Please refer to the following diagram to address your DMX512 channel for the first 4 units.

Channel mode	Unit 1 Address	Unit 2 Address	Unit 3 Address	Unit 4 Address
17 channels	1	18	35	52
20 channels	1	21	41	61

## 6.3 DMX 512 Configuration

Please refer to below configurations to control the fixtures

### Attentions:

1. The unit will maintain the last condition until reset if you cut-off the DMX signal.
2. For the channel Function, keep the value for about 5 seconds, then the corresponding function will take into effect.

### 17 Channels (Mode 1):

CHANNEL	VALUE	FUNCTION
1	000-255	PAN 0° → 540°

<b>2</b>	000-255	<b>TILT</b> 0° → 270°
<b>3</b>	000-255	<b>PAN/TILT SPEED</b> Fast to Slow
<b>4</b>	000-015 016-063 064-127 128-191 192-255	<b>SHOW MODE</b> Null Show 1 Show 2 Show 3 Show 4
<b>5</b>	000-007 008-015 016-023 024-031 032-039 040-047 048-055 056-063 064-071 072-079 080-087 088-095 096-103 104-111 112-119 120-127 128-135 136-143 144-151 152-159 160-167 168-175 176-183 184-191 192-199 200-207 208-215 216-223 224-231 232-239	<b>PAN/TILT MACRO</b> Off Macro 1 Macro 2 Macro 3 Macro 4 Macro 5 Macro 6 Macro 7 Macro 8 Macro 9 Macro 10 Macro 11 Macro 12 Macro 13 Macro 14 Macro 15 Macro 16 Macro 17 Macro 18 Macro 19 Macro 20 Macro 21 Macro 22 Macro 23 Macro 24 Macro 25 Macro 26 Macro 27 Macro 28 Macro 29

	240-247 248-255	Macro 30 Macro 31
<b>6</b>	000-255	<b>MACRO SPEED</b> fast to slow
<b>7</b>	000-015 016-018 019-021 022-024 025-027 028-030 031-033 034-036 037-039 040-042 043-045 046-048 049-051 052-054 055-057 058-060 061-063 064-127 128-189 190-192 193-255	<b>COLOR</b> White Color1 Color2 Color3 Color4 Color5 Color6 Color7 Color8 Color9 Color10 Color11 Color12 Color13 Color14 Color15 Color16 Color wheel indexing Counter-Clockwise rotation, fast to slow Stop Clockwise rotation, slow to fast
<b>8</b>	000-007 008-015 016-023 024-031 032-039 040-047 048-055 056-063 064-127 128-190 191-192 193-255	<b>GOBO WHEEL 1</b> Open Gobo1-1 Gobo1-2 Gobo1-3 Gobo1-4 Gobo1-5 Gobo1-6 Gobo1-7 Gobo1 1-7 shaking Counter-Clockwise rotation, fast to slow Stop Clockwise rotation, slow to fast
<b>9</b>	000-008	<b>GOBO WHEEL 2</b> Open

	009-017 018-026 027-035 036-044 045-053 054-063 064-127 128-190 191-192 193-255	Gobo2-1 Gobo2-2 Gobo2-3 Gobo2-4 Gobo2-5 Gobo2-6 Gobo2 1 -6 Shaking Counter-Clockwise rotation, fast to slow Stop Clockwise rotation, slow to fast
<b>10</b>	000-127 128~190 191-192 193-255	<b>R-GOBO 2</b> Index clockwise rotation fast to slow Stop Counter-clockwise rotation slow to fast
<b>11</b>	000-063 064-127 128-255	<b>ANGLE/FROST</b> Off Angle Frost
<b>12</b>	000-009 010-255	<b>PRISM</b> No effect Prism Effect
<b>13</b>	000-127 128-190 191-192 193-255	<b>R-PRISM</b> Index Counter-clockwise rotation fast to slow Stop clockwise rotation slow to fast
<b>14</b>	000-255	<b>FOCUS</b> 0% → 100%
<b>15</b>	000-007 008-015 016-131 132-139 140-181 182-189 190-231 232-239 240-247 248-255	<b>SHUTTER</b> Off On slow to fast strobe open Slow open fast close open Slow close fast open open Random strobe Open
<b>16</b>		<b>DIMMER</b>

	000-255	0% → 100%
<b>17</b>		<b>SPECIAL FUNCTION</b>
	000-069	No function
	070-079	Enable blackout while Pan/Tilt Moving
	080-089	Disable blackout while Pan/Tilt Moving
	090-099	Enable blackout while Color changing
	100-109	Disable blackout while Color changing
	110-119	Enable blackout while Gobo changing
	120-129	Disable blackout while Gobo changing
	130-139	No function
	140-149	Pan/Tilt reset
	150-159	Effect reset
	160-199	No function
	200-209	All reset
	210-219	Enable blackout while Pan/Tilt Color Gobo Moving
220-229	Disable blackout while Pan/Tilt Color Gobo Moving	
230-255	No function	

**20 Channels (Mode 2):**

CHANNEL	VALUE	FUNCTION
<b>1</b>	000-255	<b>PAN</b>
		0° → 540°
<b>2</b>	000-255	<b>PAN FINE</b>
<b>3</b>	000-255	<b>TILT</b>
		0° → 270°
<b>4</b>	000-255	<b>TILT FINE</b>
<b>5</b>	000-255	<b>PAN/TILT SPEED</b>
		Fast to Slow
<b>6</b>	000-015 016-063 064-127 128-191 192-255	<b>SHOW MODE</b>
		Null
		Show 1
		Show 2
		Show 3
		Show 4
<b>7</b>	000-007 008-015 016-023 024-031	<b>PAN/TILT MACRO</b>
		Off
		Macro 1
		Macro 2
		Macro 3

	032-039 040-047 048-055 056-063 064-071 072-079 080-087 088-095 096-103 104-111 112-119 120-127 128-135 136-143 144-151 152-159 160-167 168-175 176-183 184-191 192-199 200-207 208-215 216-223 224-231 232-239 240-247 248-255	Macro 4 Macro 5 Macro 6 Macro 7 Macro 8 Macro 9 Macro 10 Macro 11 Macro 12 Macro 13 Macro 14 Macro 15 Macro 16 Macro 17 Macro 18 Macro 19 Macro 20 Macro 21 Macro 22 Macro 23 Macro 24 Macro 25 Macro 26 Macro 27 Macro 28 Macro 29 Macro 30 Macro 31
<b>8</b>	000-255	<b>MACRO SPEED</b> fast to slow
<b>9</b>	000-015 016-018 019-021 022-024 025-027 028-030 031-033 034-036 037-039 040-042	<b>COLOR</b> White Color1 Color2 Color3 Color4 Color5 Color6 Color7 Color8 Color9



	043-045 046-048 049-051 052-054 055-057 058-060 061-063 064-127 128-189 190-192 193-255	Color10 Color11 Color12 Color13 Color14 Color15 Color16 Color wheel indexing Counter-Clockwise rotation, fast to slow Stop Clockwise rotation, slow to fast
<b>10</b>	000-007 008-015 016-023 024-031 032-039 040-047 048-055 056-063 064-127 128-190 191-192 193-255	<b>GOBO WHEEL 1</b> Open Gobo1-1 Gobo1-2 Gobo1-3 Gobo1-4 Gobo1-5 Gobo1-6 Gobo1-7 Gobo1 1-7 shaking Counter-Clockwise rotation, fast to slow Stop Clockwise rotation, slow to fast
<b>11</b>	000-008 009-017 018-026 027-035 036-044 045-053 054-063 064-127 128-190 191-192 193-255	<b>GOBO WHEEL 2</b> Open Gobo2-1 Gobo2-2 Gobo2-3 Gobo2-4 Gobo2-5 Gobo2-6 Gobo2 1 -6 Shaking Counter-Clockwise rotation, fast to slow Stop Clockwise rotation, slow to fast
<b>12</b>	000-127 128~190 191-192 193-255	<b>R-GOBO 2</b> Index clockwise rotation fast to slow Stop Counter-clockwise rotation slow to fast

<b>13</b>	000-063 064-127 128-255	<b>ANGLE/FROST</b> Off Angle Frost
<b>14</b>	000-009 010-255	<b>PRISM</b> No effect Prism Effect
<b>15</b>	000-127 128-190 191-192 193-255	<b>R-PRISM</b> Index Counter-clockwise rotation fast to slow Stop clockwise rotation slow to fast
<b>16</b>	000-255	<b>FOCUS</b> 0% → 100%
<b>17</b>	000-007 008-015 016-131 132-139 140-181 182-189 190-231 232-239 240-247 248-255	<b>SHUTTER</b> Off On slow to fast strobe open Slow open fast close open Slow close fast open open Random strobe Open
<b>18</b>	000-255	<b>DIMMER</b> 0% → 100%
<b>19</b>	000-255	<b>DIMMER FINE</b>
<b>20</b>	000-069 070-079 080-089 090-099 100-109 110-119 120-129 130-139 140-149 150-159 160-199	<b>SPECIAL FUNCTION</b> No function Enable blackout while Pan/Tilt Moving Disable blackout while Pan/Tilt Moving Enable blackout while Color changing Disable blackout while Color changing Enable blackout while Gobo changing Disable blackout while Gobo changing No function Pan/Tilt reset Effect reset No function

	200-209	All reset
	210-219	Enable blackout while Pan/Tilt Color Gobo Moving
	220-229	Disable blackout while Pan/Tilt Color Gobo Moving
	230-255	No function

## 7. Troubleshooting

Following are a few common problems that may occur during operation. Here are some suggestions for easy troubleshooting:

### A. The unit does not work, no light and the fan does not work

1. Check the connect power and main fuse.
2. Measure the mains voltage on the main connector.
3. Check the power on LED to see if it can be light up or not.

### B. Not responding to DMX controller

1. DMX LED should be on. If not, check DMX connectors, cables to see if they are linked properly.
2. If the DMX LED is on and no response to the channel, check the address settings and DMX polarity.
3. If you have intermittent DMX signal problems, check the pins on connectors or on PCB of the unit or the previous one.
4. Try to use another DMX controller.
5. Check to see if the DMX cables run near or run alongside to high voltage cables that may cause damage or interference to DMX interface circuit.

### C. One of the channels is not working well

1. The stepper motor might be damaged or the cable connected to the PCB is broken.
2. The motor's drive IC on the PCB might be out of condition.

### D. The lamp is cutting out intermittently

1. The lamp is not working well. Check the mains voltage either too high or too low.
2. Internal temperature may be too high. Check if replacement of fan is needed on the head.

## **8. Cleaning**

The cleaning of internal and external optical lenses and/or mirrors must be carried out periodically to optimize light output. Cleaning frequency depends on the environment in which the fixture operates: damp, smoky or particularly dirty surrounding can cause greater accumulation of dirt on the unit's optics.

- Clean with soft cloth and use normal glass to clean liquid.
- Always dry the parts carefully.
- Clean the external optics at least every 20 days. Clean the internal optics at least every 30/60 days.

### **Declaration of Conformity**

We declare that our products (lighting equipments) comply with the following specification and bears CE mark in accordance with the provision of the Electromagnetic Compatibility (EMC) Directive 89/336/EEC.

EN55103-1: 2009+A1:2012; EN55103-2: 2009;  
EN61000-3-2: 2014; EN61000-3-3: 2013.

**&**

### **Harmonized Standard**

EN 60598-1:2015; EN 60598-2-17:1989 + A2:1991;  
EN 62471:2008; EN 62493: 2010  
Safety of household and similar electrical appliances  
Part 1: General requirements

# **Innovation, Quality, Performance**