



ES15-15ES

ES15-33DM

Electric Stacker 1.5t

- 1.5 Ton electric walkie stacker with smallest turning radius;
- High quality mast system meets international regulation;
- Professional cylinder & chain layout provides clear view;
- Maintenance free battery and on board charger

EP EQUIPMENT CO.,LTD
www.ep-ep.com



FEATURE

Performance:

- The innovative AC system offers strong power, accurate control and excellent performance.
- High strength vertical gearbox provides reliable uptime.
- Low-noise and durable hydraulic unit, high quality cylinder as well as hose ensure the high reliability of hydraulic system.
- AMP connector and durable electric wires greatly reduce malfunctions of components.
- H shape channel mast improves the strength of the whole truck.

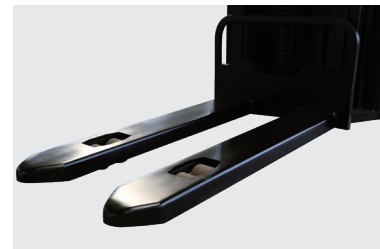

Safety:

- Safe hydraulic system design prevents mast from falling down abruptly when hydraulic pipeline cuts off.
- Emergency reverse belly button protects the operator from getting hurt.
- Emergency disconnect will cut off power source to avoid accident when truck goes out of control.
- Multiple lifting limit protection ensures safety.
- Automatic switch to lower speed when the fork reaches its setting height.
- Anti-rolling back brake keeps the truck from skidding down when truck is out of control or travelling on ramp.
- Long aside tiller reduces operator's hazards.

Operation:

- Ergonomic tiller bounded with key switch, BDI and trouble shooting indicator enhances easy and accurate operation.
- Long tiller offers easier operation.
- Compact chassis design offers smallest turning radius needed.
- Side operating ensures excellent visibility.
- On-board Charger.

Maintenance:

- Maintenance-free Battery.
- Battery display indicator with hour meter, reminds operator of charging on time (optional).
- Easy Maintenance — detachable rear panel.
- Vertical motor makes the inspection & service much more convenient.
- Easy Access of Hand Set.
- Low-voltage Cut-off Protection.

Electric Stacker 1.5t

ES15-15ES

Distinguishing mark				
1.1	Manufacturer			EP
1.2	Model designation			ES15-15ES
1.3	Drive unit			Electric
1.4	Operator type			Pedestrian
1.5	rated capacity	Q	kg	1500
1.6	Load center distance	c	mm	600
1.8	Load distance, centre of drive axle to fork	x	mm	805
1.9	Wheelbase	y	mm	1240
Weight				
2.1	Service weight (include battery)		kg	755
2.2	Axle loading, laden driving side/loading side		kg	805/1450
2.3	Axle loading, unladen driving side/loading side		kg	545/210
Types,Chassis				
3.1	Tyre type Driving wheels/Loading wheels			PU/PU
3.2	Tyre size, driving wheels (diameter×width)		mm	Φ230×75
3.3	Tyre size, loading wheels (diameter×width)		mm	Φ80×60
3.4	Tyre size, caster wheels (diameter×width)		mm	Φ130×55
3.5	Wheels, number driving, caster/loading (x=drive wheels)		mm	1x +2/4
3.6	Track width, front,driving side	b ₁₀	mm	538
3.7	Track width,rear,loading side	b ₁₁	mm	400
Dimensions				
4.2	Height, mast lowered	h ₁	mm	2128
4.3	Free lift	h ₂	mm	
4.4	Lift height	h ₃	mm	3227
4.5	Height, mast extended	h ₄	mm	3743
4.9	Height drawbar in driving position min./max.	h ₁₄	mm	1150/1480
4.15	Lowered height	h ₁₃	mm	88
4.19	Overall length	l ₁	mm	1740
4.20	Length to face of forks	l ₂	mm	575
4.21	Overall width	b ₁	mm	800
4.22	Fork dimensions	s/ e/ l	mm	60×170×1150
4.24	Fork carriage width	b ₃	mm	680
4.25	Outside width of the forks	b ₅	mm	570
4.32	Ground clearance, center of wheelbase	m ₂	mm	28
4.34.1	Aisle width for pallets 1000 × 1200 crossways	Ast	mm	2340
4.34.2	Aisle width for pallets 800 × 1200 lengthways	Ast	mm	2260
4.35	Turning radius	Wa	mm	1500
Performance data				
5.1	Travel speed, laden/ unladen		km/ h	5/5
5.2	Lifting speed, laden/ unladen		m/ s	0.13/0.2
5.3	Lowering speed, laden/ unladen		m/ s	0.13/0.13
5.8	Max. gradeability, laden/unladen		%	8/16
5.10	Service brake type			Electromagnetic
Electric-engine				
6.1	Drive motor rating S2 60 min		kW	1.27
6.2	Lift motor rating at S3 15%		kW	3
6.3	The maximum allowed size battery		mm	330x190x240
6.4	Battery voltage/nominal capacity K20		V/ Ah	2x12/125
6.5	Battery weight		kg	60
Addition data				
8.1	Type of drive unit			AC
10.5	Steering type			Machanical
10.7	Sound pressure level at the driver's ear		dB (A)	74

If there are improvements of technical parameters or configurations, no further notice will be given.
The diagram shown may contain non-standard configurations.

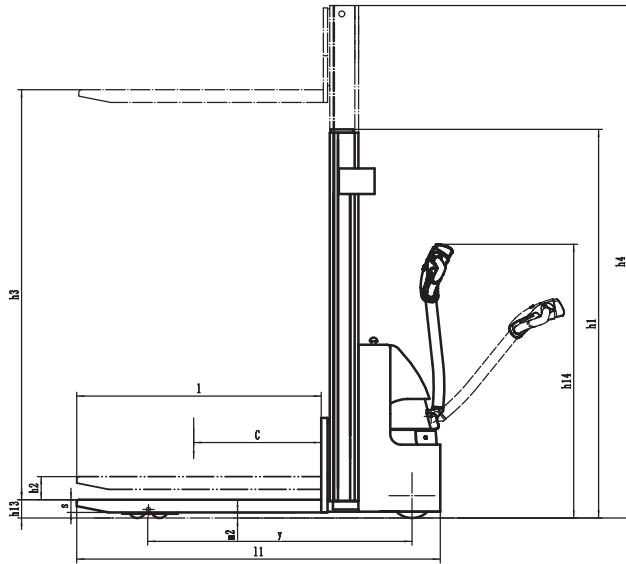

RATED CAPACITIES GRAPH

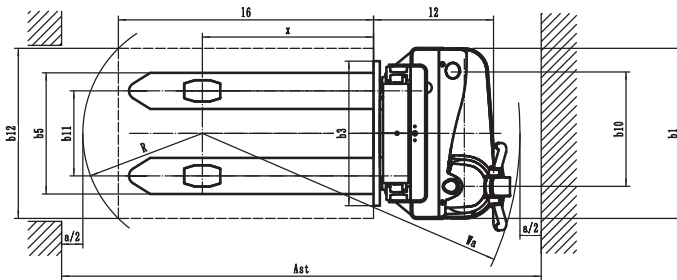
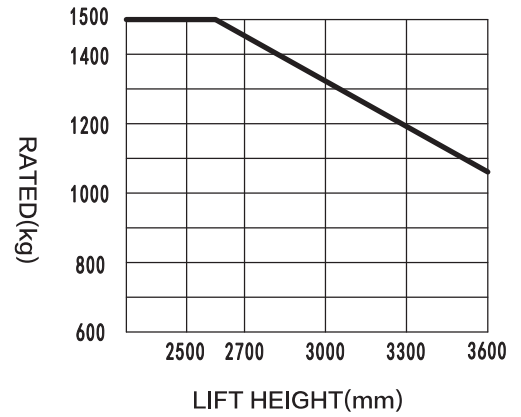

Mast Option

mast types	Lift h3+h13 (mm)	Lowered mast height h1 (mm)	Free lift h2 (mm)	Extended mast height h4 (mm)
Duplex ZT	2515	1728	—	2943
	2715	1828	—	3143
	3015	1978	—	3443
	3315	2128	—	3743

Option

Option	ES15-15ES
Fork width	○685mm/600mm
Battery capacity	●125AH
Special backrest	—
Battery indicator with hour meter	○
Driving wheel	○PU wheel with Pattern
half speed function in turning	—
Mast screen	●organic glass
Height limitation	○
Note:	● standard ○ option — NA

Electric Stacker 1.5t

ES15-33DM

Distinguishing mark				
1.1	Manufacturer			EP
1.2	Model designation			ES15-33DM
1.3	Drive unit			Electric
1.4	Operator type			pedestrian
1.5	rated capacity	Q	kg	1500
1.6	Load center distance	c	mm	600
1.8	Load distance, centre of drive axle to fork	x	mm	730
1.9	Wheelbase	y	mm	1165
Weight				
2.1	Service weight (include battery)		kg	915
2.2	Axle loading, laden driving side/loading side		kg	825/1590
2.3	Axle loading, unladen driving side/loading side		kg	560/355
Types, Chassis				
3.1	Tyre type Driving wheels/Loading wheels			PU/PU
3.2	Tyre size, driving wheels (diameter×width)		mm	Φ230×75
3.3	Tyre size, loading wheels (diameter×width)		mm	Φ102×73
3.4	Tyre size, caster wheels (diameter×width)		mm	Φ100×50
3.5	Wheels, number driving, caster/loading (x=drive wheels)		mm	1x +1/4
3.6	Track width, front, driving side	b ₁₀	mm	538
3.7	Track width, rear, loading side	b ₁₁	mm	1170/1270/1370
Dimensions				
4.2	Height, mast lowered	h ₁	mm	2128
4.3	Free lift	h ₂	mm	
4.4	Lift height	h ₃	mm	3230
4.5	Height, mast extended	h ₄	mm	4210
4.9	Height drawbar in driving position min./max.	h ₁₄	mm	1150/1480
4.15	Lowered height	h ₁₃	mm	60
4.19	Overall length	l ₁	mm	1650
4.20	Length to face of forks	l ₂	mm	580
4.21	Overall width	b ₁ / b ₂	mm	1270/1370/1470
4.22	Fork dimensions	s/ e/ l	mm	40/ 100/ 1070
4.24	Fork carriage width	b ₃	mm	800
4.25	Outside width of the forks	b ₅	mm	200~765
4.32	Ground clearance, center of wheelbase	m ₂	mm	30
4.34.1	Aisle width for pallets 1000 × 1200 crossways	Ast	mm	2250
4.34.2	Aisle width for pallets 800 × 1200 lengthways	Ast	mm	2200
4.35	Turning radius	Wa	mm	1400
Performance data				
5.1	Travel speed, laden/ unladen		km/ h	5/5
5.2	Lifting speed, laden/ unladen		m/ s	0.14/0.2
5.3	Lowering speed, laden/ unladen		m/ s	0.13/0.11
5.8	Max. gradeability, laden/unladen		%	8/16
5.10	Service brake type			Electromagnetic
Electric engine				
6.1	Drive motor rating S2 60 min		kW	1.27
6.2	Lift motor rating at S3 15%		kW	3
6.3	The maximum allowed size battery		mm	330x190x240
6.4	Battery voltage/nominal capacity K20		V/ Ah	24/125
6.5	Battery weight		kg	60
Addition data				
8.1	Type of drive unit			AC
10.5	Steering type			Machanical Steering
10.7	Sound pressure level at the driver's ear		dB (A)	74

If there are improvements of technical parameters or configurations, no further notice will be given.
The diagram shown may contain non-standard configurations.

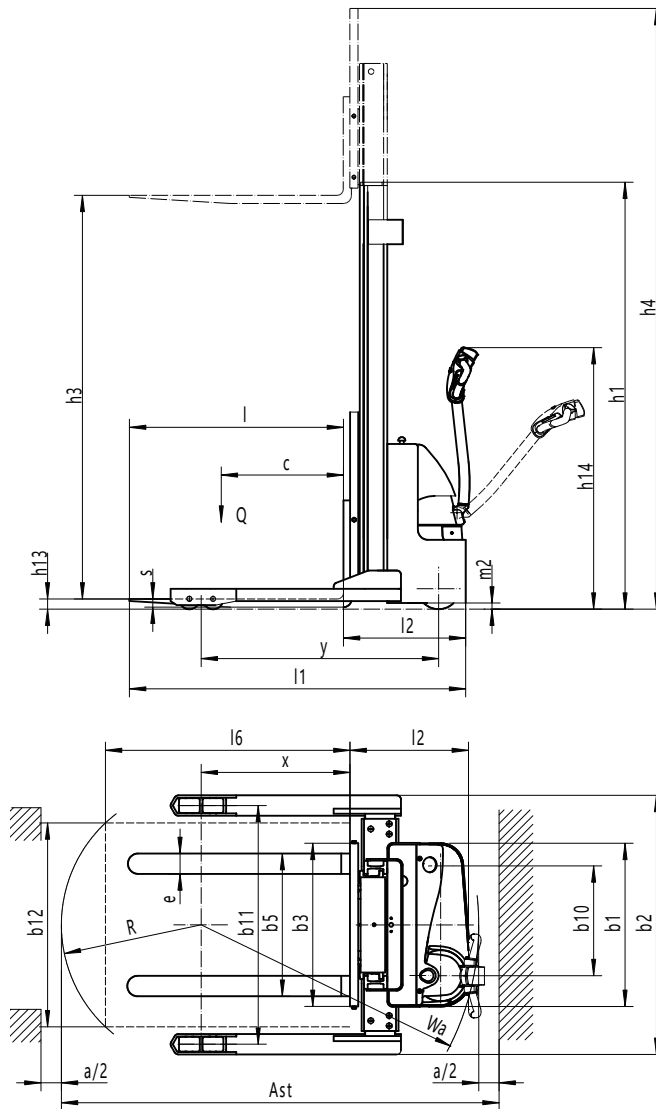

RATED CAPACITIES GRAPH

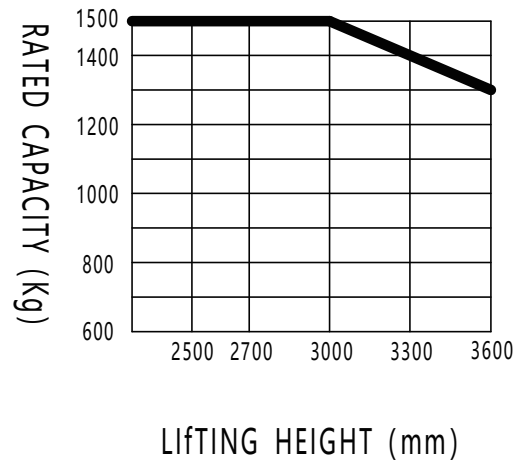

Mast Option

Mast types	Close Mast height h1	Free height h2	lift height h3+h13	Extended Mast Height h4
Two Stage Mast	1728	—	2490	3410
	1828	—	2690	3610
	1978	—	2990	3910
	2128	—	3290	4210

Option

Option	ES15-33DM
Fork width	—
Battery capacity	●125AH
Special backrest	●
Battery indicator with hour meter	○
Driving wheel	○PU wheel with Pattern
half speed function in turning	—
Mast screen	●organic glass
Height limitation	○

Note: ● standard ○ option — NA