



CQD16/20L

Electric Reach Truck 1.6/2.0T

- Optimal visibility
- High stability
- Enjoyable lifting operation
- Easy and precise operation

LI-ION
TECHNOLOGY

EP EQUIPMENT CO.,LTD
www.ep-ep.com

FEATURE



Optimal visibility

A much more compact li-ion battery comes with better visibility for CQD16L/20L. Along with the offset layout of the oil tubes, CQD16L/20L stacking visibility and operation flexibility are greatly improved.



360Ah
Li-Ion Battery



200A
Charger



550mm/s
Lifting Speed



9.3km/h
Driving Speed



Lithium-ion technology

CQD16L/20L is powered by a maintenance-free 48V/360Ah Li-Ion battery. Along with the opportunity charging capability, li-Ion batteries have much faster charging times than lead-acid batteries. EP's BMS, based on CANBUS system, allows battery cells communicate among each other to deliver powerful performance at all times.



Enjoyable lifting operations

CQD16L and CQD20L offers powerful performance and quiet operations through the upgraded hydraulic pumps and powerful lifting motors. (11.75 kw for CQD16L and 20 kw for CQD20L.) The upgraded technology greatly boosts stacking efficiency by 50%, reduces operational noise by 10 dB and the energy consumption by 30%.



Easy and precise operations

CQD20L is equipped with an mechanic height indicator, that tells operators the correct height of the fork at various rack levels for precise operations to improve the stacking efficiency.

FEATURE



■ High stability

The low center of gravity and the newly I-beam mast design enhance the truck stability. The maximum lifting height of CQD16L is 8000 mm while the one of CQD20L is 12000 mm.



■ Electric Power Steering

CQD16L and CQD20L come with full AC motors and electric power steering system that consumes less power compared to hydraulic power steering while keeps operation habits of trucks with mechanical steering through the additional damping force. So CQD16L and CQD20L give more working hours than ones with hydraulic power steering.



■ Full-color Display

CQD16L and CQD20L are designed with a color display to help operators easily monitor battery charge level, driving speed, and check error codes.



■ 6000K Led Light

CQD16L and CQD20L are equipped with 6000K led lights to cope with the dark environment for optimal visibility.

Electric Reach Truck 1.6T

CQD16L

Distinguishing mark	1.1	Manufacturer			EP
	1.2	Model designation			CQD16L
	1.3	Drive unit			Electric
	1.4	Operator type			Seated
	1.5	Rated capacity	Q	kg	1600
	1.6	Load center distance	c	mm	600
	1.8	Load distance, centre of drive axle to fork	x	mm	390③
	1.9	Wheelbase	y	mm	1474
	Service weight	2.1	Service weight		kg
2.3.1		Axle loading, unladen front/rear		kg	1840/1060
2.4.1		Axle loading, fork advanced, laden front/rear		kg	470/4060
2.5.1		Axle loading, fork retracted, laden front/rear		kg	1500/3040
Tyres/chassis	3.1	Tyre type			Polyurethane
	3.2.1	Tyre size, front		mm	Φ260×105
	3.3.1	Tyre size, rear		mm	Φ254×114
	3.4	Additional wheels		mm	Φ102×51
	3.5.1	Wheels, number front/rear (x=drive wheels)		mm	1x/2
	3.6	Tread, front	b10	mm	—
	3.7	Tread, rear	b11	mm	974
	4.1	Tilt of mast/fork carriage forward/backward	α/β	°	2/4
Dimensions	4.2	Height, mast lowered	h1	mm	2780②
	4.3	Free lift	h2	mm	1522②
	4.4	Lift height	h3	mm	6500②
	4.5	Height, mast extended	h4	mm	7535②
	4.7	Height of overhead/ guard cabin	h6	mm	2153
	4.8	Seat height/standing height	h7	mm	1050
	4.10	Height of wheel arms	h8	mm	277
	4.19	Overall length	l1	mm	2434③
	4.20	Length to face of forks	l2	mm	1330③
	4.21	Overall width	b1/b2	mm	1080/1090
	4.22	Fork dimensions	s/e/l	mm	40/100/1070
	4.23	A,B Fork carriage class/type A, B			2A
	4.24	Fork carriage width	b3	mm	872③
	4.25	Distance between fork-arms	b5	mm	200-655③
	4.26	Distance between wheel arms/loading surfaces	b4	mm	750
	4.28	Reach distance	l4	mm	590③
	4.31	Ground clearance, laden, below mast	m1	mm	80
	4.32	Ground clearance, center of wheelbase	m2	mm	70
	4.34.1	Aisle width for pallets 1000×1200 crossways	Ast	mm	2789③
	4.34.2	Aisle width for pallets 800×1200 crossways	Ast	mm	2840③
4.35	Turning radius	Wa	mm	1720	
4.37	Length across wheel arms	l7	mm	1870	
Performance data	5.1	Travel speed, laden/unladen		km/h	9/9.3
	5.2	Lifting speed, laden/unladen		m/s	0.35/0.55
	5.3	Lowering speed, laden/unladen		m/s	0.55/0.5
	5.4	Reaching speed, laden /unladen		m/s	0.15/0.15
	5.8	Max. gradeability, laden/unladen		%	8/10
	5.10	Service brake			Electromagnetic
5.11	Parking brake			Electromagnetic	
Electric-engine	6.1	Drive motor rating S2 60 min		kW	4
	6.2	Lift motor rating at S3 15%		kW	11.75
	6.4	Battery voltage/nominal capacity		V/Ah	48/360④
	6.5	Battery weight		kg	450④
Addition data	8.1	Type of drive unit			AC
	10.5	Steering design			Electronic
	10.7	Sound pressure level at the driver's ear		dB(A)	75

If there are improvements of technical parameters or configurations, no further notice will be given.
The diagram shown may contain non-standard configurations.

Electric Reach Truck 2.0T

CQD20L

Distinguishing mark	1.1	Manufacturer			EP
	1.2	Model designation			CQD20L
	1.3	Drive unit			Electric
	1.4	Operator type			Seated
	1.5	Rated capacity	Q	kg	2000
	1.6	Load center distance	c	mm	600
	1.8	Load distance, centre of drive axle to fork	x	mm	377
	1.9	Wheelbase	y	mm	1515
	Service weight	2.1	Service weight		kg
2.3.1		Axle loading, unladen front/rear		kg	2210/1320
2.4.1		Axle loading, fork advanced, laden front/rear		kg	470/5060
2.5.1		Axle loading, fork retracted, laden front/rear		kg	1870/3620
Tyres/chassis	3.1	Tyre type			Polyurethane
	3.2.1	Tyre size, front		mm	Φ343×140
	3.3.1	Tyre size, rear		mm	Φ310×118
	3.4	Additional wheels		mm	Φ102×51
	3.5.1	Wheels, number front/rear (x=drive wheels)		mm	1x/2
	3.6	Tread, front	b10	mm	—
	3.7	Tread, rear	b11	mm	1148
Dimensions	4.1	Tilt of mast/fork carriage forward/backward	α/β	°	2/4
	4.2	Height, mast lowered	h1	mm	3219 ^②
	4.3	Free lift	h2	mm	1712 ^②
	4.4	Lift height	h3	mm	7500 ^②
	4.5	Height, mast extended	h4	mm	8565 ^②
	4.7	Height of overhead/ guard cabin	h6	mm	2213
	4.8	Seat height/standing height	h7	mm	1076
	4.10	Height of wheel arms	h8	mm	333
	4.19	Overall length	l1	mm	2463
	4.20	Length to face of forks	l2	mm	1393
	4.21	Overall width	b1/b2	mm	1260/1270
	4.22	Fork dimensions	s/e/l	mm	40/120/1070
	4.23	A,B Fork carriage class/type A, B			2A
	4.24	Fork carriage width	b3	mm	990
	4.25	Distance between fork-arms	b5	mm	240-770
	4.26	Distance between wheel arms/loading surfaces	b4	mm	915
	4.28	Reach distance	l4	mm	585
	4.31	Ground clearance, laden, below mast	m1	mm	60
	4.32	Ground clearance, center of wheelbase	m2	mm	75
	4.34.1	Aisle width for pallets 1000×1200 crossways	Ast	mm	2835
4.34.2	Aisle width for pallets 800×1200 crossways	Ast	mm	2885	
4.35	Turning radius	Wa	mm	1770	
4.37	Length across wheel arms	l7	mm	1948	
Performance data	5.1	Travel speed, laden/unladen		km/h	10/11
	5.2	Lifting speed, laden/unladen		m/s	0.38/0.55
	5.3	Lowering speed, laden/unladen		m/s	0.41/0.38
	5.4	Reaching speed, laden /unladen		m/s	0.18/0.18
	5.8	Max. gradeability, laden/unladen		%	10/15
	5.10	Service brake			Electromagnetic
5.11	Parking brake			Electromagnetic	
Electric-engine	6.1	Drive motor rating S2 60 min		kW	7
	6.2	Lift motor rating at S3 15%		kW	20
	6.4	Battery voltage/nominal capacity		V/Ah	48/360 ^④
	6.5	Battery weight		kg	350 ^④
Addition data	8.1	Type of drive unit			AC
	10.5	Steering design			Electronic
	10.7	Sound pressure level at the driver's ear		dB(A)	75

If there are improvements of technical parameters or configurations, no further notice will be given.
The diagram shown may contain non-standard configurations.

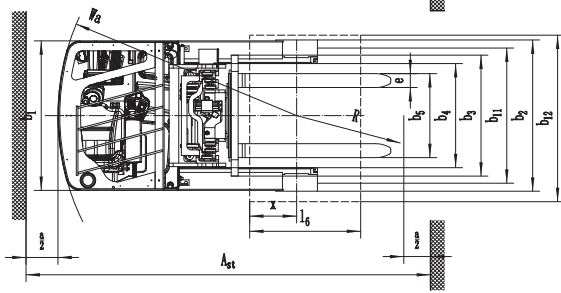
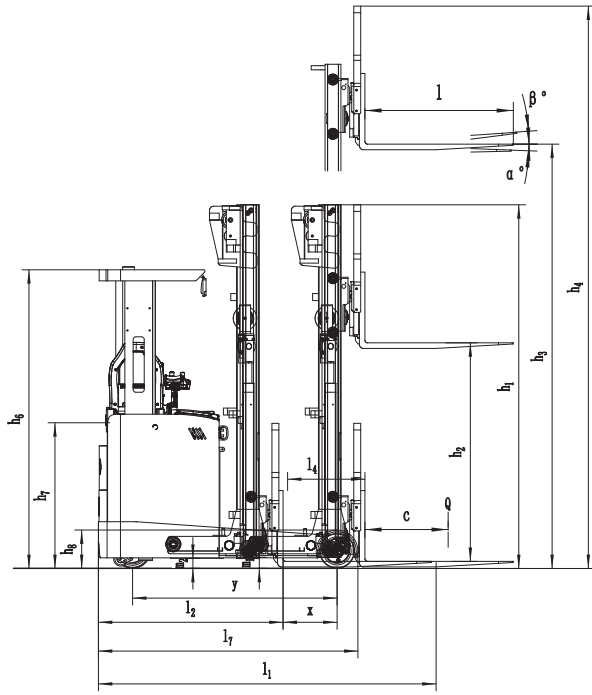

CQD16L

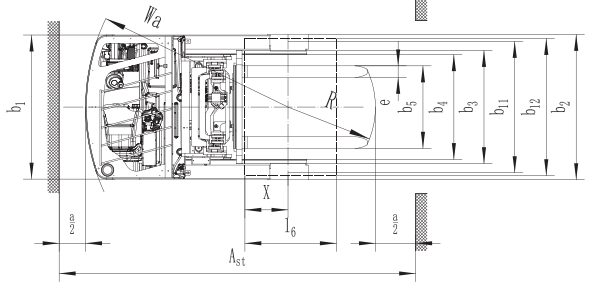
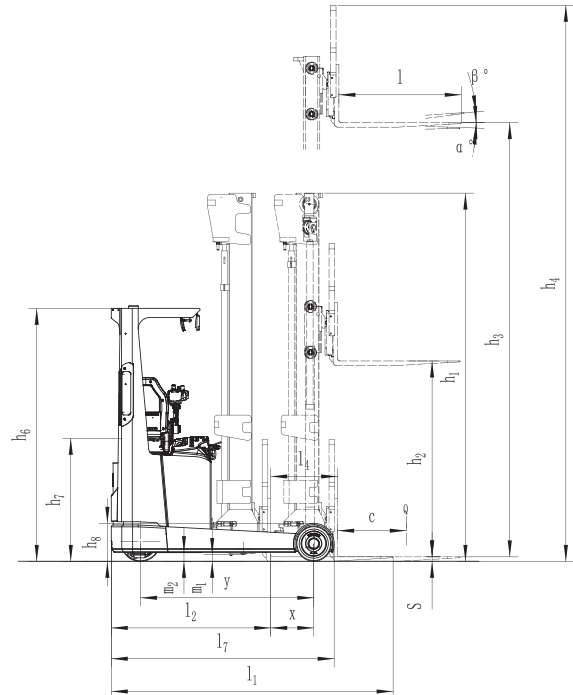

CQD20L

RATED CAPACITIES GRAPH

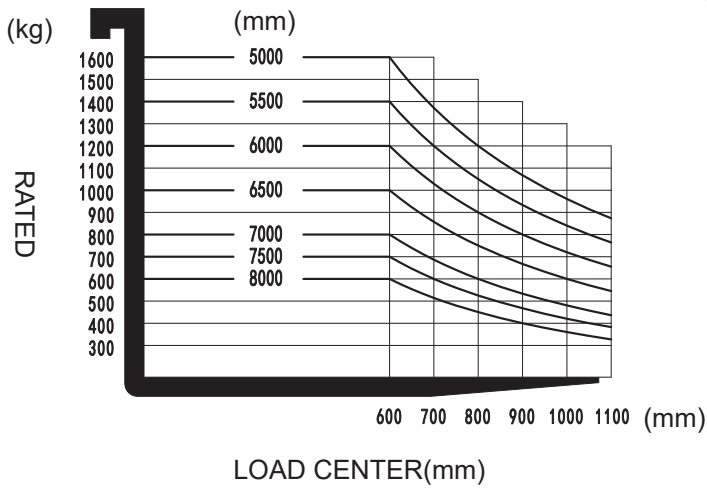

RATED CAPACITIES GRAPH

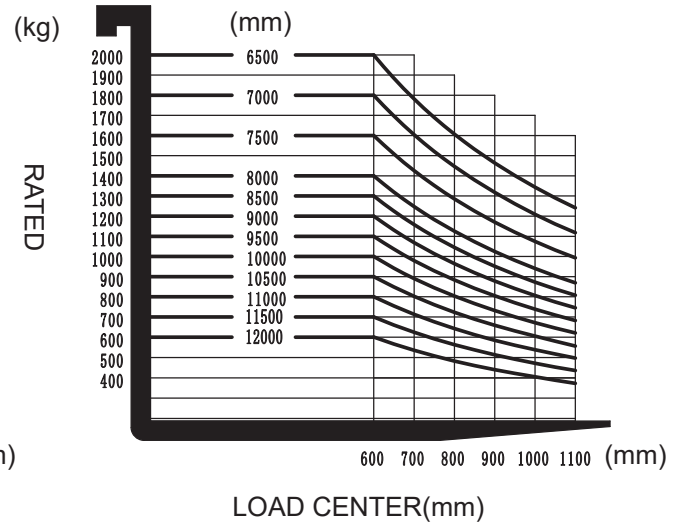

Mast Option(CQD16L)

①Service weight (include battery)

Mast height(mm)	Service weight(kg)	Mast height(mm)	Service weight(kg)
2-stage mast		3-stage mast	
2700	2497	4000	2662
3000	2522	4500	2697
3300	2547	5000	2733
3640	2572	5500	2769
4000	2597	6000	2805
4300	2622	6500	2840
—	—	7000	2876
—	—	7500	2912
—	—	8000	2956

②Mast

without side shift: 2-stage mast			
Lift height	Lowered mast height	Extended mast height	
h3	h1	h4	h4(*)
2700	1900	3560	3266
3000	2050	3860	3566
3300	2200	4160	3866
3640	2370	4500	4206
4000	2550	4860	4566
4300	2700	5160	4866

Note: (*) for without backrest

without side shift: 3-stage mast					
Lift height	Lowered mast height	Free lift		Extended mast height	
h3	h1	h2	h2(*)	h4	h4(*)
4000	1930	662	662	4899	4899
4500	2100	842	842	5399	5399
5000	2270	1002	1002	5899	5899
5500	2440	1182	1182	6399	6399
6000	2610	1342	1342	6899	6899
6500	2780	1522	1522	7399	7399
7000	2950	1682	1682	7899	7899
7500	3120	1842	1842	8399	8399
8000	3330	2102	2102	8899	8899

Note: (*) for without backrest

with side shift: 2-stage mast			
Lift height	Lowered mast height	Extended mast height	
h3	h1	h4	h4(*)
2700	1900	3735	3266
3000	2050	4035	3566
3300	2200	4335	3866
3640	2370	4675	4206
4000	2550	5035	4566
4300	2700	5335	4866

Note: (*) for without backrest

with side shift: 3-stage mast					
Lift height	Lowered mast height	Free lift		Extended mast height	
h3	h1	h2	h2(*)	h4	h4(*)
4000	1930	662	662	5035	4899
4500	2100	842	842	5535	5399
5000	2270	1002	1002	6035	5899
5500	2440	1182	1182	6535	6399
6000	2610	1342	1342	7035	6899
6500	2780	1522	1522	7535	7399
7000	2950	1682	1682	8035	7899
7500	3120	1842	1842	8535	8399
8000	3330	2102	2102	9035	8899

Note: (*) for without backrest

③Dimensions(mm)

		without side shift		with side shift	
		2-stage mast	3-stage mast	2-stage mast	3-stage mast
Overall length (minimum)	l1	2377	2399	2412	2434
Length to face of forks	l2	1273	1295	1308	1330
Fork carriage width	b3	837		872	
Outside width of the forks	b5	200-620		200-655	
Reach distance	l4	625		590	
Aisle width for pallets 1000×1200 crossways	Ast	2749	2764	2774	2789
Aisle width for pallets 800×1200 lenthways	Ast	2789	2809	2821	2840
Aisle width for pallets 1000×1200 lenthways	Ast	2840	2858	2869	2888
Aisle width for pallets 800×1200 crossways	Ast	2626	2638	2645	2666

④Battery

Capacity(Ah)	Battery weight (kg)
280	450
360	465

Mast Option(CQD20L)

①Service weight (include battery)

Mast height(mm)	Service weight(kg)	Mast height(mm)	Service weight(kg)
2-stage mast		3-stage mast	
2700	2847	4050	3138
3000	2872	4500	3180
3300	2896	5000	3223
3640	2924	5500	3271
4000	2953	6000	3320
4300	2977	6500	3363
4520	3005	7000	3479
5000	3044	7500	3510
5480	3086	8000	3569
6000	3143	8500	3629
—	—	9000	3688
—	—	9500	3736
—	—	10000	3850
—	—	10500	3898
—	—	11000	3944
—	—	11500	3991
—	—	12000	4037

②Mast

2-stage mast					
Lift height	Lowered mast height	Free lift		Extended mast height	
h3	h1	h2		h4	h4(*)
2700	1980	120		3765	3280
3000	2130	120		4065	3580
3300	2280	120		4365	3880
3640	2450	120		4705	4220
4000	2630	120		5065	4580
4300	2780	120		5365	4880
4520	2960	160		5585	5140
5000	3200	160		6065	5620
5480	3460	160		6545	6120
6000	3720	160		7065	6640

Note: (*) for without backrest

3-stage mast					
Lift height	Lowered mast height	Free lift		Extended mast height	
h3	h1	h2	h2(*)	h4	h4(*)
4050	1999	522	522	5115	5113
4500	2149	672	672	5565	5563
5000	2299	772	772	6065	6063
5500	2469	952	952	6565	6563
6000	2649	1172	1172	7065	7063
6500	2799	1272	1272	7565	7563
7000	3049	1532	1532	8065	8063
7500	3219	1712	1712	8565	8563
8000	3389	1852	1852	9065	9063
8500	3609	2072	2072	9565	9563
9000	3769	2212	2212	10065	10063
9500	3939	2392	2392	10565	10563
10000	4159	2612	2612	11065	11063
10500	4329	2792	2792	11565	11563
11000	4489	2932	2932	12065	12063
11500	4659	3112	3112	12565	12563
12000	4819	3252	3252	13065	13063

Note: (*) for without backrest

④Battery

Model	CQD20L	
Li-Ion Battery Capacity	360Ah	560Ah
Li-Ion Battery Weight	350kg	350kg

Option(CQD16L)

Options		CQD16L(Electromagnetic Proportional Valve)
Light	Warning Light	●
	LED Front Light	●
	Blue Light	○
	Regional Warning Light	○
Attachment	Fork2A,40×100×1070	●
	Integrated Side Shift(4-valve)	○
Battery	360Ah	●
	280Ah	○
Charger	48V/150A yaneng	○
	48V/200A yaneng	●
	48V/200A Shineng	○
OPS		●
Wireless Camera		○
Reversing Hummer		○
Cold Storage		○
Telematics		○
Note: ●Standard ○Option —NA		
Double front led light, rearview mirror (one), warning lights, suspension seat as standard.		

Option(CQD20L)

Options		CQD20L
Light	Warning Light	●
	LED Front Light	●
	Blue Light	○
	Regional Warning Light	○
Attachment	Fork2A,40×120×1070	●
	Integrated Side Shift(4-valve)	●
Battery	360Ah	●
	560Ah	○
Charger	48V/200A yaneng	●
	48V/200A Shineng	○
OPS		●
Wireless Camera		○
Reversing Hummer		○
Cold Storage		○
Telematics		○
Height display , height indicator (only for 3-stage mast)		●
Note: ●Standard ○Option —NA		