

NATRON

Solar LED Street Light 40W/30W



Introducing our advanced SOLAR AREA LIGHTS in 5 variants: Beyond Solar proudly presents the Natron Solar Street Light, featuring an exceptionally straightforward installation process, a departure from conventional lead-acid battery systems. This cutting-edge solution boasts a smart and distinctive design, incorporating the finest components available in the market. With a LIFEP04 battery, MPPT controller, and a robust aluminum construction, Natron stands out as the most powerful and dependable solar lighting solution.

NOMINAL FLUX.....**7840 LUMENS or 5880 LUMENS**
 NOMINAL POWER.....**40 Watt or 30 Watt**

LIGHTING

Efficiency..... 196 Lumens/Watt
 Chips LED..... **PHILIPS Luxeon 30-30**
 LED Lifetime..... **Over 80000 hours LM80**
 Optics/CCT..... **TII-S / T3-M/ T-V -- 2300 to 6500K**
 Light Height choose from..... **From 13' to 20' or 13' to 16.5' Feet**

BATTERY

Technology..... **Lithium Iron Phosphate LIFEP04**
 Capacity..... **627Wh or 460Wh**
 Autonomy..... **Over 24 hours at full charge - 4 Rainy Days back up**
 Charging Time..... **5-6 hours**
 Lifespan..... **Over 3000 CYCLES @ 80% DOD over 10 years Lifetime**
 Working Temp..... **14F to 158F - (Optional -40F TO 158F)**

ENERGY

Solar panel..... **135 Wattv or 125 Watt /18V**
 Cells Type..... **Monocrystalline Panel Grade A 25 years**
 Certificates..... **IEC 61215 - IEC 61730 I and II - IEC 60904**

ELECTRONIC

Controller..... **MPPT SMART CONTROLLER (Beyond Solar BRIDGE Optional)**
 Sensor..... **Microwave 360° Motion Sensor**
 Cabling..... **Waterproof Connector, Plug and Play**
 Protection..... **Battery Management System (BMS)**

ELECTRONIC

Pole mounting..... **3.50" or 3" Inches**
 Material..... **Aluminium and Stainless Steel**

DIMENSIONS

Product..... **55.51" x 22.04" x 5.90"**
 Carton Size..... **57.48" x 24.01" x 10.23"**
 Net Weight..... **45.19 LBS or 42.54 LBS**
 Gross Weight..... **53 LBS or 52.24 LBS**
 QTY /CTN 20"/40"..... **105/220**
 Product Model..... **AVS-SSLXPRO-40W / AVS-SSLXPRO-30W**

Beyond Solar retains the right to modify or change product specifications without prior notice, as part of our ongoing commitment to improvement

Model #	SKU #	Fixture Height	Power	PV Type	Solar Panel	Lithium Battery	Lumens	CCT	IP Rating	Material
AVS-SSLXPRO-40W	786158	13 to 20Ft	40W	MONO	135W	49AH 12.8V	7840LM	2300K - 6500K	IP65	ALUMINUM
AVS-SSLXPRO-30W	786159	13 to 16.5Ft	30W	MONO	125W	36AH 12.8V	5880LM	2300K - 6500K	IP65	ALUMINUM



LUMINAIRE HOUSING

LEDs

7840 LUMENS or 5880 LUMENS - 2300K TO 6500 K

High pressure die-cast low-copper aluminum. Protection class (IP65). Beyond Solar uses a high quality Polyester Powder Coating from AKZO NOBEL. This powder coating provides an excellent salt and humidity resistance as well as ultra violet resistance for color retention for this product.

Our Luminaire is equipped with PHILIPS LUXEON HE PLUS High efficiency Chips offering and overall 196 Lumens per Watt efficacy.

Our luminaire also complies with the DARK SKY requirement for light pollution with an Upward lighting of 0.31%.

▶ LED	3030	LED QTY (PCS) 96	LENS (PCS) 4	CRI > 80
-------	-------------	-------------------------	---------------------	--------------------



IP65

DIFFERENT OPTICS*

Our different optics will allow you to optimize the lighting results of your projects



**Please contact us for more optics.*

LIGHT DISTRIBUTION CURVES

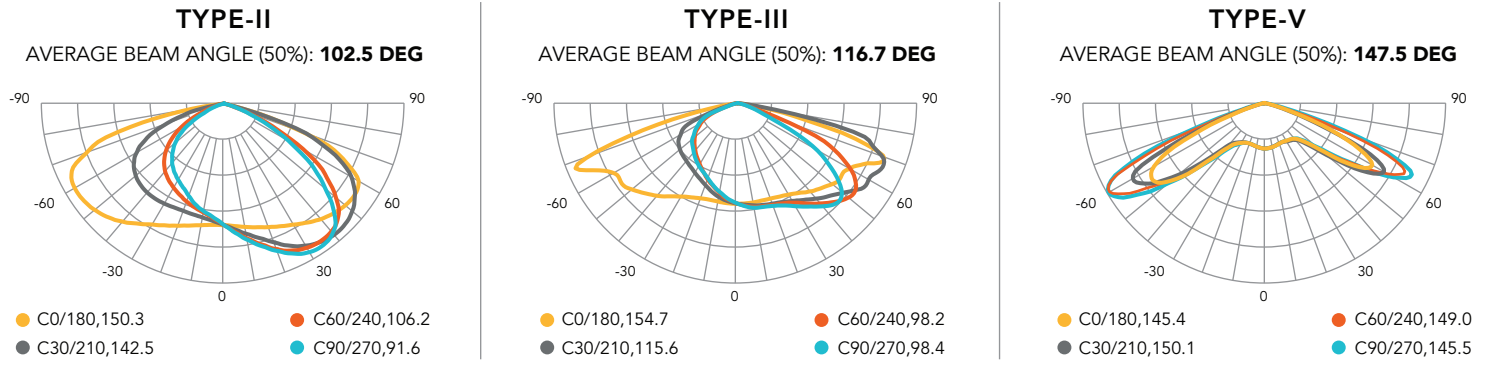

SELECTION : TYPE-II TYPE-III TYPE-VI



CORRELATED COLOR TEMPERATURE

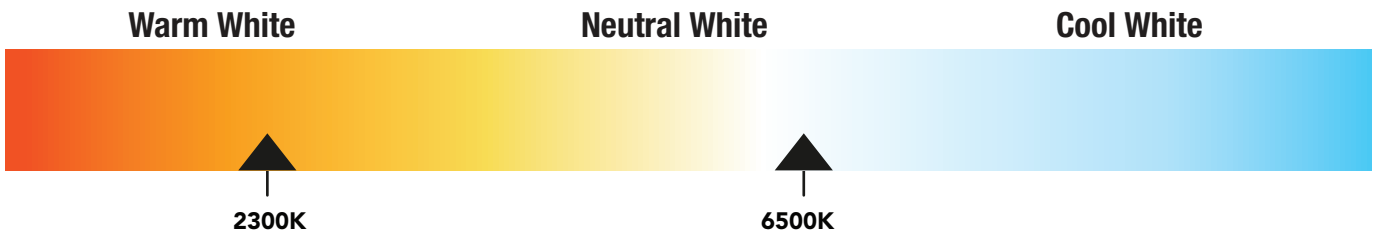

BATTERY LIFEPO4

+ OVER 10 YEARS LIFETIME

The NATRON is equipped with Iron Phosphate Lithium LiFePo4 battery. This technology is proved to be the best chemical technology for solar application on the market.

With a cycle life of over 3000 Cycles @ 80% DOD, the battery enjoys lifespan of over 10 years.

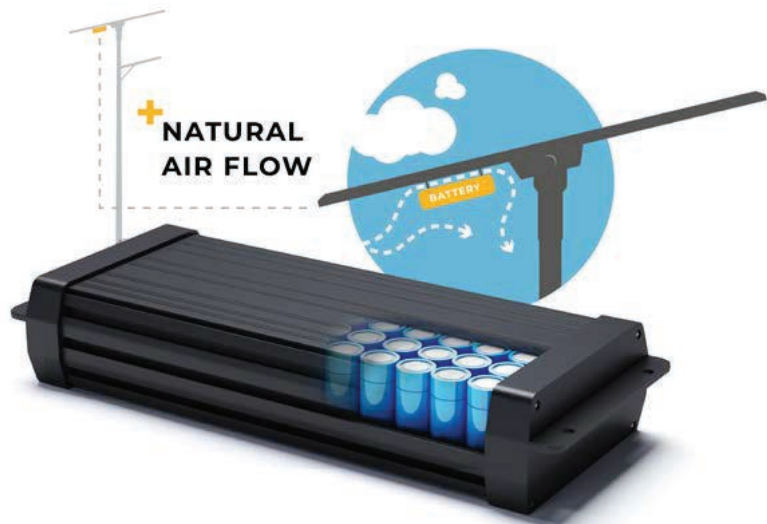

EXTREME TEMPERATURE

14F TO 158F (-40F OPTIONAL)

When Standard Lithium LiFePo4 batteries enjoy a working temperature range from 14F TO158F. Beyond Solar offers as optional a new Special LIFEPO4 battery with working range of -40F. to 158F.

EASY MAINTENANCE & ANTI THEFT SCREWS

Easy and direct access to the battery casing for maintenance. The fixation is made with anti theft screws, which request special tooling to unscrew.

ALUMINUM WATERPROOF CASING & NATURAL AIRFLOW

High temperatures greatly negatively affect the battery's lifespan. This is why our batteries are encapsulated in an aluminum waterproof casing for a perfect heat dissipation.

In addition to that, the casing enjoys a natural airflow which keeps the battery to ambient temperature.

BMS ELECTRONIC PROTECTION BATTERY MANAGEMENT SYSTEM

Our batteries are equipped with electronic circuit boards for a higher protection, ensuring battery functioning optimization no matter the situation.

THE BMS PROTECTS AGAINST

- OVER/UNDER POWER • OVERLOAD • OVER/UNDER VOLTAGE
- OVER/UNDER CHARGE • TEMPERATURE MANAGEMENT

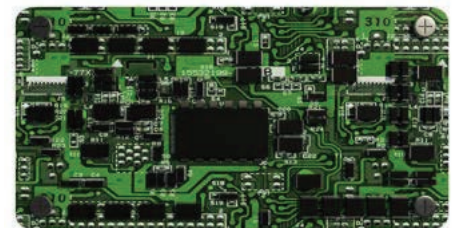

SOLAR PANEL

135 WATT or 125 WATT

High efficiency mono-crystalline Solar panels. Carefully selected **Grade A** Solar cells. Up to 20.4% efficiency, all protected by self-cleaning tempered glass at 30 degrees of inclination.

Its octagonal Anodized aluminium alloy frame gives it a modern and elegant design as well as perfect resistance to corrosion. They are also equipped with fully waterproof Plug and Play connectors.

OUR PV PERFORMANCE GUARANTEE

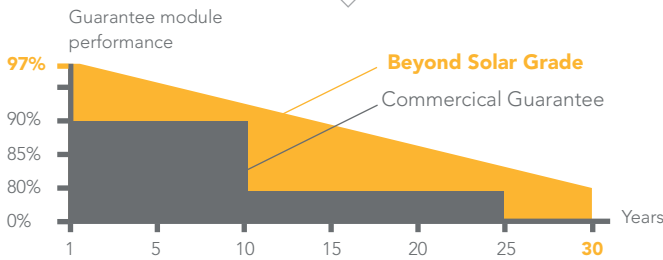

Solar cells **GRADE A**



CONTROLLER MPPT



+ WATERPROOF CONNECTORS "PLUG & PLAY"

All our components are assembled **Seamless and easy to access**

In a search for performance and reliability, our products are equipped with MPPT technology controller offering the best charging efficiency on the market up to 98%

REMOTE CONTROL MONITORING

In order to facilitate all maintenance operations and above all to diagnose any possible problem, without having to intervene mechanically on the luminaire, Beyond Solar luminaires are equipped with a wireless diagnostic system via remote control.



With a simple click it is possible to have real-time information such as:

- Automatic diagnosis in case of malfunction
- State of charge and battery history
- Real Time load and solar panel energy production history
- Age of the product and installation
- Temperature and its history

FEATURES

- Minimal stand-by power consumption
- Current consumption $\leq 10\text{mA}$
- Intelligent battery management

3 Phases charging:

- Charge MPPT
- Constant voltage
- Floating voltage

- Intelligent LED driver Auto detecting of Dusk and Dawn for automatic operation, 7 Lighting Programs Configuration.
- ANTI BLACK OUT : Load adjust according to battery capacity assuring all night long lighting in any weather conditions.
- The controller also acts against
 - OVERLOAD
 - OVERCURRENT
 - OVERTEMPERATURE
 - OVERVOLTAGE / OVERLOAD
 - OVERDISCHARGE



MOTION SENSOR MICROWAVE

Beyond Solar luminaires are equipped with microwave sensors that use the Doppler effect (like car radars) to detect a nearby objects and measure the distance. The sensor emits a high frequency wave to reflect off of and analyze the objects in the vicinity.

Since the microwaves only detect specific objects, detection reliability increases resulting in:

- Much better reliability compared to the Infrared sensor
- Up to 360° Directivity
- Insensitivity to other environmental variations such as light, color, temperature, etc.

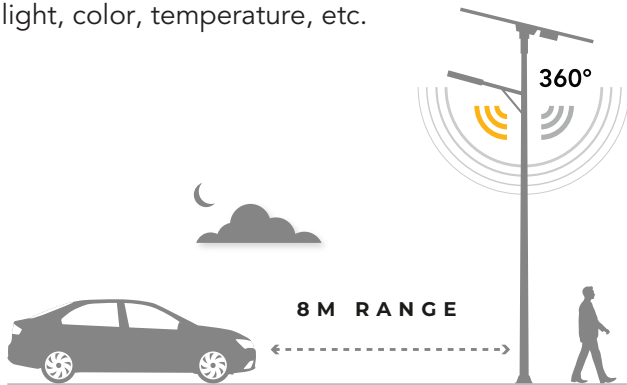

OPERATION MODE & LIGHTING SCHEDULE

In addition to automatic switching on and off, you have the possibility of choosing among different modular operating modes according to the needs of the project

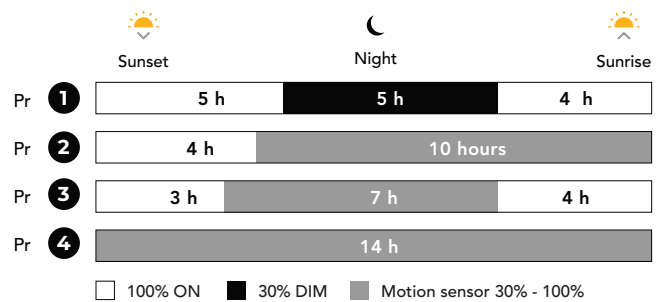

CONTACT US FOR MORE PROGRAM OPTIONS

REMOTE MONITORING SOLAR BRIDGE

As part of his continuous effort for development, the Beyond Solar team is proud to have developed a special tool for remote monitoring of our solar street light. Beyond Solar Bridge uses low frequency technology LORA or ZIGBEE to monitor in real time a batch of solar street lights.

YOU CAN NOW MANAGE YOUR SOLAR PARK REMOTELY

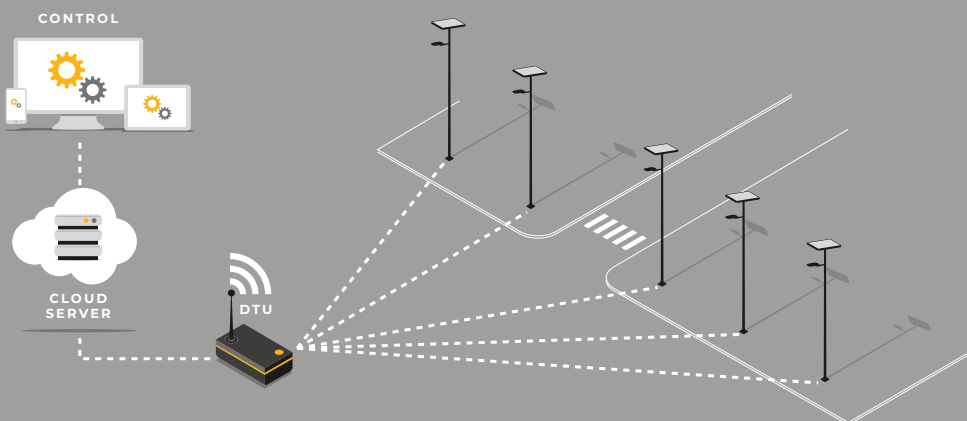

- INTERNET 2G/3G/4G
- CONNECTION SECURE
- GREAT RANGE OF COMMUNICATION
- LOW CONSUMPTION



EASY INSTALLATION

NO CABLING • NO TRENCHING

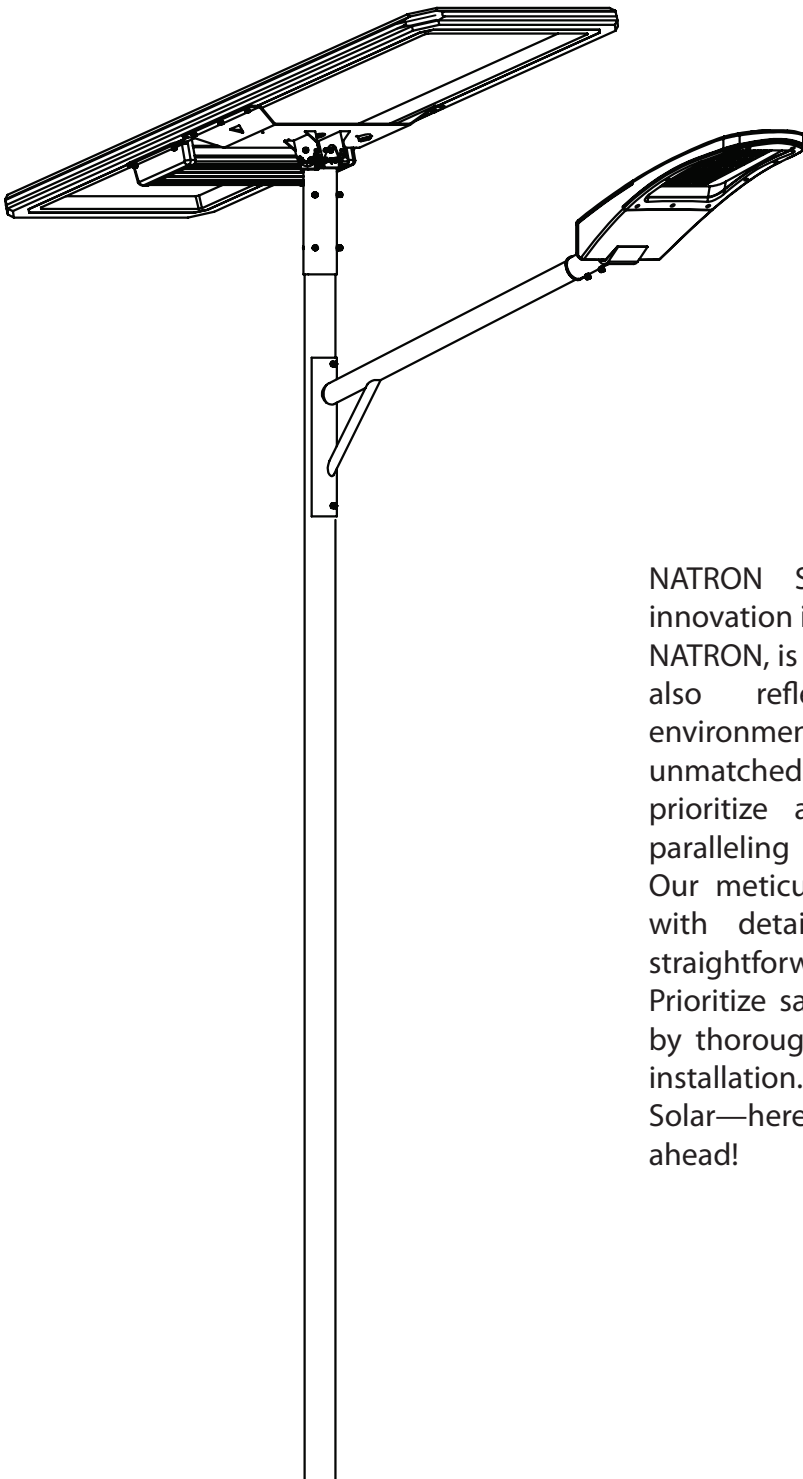

NATRON Street Light Split System, an innovation in renewable energy solutions. The NATRON, is not only illuminates efficiently but also reflects our commitment to environmental sustainability, ensuring unmatched performance and durability. We prioritize a seamless installation process, paralleling the technology's sophistication. Our meticulously crafted manual, complete with detailed illustrations, guarantees a straightforward and hassle-free setup. Prioritize safety and the NATRON's longevity by thoroughly reviewing the manual before installation. Thank you for choosing Beyond Solar—here's to brighter, greener nights ahead!

1. CAUTIONS

To ensure the longevity and optimal performance of your NATRON solar street light, kindly adhere to the following guidelines:

- **Handling:** Handle with care. Avoid dropping the product or placing heavy items on it.
- **Exposure:** Keep the product away from direct immersion in water. Ensure the solar panel is positioned away from the shadows of trees, buildings, etc. to maximize its efficiency.
- **Cleaning:** Avoid using cleaners that contain ammonia, benzene, or abrasive materials, as they can damage the product's surface.
- **Battery Maintenance:** For prolonged storage periods, recharge the batteries every 6 months to maintain their lifespan.
- **Parts Replacement:** Only use authentic NATRON replacement parts. Do not substitute with parts from other suppliers as it might compromise the system's integrity and damage other components.

2. OPERATING AND STORAGE TEMPERATURE

For the NATRON solar street light to function optimally, it's crucial to consider the temperature ranges for both operation and charging:

- **Discharge Temperature:** The product is designed to discharge effectively within a temperature range of -4 °F to 140 °F (-20 °C to 70 °C).
- **Recharge Temperature:** Ensure recharging is done within a temperature window of 32 °F to 140 °F (0 °C to 70 °C).
- **Safety Protocols:** The built-in controller has a protection mechanism. If the temperature goes below -2 °F (-10 °C) or exceeds 140 °F (60 °C), it will automatically halt charging to safeguard the battery. To guarantee the longevity and performance of your NATRON, refrain from installing it in areas where extreme temperature conditions surpass these limits.

3. INSTALLATION LOCATION

Ensuring the correct location for your NATRON solar light is crucial for its optimal operation. Adhering to the following guidelines will not only enhance its efficiency but also prolong its lifespan:

- **Sunlight Dependency:** The NATRON system relies on sunlight to function. Make sure to select a model that matches the radiance or peak sun hours of your installation site. In regions with limited sunlight or after consecutive rainy days, the NATRON might operate for shorter durations or may not activate at all.
- **Solar Panel Orientation:** Position the NATRON's solar panel directly towards the sun to harness maximum solar energy. Avoid potential obstructions like trees or buildings that can cast shadows on the panel. Shadows can impede the battery's charging process and diminish the solar panel's efficiency, thereby affecting the unit's operational hours and overall battery life.

For optimal panel direction and angle, don't hesitate to seek guidance. We're always here to assist.

NOTE: The NATRON's internal components boast an IP65 rating, ensuring they are waterproof and ready to stand up to challenging conditions. The luminaire's designed holes and slits serve dual purposes

– facilitating heat dissipation and allowing for drainage. Moreover, its metal parts are crafted from anodized, rust-proof aluminum, capable of enduring both high temperatures and humid weather with ease.



NATRON

Solar LED Street Light 40W/30W

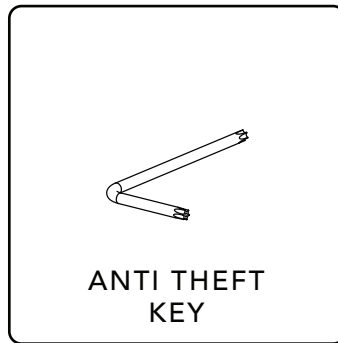
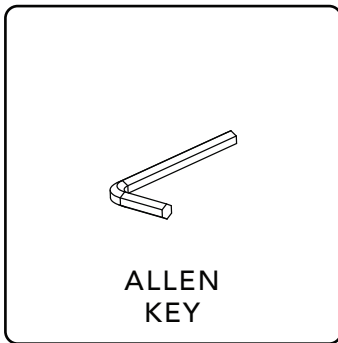
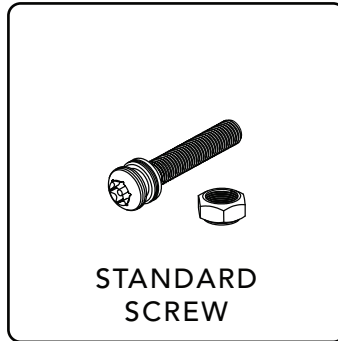

ANTI-THEFT TOOLS:

ENSURES THE NATRON REMAINS SECURELY IN PLACE AND REDUCES THE RISK OF UNAUTHORIZED REMOVAL

In the illustration provided, you can see an exploded view of all the key components of the NATRON.

For ease of installation, only the LED Arm, LED Fixture, and Spigot need to be attached. The rest of the NATRON comes pre-assembled, making it arguably the most straightforward solar street light to set up.

1. Solar Panel: Captures sunlight and converts it to electricity.
2. Solar Panel Support: Provides stability and holds the solar panel in place.
3. Aluminium Casing with LIFEPO4 Battery: A durable case housing the high-performance lithium iron phosphate (LIFEPO4) battery.
4. Spigot: Connects and secures the entire unit to its mounting.
5. LED Arm Support: Designed to hold the LED fixture securely.
6. LED Fixture: Main source of light output.

STEP 1

Carefully insert the LED cable through the LED Arm. Once positioned, tighten the LED fixture to the spigot on the arm.

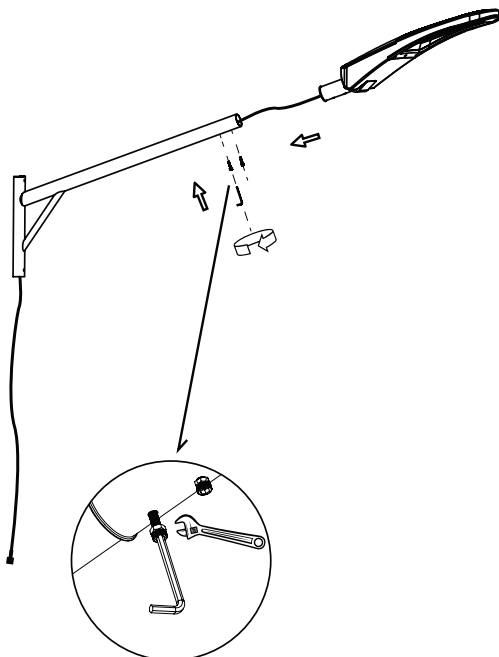

STEP 2

Position the base of the LED arm onto the pole. Ensure it's securely tightened. Guide the LED cable to exit from the top end of the pole.

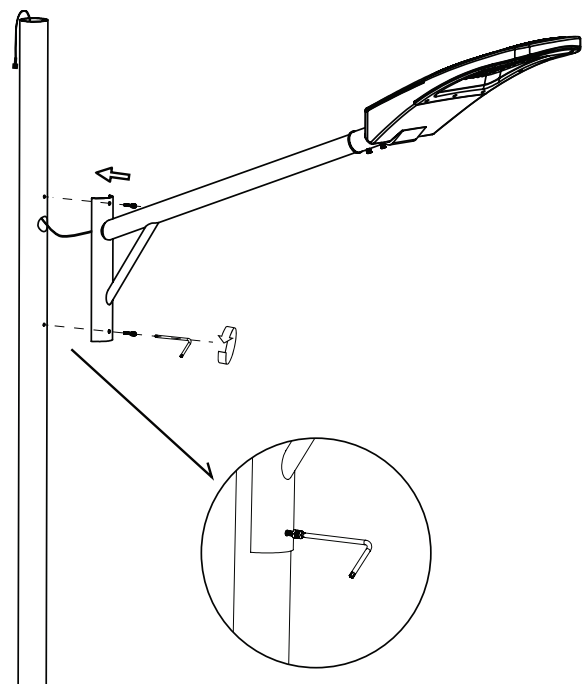

STEP 3

Using the provided tools, carefully remove the pre-installed screw from the solar panel support.

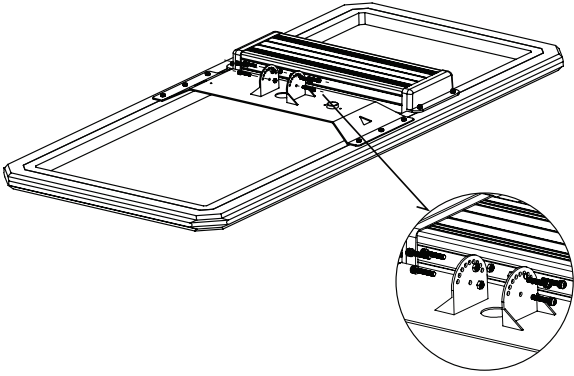

STEP 4.1

Using the provided tools, carefully remove the pre-installed screw from the solar panel support.

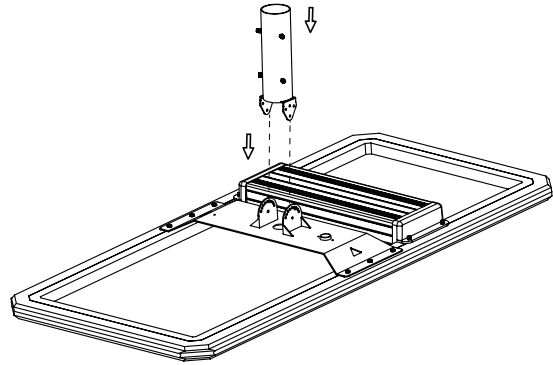

STEP 4.2

Begin by fitting the Spigot to the solar panel support. Initially, slightly fasten them together using the main central screw. (Final tightening will come later.)

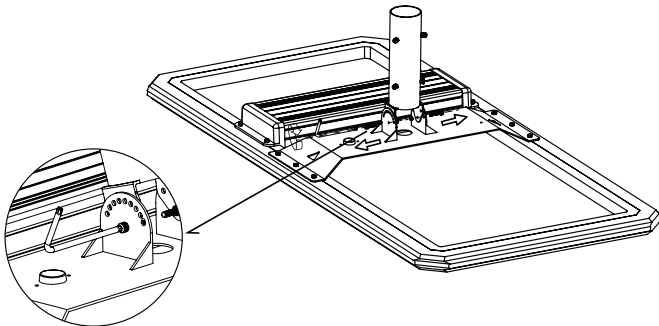

STEP 4.3

Attach the Spigot to the Solar panel using the screws you removed in Step 3. At this stage, you can choose the desired angle for your panel.

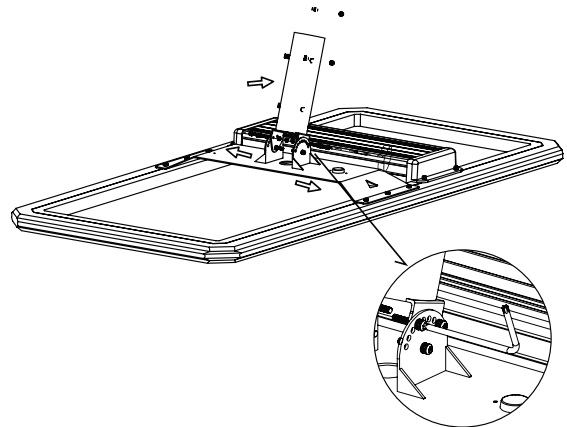

NOTE: For the most efficient performance of your NATRON, it's essential to adjust both the orientation and tilt based on your geographical location. The NATRON provides four different tilt options. If uncertain about the optimal position, please reach out to us or your reseller for guidance.

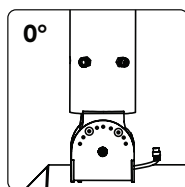

Holes 3 & 7

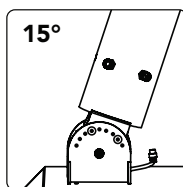

Holes 2 & 6

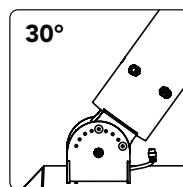

Holes 1 & 5

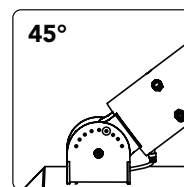

Hole 4

NATRON

Solar LED Street Light 40W/30W

STEP 5

Position the Solar panel over the pole, ensuring that the LED cable is threaded through the hole located in the upper part of the Spigot.

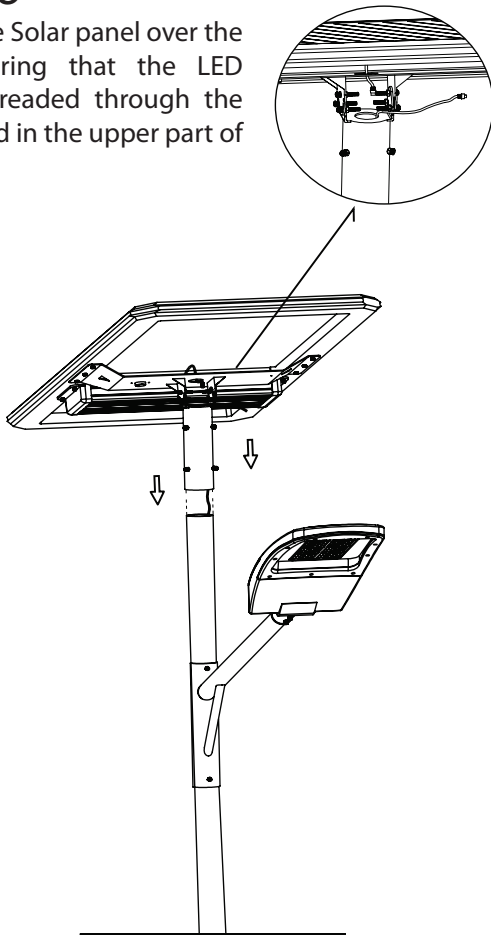

STEP 6

Using the supplied tools, securely tighten the Spigot to the pole.

NOTE: It's imperative to select the right orientation for optimal solar capture. In the Southern Hemisphere: Face the panel North. In the Northern Hemisphere: Face the panel South. Near the Equator: Opt for the smallest tilt angle possible.

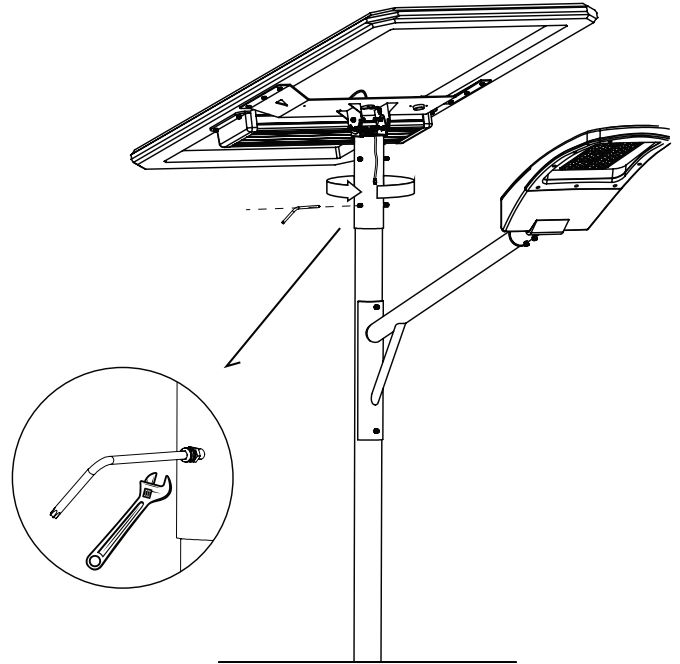

STEP 7

Carefully connect the two waterproof connectors labeled "LED." After ensuring a secure connection, press the "Switch On" button to activate the system.

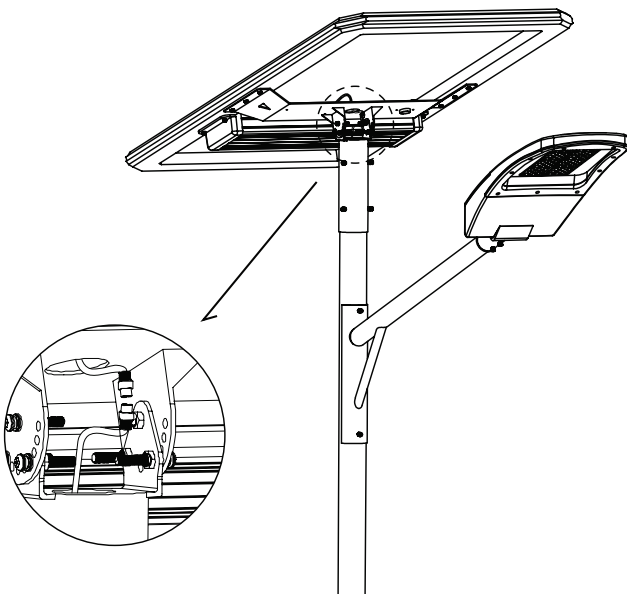

INSTALLATION COMPLETE!

Your NATRON system is now set up and operational. It is designed to function automatically, turning on at night and switching off at dawn. If the installation has been successful, you will notice a diode either slowly blinking or remaining steady on the movement sensor.

Should you have any further questions or require assistance, please don't hesitate to reach out to your reseller or directly to Beyond Solar. We're here to help!

DIMENSIONS

SOLAR PANEL & LED
All dimensions are in inches

