

www.sur-ron.com



STORM BEE
ELECTRIC MOTORCYCLES
OWNER'S MANUAL

Manufacturer: CHONGQING QIULONG TECHNOLOGY CO., LTD

Address: NO. 29, NO. 2 ZHICAI VILLAGE, QIEZIXI STREET, DADUKOU DISTRICT, CHONGQING, CHINA

Post Code: 400082

Tel: +86-23-68905603

Version: YS1A-NA-V1.0

This manual contains the most current product information available at the time of printing, your motorcycle may look and setup differ from the information supplied in this owner's manual. Please visit our website for updates and additional information about your motorcycle. This manual will provide you a better understanding of your electric motorcycle. Please take your time to read this manual carefully and all safety labels before riding.

Introduction

Congratulations on your choice to purchase the Surron Storm Bee motorcycle.

When you own a Storm Bee, you are part of a worldwide family of users who believe in Surron's company mission for redefining and building high quality new energy personal mobility in order to explore a revolutionary vehicle-marking philosophy by blending transportation and life.

Your Storm Bee is a high-performance off-road motorcycle that adopts the latest technology and is intended for off-road use only.

Be aware that off-road racing is a physically demanding sport that requires more than just a fine motorcycle. To do well, you must be in excellent physical condition and be a skillful rider. For the best results, work diligently on your physical conditioning and practice frequently.

Before riding, take time to get acquainted with your Storm Bee and how it works. To protect your investment, we urge you to take responsibility for

keeping your Storm Bee well maintained. Scheduled service is a must, of course. But it's just as important as to observe the break-in guidelines, and preform all the pre-ride and other periodic checks detailed in this manual.

You should also read the owner's manual before your ride., which is full of facts, instructions, safety information, and helpful tips. To make it easy to use, the manual contains a table of contents, a detailed list of topics at the beginning of each section.

If you have any questions, or if you ever need a special service or repairs, remember that your dealer knows your Storm Bee best and is dedicated to your complete satisfaction, so please reach out to the local authorized Surron dealer.

WARNING: This product can expose you to chemicals, including lead and BPA, which are known to the State of California to cause cancer or birth defects or other reproductive harm. For more information, go to www.p65Warnings.ca.gov.

Happy riding!

A B O U T T H I S M A N U A L

STORM BEE E NA :

Headlight

Off-road tire (21-inch diameter front and 18-inch diameter rear)

Riding tips for maximum range

Range varies in Storm Bee electric motorcycles similarly to how it varies in gasoline motorcycles. The range variety of Storm Bee electric motorcycles comes from the riding application after each full charge. In addition to riding habits, energy consumption is also affected by environmental conditions (such as extreme cold or hot weather, riding on steep soft road, etc.). To achieve the maximum range with a single charge, please pay attention to reduce the maximum speed, less sudden acceleration and maintain a constant speed to ensure the maximum range.

To reach the maximum range, please following the tips below:

- ① Avoid frequent and acute acceleration and braking.
- ② Under safe riding conditions, please reduce

the riding speed by using the throttle to decelerate instead of pulling the brake lever. When you're riding the Storm Bee, if the motorcycle is moving and the throttle is in the idle position, the energy regenerative brake will reduce the speed of the Storm Bee and converting the kinetic energy to charge the battery pack.

- ③ Maintain a correct tire pressure (Please refer to Recommended tire pressure table on page10.14).
- ④ Remove unnecessary goods and reduce load.
- ⑤ The maximum range in winter or summer could be slightly different.

In conclusion, the range can be estimated according to the above factors and your riding habits.

Note: The range will be reduced according to the various tough road conditions during off-road riding.

| | |
|--|-----|
| Introduction | 1.1 |
| Important Notice..... | 1.1 |
| Transporting..... | 1.2 |
| Safety Information | 2.1 |
| Safety Riding Requirement..... | 2.1 |
| Important Information..... | 2.2 |
| Location of Important Labels..... | 2.4 |
| Operation and Component Locations | 3.1 |
| Display and Indicator | 4.1 |
| Dashboard Overview..... | 4.1 |
| Feature Setting | 5.1 |
| Dashboard Setting..... | 5.1 |
| System Feature Setting..... | 5.2 |
| Feature Introduction | 6.1 |
| Handlebar Controls..... | 6.1 |
| Riding Mode Switch..... | 6.3 |

| | |
|---|------|
| Parking Brake Operation..... | 6.4 |
| Battery Pack Removal..... | 6.5 |
| Battery Pack Installation..... | 6.6 |
| Starting and Operating | 7.1 |
| Check before Riding..... | 7.1 |
| Key Switch/ Steering Lock..... | 7.2 |
| Riding A Storm Bee Electric Motorcycle..... | 7.3 |
| Temperature Indicator..... | 7.4 |
| Front Fork Adjustment..... | 7.5 |
| Rear Shock Adjustment..... | 7.6 |
| Power Management | 8.1 |
| Battery Pack..... | 8.1 |
| Power Supply and Charging..... | 8.1 |
| Power system Management | 9.1 |
| Power System..... | 9.1 |
| Maintaining Your Motorcycle | 10.1 |
| Maintaining Your Motorcycle..... | 10.1 |
| Maintenance Item..... | 10.1 |

| | |
|--|-------------|
| Maintenance Records..... | 10.1 |
| Regular Maintenance..... | 10.1 |
| Maintenance Schedule..... | 10.2 |
| Torque Management..... | 10.4 |
| Battery Pack..... | 10.6 |
| Brake System..... | 10.6 |
| Liquid Cooling System..... | 10.9 |
| Reduction Gearbox..... | 10.12 |
| Suspension System | 10.13 |
| Wheels and Tires..... | 10.14 |
| Chain..... | 10.14 |
| Headlight Adjustment | 10.16 |
| Light Bulb Replacement..... | 10.17 |
| Motorcycle Cleaning..... | 10.17 |
| Long-term Storage..... | 10.18 |
| Storm Bee Electric Motorcycle Parts..... | 10.19 |
| Fuse..... | 10.20 |
| Electric Circuit Diagram..... | 10.22 |
| Troubleshooting..... | 11.1 |
| Storm Bee Troubleshooting..... | 11.1 |
| Temperature Precautions..... | 11.1 |
| Safety Interlock..... | 11.2 |

| | |
|--|-------------|
| Storm Bee Precautions..... | 11.3 |
| System Warning Message..... | 11.4 |
| Error Code Chart..... | 11.5 |
| Troubleshooting..... | 11.8 |
| Warranty and After-sales Information..... | 12.1 |
| How to Obtain Warranty Service..... | 12.1 |
| Reporting Safety Defects | 12.1 |
| Annex..... | 13.1 |
| Parameters List | 13.1 |

Introduction

IMPORTANT NOTICE

Congratulations and thank you for purchasing Surron Storm Bee electric motorcycle. We sincerely welcome you to the community of Surron electric motorcycle riders.

This manual is designed to provide you with a better understanding of the operation, maintenance requirements and troubleshooting of your electric motorcycle. Please take your time to read this manual carefully as well as all safety labels before riding. Please DO NOT use it until you understand the basic operation and features of the Storm Bee electric motorcycle.

You can also find this manual to download on our official website <http://www.sur-ron.com>. If there is any critical update, it will be released on the official website. Please visit our official website to get the latest version.

Please ensure that this manual stays with the motorcycle at all times, even when you resell it.

If you have any questions regarding the operation or maintenance of your motorcycle, please contact the after-sales service department of Surron at:

/// service@qiulongtech.com ///

WARNING

If the power supply is damaged or the charging system malfunctioned, please contact your authorized dealer designated by the manufacturer immediately for replacement or repair.

Introduction

TRANSPORTING

It is highly recommended that the electric motorcycle be firmly secured on the transport frame using ratchet straps while it is being transported. It is recommended that the soft straps must be used to reduce scratches or other damages.

It is recommended to fix the ratchet straps according to the points shown in the figure. The front two are tied to the handlebar and the back two are tied to the left and right swingarms. Please do not damage the chain or brake line when tied the straps. The tie down straps should be at a 45° angle from the motorcycle. Follow the manufacturer's instructions for the ratchet straps you are using.

If you use a truck or motorcycle trailer to transport your Storm Bee, we recommend that you follow these guidelines:

- 1、Use a loading ramp.
- 2、Drain the oil from the reduction gearbox into an approved oil container.
- 3、Secure the motorcycle in an upright position, using motorcycle tie-down straps. Avoid using rope,

which can loosen and allow the motorcycle to fall over.

To secure your Storm Bee, brace the front wheel against the front of the truck bed or trailer rail.

Attach the lower ends of two straps to the tie-down hooks on truck bed or trailer rail. Attach the upper ends of the straps to the handlebar (one on the right side, the other on the left), close to the fork.

Check that the tie-down straps do not contact any control cables or electrical wiring.

Tighten both straps until the front suspension is compressed about half-way. Too much pressure is unnecessary and could damage the fork seals. Use another tie-down strap to keep the rear of the motorcycle from moving.

We recommend that you do not transport your Storm Bee on its side. This can damage the motorcycle.



Safety Information

SAFETY/RIDING REQUIREMENT//

Your electric motorcycle can provide many years of service and pleasure if you take responsibility for your own safety and understand the challenges you can meet while riding. There is a lot you can do to protect yourself whilst riding. You will find many helpful recommendations throughout this manual. The following are a few that we consider to be most important.

2.1

Storm Bee is a high performance electric motorcycle and should be treated with extreme caution.

Proper safety gear, including a regional/national approved helmet, riding boots, goggles, gloves, and protective clothing should be worn while riding to reduce the risk of potential injury, whether you are practicing to improve your skills, or riding in competition. We highly recommend the use of full height motocross boots since the vast majority of motorcycle injuries are through leg and foot impact.

Read all warnings and instructions in this manual as well as all the safety labels before operating your electric motorcycle.

Never allow a guest to ride your electric motorcycle without proper instruction. Ensure you have the legal

qualification to ride the motorcycle before operation.

Never consume alcohol or drugs before operation of your electric motorcycle. Even one drink or drug can reduce your ability to respond to changing conditions, and your reaction time get worse with every additional drink or drug. So don't consume alcohol or drugs and ride, and don't let your friends or others drink and ride either.

People unwilling or unable to take responsibility for their actions should not use this motorcycle. You assume all responsibility while operating your motorcycle. The seller assumes no liability for misuse or operator negligence.

Your Storm Bee is designed for one operator only. Carrying a passenger can cause a crash in which you and others can be hurt.

Take time to get to know your Storm Bee. Because every motorcycle is unique, take time to become thoroughly familiar with how this one operates and responds to your commands before placing your machine, and yourself, in competition.

Learn and respect your limits. Never ride beyond your personal abilities or faster than conditions warrant. Remember that alcohol, drugs, illness and fatigue can reduce your ability to perform well and ride safely.

Safety Information

required for use on public roads. If you need to cross a paved or public road, get off and walk your motorcycle across.

Modifications to the motorcycle may render the motorcycle unsafe and may cause severe personal injury. The manufacturer cannot be held liable for non-approved modifications.

Be very careful when loading or adding accessories to your motorcycle. Large or heavy items may adversely affect the handling and performance of your motorcycle.

2.2

IMPORTANT/INFORMATION///

Several important operation considerations are listed below: Always turn the key switch A and motor stop switch B to the OFF position when not actively riding. It is extremely easy to forget that the motorcycle is still in standby mode because it is completely silent. An accident can occur if the motorcycle is left powered up while getting on or off the motorcycle.

Turn the motor stop switch B OFF when pushing or moving the motorcycle. Use the parking brake C when you are stopped on a ramp or steep hill. Do not hold partial throttle to keep the motorcycle stationary on a ramp or steep hill, it can trigger the locked rotor

Safety Information

protection which cause the motorcycle to slip back.

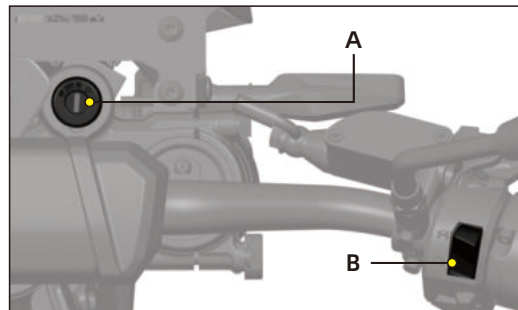

2.3

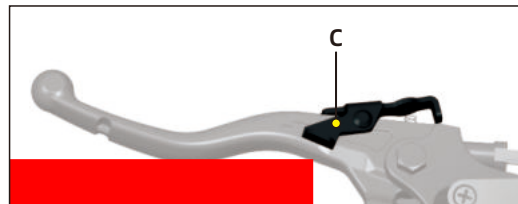

Please recharge the battery pack of your electric motorcycle after each use. Once fully charged, disconnect from AC power supply. Make sure that the charging is carried out in an open space or with monitoring. While unplugged with the key in the OFF position, the motorcycles electronic components will consume a small amount of power and the battery pack will drain extremely slowly. If you don't ride for an

extended period of time (30 days or more), you may need to charge the electric motorcycle for a few hours prior to your next ride.

The battery pack will be damaged if it is stored for a long time under low power.

CAUTION

Only charge the Storm Bee battery pack with the motorcycle's original charger or the manufacture approved accessory charger.

The battery pack does not require nor benefit from deep discharging. To get the most battery pack life, recharge the battery pack after each ride. Constantly leaving a battery pack in a deep discharging state will cause battery cell damage.

Failure to follow battery pack storage and charging instructions as described in this Manual may void the warranty of your Storm Bee electric motorcycle. These guidelines have been rigorously tested to ensure maximum battery pack efficiency and service.

Safety Information

LOCATION OF IMPORTANT LABELS///

Battery pack Warning Label B



High Voltage Warning Label A



Battery pack Warning Label C

MCU Label A

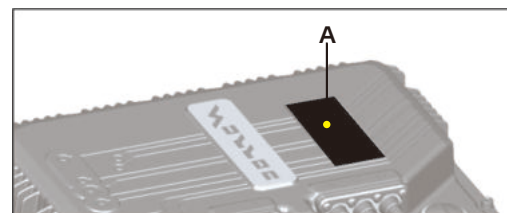

Frame Name plate A, The Vehicle Identification Number VIN Label B

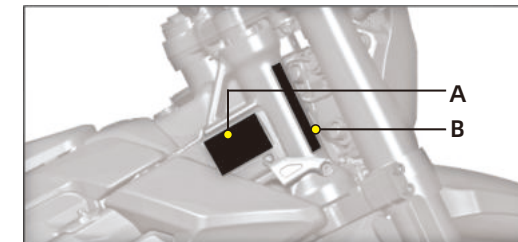

North America FCC\ICES certificate A

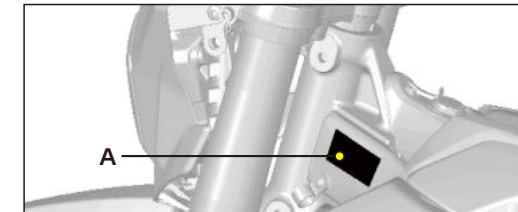

2.4

Motor Serial Number A

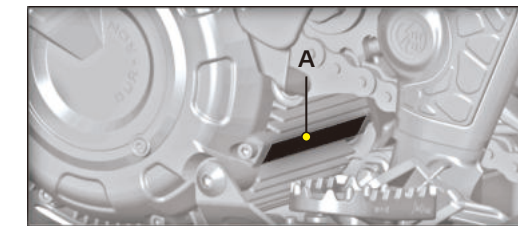

T-BOX (Telematics BOX)

SN Label



T-BOX (Telematics BOX)

SIM Label



VIN Label

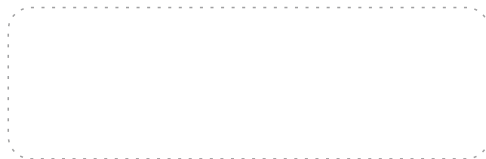

If your motorcycle has T-BOX installed, please go to the Download Center of Surron official website. Download the Surron APP, install and bind the device to use.



Scan this QR code to enter the Download Center.

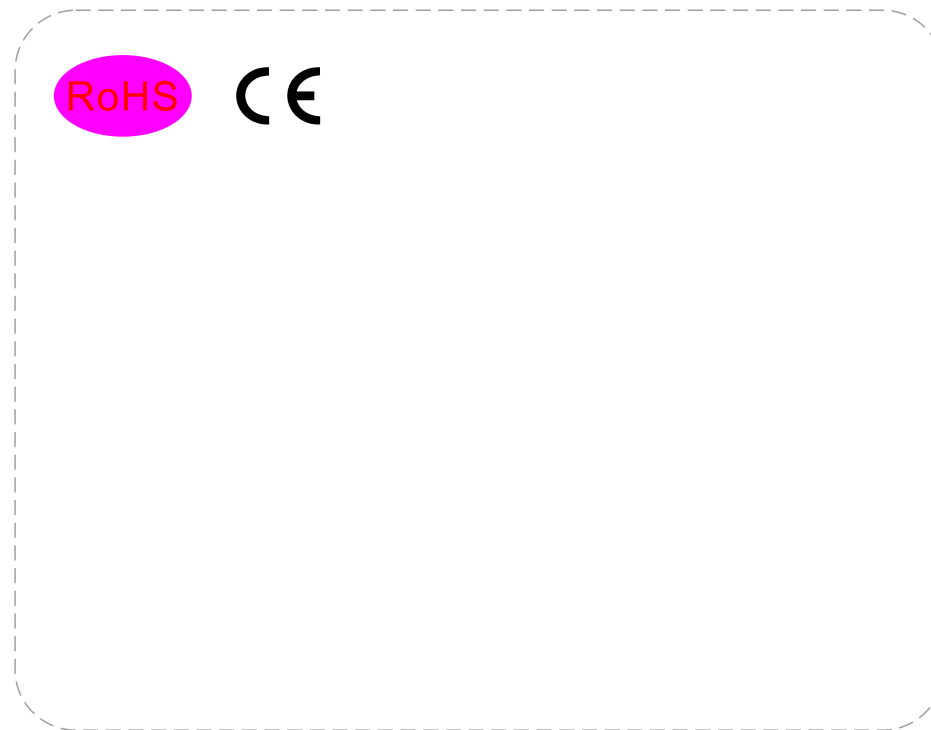

Operation and Component Locations

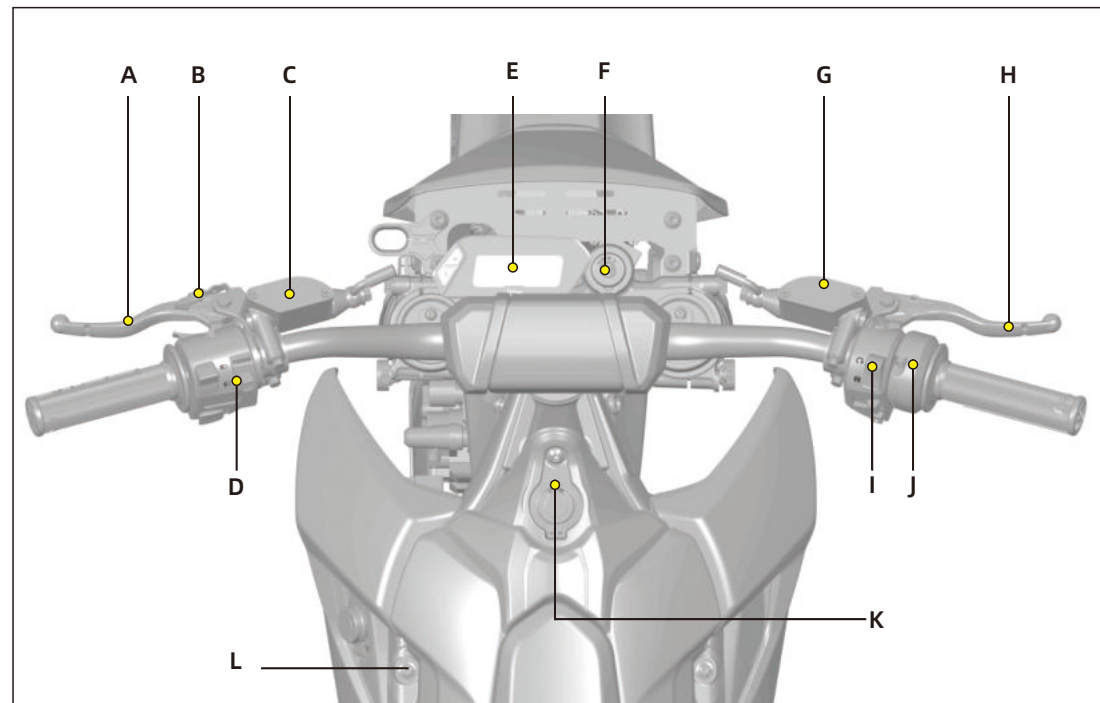

A. Rear Brake Lever

For description and operation, please refer to “Feature Introduction” , on page 6.1.

B. Parking Brake Lever

For description and operation, please refer to “Feature Introduction” , on page 6.1

C.Rear Brake Fluid Reservoir

For description and operation, please refer to “Maintaining Your Motorcycle” , on page 10.7 .

D. Left Handlebar Control

For description and operation, please refer to “Feature Introduction” , on page 6.1.

E. Dashboard

For description and operation, please refer to “Display and Indicator” , on page 4.1. and “Feature Setting” , on page 5.1.

F. Key Switch/Steering Lock

For description and operation, please refer to “Starting and Operating” , on page 7.2.

G. Front Brake Fluid Reservoir

For description and operation, please refer to “Maintaining Your Motorcycle” , on page 10.7.

H. Front Brake Lever

For description and operation, please refer to “Feature Introduction” , on page 6.3.

I. Right Handlebar Control

For description and operation, please refer to “Feature Introduction” , on page 6.2.

J. Throttle Grip

For description and operation, please refer to “Feature Introduction” , on page 6.3.

K. USB Port

5V 2.4A USB port.

L. Seat Installation Bolt

Fix the seat on the frame, please refer to “Feature Introduction” , on page 6.5.

Operation and Component Locations

Operation and Component Locations

3.3

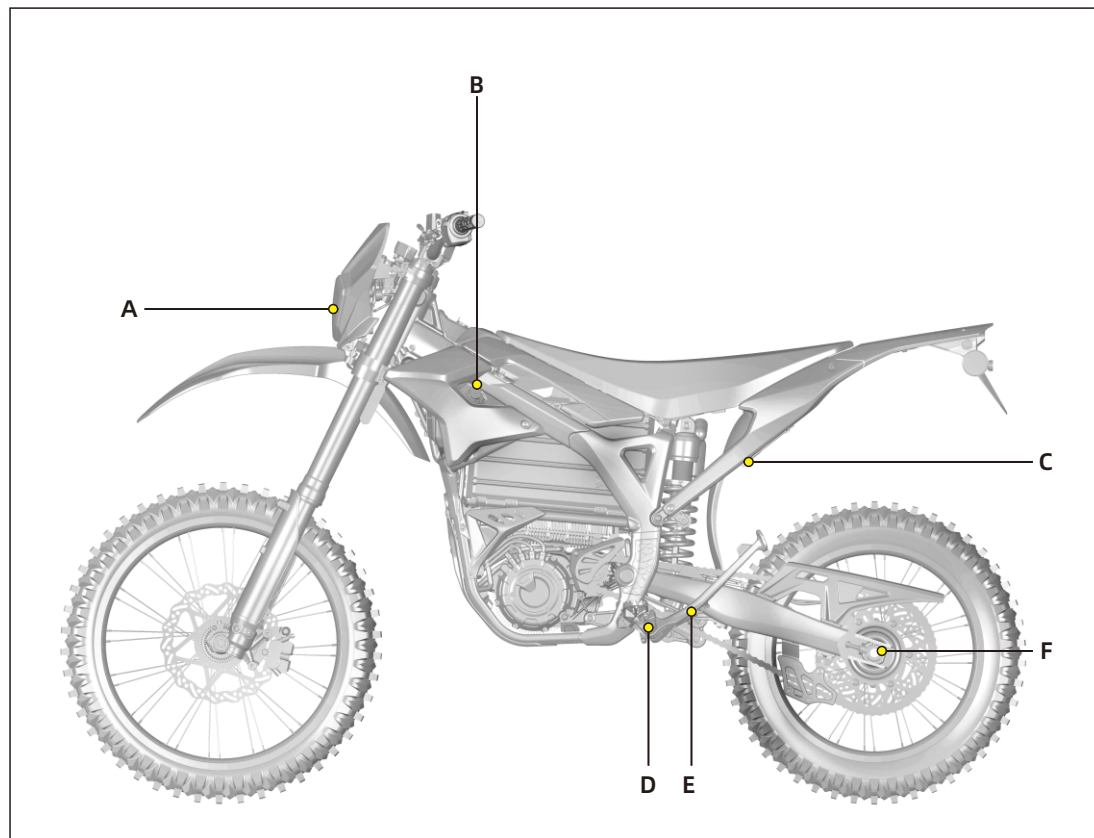

-FETCH LIGHT-飞起来-

A. Headlight

For headlight operation, please refer to “Feature Introduction” , on page 6.2.

For headlight replacement, please refer to “Maintaining Your Motorcycle” , on page 10.17.

For headlight alignment, please refer to “Maintaining Your Motorcycle” , on page 10.16.

B. Integrated Charging Port

For description and operation please refer to “Power Management” , on page 8.1.

C. Side Stand Strap

This strap is a safety feature that prevents the side stand drop down when riding causing you to lose control of the motorcycle and cause personal injury.

D. Side Stand Switch

This switch is a safety feature that prevents motorcycle operation when the side stand is down.

E. Chain Adjuster

Located on left and right side. please refer to “Maintaining Your Motorcycle” , on page 10.14.

F. Side Stand

The side stand supports the motorcycle when parked. The key switch should be in the OFF position when parked.

CAUTION

Park the motorcycle only on a flat firm surface, otherwise the motorcycle could fall over causing damage.

3.4

-FETCH LIGHT-飞起来-

Operation and Component Locations

3.5

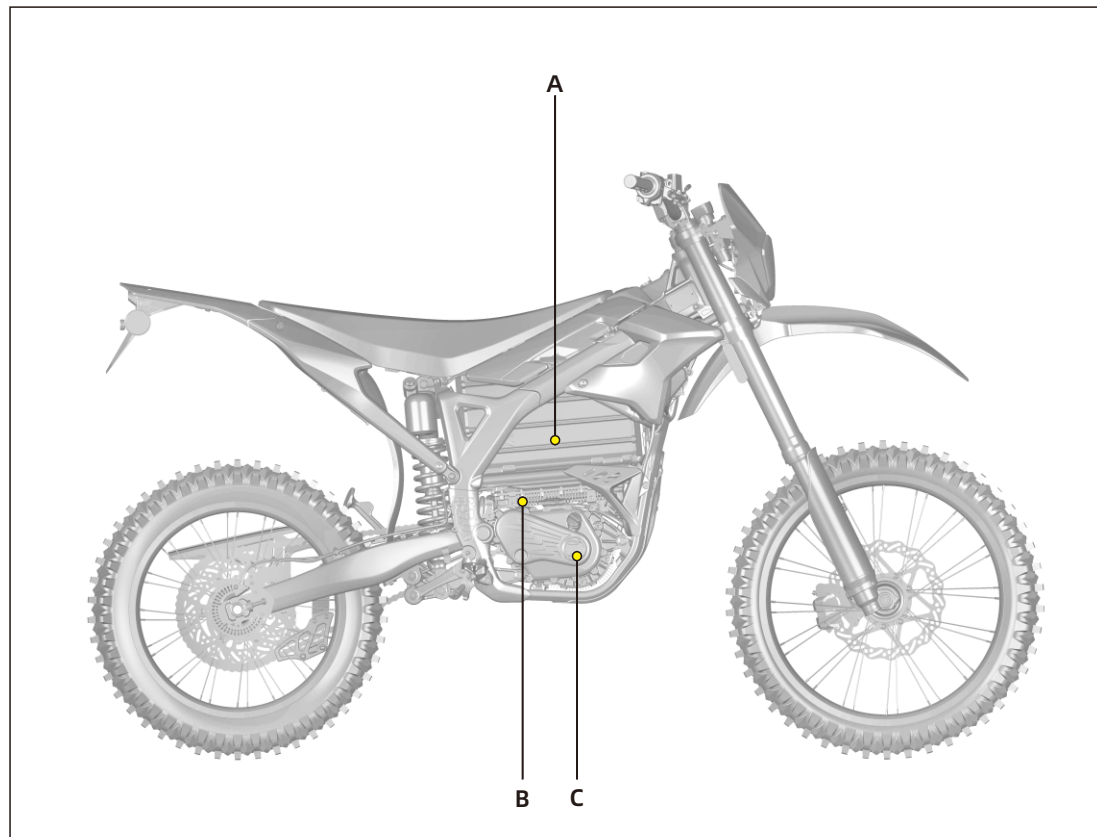

-FETCH LIGHT-飞起来-

Operation and Component Locations

3.6

A. Battery Pack

For description and operation, please refer to "Power Management" , on page 8.1.

B. MCU

For description and operation, please refer to "Power System Management" , on page 9.1.

C. Motor and Reduction Gearbox

For description and operation, please refer to "Power System Management" , on page 9.1.

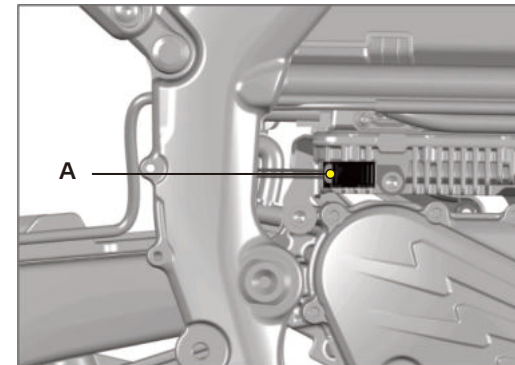

A. Temperature Sensor

Monitoring the temperature of the MCU, will activate the liquid-cooling system when necessary.

-FETCH LIGHT-飞起来-

Display and Indicator

DASHBOARD/OVERVIEW///

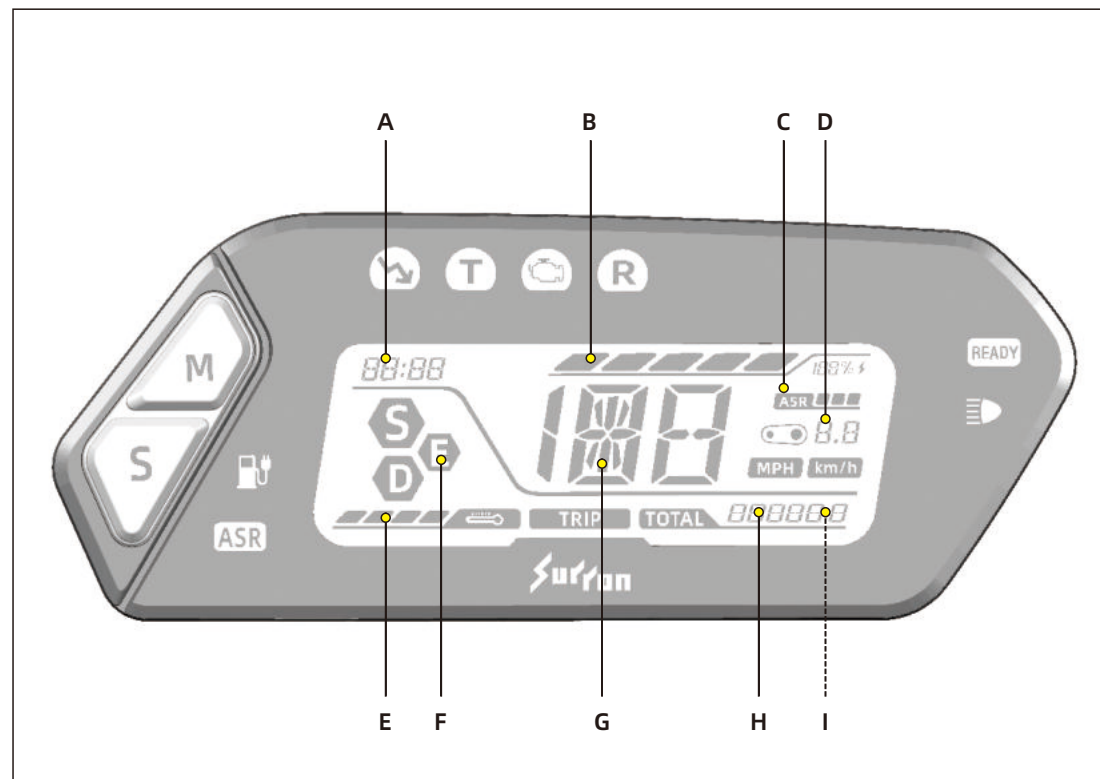

4.1

Display and Indicator

A. Clock

The clock displays time in 24-hour mode.

B. Charge Indicator

This indicator and readout display the amount of energy remaining in the battery pack similar to the fuel gauge on a gasoline powered motorcycle.

C. ASR Indicator

This indicator displays the current ASR level, disappear when ASR is turned OFF.

D. Transmission Ratio Display

It displays the current transmission ratio of Storm Bee electric motorcycle.

E. Temperature Indicator

The temperature indicator is on the left side of the LCD dashboard display, indicating the overall temperature of the motor, MCU and battery pack. When the temperature of one of these components exceeds the rated temperature limit, the temperature indicator will flash. For description and operation, please refer to "Starting and Operating" , on page 7.4.

F. Riding Mode

This area displays the riding mode (S, E, D) corresponding to the Riding mode of SPORT, ECO and DAILY (RAIN). The Riding mode switch is located on the right handlebar assembly.

For description and operation, please refer to "Feature Introduction" , on page 6.3.

G. Speedometer

The speedometer display in either kilometers per hour (km/h) or miles per hour (mph).

For description and operation, please refer to "Feature Setting" , on page 5.2.

H. Odometer

The odometer displays the total distance the motorcycle has been ridden in kilometers or miles.

I. Error Code Display

When the motorcycle fails, the corresponding error code will be displayed. For error code, please refer to "Troubleshooting" on page 11.5.

4.2

Display and Indicator

A. Low Power Indicator

Indicator the condition of the power system, remain flashing when power system enter low power mode.



illuminates when turbo mode is available. If the indicator is flashing slowly, turbo mode is in use. If the indicator is flashing rapidly, turbo mode is about to end.

B. TURBO Mode Indicator

This indicator shows the working state of turbo mode. The indicator will disappear when turbo mode is not available. The indicator



C. System Warning Indicator

The indicator illuminates when a fault has been detected. Please refer to "Troubleshooting" for detailed Error Code, on page 11.5.



D. Reverse Mode Indicator (R)

The indicator illuminates when reverse mode is ready to use; the indicator flash when the motorcycle is in reverse mode; the indicator disappears when the reverse mode is OFF.



E. Low Energy/Charging Indicator

When the energy remaining in the battery pack is low (SOC < 20%), the low energy indicator illuminates. If the energy remaining in the battery pack is very low (SOC < 5%), the indicator flashing. The indicator also flashing when the motorcycle is charging.



F. ASR (Traction Control System) Indicator

The ASR (Acceleration Slip Regulation) traction control feature is turned ON and OFF by the ASR button, and the ASR indicator illuminates when activate and dim if ASR is OFF. When the ASR indicator flashes, speed sensor or the ASR feature is malfunctioned. Please check whether the gap between the wheel speed sensor and the speed sensor ring is in the range of 0.03~0.05", and whether the wheel speed sensor is damaged.



Display and Indicator

G. Ready Indicator

The indicator illuminates mean the motorcycle is ready to go, if the throttle is twisted, the motorcycle will move.



H. High Beam Indicator

When the headlight high beam is ON, this indicator illuminates.



4.3

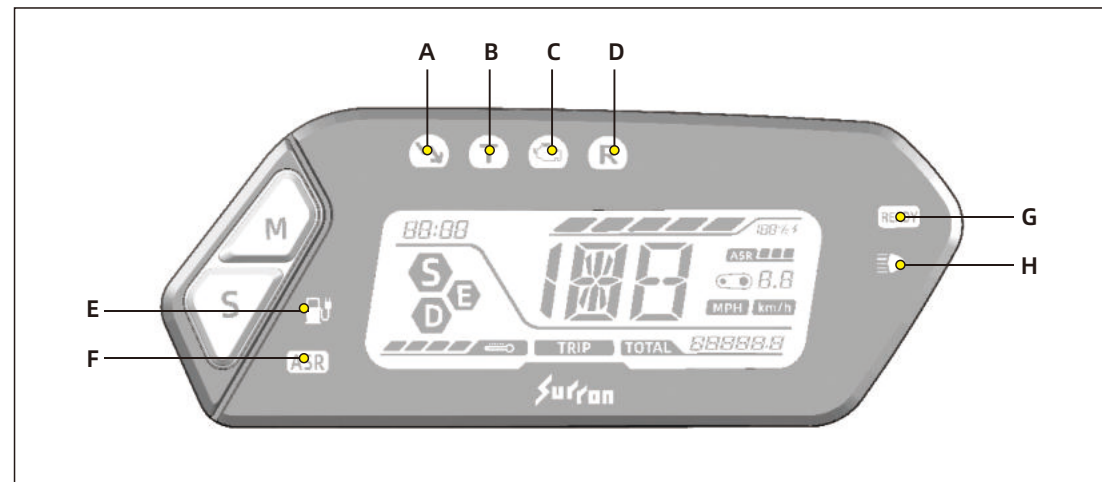

4.4

Feature Setting

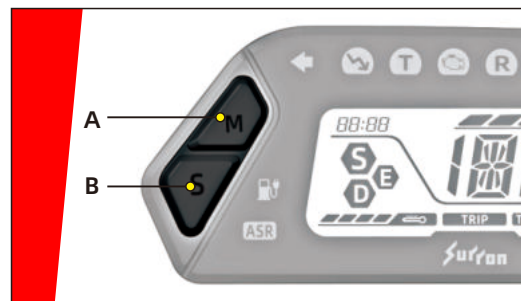

5.1

DASHBOARD/SETTING///

The features and displays on the dashboard can be customized to your personal preferences by using the A and B buttons combined with the C button on the Handlebar Control.

A. Mode Button (M)

By momentarily pressing or holding the M button you can reset fields and toggle through the menus and display options.

B. Select Button (S)

To select the corresponding feature by pressing S button when entering the feature menu.

C. Switch Setting Button R\S (Reverse and ASR)

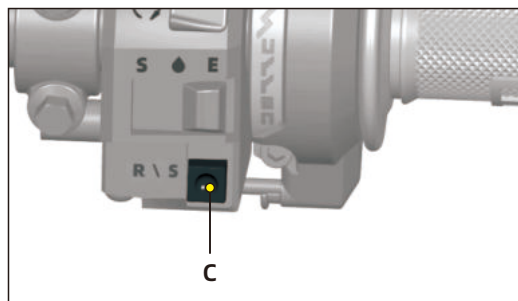

Quick Setting)

To set different feature by R\S button when entering the system feature mode (please refer to Feature Introduction" on page 5.3) . The R\S button can switch the ASR level during normal riding.

Display - Odometer

Select total

or trip mileage:

1. To select the display of total **TOTAL** or trip mileage

TRIP , momentarily press the M button when the dashboard in its normal operating mode and the speed is 0mph.

2. When Trip mileage displayed, and the motorcycle



Feature Setting

Press and hold the S button with the dashboard off and turn the key switch ON whilst still holding the SEL button for more than 2s with the dashboard in its normal operating. Then enter into the transmission ratio setting mode, and "  8.8" flashes. To adjust the transmission ratio by momentarily press M to decrease by 0.1, or S button to increase by 0.1. Press and hold M button for more than 2s to save the current setting.

ATTENTION

When the speed display on the speedometer is large than the actual speed, the transmission ratio can be reduced to meet actual speed; increase transmission ratio if speed display on the speedometer is less than the actual speed.

CAUTION

Please change the transmission ratio with cautious. (Stock original transmission ratio is 1.0)

5.2

speed is 0mph, the speedometer displays Top speed; the speedometer displays the current speed during riding.

Reset trip mileage and maximum speed:

To reset the trip mileage and maximum speed simultaneously by pressing and holding the M button for more than 2s in the trip mileage mode, when the dashboard in its normal operating mode and the speed is 0mph.

Unit Display - Speed



Select Miles per Hour (MPH) or Kilometer per Hour (km/h) :

1. When the motorcycle key switch is OFF, press and hold the M button and turn the key switch ON whilst still holding the M button for more than 2s, then select Miles per Hour (MPH) or Kilometer per Hour (km/h).

2. **MPH** is displayed when selecting Miles per Hour (MPH).

3. **km/h** is displayed when selecting Kilometer per Hour (km/h).

Display - Transmission ratio

Transmission ratio setting:



SYSTEM/FEATURE/SETTING///

Time Display

Clock Setting:

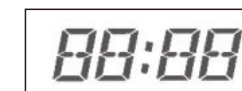

Feature Setting

Press and hold the M button for more than 2s when the motorcycle is switched ON, speed is 0km/h to enter the clock setting mode, the “Hours” will start to flash and ready to adjust; momentarily press M button again, the “Minutes” will start to flash and ready to adjust; momentarily press M one more time will quit clock setting mode.

When in “Hours” setting, press and release S button to increase the hour setting (momentarily press S button will increase 1 hour), momentarily press M button will save current setting and enter “Minutes” setting.

When in “Minutes” setting, press and release S button to increase the minute setting (momentarily press S button will increase 1 minute), momentarily press M button will save current setting and quit clock setting mode.

ASR (Traction Control System) Indicator



When you use the ASR button to select the certain ASR setting level, the ASR level will display as follow:

| | |
|--|---------------------------------|
| | non display(ASR turned OFF) |
| | display(ASR turned ON level 1) |
| | display(ASR turned ON level 2) |
| | display(ASR turned ON level 3) |

System Feature Mode Display

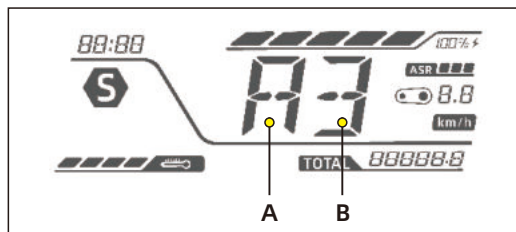

Note: Display one of the English letters in field A (Different English letters are displayed according to different feature modes).

Display one of the Numbers in field B (Different Numbers are displayed according to different feature modes).

System Feature Mode Setting:

When the motorcycle in its normal operating mode, press and hold M button and S button at the same time

over 2s to enter the system feature setting mode.

After enter the system feature setting mode:

1、Momentarily press R/S button in Right Handlebar Control: cycle through the current menu.

2、Press and hold R/S button in Right Handlebar Control: enter the setting menu of the currently selected feature menu or select the current setting and return to the feature menu.

3、Feature menu: always on.

4、Setting menu: flashing.

The features available are listed as follows:

①Level setting of brake energy regenerative feature (B0 B1 B2 B3 B4 B5) Factory default at B2 (feature is disabled in B0, and strengthens in turn from B1 to B5).

②Level setting of slide energy regenerative feature (E0 E1 E2 E3 E4 E5) Factory default at E3 (feature is disabled in E3, and strengthens in turn from E1 to E5).

③Level setting of ASR feature (A1 A2 A3) Factory default at A2 (feature strengthens in turn from A1 to A3).

④Setting of e-brake feature (P0 P1) Factory default at P0(feature is disabled in P0, and activated in P1) .

Feature Setting

⑤ Setting of tilt protection feature (C0 C1) Factory default C1(feature is disabled in C0, and activated in C1).

⑥ Beebox function (T0 T1) Factory default at T0 (feature is disabled in T0, and activated in T1).

⑦Throttle sensitivity adjustment feature (F1 F2 F3) Factory default at F1 (feature is strengthens in turn from F1 to F3, ONLY available in SPORT mode).

⑧ Charging power adjustment feature(U1 U2 U3) Factory default at U3 (U1 means the charging power is 450W; U2 is 800W; Maximum charging power U3 is 1300W)

⑨Exit System Feature Mode Setting (X) or No action in 10 seconds will exit System Feature Mode Setting.

WARNING

It is recommended to turn off the tilt protection in off road environment, to avoid the loss of power due to the triggering of tilt protection when performing some jump tricks.

Feature Introduction

HANDLEBAR CONTROLS

6.1

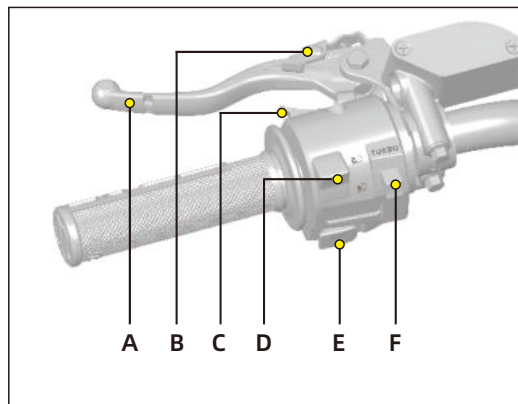

A. Rear Brake Lever

When you pull the lever backwards, it will control the rear brake system. When braking, the throttle should be in the idle position. The brake lights are also lit.

B. Parking Brake

When parking on a slope, apply the locking brake to prevent the motorcycle from slipping. For instructions and operations, please refer to page 6.4 of "Feature Introduction".

C. ASR (Traction Control System) Button

The Acceleration Slip Regulation (Traction Control System) can be adjusted by both the ASR button in the left-hand handle switch and the R/S button of the right-hand handlebar switch.

1、ASR button: located behind the left-hand handle control, trigger switch. When ASR is off.

①No action: ASR off

②Pressing: ASR is turned on and active in the previous ASR setting, release the button will disable the ASR.

③Quick press 3 times: ASR is turned on, and locked in active state; quick press 3 times again, ASR will be turned off.

2、Switch setting button R/S: Located in front of the right-hand handle control, trigger switch. When the dashboard in the normal condition, the R/S button can switch between ASR setting level.

① Short press once: display the current ASR setting level;

② Quick short press twice: The ASR setting will be leveled up and display on the dashboard; keep press R/S button will made the ASR level cyclically between display A1 ~ A3, please refer to page 5.3 for the specific

setting method.

D. Headlight High/Low Beam Switch

When the switch is pressed, the headlight changes from low beam to high beam. It remains in the selected position until it is switched back. When in the high beam position, the high beam indicator on the dashboard lights up.

E. Horn Button

When the key switch is in the ON position, the horn will make a sound when the button is pressed. The Storm Bee motorcycle is very quiet when riding, and the horn can be used to warn pedestrians or other motorists present.

F. Turbo Button

The Turbo button is the red button on the left handle switch. When the Storm Bee motorcycle is in the SPORT mode, press the Turbo button and the Storm Bee motorcycle will instantly output the maximum power. The Turbo mode is only activating short time period in the SPORT mode.

When the Storm Bee motorcycle is in the SPORT mode and met the operating conditions of Turbo mode, the Turbo mode indicator on the dashboard will illuminate.

Feature Introduction

6.2

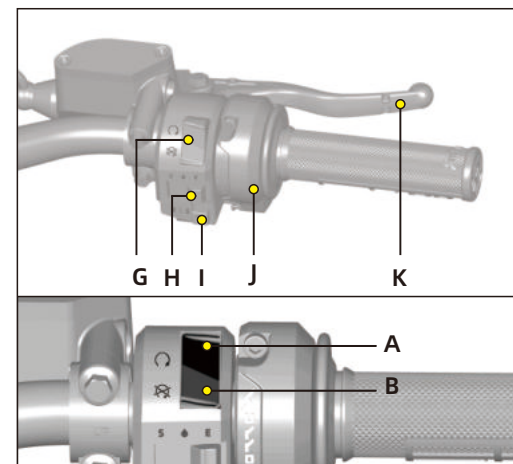

G. Motor Stop Switch

When the top A of the switch is pressed, it will cut off the power supply for operation signal. The MCU remains

Feature Introduction

in the state of no power output until the bottom B of the switch is pressed. The switch does not close all operation electrical circuits, only the operating of the motor.

H. Riding Mode Switch

For instructions and operations, please refer to page 6.3 of "Feature Introduction".

I. Reverse Mode\Switch Setting Button R\S

For instructions and operations of the function setting, please refer to page 5.1 of "Feature Setting".

reverse mode: When the throttle is in idle position, press and hold the R/S button and do not release it. The reverse indicator R on the dashboard will illuminate, and the Storm Bee motorcycle will enter the reverse mode. Only when the R/S button is released and the throttle is reset to idle position will exit the reverse mode and the forward gear mode will be functionally again.

The Storm Bee motorcycle will "shake" when enter or exit reverse mode.

J. Throttle Control

Twist the throttle handle counter-clockwise rotation to

energize the motor and accelerate the motorcycle.

The throttle sensitivity level can be adjusted in the System Feature Mode, please refer to page 5.3 for details.

K. Front Brake Lever

When you pull the lever backwards, it controls the front braking system. When braking, the throttle should be in the idle position. The brake lights are also lit.

RIDING/MODE/SWITCH///

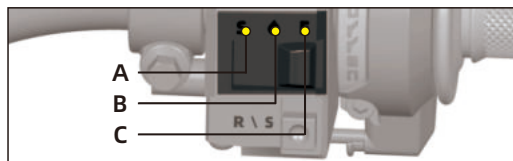

The Riding mode buttons include SPORT mode S, DAILY (rain) mode D and ECO mode E. You can switch between Riding mode while riding, and there will be notification on the dashboard.

A. SPORT Mode S

Slide this switch to the far left to enter the SPORT mode. This mode has strongest power output and acceleration ability. It is highly recommended using in trail or any

off-road condition, users only use this mode after familiarizing themselves with the Storm Bee motorcycle.

B. DAILY(Rain) Mode D

Slide this switch to the far left to enter the DAILY mode. In this mode, the power is reduced, and the ASR function is turned on and stay on by default, which can effectively prevent the Storm Bee motorcycle from slipping.

C. ECO Mode E

Slide this switch to the far left to enter the ECO mode. In this mode, the power and acceleration ability are much reduced, the Storm Bee motorcycle is much easier to ride and maximized the cruise range.

PARKING/BRAKE/OPERATION///



Storm Bee electric motorcycle is equipped a parking brake. When activated, the parking brake system will prevent the electric motorcycle from rolling forward or

Feature Introduction

backward.

A. Parking Brake On

Pull the rear brake lever, push the parking brake lever into the gap between the brake lever and the brake lever housing, and release the rear brake lever.

B. Parking Brake Off

Pull the rear brake lever, the parking brake lever will automatically pop out of the gap between the rear brake lever and the rear brake lever housing.

Feature Introduction

BATTERY PACK REMOVAL

1. Use a portable tool to remove the two mounting screws of the front support cover of the seat.
2. Push the seat forward first according to the arrow showing on the diagram, and then lift the seat upwards along the arrow to remove the seat.
3. Remove the communication connector B and the discharge plug C.
4. Remove the Battery bracket D from the bracket holder by using the special tool E and rotate them to the

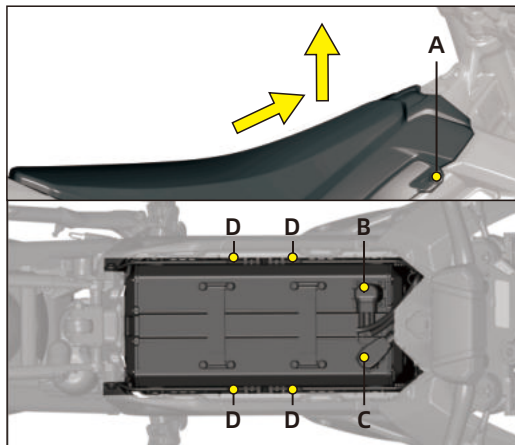

corresponding positions according to the arrow showing on the diagram.

5. Lift the battery pack up to remove the battery pack and put in the safe position.

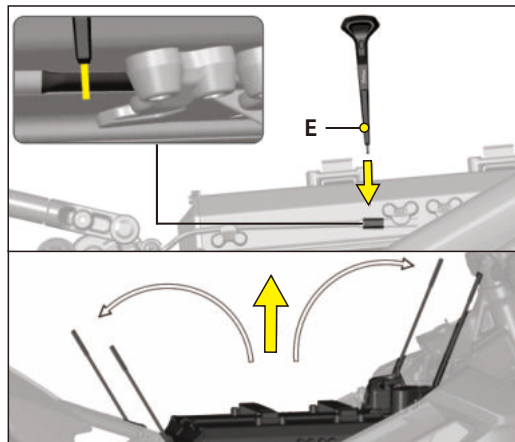

CAUTION

Remove or install of the battery pack will need special tool E (come with the motorcycle, inside of the tool bag).

Feature Introduction

BATTERY PACK INSTALLATION

1. Put the battery pack in the battery compartment.
2. Press the battery bracket D in to the bracket holder on the both side of the battery pack and fix the battery pack in the correct position.
3. Connect the discharge plug C back in first, then connect the communication connector B after.
4. Install the seat in according to the arrow showing on the diagram, first put the seat on the frame

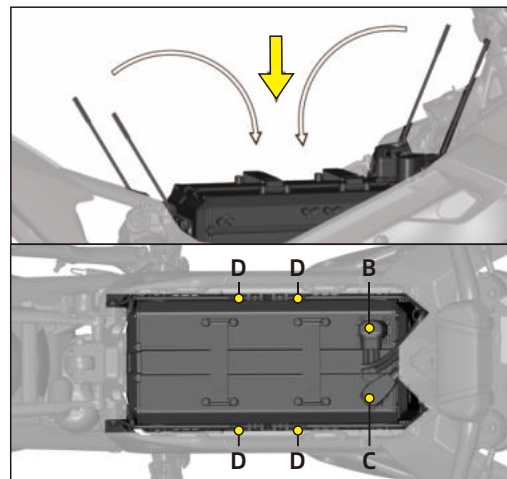

and push the seat backward along the arrow direction to fix the seat hook on the subframe.

5. Use a portable tool to tighten the two mounting screws A and fix the seat firmly in the correct position.

WARNING

Before removal and installation of the battery pack on the Storm Bee motorcycle, the key switch must be in the OFF position, so that the whole motorcycle is in no power condition. Do not change the installation steps of the communication connector and the discharge plug at will. As the battery pack are high-voltage components, the wrong installation steps may cause serious injury.

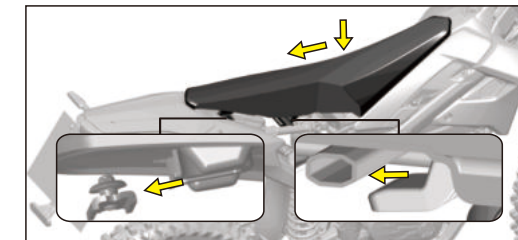

Starting and Operating

CHECK BEFORE RIDING

Before operating the electric motorcycle, please check the following item to ensure that the Storm Bee electric motorcycle is in operational condition.

Battery pack: Check that the battery level displayed on the battery pack or dashboard is sufficient to support your riding. We recommend you to full charge before use.

Chain: Check the chain tension and condition. Adjust or replace if necessary. Please refer to "Chain" on page 10.14.

WARNING

Unusual tire pressure is a common reason that cause of tire failure, and may cause severe tires issues or loss the control of the electric motorcycle, which may result in serious personal injury. Check the tires regularly to ensure proper tire condition.

Brake system: Pull the brake lever and push the motorcycle to see if the front and rear wheels are

locked. You should be able to lock the wheels completely by braking.

Throttle: When the key switch is in the off position, twist the throttle and release it to check whether the throttle is move smoothly and return to idle freely.

Tire : Check the tire pressure and tread depth of the tires.

Check the cold tire pressure, maintain the correct tire pressure, and check for damage and abnormal wear of the tire. As described on page 10.3, when the tread depth is reached the warning mark on the tire, please replace the tire immediately.

Electrical System: Check whether the headlights are functioning properly.

Cooling Liquid: Check the cooling liquid level, refill or change when needed. please refer to page 10.9 of "Liquid cooling system". Use high quality ethylene glycol antifreeze containing corrosion protection inhibitors specifically recommended for use in aluminum engines. Check the antifreeze container label.

Use only distilled water as a part of the cooling liquid solution. Water that is high in mineral content or salt

may be harmful to the aluminum engine.

Drive Chain : The service life of chain depends on proper lubrication and adjustment. Poor maintenance can cause premature wear or damage to the drive chain or sprockets.

When the motorcycle is ridden on unusually dusty or muddy tracks, more frequent maintenance will be necessary.

Before servicing your drive chain, turn the engine off and check that transmission is neutral.

Inspect the drive chain for damaged rollers, loose pins, dry or rusted links, kinked or binding link, excessive wear, etc.

KEY/SWITCH//STEERING/LOCK

This is a three-position key switch located above the front fork and in front of the handlebar. The switch positions are as follows (the off-road version equipped a two-position switch):

1. Steering lock A (off-road version does not have this function). 2. OFF B . 3. ON C .

The key should be removed from the electric motorcycle when parking to prevent motorcycle been stolen. The

Starting and Operating

key can be removed in the OFF or steering lock position.

Steering lock: Using a steering lock when parking can prevent unauthorized use and help prevent motorcycle been stolen.

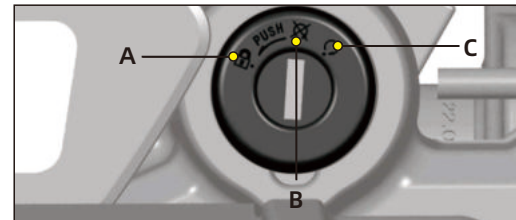

Operating the Steering lock:

1. Rotate the handlebar to the extreme left position.
2. With the key in the OFF position, press the key downward and then turn the key counterclockwise to the lock position.
3. Remove the key.

Unlock the steering lock:

1. Insert the key, press down and turn clockwise.

OFF position

This position is used to turn off the Storm Bee electric motorcycle, thereby disab all the electrical system.

Starting and Operating

ON position

This position is used to operate the Storm Bee electric motorcycle. The following visible instruments will light on when you turn the key switch ON:

Headlights turns on.

Dashboard display turn on.

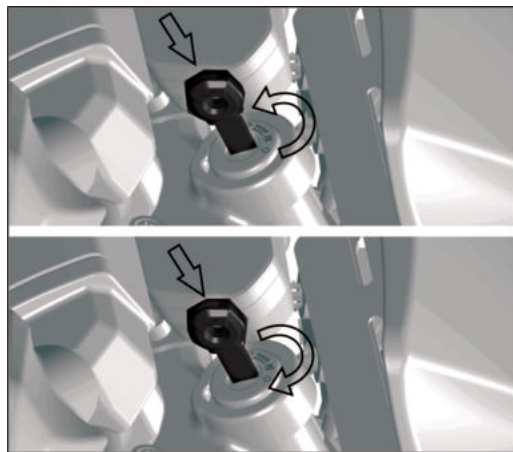

7.3

RIDING/A/STORM/BEE/ELECTRIC/// MOTORCYCLE///

Side Stand

The side stand is used to support your Storm Bee while parked. To operate, push the side stand down. Slowly lean your Storm Bee to the left until its weight rests on the side stand. Turn the handlebar fully to the left. Before riding, raise the side stand.

Starting

1. Turn the key switch to the ON position.
2. Confirm the battery percentage display on the dashboard.
3. Press the motor stop switch to the start position.
4. Gently squeeze the left rear brake lever to make sure that the parking brake is unlocked.
5. After confirming that there are no obstacles and passing vehicle in the surrounding area, retract the side stand, gently squeeze the brake lever to enter the READY mode, and the green READY light on the dashboard will light up, and twist throttle inward (counter clockwise) to increase the speed and riding.

Starting and Operating

Park the Storm Bee electric motorcycle

1. When the throttle is in the closed position, press the motor stop switch to the closed position. The switch can also be used to turn off the motor in an emergency.
2. Turn the key switch to the OFF position and remove the key, and keep it in a safe place.
3. Lock the parking brake to prevent the motorcycle from moving due to the gradient (it is recommended to use the parking brake when parking on flat ground and slope, this is a good parking habit).
4. After each ride, please check the power and charge the battery pack in time.

TEMPERATURE INDICATOR///

The electric motorcycle power system will generate heat, to keep the Storm Bee electric motorcycle continuous operation, the system combined air-cooled motor and liquid-cooling MCU. The Storm Bee electric motorcycle will self-monitoring the temperature of each component of the power system, displayed on the dashboard, to ensure the power system operating through a comprehensive multiple thermal management strategy.

Temperature indicator on the dashboard B, indicates

Braking

The brake levers are located on the left and right handlebars.

When you pull the right brake lever, it controls the front brake.

WARNING

Progressive use of the brakes and control of the operating force on the brake lever will gradually stop the electric motorcycle without locking the wheels. Your electric motorcycle is a powerful vehicle, so it is strongly recommended that you practice adequately, and familiar with all the safe emergency stop operation.

NOTE

When REGEN function and ebrake function are both turned ON, gently pull the brake lever, the power train will start REGEN brake. The higher the REGEN level is, the stronger the brake force will apply. (REGEN is only an assistance brake function.)

7.4

Starting and Operating

the power system temperature (battery pack, motor and MCU).

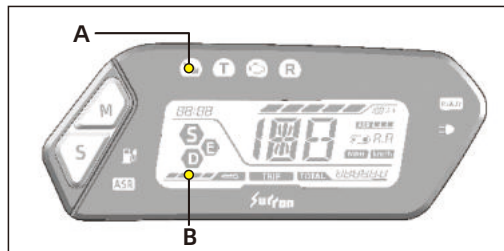

7.5

Continuous riding the electric motorcycle, the temperature indicator progress bar will gradually increase. When power system temperature is over the temperature limitation, the entire temperature indicator B will flash, and the orange system warning indicator A above the dashboard will also start flashing, the Storm Bee electric motorcycle will enter the temperature protection mode (power system output power will reduce).

FRONT/FORK/ADJUSTMENT

Compression damping

Use a flat-blade screwdriver to turn the screws A on the top of the left and right front fork to adjust the compression damping. The symbol "+" means

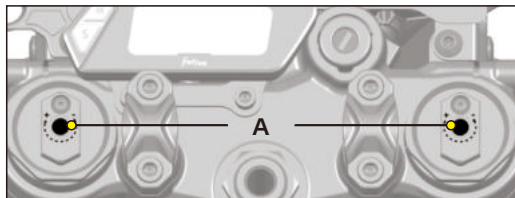

increasing compression damping, and the symbol "-" means reducing compression damping.

Turn the adjusting screw A clockwise in the "+" direction to increase the compression damping.

Turn the adjusting screw A counterclockwise in the "-" direction to reduce the compression damping.

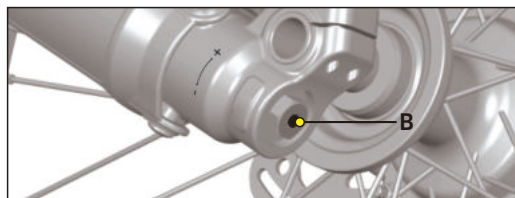

Rebound damping

Adjust the rebound damping by turning the screws B at the bottom of the left and right front fork with a flat-blade screwdriver. The symbol "+" means increasing rebound damping, and the symbol "-" means reducing rebound damping.

Starting and Operating

REAR/SHOCK/ADJUSTMENT

Compression adjustment



The compression adjustment screw A is located on the top right side of the rear shock absorber, using a screwdriver to adjust the compression. "+" is printed on the adjusting screw to indicate increasing compression damping and "-" indicates reducing compression damping.

Turn the adjusting screw A clockwise in the "+" direction to increase the compression damping.

Turn the adjusting screw A counterclockwise in the "-" direction to reduce the compression damping.

Rebound adjustment

The rebound adjustment screw B is located at the bottom right of the rear shock absorber using a screwdriver to adjust the rebound. "+" printed on the adjustment screw means increasing rebound damping,

Turn the rebound adjusting screw B clockwise in the "+" direction to reduce the rebound speed.

Turn the rebound adjusting screw B counterclockwise in the "-" direction to increase the rebound speed.

CAUTION

Try to keep the damping adjustment balanced.

The appearance of front fork in different brands may be different, please refer to the actual product.

When adjust the damping of the fork, make sure the setting is identical for both sides.

The damping and spring preload should be adjusted reasonably according to the road conditions and the weight of the rider.

Avoid adjusting the damping to the maximum limit value, otherwise the front fork may malfunction or even cause a crash.

7.6

Starting and Operating

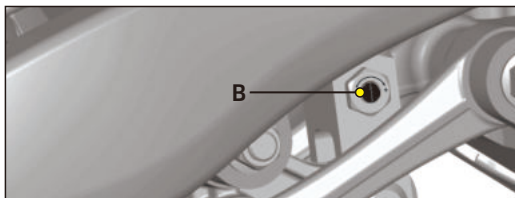

"-" means reducing rebound damping.

Turn the adjusting screw B clockwise in the "+" direction to reduce the rebound speed.

Turn the adjusting screw B counterclockwise in the "-" direction to increase the rebound speed.

NOTE

The appearance of rear shock absorber in different brands may be different, please refer to the actual product.

Rear shock preload adjustment

1. Using adjusting wrench to loosen the spring lock ring A.
2. Use an adjusting wrench to turn the adjusting ring B.

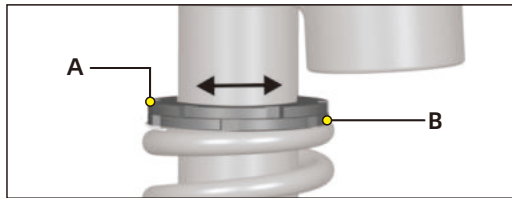

3. Rotate the adjusting ring B counterclockwise to reduce the preload on the spring and rotate the adjusting ring B clockwise to increase the preload of the spring.

4. Using adjusting wrench to tighten and lock the spring lock ring A.

CAUTION

The damping and spring preload should be adjusted reasonably according to the road conditions and the weight of the rider. Avoid adjusting the damping to the maximum limit value, otherwise the shock absorber may malfunction or even cause a crash.

Power Management

BATTERY/PACK////

The Storm Bee electric motorcycle uses high-performance and high rated lithium battery which can be used in the ambient temperature range of -4°F~131°F, the best working condition is when ambient temperature is between 50°F~86°F. Ambient temperature too low or too high will affect the battery pack performance and service life. Do not use it at temperatures beyond the allowable range, and do not charge the battery pack below 32°F.

The charge time of the battery pack is about 4h (input voltage AC190 ~ 250V) /5h (input voltage AC 95 ~ 125V) in normal ambient temperature.

When the ambient temperature is too low, the performance of the battery pack will be affected. It is normal to reduce the range a little, and the performance of the battery pack will automatically recover after the temperature rises back to working condition.

When battery pack not in use for a long time, please charge the battery to 60%~80% of the full battery capacity, and you will need to check the remaining battery percentage every month. Must recharge the battery pack to 60% ~ 80% of the full battery capacity if

the battery drops below 30%.

It is strictly forbidden to wash the battery pack with a high-pressure water pump, let alone immerse the battery pack in water. The wading of the whole motorcycle should not exceed the center of the wheel, otherwise it may cause water ingress in the battery pack, internal short circuit and permanent failure of the battery pack.

If water ingressed into battery pack or battery pack had other issues, it is strictly forbidden to charge the whole motorcycle or battery pack again. It may cause the risk of fire, combustion and explosion of the battery pack.

The battery pack is water resistant and sealed with a high voltage circuit inside. If the external structure is damaged this will reduce the water-resistant performance of the battery pack. If the water-resistant structure is damaged, please contact the after-sales service. It is strictly forbidden for customers to disassemble the battery pack, to avoid potential damage and serious danger.

POWER/SUPPLY/AND/CHARGING////

Before charging, please check whether the input voltage range of the charger is consistent with the grid voltage, AC 95 ~ 125V / 190 ~ 250V.

Power management

Before charging, please check whether the load power of AC power network socket can meet the power requirements of charger.

When charging, please connect the battery pack first, and then connect the AC power input plug. If you plug in the AC power first and then connect to the motorcycle battery pack, the charger can not charge normally.

You can directly plug the charger into the battery charging port A on the portside of the motorcycle or plug the charger into the charging socket B of the removed battery pack to charge.

The charger will turn off automatically when it is fully charged. Please disconnect the power supply of the charger and unplug the charging plug.

When charging, please put it in a safe place and beyond the reach of children.

Avoid using the battery pack when it has just reached full charge. It is recommended to let it cool down for 10

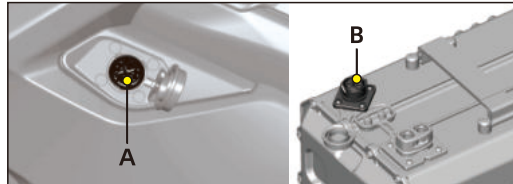

minutes or longer after it is fully charged.

It is forbidden to cover any object when charging. This charger is for indoor use. Please use it in a dry and well ventilated environment. After charging, please put the rubber cap of charging socket back on.

WARNING

Always charge the battery pack in a well-ventilated place and away from any fire hazard. If you want to charge the electric motorcycle outdoors, do not charging in the rain or humidity condition.

The battery pack can only be charged with a special charger supplied with the original motorcycle manufacturer or specified by the manufacturer. The use of unauthorized chargers or accessories may cause damage or failure of the battery pack, or even cause danger.

Do not charge the battery pack below 32°F, otherwise it will damage the battery pack. It

Power Management

can only be charge after the temperature of the battery pack rises back to above 32°F. The maximum allowable charging temperature inside the battery pack is 131°F. If the internal temperature of the battery pack exceeds this temperature, it can only be charged after cooling to below 131°F. If the battery pack is discharged rapidly due to heavy duty riding, the internal temperature of the battery pack may still be higher than 131°F even if the ambient temperature is low.

The battery pack is only allowed to return to normal temperature by itself. Do not use other methods to raise or lower the temperature of the battery pack.

The battery pack may not be able to charge immediately after high power output or high temperature operation. The battery pack should cool down for 30 minutes or longer before charging. The battery management

policy does not allow charging when the internal temperature is high, otherwise the battery life will be shortened.

SERIOUSWARNING

When you find the following situations, please stop charging immediately, disconnect the power supply, and do not use the electric motorcycle. Contact the after-sales service or send it to the maintenance office for maintenance as soon as possible.

The appearance of the battery pack is damaged.

Strange smell during charging.

The temperature of the battery pack or charger is too high and unable to cooling down by itself.

Charging cannot be complete for a long time. If the battery pack is on fire, please throw the battery pack into the water to prevent more damage.

POWER/SYSTEM///

The Storm Bee electric motorcycle power system include MCU, motor and a reduction gearbox.

WARNING

The customer is not allowed to disassemble the motor without permission, otherwise may cause the position sensor malfunction or damage the corresponding seal which can lead to motor malfunction.

There is gear oil inside the reduction gearbox. Please ensure that the gear oil level is in recommended position during the operation. Customers are not allowed to disassemble the reduction gearbox without permission.

The MCU is a precision high voltage electronic component. Incorrect wiring connection may cause damage to the MCU. Do not disassemble the MCU and cable without permission, otherwise it will cause electric shock, burn and other serious accidents.

The power system of the Storm Bee electric motorcycle must be repaired or replaced by a professional technician authorized by the manufacturer. Customers are not allowed to disassemble and modified the power system of the Storm Bee electric motorcycle without permission. Power cables had high current during operation, do make sure the cables are correctly and firmly connected, ensure that the torque and tightness of cable fastening bolts meet the recommended torque requirements and cable insulation also meet the requirements. Do not disassemble the power cable without any permission. The power system is 96V high voltage system and the power cable is in orange color. No matter the motorcycle is in operation, repair and maintenance or cleaning, it is necessary to ensure that the electric motorcycle is well isolated.

MAINTAINING YOUR MOTORCYCLE///

This section includes instruction on how to perform some important maintenance tasks. Some of the most important safety precautions follow. However, we cannot warn you of every conceivable hazard that can arise in performing maintenance. Only you can decide whether or not you should perform a given task.

Failure to properly follow maintenance instruction and precautions can cause you to be seriously hurt or killed. Always follow the procedures and precaution in this owner's manual.

Make sure the engine is off before you begin any maintenance or repairs. Otherwise, there would be injury from moving parts.

Read the instructions before you begin, and make sure you have the tools and skills required.

To help prevent the motorcycle from falling over, park it on a firm, level surface, using the side stand, an optional work stand or an optional work stand or a maintenance stand to provide support.

To reduce the possibility of a fire or explosion.

MAINTENANCE ITEM///

The following table lists the brake fluid, reduction gearbox oil and coolant to be maintained and replaced.

| Lubricants | Oil type | Volume |
|-----------------------|---------------------|--------|
| Braking fluid | DOT4 | / |
| Reduction gearbox oil | 10W-40 SG or higher | 300ml |
| Coolant | Ethylene glycol | 150ml |

MAINTENANCE RECORDS///

Follow the maintenance schedules on page 10.3.

REGULAR MAINTENANCE///

Keeping your electric motorcycle well maintained is absolutely essential to your safety. It's also a good way to get maximum performance of Storm Bee, avoid breakdowns, and have much more fun. The required maintenance schedule that follows, specifies how often you should have your electric motorcycle serviced and what items need attention. If you do not feel capable of performing a given task or need assistance, remember that your dealer knows your electric motorcycle best

Maintaining Your Motorcycle

and is fully equipped to maintain and repair it. Your warranty will be void if damage, malfunctions, or performance problems caused by the improper maintenance or repair of the electric motorcycle, installation of any parts or accessories not sold or approved by manufacturer.

The service intervals in this maintenance schedule are based on average riding conditions. Some items will need more frequent service if you ride in unusually wet or dusty areas. Consult your dealer for recommendations applicable to your individual needs and use. It is recommended that you maintain your electric motorcycle at least once every 6 months by an authorized dealer, regardless of the distance traveled.

MAINTENANCE/SCHEDULED///

To maintain the safety and reliability of your motorcycle, regular inspection and service is required as shown in the Maintenance Schedule that follows. The initial maintenance is vitally important and must not be neglected. Where time and mileage are listed, follow the interval that occurs first.

10.2

Maintaining Your Motorcycle

| Storm Bee Motorcycle Maintenance Schedule | | | | | | |
|---|------------|-----------------------|----------|-----------|-----------------------|--------------------|
| Check Item | Every ride | Initial 62miles | 310miles | 1240miles | 3100miles/ 6months | 6200miles/12months |
| Tire (front and rear) | ● | | | | | |
| Brake system (front and rear) | | ● | ● | ● | ● / ↻ | ● / ↻ |
| Drive chain | | ● | ● 滴 | ● 滴 | ● / ↻ | ● / ↻ |
| Battery voltage | ● | | | | | |
| Dashboard warning code | ● | | | | | |
| Reduction gearbox oil | | ● | | ● | | ● / ↻ |
| Front fork and rear shock | | ● | | ● | | ● / 🔧 |
| Brake fluid | | ● | | ● | | ● / ↻ |
| Coolant | ● | Check every 1860miles | | | | ↻ |
| Bearing | | ● | | ● | ● | ● / ↻ |
| Lights | ● | | | | | |
| Wheel Spokes | ● | 🔧 | | | 🔧 | 🔧 |

 check
  lubrication
  replace
  adjustment
  maintenance

10.3

Maintaining Your Motorcycle

TORQUE/MANAGEMENT///

Check regularly and tighten the following fasteners on the Storm Bee motorcycle according to the specified torque.

Caution:

Steering tube adjustment nut adjustment method:

1. Put the motorcycle on the support stand to make the front wheel off the ground

10.4

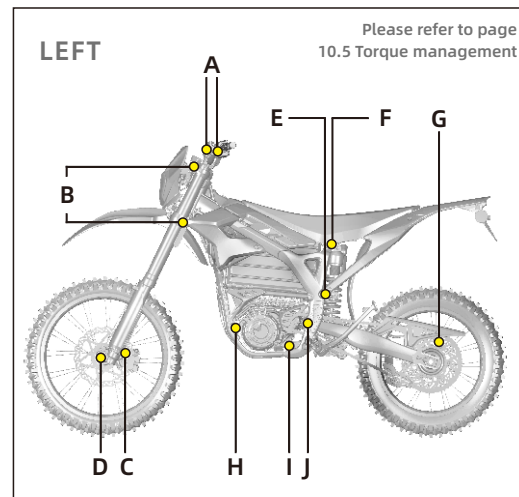

2. Loosen the steering tube locking bolt and the front fork mounting bolt on the upper triple clamp

3. Tighten the steering tube adjusting nut to 20N.m and then loosen it by 1/4 turn

4. Tighten the steering tube locking bolts and the front fork mounting bolts on the upper triple clamp

5. Check whether the handlebar turns smoothly or not and repeat the above operation if necessary.

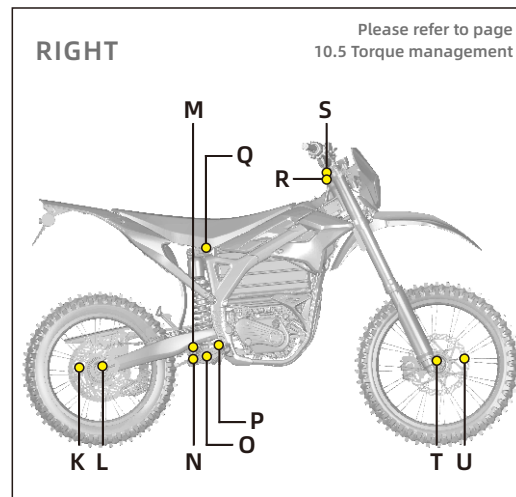

Maintaining Your Motorcycle

| | Item | Torque | Specifications | Instructions |
|---|--|--------|--|---|
| A | Handlebar installation screws | 30N.m | Hexagon socket M8*20 | \ |
| B | Front fork installation bolts | 28N.m | Hexagon socket M8*40 | \ |
| C | Front brake caliper installation bolts | 30N.m | Hexagon socket M8*35 | \ |
| D | Front axle bolts | 55N.m | Hexagon flange bolts -M14*1.5*20 | \ |
| E | Subframe installation screw bottom | 40N.m | hexagon cylindrical socket head screw M10*1.5*45 | \ |
| F | Subframe installation screw top | 28N.m | Hexagon socket pan head step screws M8*30 | Thread locker needed(e.g. KAFUTER K-0609 or similar products) |
| G | Rear sprocket installation screw | 28N.m | Hexagon socket countersunk M8*28 | |
| H | Motor front installation axle | 55N.m | Hexagon flange bolts M10*72 | \ |
| I | Motor rear installation axle | 55N.m | Hexagon flange bolts M10*108 | \ |
| J | Swingarm pivot | 130N.m | T-shaft - thread M16*1.5 | \ |
| K | Rear brake disc installation bolt | 10N.m | Hexagon socket countersunk M6*25 | Thread locker needed(e.g. KAFUTER K-0609 or similar products) |
| L | Rear wheel axle nut | 160N.m | Hexagon self-lock nut M22*1.5 | \ |
| M | Triangular cantilever axle top | 85N.m | Hexagon flange bolts M12*1.25-110 | \ |
| N | Triangular cantilever axle bottom | 85N.m | Hexagon flange bolts -M12*1.25-95 | \ |
| O | Rear shock axle bottom | 55N.m | Thread length M10*1.25-14 | \ |
| P | Link rod axle | 85N.m | Hexagon flange bolts M12*1.25-136 | \ |
| Q | Rear shock axle top | 55N.m | Thread length M10*1.25-16 | \ |
| R | Steering tube adjustment nut | \ | M30*8 | See previous note |
| S | Steering tube locking bolt | 65N.m | M26*8 | \ |
| T | Front axle locking nut | 28N.m | Hexagon socket M8*30 | \ |
| U | Front brake disc installation bolt | 10N.m | Hexagon socket countersunk M6*25 | Thread locker needed(e.g. KAFUTER K-0609 or similar products) |

10.5

BATTERY/PACK///

CAUTION

Battery packs are lithium-ion systems that do not require maintenance but need to be recharged from time to time. When not in use for a long time, please charge the battery pack to about 60% ~ 80% of the power storage. You will need to check the remaining power every 1 month. If the battery pack power drops below 30%, it should be recharged to 60% ~ 80%.

The battery pack should be kept away from high temperature environments. Do not store it in high temperature environment or under direct sunlight. When not used for a long time, please store the battery pack in an ambient temperature of 50°F ~ 86°F.

Only a service agent authorized by the manufacturer can be qualified to repair or dismantle the battery pack.

Dispose of used the battery packs please according to your local laws. The used battery pack is encouraged to be handled and recycled by professional company or organization and not discarded at will.

BRAKE/SYSTEM///

This chapter introduce how to maintain Storm Bee motorcycle brake system, which covers the front and rear brake pads as well as the parking brake, and recommends brake fluid volume and types for front and rear brake systems.

Brake system HCU

Only when the HCU (hydraulic control unit) is filled with brake fluid can the braking system operate efficiently. To fill the HCU with brake fluid, a vacuum pump and a filling machine are needed. Users need to bleed air from the HCU. This should be taken to the designated authorized dealer for the work to be carried out.

Brake fluid level check

Brake oil cup

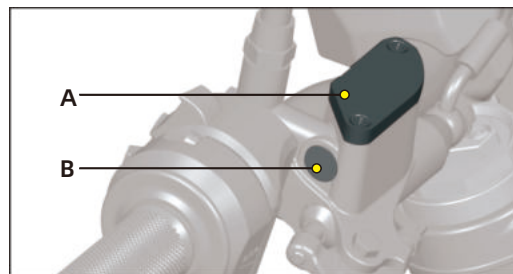

Check through the oil level inspection window B to observe the level of brake fluid. If the fluid level is significantly lower than one-third of the oil mirror, brake fluid must be added. Before opening the oil cup, please clean all dust or debris on the lid A.

A low fluid level may indicate worn brake pads or a leak in the hydraulic system. Check whether the brake pads are worn and/or the hydraulic system is leaking. Only use the new DOT 4 brake fluid in a sealed container.

The steps to add brake fluid are as follows:

1. Unscrew the two screws on the upper cover of the oil cup, remove the upper cover of the oil cup and the oil cup gasket.

2. Add new DOT 4 brake fluid.

3. Check the lid seal to make sure that there is no wear or damage, and the position is correct.

4. Install the upper cover screw of the oil cup (torque 4N.m).

CAUTION

Do not splash the brake fluid on the painted surface, it may damage the painted surface. Spilling brake fluid on plastic products can cause it to corrode. Before removing the cover, be sure to put an oil absorbent towel under the main cylinder reservoir.

WARNING

Before checking the liquid level, the Storm Bee electric motorcycle should be in a flat and upright state and the handlebars should be turned back to ensure that the oil cup is in a horizontal position. When adding new brake fluid, if the brake fluid overflows,

Maintaining Your Motorcycle

it should be removed immediately to prevent contamination of other parts.

Brake disc inspection

The thickness of the brake disc should be checked regularly. The minimum thickness is 3.0mm.

Brake pad inspection

The brake pads must be checked at the specified intervals in the maintenance scheduled, please refer to page 10.3. Check the remaining amount of brake pad material visually from the side of the brake caliper. If the thickness of the front brake pad is less than 1.5mm and the thickness of the rear brake pad is less than 1mm, replace the brake pads. If the metal part of the brake pad A is damaged, please replace the two brake pads immediately.

Brake pad replacement

It is recommended to check and run-in after replacing new brake pads or brake discs to ensure that the brake discs and brake pads adapt and match again. Correct running-in can improve the brake feel and reduce or eliminate brake noise.

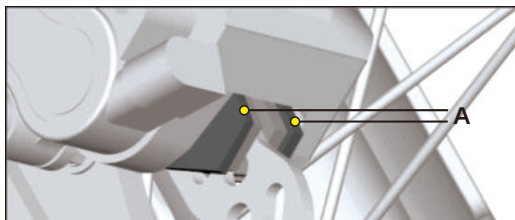

WARNING
When using a new brake system or new brake pads, the initial braking force may be too small. Please try to run-in the brake pads and brake discs at low speed and safety to ensure that the brake system provides normal braking force.

Parking brake

The Storm Bee electric motorcycle is equipped with a

parking brake. When the rear brake lever is in the depressed position, it will lock the rear wheels. Please check the parking brake regularly.

Parking brake inspection

1. Raise the Storm Bee electric motorcycle on the support bench to make the rear wheel off the ground.
2. Firmly hold the rear brake handle.
3. Push the rear brake parking paddles firmly into the parking position until it can no longer be pushed.
4. Release the rear brake handle, and then release the parking brake paddles.
5. The motorcycle can be parked successfully at this time.

CAUTION
Do not adjust the push rod adjustment screw on the handle at will, because this will cause the oil circuit to fail to refill normally after the brake is worn out.

WARNING
If the parking brake cannot effectively lock

Maintaining Your Motorcycle

the rear wheel, please contact an authorized dealer or after-sales service in time.

LIQUID/COOLING/SYSTEM////

The motorcycle has a liquid cooling system, please check and maintain according to the contents below.

CAUTION
The coolant will corrode the surface painting of the vehicle. When maintain the vehicle, pay attention to the surface painted parts and well protected those parts.
If it is contaminated, please wipe the coolant clean in time.
Do not use other liquids instead of special coolants. If already use other liquids instead, the liquid cooling system may be damaged, thereby reducing the working efficiency of the

Maintaining Your Motorcycle

10.10

liquid cooling system, and the liquid cooling system may not be protected against frost and corrosion.

WARNING

Do not open the lid of the liquid cooling system tank when the water pump and fan is operating. Coolant is toxic and can cause personal injury or death. If any personal taken coolant by accident, please seek medical help immediately. Please avoid excessive inhalation of coolant steam. If you accidentally inhale too much, please ventilate and breathe fresh air immediately; if the coolant gets into your eyes, immediately rinse with clean water and seek medical attention. Wash hands and soiled clothing thoroughly after servicing the vehicle. Keep children and pets away from coolant.

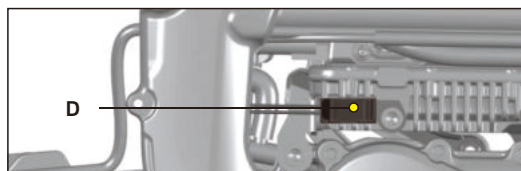
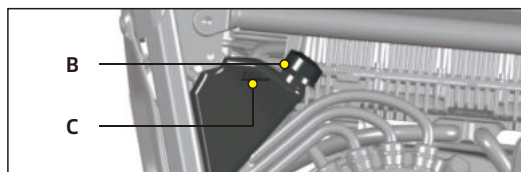
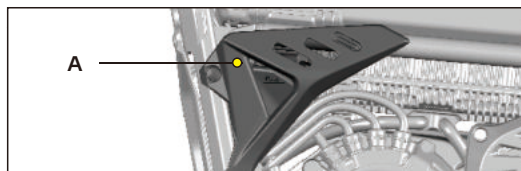

1. Support the vehicle with the side stand.
2. Please remove the left MCU Cover A of the controller and open the tank lid B, and add the coolant to the mark line C of the highest liquid level.
3. Turn on the key switch and start the liquid cooling system as follow:

Maintaining Your Motorcycle

10.11

a. Use about 1liter of boiling water, slowly pour it on the temperature sensor D, until the liquid cooling system starts to work.

b. Use a hair dryer to turn on the high temperature gear to centrally heat the temperature sensor D (need to isolate the surrounding cables) until the liquid cooling system starts to work.

4. Continue to fill the tank with the remaining coolant while the liquid cooling system is running.

5. Turn off the key switch and wait for 30 seconds before observing the liquid level position. The coolant should be above the mark line C of the highest liquid level.

6. Install the tank lid B and MCU Cover A back on.

Check coolant level

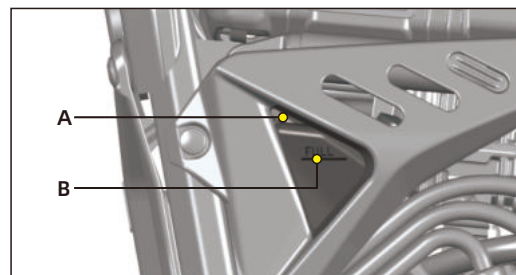

The coolant level should be checked frequently. Coolant level check steps are as follows:

1. Support the vehicle with the side stand when liquid cooling system is inactivated.
2. Check the position of the coolant level through the observation window A. At this time, the coolant level should be above the marking line B of the highest level of the tank.
3. If the coolant level cannot reach the marking line B, please add the coolant in time. Check above for the filling procedure.

Change the coolant

The coolant must be checked and replaced according to the times specified in the maintenance schedule table on page 10.3. Please contact your dealer to change coolant for you.

REDUCTION/GEARBOX///

The inspection and maintenance of the reduction gearbox should be carried out at the times specified in the maintenance schedule table on page 10.3.

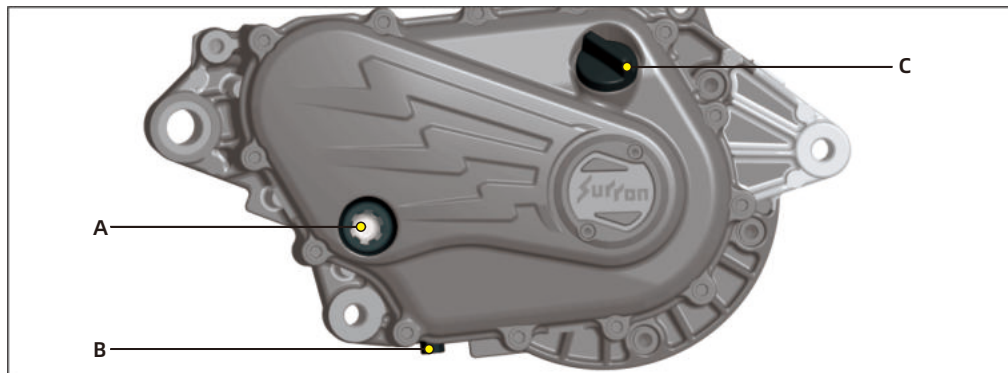

Inspection and replacement of Reduction gearbox oil

1. Support the vehicle upright and stand on the level ground when liquid cooling system is inactivated, observe the oil mirror A on the reduction gearbox, the normal liquid level should within the range of 1/2 to 2/3 of the mirror.

2. When replacing the gearbox oil, make sure turn off the key switch, and then open the oil drain bolt B to release the oil from the oil drain port until it drips discontinuously, then screw the bolt back in and tighten the oil drain bolt B.

3. Add new gear box oil from filling port C to make the liquid level reach 1/2 to 2/3 of the normal range of oil mirror A (about 300ml).

SUSPENSION/SYSTEM///

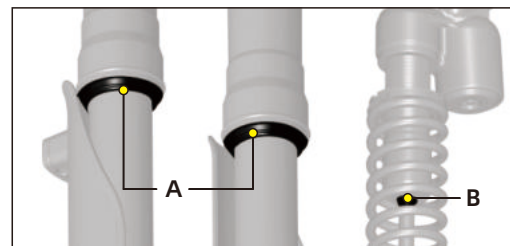

1. It is recommended to clean the surface of the shock absorber immediately after each ride, especially the mud and sand attached to the surface of the main tube. When cleaning with a high-pressure water gun, it is strictly forbidden to flush upwards facing the dust-proof seal A and B, as this will flush mud and sand into the oil seal and cause wear and oil leakage.

2. Do not use flammable or corrosive solvents to clean otherwise it will cause damage to the dust-proof oil seal. It is recommended to use a neutral detergent and a soft cotton cloth to assist in cleaning.

3. It is recommended to apply a layer of lubricating grease on the surface of the main pipe after cleaning to make the surface of the main pipe fully lubricated.

WARNING

The shock absorber contains high-pressure gas or liquid.

Do not try to tamper with or disassemble the shock absorber.

Please avoid impact, high temperature or open flame on the gas cylinder.

After riding the motorcycle, the shock absorber and the gas cylinder may be in a high temperature state, please avoid burns.

WARNING

Improper operation of the shock absorber may cause damage or serious personal injury.

For maintenance, please refer to the maintenance scheduled on page 10.3. Please refer to page 7.7 for adjustment.

Maintaining Your Motorcycle

WHEELS/AND/TIRES///

Check the wheels for the following conditions:

The rim is deformed or cracked.

There are impact marks on the rim.

Loose or deformed spokes.

There are cuts, cracks, cracks, or missing tread blocks in the tread or sidewall area.

Tire bulge.

The tire tread wears unevenly.

The height of the Tire line is uneven.

If you find any of the above conditions, please replace the wheels or tires immediately.

Tire pressure (Recommended tire pressure table)

| Status | Front wheel | Rear wheel |
|----------------|-------------|------------|
| Off-road tires | 230kPa | 225kPa |

Note: The recommended tire pressure range for off-road tires is 100 ~ 150 kPa for the motocross track or trail riding scenarios.

10.14

WARNING

Incorrect tire pressure is a common cause of tire failure. Long-term incorrect tire pressure may cause tire damage, separation of the tread or loss of control of the motorcycle resulting in serious personal injury.

Before each ride, check the tire pressure and adjust it to an appropriate air pressure level.

When the tire is cold, use an accurate pressure gauge to check the tire pressure.

CHAIN///

Please refer to the maintenance scheduled on page 10.3 for the inspection and maintenance of the chain.

1. Keep the chain and sprockets clean.
2. Check the chain wear, tightness, and lubrication.

① Use a support stand to raise the motorcycle so that the rear wheel hangs in the air. Move the chain up and down by hand and check whether the sag is within the recommended range: 1.38-1.77" .

Maintaining Your Motorcycle

② When adjusting, first loosen the rear wheel axle nut, and then adjust the left and right adjusting bolts to make the chain tightness within the recommended range.

③ Use an appropriate amount of chain oil or chain wax to lubricate the chain.

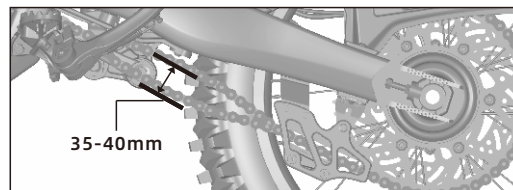

CAUTION

After adjustment, the left and right adjuster marks should be the same as the horizontal fork scale line.

Chain adjustment procedure

1. Use a support stand so that the rear wheel hangs in the air, turn off the motor stop switch and remove the key from the key switch.

2. Loosen the rear axle nut A.

3. Loosen the locknut C of the left and right adjusting bolts B.

4. Adjust the left and right adjusting bolts B equally until the chain is adjusted within the specified range.

5. Tighten the rear axle nut A.

6. Tighten the left and right lock nuts C to fix the position of the adjusting bolt B.

7. Test ride the motorcycle.

8. After the trial ride, please recheck whether the chain is adjusted correctly, and re-adjust if necessary.

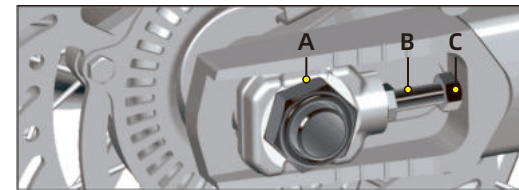

CAUTION

When adjusting the chain, adjust the adjusting bolts on both sides equally.

10.15

Maintaining Your Motorcycle

HEADLIGHT ADJUSTMENT

The angle of the headlights should be checked regularly. It must be re-adjusted after changing the angle of the whole motorcycle at any time because changes in the angle of the whole motorcycle will affect the angle of the headlights. Before adjusting the headlights, the shock absorption and tire pressure must be adjusted correctly. The illumination angle of the headlight can be adjusted vertically. If the illumination angle of the headlight is not suitable, it will cause the beam to point too close or too far.

Headlight angle adjustment:

1. When the headlight is in the low beam position, the motorcycle is perpendicular to the ground.

2. With the operator sitting on the motorcycle, verify the beam angle.
3. The adjusting screw A is located directly under the headlight.
4. To adjust the illumination angle of the headlight, please turn the screw until the correct beam angle is reached.
5. The correct illumination angle is 2.3-3.12 feet away from the ground from the near bright and dark cut-off line 32.8 feet away.

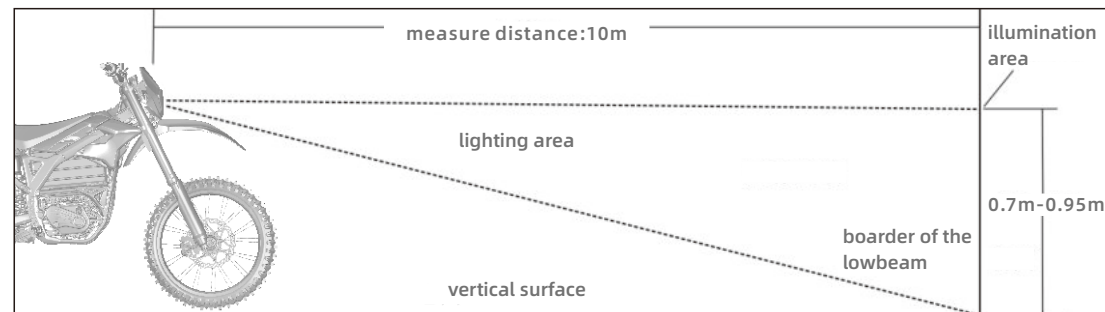
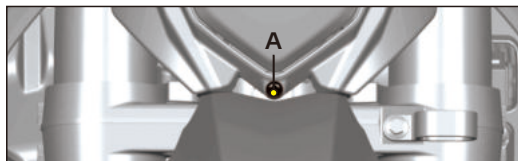

Maintaining Your Motorcycle

LIGHT/BULB REPLACEMENT

When the front light A is damaged, please contact an authorized dealer for a complete replacement.

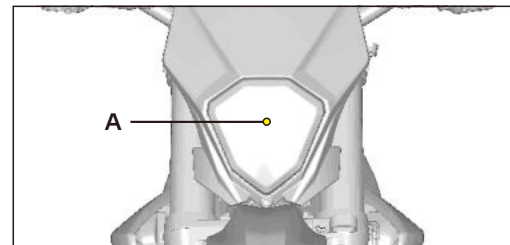

MOTORCYCLE CLEANING

1. Use a sponge or clean, soft cloth, neutral detergent and water to gently clean the motorcycle.
2. Be extra careful when cleaning the dashboard, it is easier to scratch than other parts of the motorcycle.
3. After cleaning, rinse the motorcycle thoroughly with water to remove all detergent residues.
4. Dry the motorcycle with a soft dry towel.
5. After cleaning, check for damage, wear or leakage.

After cleaning the motorcycle, please maintain the chain and other parts that need to be lubricated. Please let all electrical components dry before operation. If the Storm Bee electric motorcycle is to be ridden immediately after cleaning, use the brakes several times at a safe and low speed to remove the water on the brake pads.

Maintaining Your Motorcycle

CAUTION

Improper cleaning can damage motorcycle parts. Do not use high-pressure water guns to flush bearings, seals, electrical components, and plugs. In order to prolong the service life of the Storm Bee electric motorcycle, it should be cleaned and maintained regularly, and it is recommended to wipe it dry as soon as possible after cleaning.

Do not use any harsh chemical products on plastic parts. Avoid using strong corrosive cleaners, solvents or thinners, fuel (gasoline), rust removers or inhibitors, brake fluid, antifreeze in contact with Storm Bee electric motorcycle to avoid damaging certain parts.

WARNING

After cleaning and before starting to ride, be sure to test the brakes.

10.18

Wheel and tire cleaning

Avoid using strong acid wheel cleaners. If you use this type of product to clean stubborn dirt, please try to clean it in a short time and dry it immediately.

WARNING

Any tire maintenance products may reduce the friction between the tire and the ground, and even cause the tire to age prematurely.

LONG-TERM STORAGE

For motorcycles that have not been used for a long time (more than 30 days), it is recommended to charge to about 60% to 80% of the battery power and disconnect the cable between the Storm Bee electric motorcycle and the battery pack.

Completely clean all parts of your Storm Bee. If your Storm Bee has been exposed to sea air or salt water, wash it down with fresh water and wipe dry.

Change the engine oil and filter.

The battery pack also discharges slowly when stored. Check the power of the battery pack at least once every

Maintaining Your Motorcycle

long period of time may reduce the life of the battery pack or even damage the battery pack. Damage to the battery pack caused by over-discharge or long-term extremely low power is not covered by the warranty.

Removal from Storage

- 1、Uncover and clean your Storm Bee.
- 2、Change the reduction gearbox oil if more than 4 months have passed since the start of storage.
- 3、Charge the battery to full capacity.

If the coolant level lowers, add coolant and repeat the above procedure.

- 4、Perform all maintenance checks.

STORM BEE/ELECTRIC MOTORCYCLE// PARTS

Storm Bee electric motorcycles require the use of accessories specified by the manufacturer. Through your dealer, you can obtain original spare parts for maintenance of the Storm Bee electric motorcycle.

month. If the power drops below 30%, it should be recharged to 60% to 80%. When you are ready to use the Storm Bee electric motorcycle again, please fully charge the battery pack to ensure that the battery pack is restored to its best condition.

In order to prolong the service life of the power system, the Storm Bee electric motorcycle should be stored in a cool and ventilated place. Storing the Storm Bee electric motorcycle in a hot or humid place will shorten the life of the battery pack and electrical system. For more information about batteries and electrical systems, please refer to page 8.1.

WARNING

Only professionally trained technicians can provide maintenance services to the battery pack. Please note that unauthorized handling of the internal components of the battery pack may be dangerous. Do not disassemble!

CAUTION

Do not store the Storm Bee electric motorcycle with a battery power lower than 30%. Discharging the battery pack below 30% for a

10.19

Maintaining Your Motorcycle

FUSE

The motorcycle electrical system has a multi-channel overcurrent protection device. The fuse used is a one-time protection device, which will fuse and protect when the circuit is overloaded. When replacing the fuse, use the same specification model.

CAUTION

If the fuse blows repeatedly, please contact the dealer to check the electrical system.

10.20

Low voltage fuse box

The low voltage fuse box is located at the left rear of the steering column.

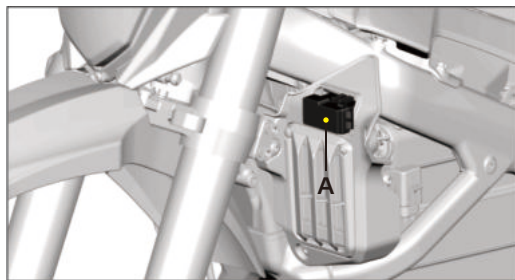

The fuse has a protective cover, which must be opened first to access the fuse. To open the cover, press down firmly on the tab, and then open the cover.

Replace a Low voltage current fuse:

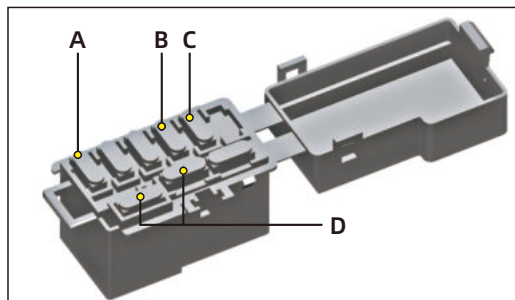

1. Pinch the fuse box cover and open the box cover to the right of the fuse box.
2. To replace the fuse, you need to replace the fuse of the same specification.

The functions corresponding to the 12-volt fuse are listed below:

High voltage fuse box

The high-voltage fuse box A is located in the left side

Maintaining Your Motorcycle

| | Amp | Purpose |
|---|--------|-------------------------|
| A | 10A | Motorcycle main fuse |
| B | 5A | Liquid-cool system fuse |
| C | 5A | USB fuse |
| D | 5A/10A | Backup fuse |

shield of the motorcycle body.

Replace the high-voltage fuse:

1. Disconnect the battery pack from the motorcycle circuit and take out the battery pack.

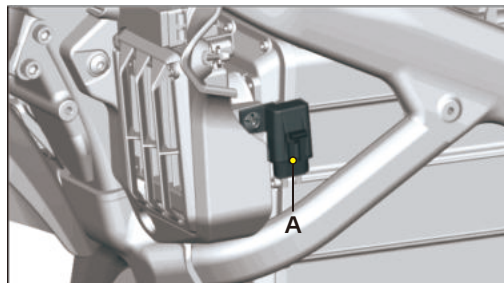

2. Open the bayonet and remove the fuse holder A.
3. Replace the fuse.

The model of the high-voltage fuse is 5A.

CAUTION

Please wear insulated gloves to replace and be careful to disassemble and assemble to avoid damage.

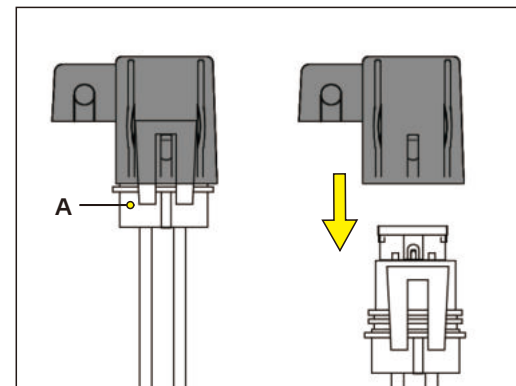

10.21

Maintaining Your Motorcycle

ELECTRICAL/CIRCUIT/DIAGRAM

10.22

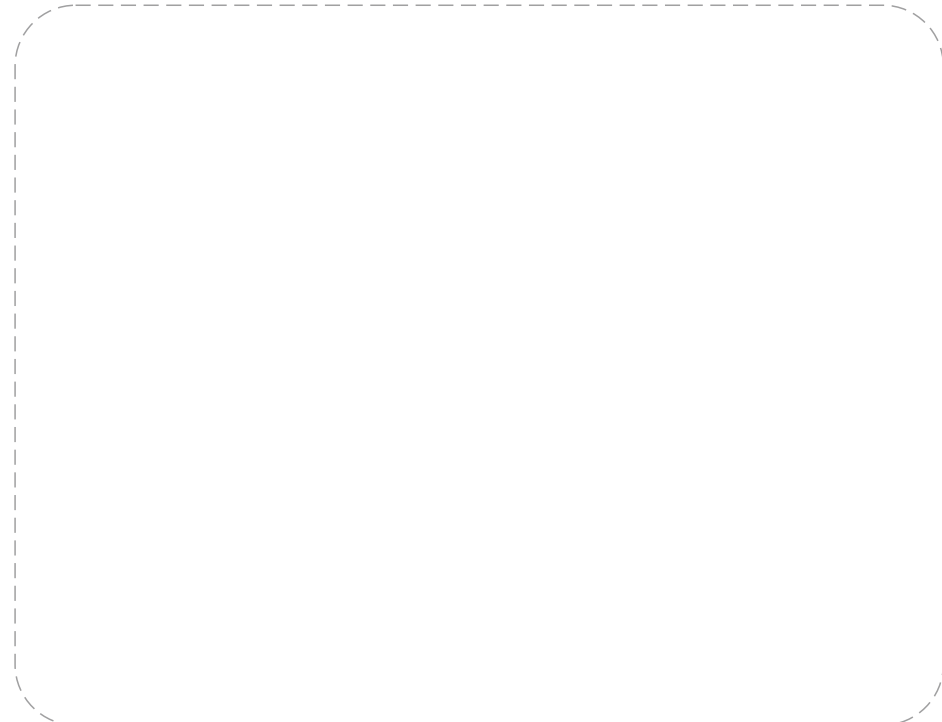
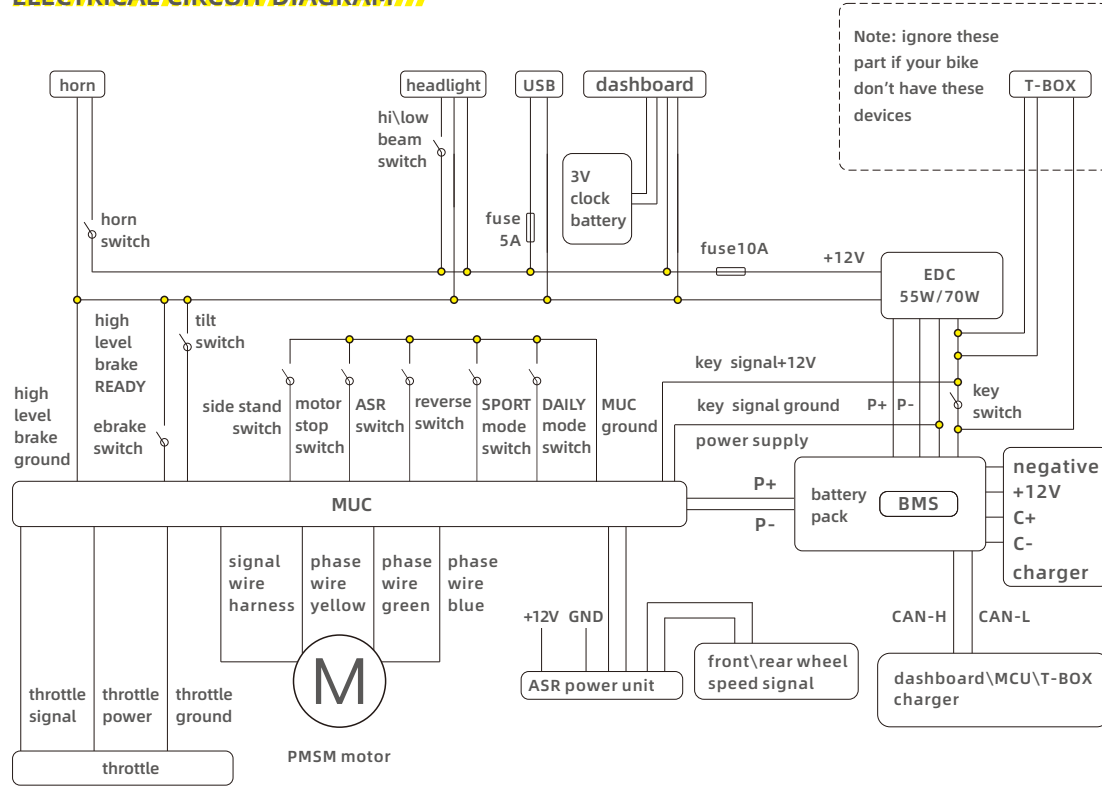

Troubleshooting

STORM/BEE/TROUBLESHOOTING////

All Storm Bee electric motorcycles are carefully inspected before delivery. Even if the Storm Bee electric motorcycle is inspected, some technical problems may occur.

The following information provides guidelines to help you identify problems and do the basic maintenance. If you are unable to solve the problem by yourself, please bring it to an authorized dealer at your convenience. If there is no dealer in your area, call the manufacturer customer service.

TEMPERATURE/PRECAUTIONS////

Cold Weather

The cold weather will not permanently affect battery capacity. However, riders may find their range and power reduced as cold temperatures have an impact on the amount of energy the battery pack can release.

Therefore, when used in an environment below 32°F compared to an environment at 77°F, the motorcycle may temporarily reduce its range by around 30%.

In extreme cold weather, the Storm Bee motorcycle may also temporarily reduce power and fail to reach top

speed.

It is not recommended to ride the motorcycle when the battery pack temperature is below 23°F. If used at low temperatures, the battery pack must be placed at temperatures above 32°F for charging. The battery management system does not allow the battery pack to discharge below -4°F, it's the standard specified by the battery manufacturer.

It is recommended to store the Storm Bee electric motorcycle in a suitable temperature environment.

It can be stored in the following conditions:

1. Temperature should not be lower than -4°F, better above 32°F.
2. Before storage, charge the battery pack to 60% ~ 80% of the power state. You should check its power state at least once a month. If the battery pack power drops below 30%, it should be recharged to 60% ~ 80%.
3. The battery pack can only charge at temperatures above 32°F. Storage temperatures below -4°F may permanently lower battery pack performance. Keep the temperature above -4°F and following long-term storage guidelines (please refer to "Long-term Storage" on page 10.18) will ensure that the battery pack in good condition during winter storage.

Hot Temperature

In high temperature, the battery won't have any performance changes. However, when the battery temperature is higher than 131°F (subject to the standard), the battery management system will turn off the output to avoid damage.

The charger will protect the battery pack by lowering the charging power when battery temperature above 131°F, which may increase the charging time. When the battery temperature exceeds 131°F, the battery management system will no longer allow charging.

CAUTION

In charging, to prevent battery pack been damaged, battery management system (BMS) will stop charging when ambient temperature is lower than 32°F. Please remember battery will not be serious damaged when ambient temperature is over -4°F and the battery capacity is also over 30%.

Troubleshooting

Please do not place the electric motorcycle or its battery in an environment higher than 105.8°F or in direct sunlight for an extended period of time, which may accelerate the degradation of battery performance.

SAFETY/INTERLOCK////

When battery pack is connected to the motorcycle, if the battery management system detects a serious internal failure, one or both of two measures will be taken to prevent damage to the battery pack:

Prohibited the use. If the battery pack charge is zero, or if the battery management system detects some serious internal problems, the motorcycle will be prohibited from use until the problem is resolved.

Charging is prohibited. If the battery management system detects some serious internal problems, it will prevent charging, even if the battery pack is connected to the charger and plugged into AC power until the problem is resolved.

STORM BEE PRECAUTIONS

Storm Bee electric motorcycle has a high voltage component. Take proper precautions when using it. The high voltage used in these components is dangerous and can result in burns, electric shocks and even serious personal injury.

For safety purposes always follow the instructions on

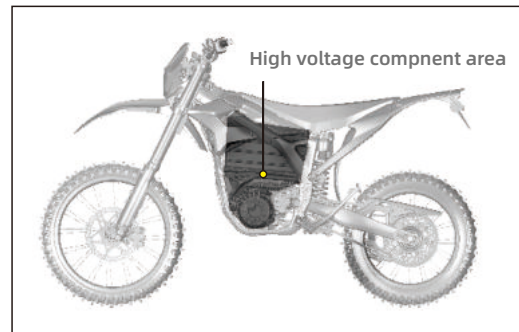

the label attached to the motorcycle parts and do not touch or attempt to remove or replace any high voltage parts, wiring (marked by the orange outer bushing) or connectors. In the event of an accident, do not touch any high voltage terminals or components connected to the wires. In case of a fire on the electric motorcycle, secure yourself first and then use Class D fire

extinguisher to put out the fire. When the flame is out, use plenty of water or a water-based fire extinguisher to cool it down.

WARNING

Storm Bee electric motorcycle uses a high voltage of 96V.

At the same time, the power system may be too hot to touch after work. Beware of high pressure and high temperatures and obey all the safety rules.

SERIOUS WARNING

The high voltage circuit system of the electric motorcycle is not allowed to be maintained by the user. Removing and replacing high-voltage components, cables, or connectors may result in severe burns or electric shocks, or even life-threatening injuries.

High-voltage cables are labeled orange for easy identification.

SYSTEM WARNING MESSAGE

When a fault is detected, the orange fault indicator A on the top of the instrument will light up, and the corresponding error code will be displayed in the B area on the LCD of the dashboard.

Note: When motorcycle had issue, the fault indicator will illuminate when in Total mileage mode; error code will show when in Trip mileage mode.

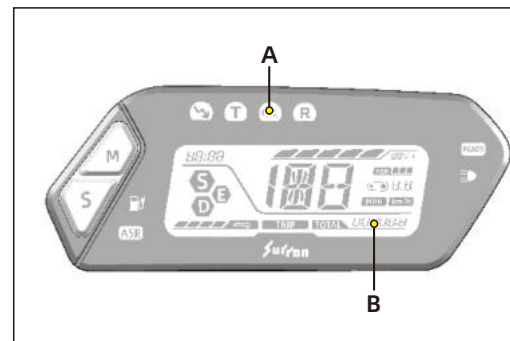

Please refer to the table starting on the next page for possible causes and solutions.

Troubleshooting

ERROR CODE CHART

| ERROR CODE | ERROR DESCRIPTION | SOLUTION |
|------------|---|--|
| ER-000 | Dashboard data communication protection | Check dashboard wire connection |
| ER-003 | Over discharge protection (level 2) | Bike enter Low Power Mode, check if motor is in locked rotor condition. |
| ER-004 | REGEN overcurrent protection (level 2) | Lower REGEN setting |
| ER-008 | Battery discharge MOS over temperature protection (level 2) | Stop using the bike and contact manufacturer or authorized dealer |
| ER-010 | Battery charge MOS over temperature protection (level 2) | |
| ER-011 | Startup self-test over temperature protection (level 1) | Turn OFF the key switch and back to ON again |
| ER-013 | Battery cell temperature unbalance protection (level 2) | Stop using the bike and contact manufacturer or authorized dealer |
| ER-015 | Battery pack insulation protection (level 2) | |
| ER-017 | Battery cell volume unbalance protection (level 2) | Contact manufacturer or authorized dealer |
| ER-019 | Battery cell under voltage protection (level 3) | Charging the battery pack |
| ER-022 | Over discharge protection (level 3) | Stop using the bike and contact manufacturer or authorized dealer |
| ER-024 | Battery cell discharge over temperature protection (level 3) | Stop using the bike and wait until the temperature back to working condition |
| ER-025 | Battery cell discharge under temperature protection (level 3) | |
| ER-030 | BMS protection board 1 error | Contact manufacturer or authorized dealer |
| ER-031 | BMS protection board 2 error | |

11.5

Troubleshooting

| | | |
|--------|---|--|
| ER-037 | Battery hall sensor error | Contact manufacturer or authorized dealer |
| ER-038 | Battery voltage sensor error | |
| ER-040 | Battery all temperature sensor error | |
| ER-041 | Startup self-test temperature sensor error | |
| ER-043 | Battery discharge MOS error | |
| ER-044 | Battery charge MOS error | |
| ER-100 | MCU electron tube error | Bike enter Low Power Mode |
| ER-101 | MCU over current protection (level 1) | |
| ER-104 | Motor position sensor error | Contact manufacturer or authorized dealer |
| ER-105 | Motor locked rotor error | Check if motor is in locked rotor condition |
| ER-106 | MCU sampling error | Contact manufacturer or authorized dealer |
| ER-107 | MCU over temperature protection (level 2) | Stop using the bike and wait until the MCU temperature back to working condition |
| ER-108 | Motor over temperature protection (level 2) | |
| ER-109 | Main power cable instant Low voltage protection | Check MCU main power cable |
| ER-110 | Main power cable Low voltage protection (level 3) | Charging the battery pack |
| ER-111 | Main power cable high voltage protection | Disable REGEN function |

11.6

Troubleshooting

11.7

| | | |
|--------|--|--|
| ER-113 | Battery cell over/under temperature protection (level 3) | Stop using the bike and wait until the temperature back to working condition |
| ER-114 | Throttle signal protection | Check if throttle cable is short circuited or unable back to idle position |
| ER-115 | Throttle ground protection | Check if throttle cable is short circuited, cable damaged or broken |
| AL-116 | E-brake triggered | Check if e-brake is short circuited |
| AL-117 | Side stand switch/motor stop switch triggered | Check if side stand switch is still down |
| AL-118 | Tilt switch protection | Check tilt switch |
| ER-119 | Main power cable Low power protection | Check bike communication cables, charge the battery pack |
| ER-127 | Motor temperature sensor error | Contact manufacturer or authorized dealer |
| AL-128 | REGEN turned OFF | Check battery temperature and battery voltage |
| ER-129 | CAN communication error | Check all wire and cables |
| ER-130 | Speed sensor error | Check if front and rear wheel speed sensor is well connected |
| ER-131 | Main power cable instant High voltage protection | Disable REGEN function |
| ER-133 | Key switch power loose protection | Check key switch and MCU cable connection |
| ER-134 | MCU firmware malfunction protection | Turn OFF the key switch and back to ON again |
| ER-135 | Battery single cell high voltage difference protection | Contact manufacturer or authorized dealer |
| ER-136 | High MOS discharging temperature MCU protection | Stop using the bike and wait until the temperature back to working condition |

Troubleshooting

11.8

| | | |
|--------|--|--|
| ER-137 | Battery single cell low voltage protection | Charging the battery pack and contact manufacturer or authorized dealer |
| ER-138 | MCU Regeneration Protection | Turn OFF the key switch and back to ON again |
| ER-144 | BMS discharging over current power limitation | Power limitation level 1 |
| ER-145 | Battery single cell high voltage difference power limitation | Power limitation level 2 |
| ER-146 | High MOS discharging temperature power limitation | Stop using the bike and wait until the temperature back to working condition |
| AL-147 | Battery single cell low voltage power limitation | Charging the battery pack and contact manufacturer or authorized dealer |

TROUBLESHOOTING

| Symptom | Potential cause | Potential solution |
|--------------------------------|--|--|
| Bike does not turn on | Battery not plug into correct position | Check battery plug |
| | SOC too low | Charging the battery |
| | Battery enters temperature protection | Wait temperature back to working condition |
| | Fuse melted | Check all wire and cables and replace fuse |
| | Key switch not properly engaged | Recheck key switch or replace new key switch |
| | DC converter error | Replace DC converter |
| Bike powered on but not moving | Battery malfunction | Contact manufacturer or authorized dealer |
| | Side stand switch protection | Side stand up |

Troubleshooting

Troubleshooting

| | | |
|--------------------------------|---|--|
| Bike powered on but not moving | E-brake protection | Check e-brake |
| | Tilt sensor was triggered but not reset | Switch off the key switch and turn on again after lift up the motorcycle |
| | Throttle not in idle position when start up | Check throttle position |
| | Battery low SOC protection | Charging the battery |
| | Motor temperature protection | Wait until the temperature back to working condition |
| | MCU temperature protection | |
| | Side stand switch error | Disconnect or replace side stand switch |
| | E-brake error | Disconnect or replace e-brake |
| | Tilt sensor error | Disconnect or replace tilt sensor |
| | Throttle error | Replace throttle |
| | MCU not plug in position | Check MCU plug |
| | Motor encoder not plug in position | Check motor encoder plug |
| | MCU or motor encoder error | Replace MCU |
| Replace motor | | |

11.9

| | | |
|---|--|---|
| Bike start ok but battery SOC not display | Coulombmeter not connect properly | Contact manufacturer or authorized dealer to repair battery |
| | Coulombmeter error | |
| Charger not working | Battery enters temperature protection | Wait until the temperature back to working condition |
| | A/C power missing; charger not plug properly | Check power source and plug again |
| | Charger malfunction | Replace charger |
| | Battery malfunction | Contact manufacturer or authorized dealer |
| Riding mode malfunction and power reduced | Low battery | Charge battery |
| | Battery temperature protection | Wait until the temperature back to working condition |
| | MCU or motor temperature protection | |
| | Riding mode switch error | Replace riding mode switch |
| USB port no power | USB not plug properly | Check USB connection and plug again |
| | USB converter error | Replace USB converter |

11.10

Note: We will keep updating all the informations above, please check latest version on our website.

Warranty and After-sales Information

HOW TO OBTAIN WARRANTY SERVICE

To receive any type of warranty service, take your Surron motorcycle and warranty registration proof to any authorized Surron dealer during normal service hours. If you believe that your vehicle has a defect which could cause a crash or could cause injury or death, you should immediately inform Surron or your Surron authorized dealer. If you fail or does not meet the conditions and scope of the warranty terms, we can still provide repair services upon your request with certain charge.

12.1

NOTE

We will complete the warranty work as soon as possible, but not responsible for delays in work caused by factors beyond our control. The aforementioned factors include but are not limited to: shortage of spare parts, delay in transportation, force majeure, etc.

REPORTING SAFETY DEFECTS

United States

If you believe that your vehicle has a defect which could cause a crash or could cause injury or death, you should immediately inform the National Highway Traffic Safety Administration (NHTSA) in addition to notifying Surron. If NHTSA receives similar complaints, it may open an investigation, and if it finds that a safety defect exists in a group of vehicles, it may order a recall and remedy campaign. However, NHTSA cannot become involved in individual problems between you, your dealer, or Surron. To contact NHTSA, you may call the Vehicle Safety Hotline toll-free at:

1-888-327-4236 (TTY: 1-800-424-9153); go to

<http://www.safercar.gov>; or write to:

Administrator

National Highway Traffic Safety

1200 New Jersey Avenue SE

Washington, DC 20590

You can also obtain other information about motor vehicle safety from: <http://www.safercar.gov>

Warranty and After-sales Information

Canada

If you believe that your vehicle has a defect which could cause a crash or could cause injury or death, you should immediately inform Transport Canada, in addition to notifying Surron.

To contact Transport Canada, call their toll-free number:

+1-800-333-0510

United Kingdom, Europe, and Global Markets

If you believe that your vehicle has a defect which could cause a crash or could cause injury or death, you should immediately inform your Surron authorized dealer. If you are unable to resolve the issue with your Surron authorized dealer you can contact Surron directly on +86-23-6890-5603, or through our website at:

<http://www.sur-ron.com>

12.2

| PARAMETERS LIST——VEHICLE MODEL: QL1000DY | |
|--|---|
| | STORM BEE E NA |
| Dimension | 81.9 x 31.7 x 48.8 in |
| Ground clearance | 12.2 in |
| Seat height | 37 in |
| Dry/Curb weight | 95kg/127kg |
| Carrying capacity | 100kg |
| Front tire | 80 / 100-21 off road tire |
| Rear tire | 100 / 90-18 off road tire |
| Assistance functions | ASR + BERS (optional) |
| Wheel base | 56.3 in |
| Front fork travel | 11.4 in |
| Rear shock/wheel travel | 115/11.4 in |
| Power system | Mid-drive BLDC motor + FOC sine wave controller |
| Rated power | 10KW |
| Maximum power | 22.5KW |
| Maximum torque | 383.5 ft-lbs |
| Top speed | 68mph |
| Range@ 31mph | 75 miles |
| Battery Type | 104V/55Ah lithium-ion removable battery pack |
| Charge time | 4h |
| Frame design | Aluminum forged frame |
| Riding mode | Eco / Daily(Rain) / Sport mode + "Turbo " mode |

Changes or modifications not expressly approved by the party responsible for compliance could void the user's authority to operate the equipment.

NOTE

Changes or modifications not expressly approved by the party responsible for compliance could void the user's authority to operate the equipment.

NOTE: This equipment has been tested and found to comply with the limits for a Class A digital device, pursuant to part 15 of the FCC Rules. These limits are designed to provide reasonable protection against harmful interference when the equipment is operated in a commercial environment.

This equipment generates, uses, and can radiate radio frequency energy and, if not installed and used in accordance with the instruction manual, may cause harmful interference to radio communications.

Operation of this equipment in a residential

area is likely to cause harmful interference in which case the user will be required to correct the interference at his own expense.

You and the Environment

Owning and riding a motorcycle can be enjoyable, but you must do your part to protect nature. When you show respect for the land, wildlife, and other people, you also help preserve the sport of off-road riding.

Following are tips on how you can be an environmentally responsible motorcycle owner.

1.Choose sensible cleaners. Use a biodegradable detergent when you wash your Storm Bee. Avoid aerosol spray cleaners that contain chlorofluorocarbons which damage the atmosphere's protective ozone layer. Don't throw cleaning solvents away; see the following guidelines for proper disposal.

2.Recycle Wastes. It's illegal and thoughtless to put used engine oil in the trash, down a drain, or on the ground. Use coolant, and cleaning solvents contain

poisons that can hurt refuse workers and contaminate our drinking water lakes, rivers, and oceans.

3. Put toxic wastes in separate sealed containers and take them to.