

Indian Railways YDM4 Kit

H0m Scale (1:87, meter gauge)

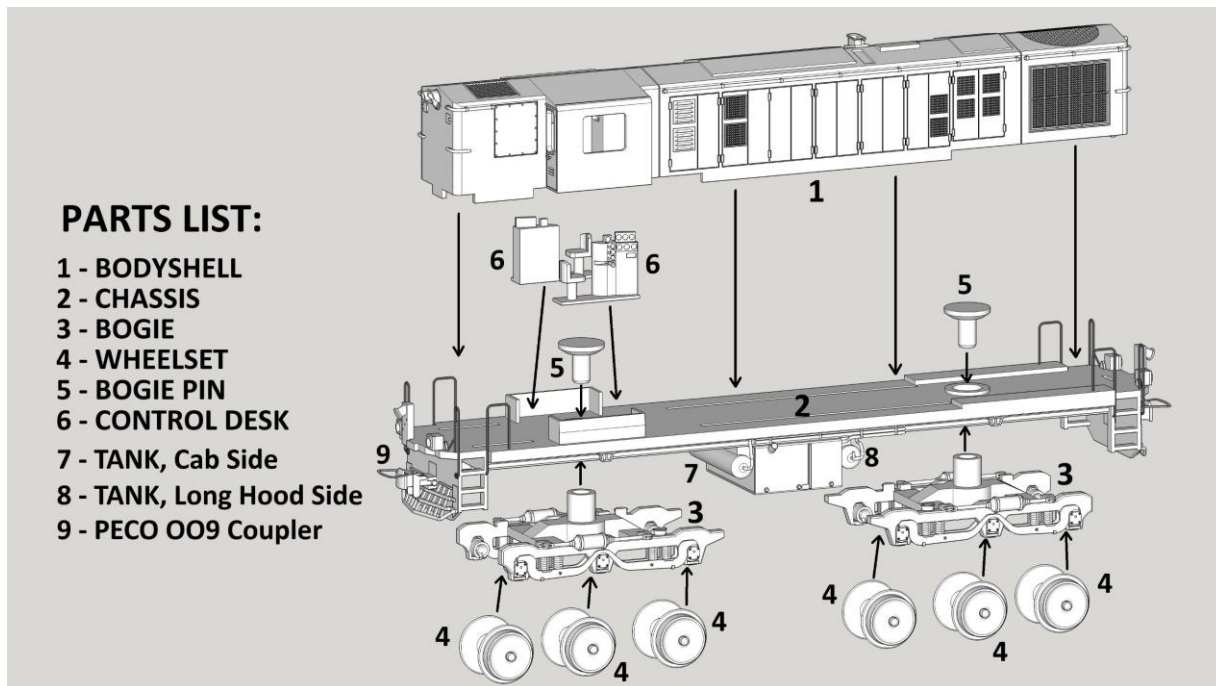

Congratulations! You now own a unique Indian Railway model kit by Precision Model Works. We are so very happy that you chose to model something one of a kind and gave us the opportunity to help you make your dream model. Before you get started here are a few things that you should know.

Our models are 3D printed, in particular, resin 3D printed. As much as it looks just like any other plastic model kits, there are few nuances that you need to be aware of:

- Resin shrinks and expands during the printing and curing process. So, no matter how precise our designs are, mating parts might have slight differences in dimensions and tolerances. **You are expected to use a file and sand paper to prep your model wherever necessary.** We recommend a needle file set for rough adjustments and a 1000 grit sand paper for finishing.
- We use latest 3D printing technology to print in very high definition, but since 3D printing works in layers, it is impossible to avoid print lines and support marks in certain areas. While the support marks in our models are always in obscure places, **you might have to do very light sanding in some visible parts depending on your appetite of fit and finish.** We recommend at least 1000 grit sand paper, but 1500 grit will be better.
- Resin printed parts sands easier/faster than ABS. While it makes making models much easier, there is a risk that you might end up sanding too much. So, be gentle with your sanding and check the fit frequently.
- There is no alternate of a good primer! **We strongly recommend that you use a good primer, preferably airbrushed or spray painted on the model before you start painting.** A 24-hour minimum curing time should be given before painting.
- You are expected to paint all parts separately and then assemble them. In some cases, you can assemble/glue some parts that are integral in nature and then paint the whole assembly together.
- **Superglue / CA glue works the best to fix components.** We recommend using the gel type ones which will give you a little more time to set things before the glue cures. Use an accelerator for situations that need faster curing. Moderation is key.

Key Instructions:

- Familiarize yourself with the parts using the exploded diagram above.
- Check for fitment of all major parts before starting your assembly and gluing any parts. File /sand as necessary.
- The wheels are a two-part design, you need to push the pointed /conical part of the axle through the central hole of the separate wheel. You need to file the hole as necessary using a micro-file. You also need to file the part of the axle to remove any support burrs left on the print – make sure to move the axle in circular motion not to get a flat surface on it while filing.
- If you are making a model that will run on a layout, it is important to keep the wheel perfectly square with the axle for best performance on tracks. You might want to do some tests on a slightly inclined piece of track to ensure that the wheel rolls properly.
- Once you are satisfied that the wheels are properly installed with the axle, use standard super glue /CA glue (not the gel type) to fix the wheels in place. Apply glue from the back of the wheel. **We highly recommend replacing the 3D printed wheels with metal model train wheels if you wish to run these on a layout frequently.**
- The bogie installation is a simple two-part design. You need to put the tube on the bogie through the hole in the chassis first. Put a dab of superglue on the end of the bogie pin (part 5) and push through the hole in the pivot tube on the bogie. Make sure to paint and weather the chassis and the bogies before this step.
- In the image above you will find that we recommend using Peco OO9 coupling. This is of course for those who wish to run the coaches on a layout. However, we have provided 3D printed couplers in the package – one pair is accurate representation of the real couplers, other is just like the real coupler, but with the broad coupling pin removed. You will find a hole in these alternate couplers. If you wish to make a coupled rake, you can push a U-shaped pin through the holes of two adjoining couplers – it is an inexpensive and prototypically accurate closed coupling solution.

- The handrail diagram provides the placement of the handrails. You will find 3D printed versions of these handrails in the box that contains the details parts of the model.
- Because of the very nature of how resin 3D printing works, the handrails are fragile. So, if you wish to handle your model frequently, then we recommend that you replace them using wire handrails.

