

Indian Railways NDM5/ZDM5: OO9/HOe Motorization version

PLEASE READ BEFORE YOU BUILD

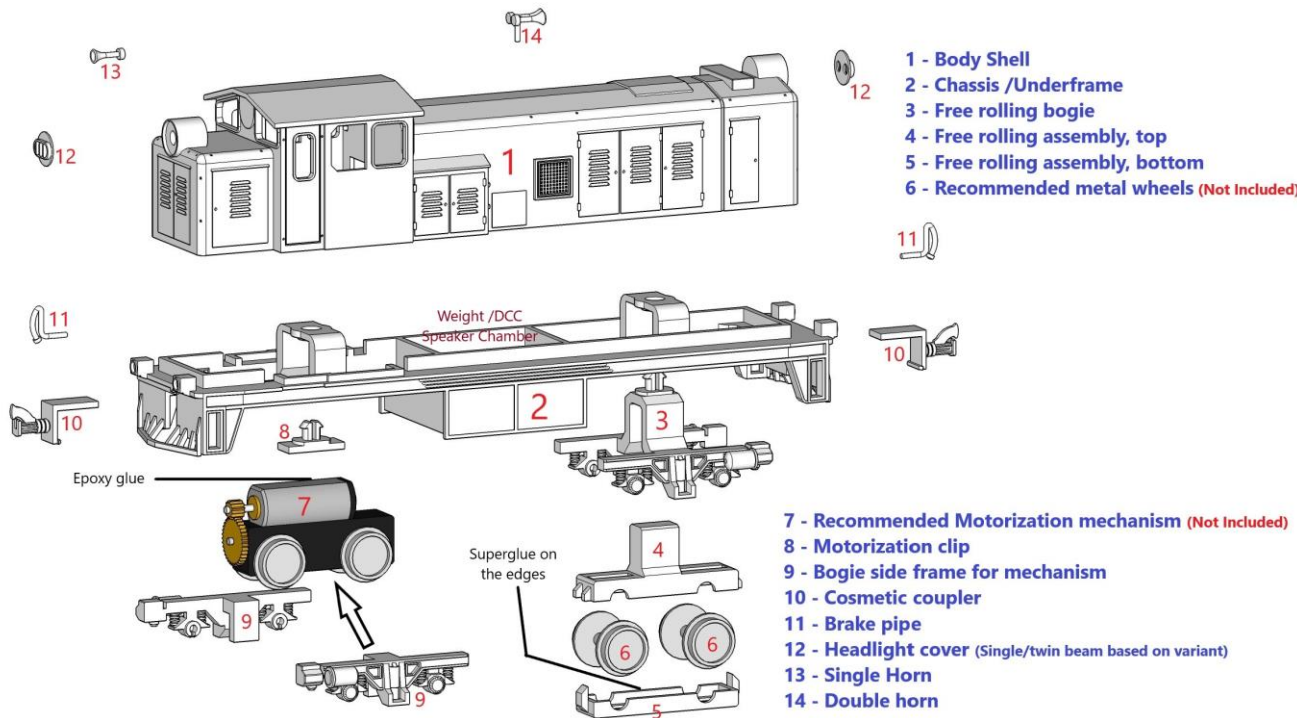

Congratulations! You now own a unique Indian Railway model kit by Precision Model Works. We are so very happy that you chose to model something one of a kind and gave us the opportunity to help you make your dream model. Before you get started here are a few things that you should know.

Our models are 3D printed, in particular, resin 3D printed. As much as it looks just like any other plastic model kits, there are few nuances that you need to be aware of:

- Resin shrinks and expands during the printing and curing process. So, no matter how precise our designs are, mating parts might have slight differences in dimensions and tolerances. **You are expected to use a file and sand paper to prep your model wherever necessary.** We recommend a needle file set for rough adjustments and a 1000 grit sand paper for finishing.
- We use latest 3D printing technology to print in very high definition, but since 3D printing works in layers, it is impossible to avoid print lines and support marks in certain areas. While the support marks in our models are always in obscure places, **you might have to do very light sanding in some visible parts depending on your appetite of fit and finish.** We recommend at least 1000 grit sand paper, but 1500 grit will be better.
- Resin printed parts sands easier/faster than ABS. While it makes making models much easier, there is a risk that you might end up sanding too much. So, be gentle with your sanding and check the fit frequently.
- There is no alternate of a good primer! **We strongly recommend that you use a good primer, preferably airbrushed or spray painted on the model before you start painting.** A 24-hour minimum curing time should be given before painting.
- **Superglue / CA glue works the best to fix components.** We recommend using the gel type ones which will give you a little more time to set things before the glue cures. Use an accelerator for situations that need faster curing. Moderation is key.

Key Instructions:

- Familiarize yourself with the parts using the exploded diagram above.
- Check for fitment of all major parts before starting your assembly and gluing any parts. File /sand as necessary.
- For all handrail holes, make sure to drill the holes PRIOR to priming your model. These marks are very tiny and you might lose them if you don't drill the holes before applying the primer/paint.

Motorization:

We recommend using **Narrow Japan /Narrow Garage NG-NP1607 (for OO9) OR NG-NP1407 (for HOe)** to motorize your **PMW OO9/HOe NDM5 kit (NOT INCLUDED IN OUR KIT)**. This is a 'drop-in' mechanism that fits the dimension perfectly and we have also included a mounting clip that you have to glue on the mechanism using a 2-part epoxy glue (fig 1 – *3D printed mechanism used for demonstration purposes only, not provided in the kit*). You also need to glue the two bogie frames to the mechanism between the two wheels (fig 2) and then push the complete assembly through the mounting hole on the chassis (fig 3). Note that you need to paint all necessary parts before you glue them and finish assembly.

The other bogie is to be free rolling. Since we are recommending the use of the Narrow Garage mechanism, you might find it easier to use their wheel assembly **NG-P103** since the dimensions will match perfectly with the mechanism as the same wheels are used in the mechanism too (fig 4). However, you can use any free rolling wheel assembly as long as the wheel diameter is 7mm. You need to place the wheels on the half bearing hole of one of the free rolling assemblies (fig 5), and press the other half in position carefully (fig 6). It's a press fit where the two engaging clips will hold the assembly together (fig 7), but be careful not to exert unnecessary pressure which might break the parts. You might also want to use a dab of super glue to secure the joint once assembled, and use plastic compatible lubricant on the bearing for free rolling of the wheels.

Indian Railways NDM5/ZDM5: OO9/HOe Motorization version

PLEASE READ BEFORE YOU BUILD



Fig 1



Fig 2

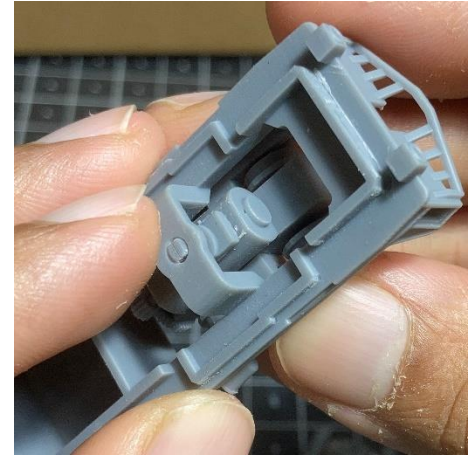

Fig 3



Fig 4



Fig 5



Fig 6

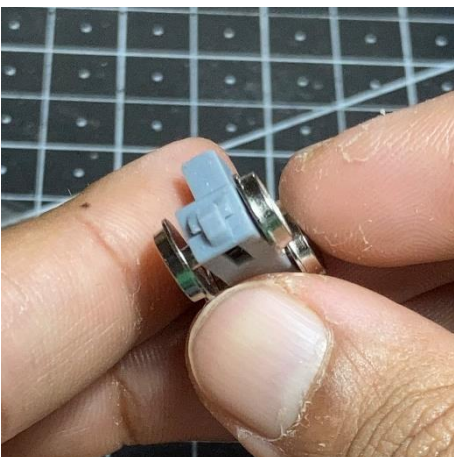

Fig 7

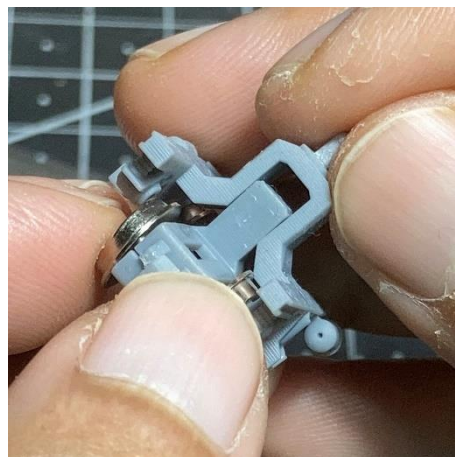

Fig 8



Fig 9



Fig 10

Once your free rolling assembly is complete you need to slide it in the square hold of the free rolling bogie frame (fig 8) and glue it in place using superglue (fig 9). Note, that you would want to complete painting your free rolling bogie frame before completing this step. Finally, at the right time of the assembly, you need to push the clip through the mounting hole to secure the free rolling bogie (fig 10).

If you wish, you can opt for two of mechanisms to make 2 motorized bogies to power your locomotives. We have provided two clips in the kit to do so and you can simply cut the bogie frames from the free rolling assembly and glue it to the other mechanism. However, if you need additional bogies frames to glue to the mechanism, you can email us at modelsprecision@gmail.com with your request.

It is recommended to use plastic compatible grease /lubricant in all mating joints with moving parts.

Indian Railways NDM5/ZDM5: OO9/HOe Motorization version



PLEASE READ BEFORE YOU BUILD

Adding headlights:

If you wish to add lights to your model, you need to complete the following steps **BEFORE** painting the models. Once the lights are installed, put **long term masking on the LEDs** to ensure the LEDs don't get exposed to paint. You need **2 pre-wired SMD LEDs** (available in eBay and many other places) – **0402** (preferred) or 0603 (Max size).

You need to drill a hole in the headlight housing where you see the bulb position is marked. Make sure to drill straight and NOT drill all the way through to the back of the headlight housing (fig 11).

Drill another hole from underneath the headlight housing, aligning the hole you drilled in the housing, again taking care that you don't drill through and through, but just catch the other hole that you drilled earlier (fig 12). You should get an 'L' shaped channel inside the headlight housing (fig 13 – shown in red dotted line). You can now draw the LED leads through this whole and attached to a suitable lighting circuit or DCC decoder. At the front, the LED should sit flush inside the hole provided for the bulb (fig 14).

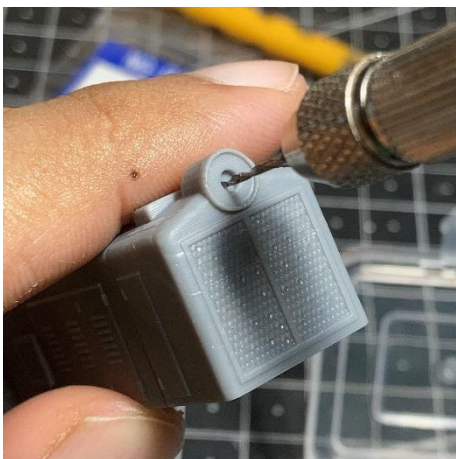

Fig 11

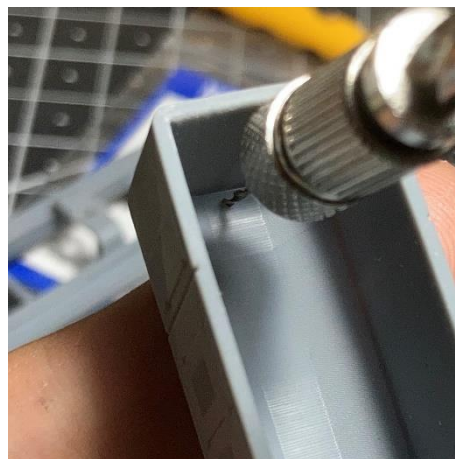

Fig 12

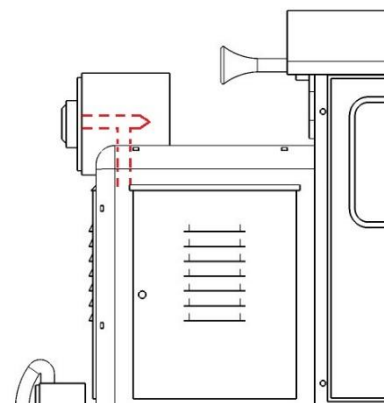

Fig 13

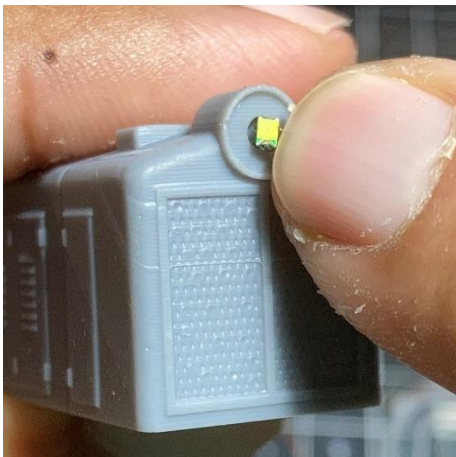

Fig 14

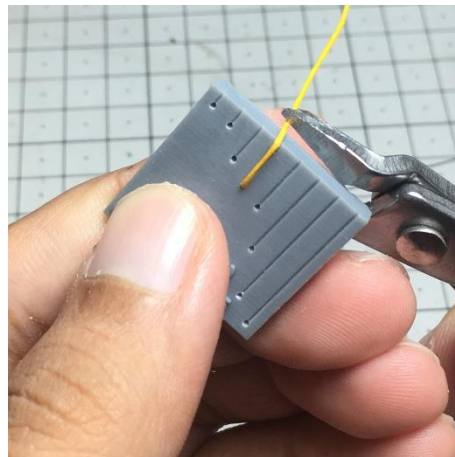

Fig 15

Handrails:

- You **MUST** drill all the holes for the handrails before you apply primer. The holes on the models are very small so you might lose them after first coat of paint. You need a 0.3 – 0.5 mm micro drill and a pin vice for the best results.
- Refer to Handrail identification diagram to familiarize yourself with the handrail positions and numbers. You might need this to find the little holes on the model as well.
- We have supplied a handrail making jig in the kit (Fig 15). These are the steps to use it:
 - Find the corresponding number of the handrail from the handrail identification diagram (fig 16).
 - Insert a 0.3 – 0.5mm wire in the hole in the jig.
 - Bend 90 degrees along the engraved line, press hard to make sure it's perfectly straight
 - Bend 90 degrees again at the edge, and cut at the bottom edge.
 - Trim the ends before fixing them to the corresponding section matching the handrail guide.
 - Use tiny drop of superglue on the tip and insert the ends to the holes on the models that you drilled earlier.

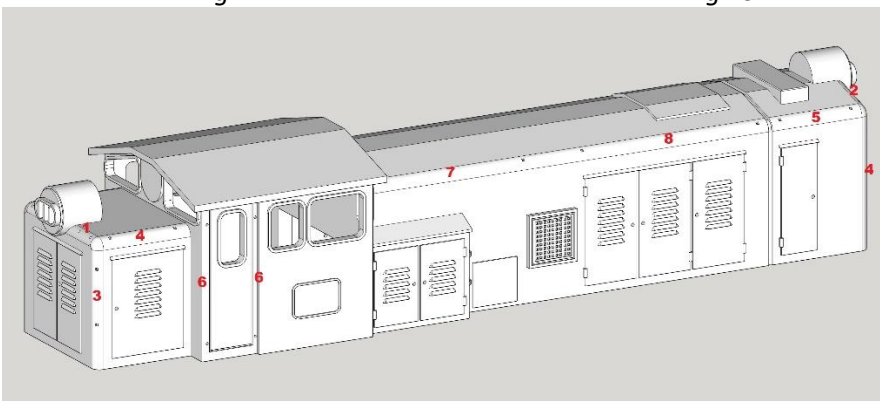

Fig 16

Indian Railways NDM5/ZDM5: OO9/HOe Motorization version



PLEASE READ BEFORE YOU BUILD

Coupling:

If you wish to run your locomotive regularly on a layout, then we strongly recommend using the Peco HOe/OO9 couplers for your locomotives and rolling stock. Peco GR-103 OO-9 Coupler Pockets will fit our chassis for all Narrow-Gauge rolling stock (you might have to file away small areas to make it fit) and you can then use any compatible Peco NEM coupler like GR-103 OO-9 Couplers.

We have however, provided two types of couplers in the packet. One is a display coupler that looks like the couplers used in the real locomotives and rolling stock. The coupler is shown in open position, so it is perfect to show the coupler at the end of the train or in a display model (Fig 17)

The other type of coupler provided in the package are DIY close-coupling solution which will let you run your trains, or show them in a coupled display position (Fig 18). In this, the 'hook' in the real coupling is omitted. Instead, you will find a tiny hole. In order to join the rolling stock, all you need is a U-shaped pin by bending any commonly available piece of wire that is not more than 0.3mm thick. Once you put this U-shaped pin through the holes of two installed couplers of adjoining rolling stock, you will get a pretty good coupling (fig 19) for display or even running, except, you need to open the pin manually if you need to uncouple.



Fig 17



Fig 18

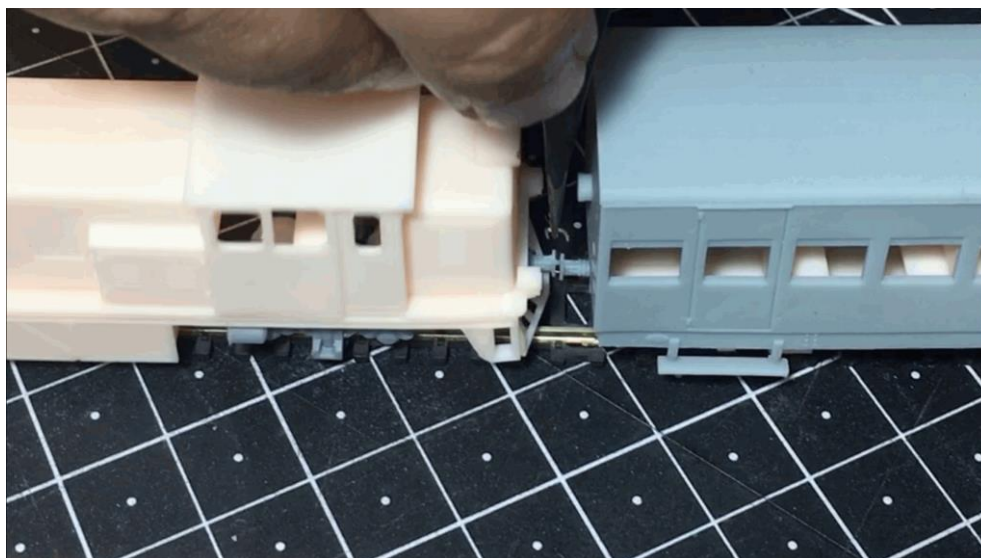

Fig 19