

Indian Railways Narrow Gauge C Van

Darjeeling Himalayan Railway in OO9

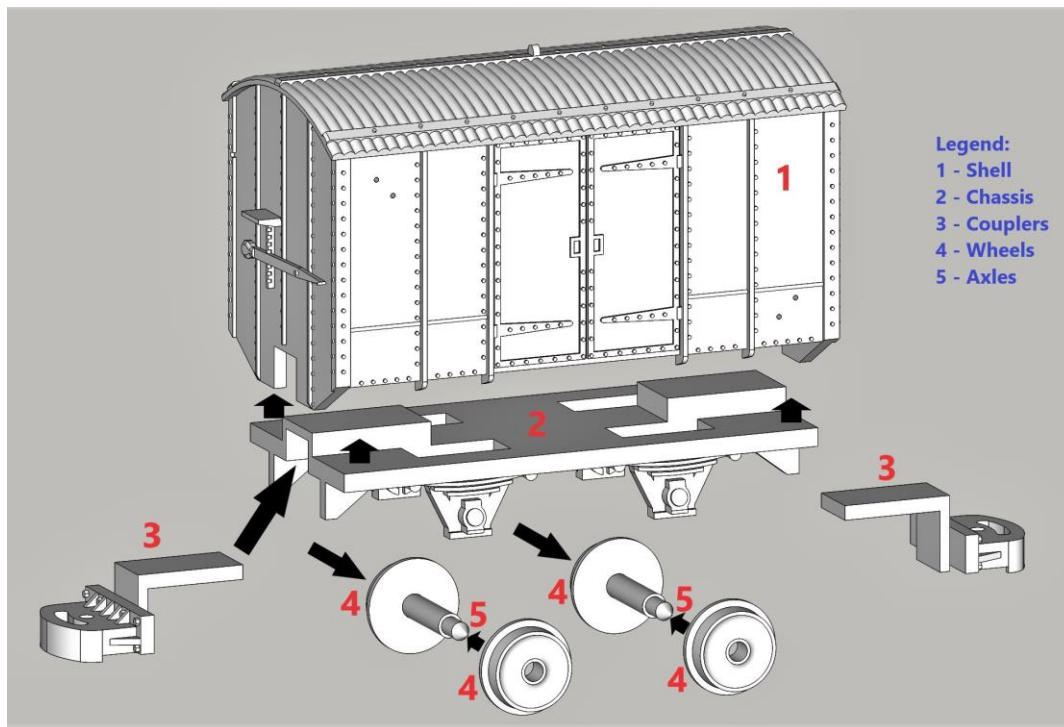

Congratulations! You now own a unique Indian Railway model kit by Precision Model Works. We are so very happy that you chose to model something one of a kind and gave us the opportunity to help you make your dream model. Before you get started here are a few things that you should know.

Our models are 3D printed, in particular, resin 3D printed. As much as it looks just like any other plastic model kits, there are few nuances that you need to be aware of:

- Resin shrinks and expands during the printing and curing process. So, no matter how precise our designs are, mating parts might have slight differences in dimensions and tolerances. **You are expected to use a file and sand paper to prep your model wherever necessary.** We recommend a needle file set for rough adjustments and a 1000 grit sand paper for finishing.
- We use latest 3D printing technology to print in very high definition, but since 3D printing works in layers, it is impossible to avoid print lines and support marks in certain areas. While the support marks in our models are always in obscure places, **you might have to do very light sanding in some visible parts depending on your appetite of fit and finish.** We recommend at least 1000 grit sand paper, but 1500 grit will be better.
- Resin printed parts sands easier/faster than ABS. While it makes making models much easier, there is a risk that you might end up sanding too much. So, be gentle with your sanding and check the fit frequently.
- There is no alternate of a good primer! **We strongly recommend that you use a good primer, preferably airbrushed or spray painted on the model before you start painting.** A 24-hour minimum curing time should be given before painting.
- **Superglue / CA glue works the best to fix components.** We recommend using the gel type ones which will give you a little more time to set things before the glue cures. Use an accelerator for situations that need faster curing. Moderation is key.

Key Instructions:

- Familiarize yourself with the parts using the exploded diagram above.
- Check for fitment of all major parts before starting your assembly and gluing any parts. File /sand as necessary.
- The wheels are a three-part design, you need to push the pointed /conical part of the axle through the central hole of the wheels. You need to file the hole as necessary using a micro-file (fig 1). You also need to file the part of the axle to remove any support burrs left on the print (fig 2) – make sure to move the axle in circular motion not to get a flat surface on it while filing.
- If you are making a model that will run on a layout, it is important to keep the wheel perfectly square with the axle for best performance on tracks. You might want to do some tests on a slightly inclined piece of track to ensure that the wheel rolls properly (fig3).
- Once you are satisfied that the wheels are properly installed with the axle, use standard super glue /CA glue (not the gel type) to fix the wheels in place. Apply glue from the back of the wheel (fig 4).
- Before you install the wheels, you need to put plastic friendly grease in the bearings (fig 5). This ensures smooth running of the rolling stock.
- To install the wheels, hold the wheel close to the bearing. Spread the suspension and journal assembly slightly to put one conical end, then spread the other end and repeat. Refer to fig 6. Tend not to put too much pressure as it might bend or break the fragile parts.
- If you wish to use the prototypical couplers provided in the kit to run your trains, then you need two U pins that look like stapler pins with their arms 6mm apart from each other (fig 7).
- You put one arm in the round hole of one coupler and the other arm in the curved cutout of the other coupler. You use the other pin to do the same for the other set of holes – cutout pair (fig 8).



Figure 1

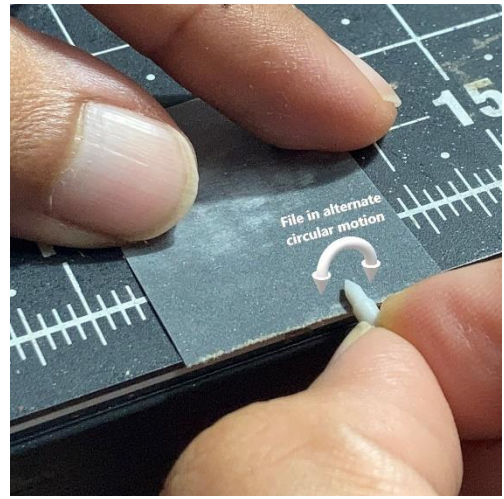

Figure 2



Figure 3



Figure 4



Figure 5



Figure 6



Figure 7

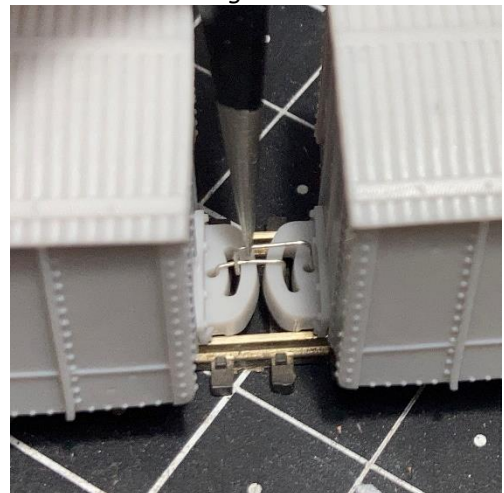

Figure 8

