



FASTLANE[®] PRO
By Endless Pools[®]

OWNER'S MANUAL





IMPORTANT SAFETY INSTRUCTIONS CONSIGNES DE SÉCURITÉ IMPORTANTES

READ AND FOLLOW ALL INSTRUCTIONS
LISEZ ET SUIVEZ TOUTES LES INSTRUCTIONS

Manufacturers Safety Instructions

- DANGER:** BEFORE INSTALLING OR USING THIS PRODUCT, READ AND FOLLOW ALL SAFETY INFORMATION. FAILURE TO DO SO CAN RESULT IN DAMAGE, INJURY, OR DEATH.
- DANGER:** SERIOUS BODILY INJURY OR DEATH CAN RESULT IF THIS PRODUCT IS NOT INSTALLED OR USED CORRECTLY.
- WARNING:** This unit should be installed only per the manufacturer's instructions.
- WARNING:** This product must be installed in accordance with any applicable state and local code. Consult the local building and health code for more information.
- WARNING:** Before each use, examine the unit for damage or signs of wear. Do not use the product if found in this condition. Contact Endless Pools Customer Service.
- WARNING:** NEVER operate the unit without reading and completely understanding the results of any operational change you request from the controller.
- WARNING:** Never use this product alone.
- WARNING:** Keep all breakables, especially glass, away from this product.
- WARNING:** Never insert any objects into any openings.
- WARNING:** Wear appropriate hearing and eye protection while drilling holes into any cementitious material.
- WARNING:** Consult a physician before using this product. Stop exercising if you feel pain or tightness in your chest, become short of breath, or feel faint. Contact your doctor before using this product again.

Other Important Safety Instructions

WARNING: To reduce the risk of injury, do not permit children to use this product unless they are closely supervised at all times.

AVERTISSEMENT: Pour réduire le risque de blessure, ne permettez pas aux enfants d'utiliser ce produit à moins qu'ils ne soient surveillés de près en tout temps.

WARNING: To reduce the risk of injury. **AVERTISSEMENT:** Pour réduire le risque de blessure:

- a) The water in a spa should never exceed 104 °F (40 °C). Water temperatures between 100 °F (38 °C) and 104 °F (40 °C) are considered safe for a healthy adult. Lower water temperatures are recommended for young children and when spa use exceeds 10 minutes. L'eau dans un spa ne doit jamais dépasser 40 °C (104 °F). Les températures de l'eau comprises entre 38 °C (100 °F) et 40 °C (104 °F) sont considérées comme sûres pour un adulte en bonne santé. Des températures d'eau plus basses sont recommandées pour les jeunes enfants et lorsque l'utilisation du spa dépasse 10 minutes.
- b) Since excessive water temperatures have a high potential for causing fetal damage during the early months of pregnancy, pregnant or possibly pregnant women should limit spa water temperatures to 100 °F (38 °C). Étant donné que les températures excessives de l'eau ont un potentiel élevé de causer des dommages au fœtus pendant les premiers mois de la grossesse, les femmes enceintes ou éventuellement enceintes devraient limiter la température de l'eau du spa à 38 °C (100 °F).
- c) Before entering a spa, the user should measure the water temperature since the tolerance of water temperature-regulating devices varies. Avant d'entrer dans un spa, l'utilisateur doit mesurer la température de l'eau car la tolérance des dispositifs de régulation de la température de l'eau varie.
- d) The use of alcohol, drugs, or medication before or during spa use may lead to unconsciousness with the possibility of drowning. La consommation d'alcool, de drogues ou de médicaments avant ou pendant l'utilisation du spa peut entraîner une perte de conscience avec possibilité de noyade.
- e) Obese persons and persons with a history of heart disease, low or high blood pressure, circulatory system problems, or diabetes should consult a physician before using a spa. Les personnes obèses et les personnes ayant des antécédents de maladie cardiaque, d'hypotension ou d'hypertension artérielle, des problèmes de système circulatoire ou de diabète devraient consulter un médecin avant d'utiliser un spa.
- f) Persons using medication should consult a physician before using a spa since some medication may induce drowsiness while other medication may affect heart rate, blood pressure, and circulation. Les personnes qui prennent des médicaments devraient consulter un médecin avant d'utiliser un spa, car certains médicaments peuvent provoquer de la somnolence tandis que d'autres médicaments peuvent affecter la fréquence cardiaque, la pression artérielle et la circulation.

DANGER: RISK OF INJURY: The suction fittings in this spa are sized to match the specific water flow created by the pump. Should the need arise to replace the suction fittings or the pump, be sure that the flow rates are compatible. Never operate spa if the suction fittings are broken or missing. Never replace a suction fitting with one rated less than the flow rate marked on the original suction fitting.

DANGER: RISQUE DE BLESSURE: Les raccords d'aspiration de ce spa sont dimensionnés pour correspondre au débit d'eau spécifique créé par la pompe. En cas de besoin de remplacement des raccords d'aspiration ou de la pompe, assurez-vous que les débits sont compatibles. N'utilisez jamais le spa si les raccords d'aspiration sont cassés ou manquants. Ne remplacez jamais un raccord d'aspiration par un autre de moins que le débit indiqué sur le raccord d'aspiration d'origine.

DANGER: **RISK OF ACCIDENTAL DROWNING:** Extreme caution must be exercised to prevent unauthorized access by children. To avoid accidents, ensure that children cannot use this spa unless they are supervised at all times.

DANGER: **RISQUE DE NOYADE ACCIDENTELLE:** Une extrême prudence doit être exercée pour empêcher tout accès non autorisé aux enfants. Pour éviter les accidents, assurez-vous que les enfants ne peuvent pas utiliser ce spa à moins qu'ils ne soient surveillés en tout temps.

DANGER: **RISK OF ELECTRIC SHOCK:** Install at least 5 feet (1.5 m) from all metal surfaces. As an alternative, a spa may be installed within 5 feet of metal surfaces if each metal surface is permanently connected by a minimum 8 AWG (8.4 mm²) solid copper conductor to the wire connector on the terminal box that is provided for this purpose.

DANGER: **RISQUE DE CHOC ÉLECTRIQUE:** Installez à au moins 1,5 m (5 pieds) de toutes les surfaces métalliques. Comme alternative, un spa peut être installé à moins de 1,5 m des surfaces métalliques si chaque surface métallique est connectée en permanence par un conducteur en cuivre massif d'au moins 8,4 mm² (8 AWG) au connecteur de fil sur la boîte à bornes qui est fourni à cet effet.

A wire connector is provided on this unit to connect a minimum 8 AWG (8.4 mm²) solid copper conductor between this unit and any metal equipment, metal enclosures of electrical equipment, metal water pipe, or conduit within 5 feet (1.5 m) of the unit. Un connecteur de fil est fourni sur cette unité pour connecter un conducteur en cuivre solide d'au moins 8,4 mm² (8 AWG) entre cette unité et tout équipement métallique, les boîtiers métalliques de l'équipement électrique, la conduite d'eau métallique ou le conduit à moins de 1,5 m (5 pieds) de l'unité.

DANGER: **RISK OF ELECTRIC SHOCK:** Do not permit any electric appliance, such as a light, telephone, radio, or television, within 5 feet (1.5 m) of a spa.

DANGER: **RISQUE DE CHOC ÉLECTRIQUE:** Ne laissez aucun appareil électrique, comme une lampe, un téléphone, une radio ou une télévision, à moins de 1,5 m (5 pieds) d'un spa.

WARNING: CHILDREN SHOULD NOT USE SPAS OR HOT TUBS WITHOUT ADULT SUPERVISION.

AVERTISSEMENT: NE PAS LAISSER LES ENFANTS UTILISER UNE CUVE DE RELAXATION SANS SURVEILLANCE.

WARNING: DO NOT USE SPAS OR HOT TUBS UNLESS ALL SUCTION GUARDS ARE INSTALLED TO PREVENT BODY AND HAIR ENTRAPMENT.

AVERTISSEMENT: POUR ÉVITER QUE LES CHEVEUX OU UNE PARTIE DU CORPS PUISSENT ÊTRE ASPIRÉS, NE PAS UTILISER UNE CUVE DE RELAXATION SI LES GRILLES DE PRISE D'ASPIRATION NE SONT PAS TOUTES EN PLACE.

WARNING: PEOPLE USING MEDICATIONS AND/OR HAVING AN ADVERSE MEDICAL HISTORY SHOULD CONSULT A PHYSICIAN BEFORE USING A SPA OR HOT TUB.

AVERTISSEMENT: LES PERSONNES QUI PRENNENT DES MÉDICAMENTS ET (OU) ONT DES PROBLÈMES DE SANTÉ DEVRAIENT CONSULTER UN MÉDECIN AVANT D'UTILISER UNE CUVE DE RELAXATION.

WARNING: PEOPLE WITH INFECTIOUS DISEASES SHOULD NOT USE A SPA OR HOT TUB.

AVERTISSEMENT: LES PERSONNES ATTEINTES DE MALADIES INFECTIEUSES NE DEVRAIENT PAS UTILISER UNE CUVE DE RELAXATION.

- WARNING:** TO AVOID INJURY, EXERCISE CARE WHEN ENTERING OR EXITING THE SPA OR HOT TUB.
- AVERTISSEMENT:** POUR ÉVITER DES BLESSURES, USER DE PRUDENCE EN ENTRANT DANS UNE CUVE DE RELAXATION ET EN SORTANT.
- WARNING:** DO NOT USE DRUGS OR ALCOHOL BEFORE OR DURING THE USE OF A SPA OR HOT TUB TO AVOID UNCONSCIOUSNESS AND POSSIBLE DROWNING.
- AVERTISSEMENT:** POUR ÉVITER L'ÉVANOUISSEMENT ET LA NOYADE ÉVENTUELLE, NE PRENDRE NI DROGUE NI ALCOOL AVANT D'UTILISER UNE CUVE DE RELAXATION NI QUAND ON S'Y TROUVE.
- WARNING:** THE USE OF ALCOHOL OR DRUGS CAN GREATLY INCREASE THE RISK OF FATAL HYPERTHERMIA IN HOT TUBS AND SPAS.
- AVERTISSEMENT:** LA CONSOMMATION D'ALCOOL OU DE DROGUE AUGMENTE CONSIDÉRABLEMENT LES RISQUES D'HYPERTHERMIE MORTELLE DANS UNE CUVE DE RELAXATION.
- WARNING:** PREGNANT OR POSSIBLY PREGNANT WOMEN SHOULD CONSULT A PHYSICIAN BEFORE USING A SPA OR HOT TUB.
- AVERTISSEMENT:** LES FEMMES ENCEINTES, QUE LEUR GROSSESSE SOIT CONFIRMÉE OU NON, DEVRAIENT CONSULTER UN MÉDECIN AVANT D'UTILISER UNE CUVE DE RELAXATION.
- WARNING:** WATER TEMPERATURE IN EXCESS OF 100 °F (38 °C) CAN BE INJURIOUS TO YOUR HEALTH.
- AVERTISSEMENT:** IL PEUT ÊTRE DANGEREUX POUR LA SANTÉ DE SE PLONGER DANS DE L'EAU À PLUS DE 38 °C (100 °F).
- WARNING:** BEFORE ENTERING THE SPA OR HOT TUB, MEASURE THE WATER TEMPERATURE WITH AN ACCURATE THERMOMETER.
- AVERTISSEMENT:** AVANT D'UTILISER UNE CUVE DE RELAXATION, MESURER LA TEMPÉRATURE DE L'EAU À L'AIDE D'UN THERMOMÈTRE PRÉCIS.
- WARNING:** DO NOT USE A SPA OR HOT TUB IMMEDIATELY FOLLOWING STRENUOUS EXERCISE.
- AVERTISSEMENT:** NE PAS UTILISER UNE CUVE DE RELAXATION IMMÉDIATEMENT APRÈS UN EXERCICE FATIGANT.
- WARNING:** PROLONGED IMMERSION IN A SPA OR HOT TUB CAN BE INJURIOUS TO YOUR HEALTH.
- AVERTISSEMENT:** L'UTILISATION PROLONGÉE D'UNE CUVE DE RELAXATION PEUT ÊTRE DANGEREUSE POUR LA SANTÉ.
- WARNING:** DO NOT PERMIT ELECTRIC APPLIANCES (SUCH AS A LIGHT, TELEPHONE, RADIO, OR TELEVISION) WITHIN 5 FEET (1.5 M) OF THIS SPA OR HOT TUB.
- AVERTISSEMENT:** NE PAS PLACER D'APPAREIL ÉLECTRIQUE (LUMINAIRE, TÉLÉPHONE, RADIO, TÉLÉVISEUR, ETC) À MOINS DE 1.5 M (5 PIEDS) DE CETTE CUVE DE RELAXATION.
- CAUTION:** MAINTAIN WATER CHEMISTRY IN ACCORDANCE WITH MANUFACTURER'S INSTRUCTIONS.
- ATTENTION:** LA TENEUR DE L'EAU EN MATIÈRES DISSOUTES DOIT ÊTRE CONFORME AUX DIRECTIVES DU FABRICANT.

Hyperthermia occurs when the internal temperature of the body reaches a level several degrees above the normal body temperature of 98.6 °F (37 °C). The symptoms of hyperthermia include drowsiness, lethargy, and an increase in the internal temperature of the body. The effects of hyperthermia include. L'hyperthermie se produit lorsque la température interne du corps atteint un niveau supérieur de plusieurs degrés à la température corporelle normale de 37 °C (98.6 °F). Les symptômes de l'hyperthermie comprennent la somnolence, la léthargie et une augmentation de la température interne du corps. Les effets de l'hyperthermie comprennent.

- a) unawareness of impending hazard/ méconnaissance d'un danger imminent.
- b) failure to perceive heat/ incapacité à percevoir la chaleur.
- c) failure to recognize the need to exit spa/ incapacité à reconnaître la nécessité de quitter le spa.
- d) physical inability to exit spa/ incapacité physique de quitter le spa.
- e) fetal damage in pregnant women/ dommages foetaux chez les femmes enceintes.
- f) unconsciousness and danger of drowning/ inconscience et danger de noyade.

Suction Outlet Fitting Safety Instructions

When installing and using this equipment, basic safety precautions shall always be followed including the following IMPORTANT SAFETY INSTRUCTIONS.

WARNING: Any modification that increases the flow rate of the circulation system shall require re-evaluation of the cover/grate and sump to ensure that the flow rating of the suction outlet fitting is not exceeded.

WARNING: Missing, broken, or cracked cover/grates, sumps, mud frames, or any other suction outlet fitting component shall be replaced before bathers are allowed to use the unit.

WARNING: Loose cover/grates shall be reattached before bathers are allowed to use the unit.

Suction Outlet Fitting User Maintenance Instructions

Field Modifications:

Any field modification made to the suction outlet fitting not authorized by Endless Pools installation instructions shall void the suction outlet fitting assembly certification.

Configuration Modifications:

No modification shall be made to a suction outlet fitting structure or flow path unless the new configuration has been certified as a new suction outlet fitting assembly.

Service Life:

The suction outlet fitting is constructed of 316L perforated stainless steel. It shall be replaced after 25 years of use using a #2 Phillips head screwdriver. The suction outlet fitting shall be replaced at or before the end of the service life. The service life of the suction outlet fitting begins the month and year in which the suction outlet fitting is installed with or without water.

Service Instructions:

If service is required to inspect, repair, or replace the suction outlet fitting, it shall be done so with a #2 Phillips head screwdriver. DO NOT USE POWER TOOLS TO INSTALL FASTENERS. Start installation of screws by hand to ensure proper thread engagement and to prevent cross threading. REFER TO "SUCTION OUTLET FITTING SERVICE INSTRUCTIONS" FOR ANY SERVICE REQUIRED TO REPAIR OR REPLACE ANY SUCTION OUTLET FITTING COMPONENT OR FASTENER.

1. Hand check the suction outlet fitting after installation to verify that it's snug.
2. Before each use, verify the suction outlet fitting including the fasteners, are undamaged and have not been tampered with.
3. Any missing, broken, or cracked suction outlet fitting shall be replaced before using.
4. A loose suction outlet fitting and associated components shall be reattached before using.
5. The suction outlet fitting components and fastener receptacles shall be clean and free of debris or obstructions during the installation.

SAVE THESE INSTRUCTIONS. CONSERVEZ CES INSTRUCTIONS.

Fastlane Pro Information

The Endless Pool Fastlane Pro is ETL listed, Ref. # 2001779 and is evaluated to UL 1563 and CSA 22.2 NO. 218.1-13. Individually, all electrical components of the Endless Pool are UL and/or CSA approved.

All electrical connections should be made by a licensed electrician in accordance with the current national and local electrical codes.

Please read this Owner's Manual prior to beginning your project.

Installation Instructions Table of Contents

General Overview Of Fastlane Pro	7	Electrical Requirements for the United States	39
Choosing A Location For Your Fastlane Pro	8	Electrical Requirements for the UK	40
Receiving Your Fastlane Pro	8	Equipment Startup	41
Wall Mount Bracket	9	Bonding The Fastlane Pro	42
Gunite Pool	9	Wall Mount Fastlane Pro Bonding	43
Steel/Polymer Pool with a Vinyl Liner	13	Deck Mount Fastlane Pro Bonding	44
Gunite Pool with a Vinyl Liner	18	Using Your Fastlane Pro	46
Fiberglass Pool	23	Product Installation Information	46
Junction Box And 1/2" Run Hoses	27	General Information	46
Assembly Of The Fastlane Pro Swim Unit	28	Scheduled Maintenance	47
Installation Of Your Wall Mount Fastlane Pro	34	Suction Outlet Fitting Service Instructions	48
Deck Mount Fastlane Pro Hose Cover Tray Installation	35		
Deck Mount Fastlane Pro Installation	36		
Installation Of The Hydraulic Power Unit	38		

Section 1

GENERAL OVERVIEW OF AN ENDLESS POOL FASTLANE PRO

The Fastlane Pro swimming machine by Endless Pools is a hydraulically-powered system that creates a smooth, adjustable-speed swim current in a conventional pool. The Fastlane Pro has been fabricated with the finest, most durable materials and designed to meet the most stringent safety standards including VGB 2008. The swim current produced is wider than your body and deeper than your stroke — far superior to currents created by one or more jets. Two 3/8" (9,5mm) hydraulic hoses carrying a non-food grade, biodegradable vegetable oil run between the hydraulic Power Unit and the Fastlane Pro Swim Unit, thus eliminating the need for electricity poolside. When pumped at high pressure, this hydraulic fluid creates a swim current by turning the shaft of a submerged stainless steel hydraulic motor in the Fastlane Pro Swim Unit, which in turn rotates a 16" (40,6cm) diameter propeller. The Power Unit is activated using a 3-button radio frequency remote control that can turn the unit on and off and adjust the speed. It is best if the Power Unit is within 25' (7,6m) of the Swim Unit to minimize pressure loss. An optional 6" (15,2cm) LED swim pace display is available to monitor your speed.

Note: All of the 316L stainless steel screws provided for the assembly of this unit should be tightened to the recommended 25 in-lbs of torque.

W = Wall Mount Fastlane Pro

D = Deck Mount Fastlane Pro

The Fastlane Pro can be mounted one of two ways:

The Wall Mount Fastlane Pro fastens to the wall of the pool using the bracket provided. Two 1 1/2" (38mm) PVC pipes which serve as conduits for the hydraulic hoses run under the pool deck to a remotely located, 5-horsepower, hydraulic Power Unit, as shown in Figure 1.1.

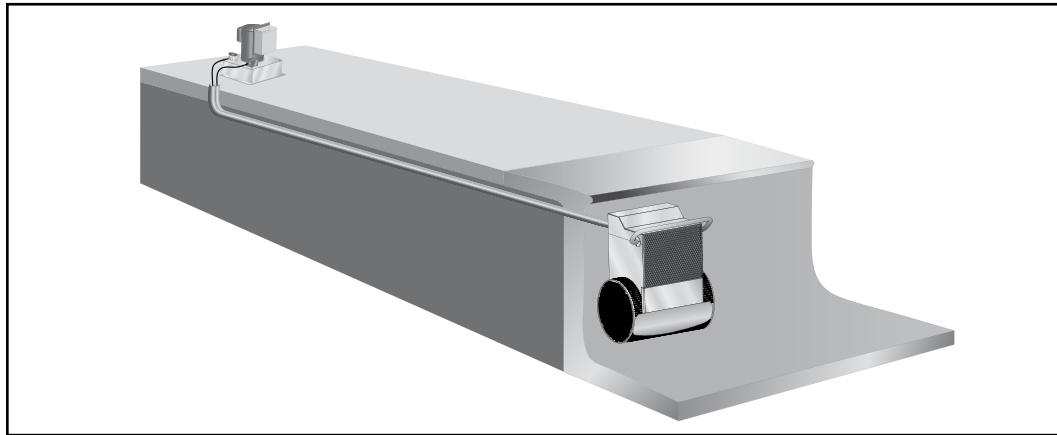

Fig. 1.1

The Deck Mount Fastlane Pro fastens to the pool deck using the hanger bracket provided. The two hydraulic lines then run back to the remotely located, 5-horsepower, hydraulic Power Unit. The hydraulic hoses can be run through a conduit or run aboveground, as shown in Figure 1.2.

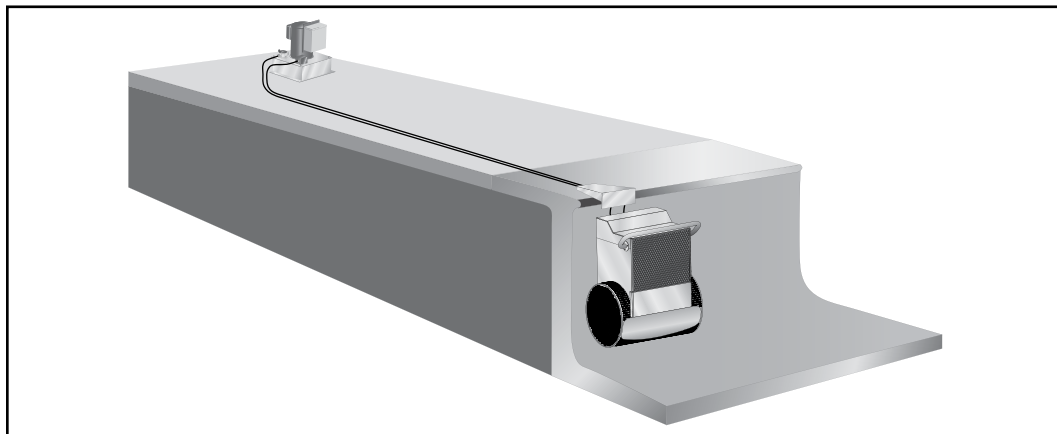

Fig. 1.2

Section 2

CHOOSING A LOCATION FOR YOUR FASTLANE PRO

The Fastlane Pro can fit in virtually any swimming pool. For optimal water flow, we recommend that you allow at least 12 feet (3,7m) between the wall on which the Fastlane Pro is installed and the opposing wall in line with the Swim Unit. The Fastlane Pro has more than 9 square feet (.83m²) of water intake to eliminate any entrapment hazards. The water depth where the Fastlane Pro is installed must be at least 39" (99cm) deep. In addition, the Fastlane Pro must be installed no closer than 24" (61cm) from any adjacent wall as shown in Figure 2.1, Minimum Clearance Guidelines.

When choosing a location for your Fastlane Pro, you should also consider the route for the hydraulic hoses to run back to the Power Unit. The Power Unit needs to sit on a solid, level surface, preferably not on wet ground, and requires a 30-amp, 220-volt GFCI electric service. For UK and international electrical requirements, please refer to Section 11. The optional Outdoor Power Unit with Weather Guard may be located outside, but should not be subject to driving rain. Typically, the Power Unit is located with the other pool equipment and, if possible, long hydraulic runs should be avoided because of pressure loss. If you wish to have a run greater than 25' (7,6m), you must transition from 3/8" (9,5mm) hydraulic hoses to 1/2" (12,7mm) run hoses with the addition of a junction box as reviewed in Section 5.

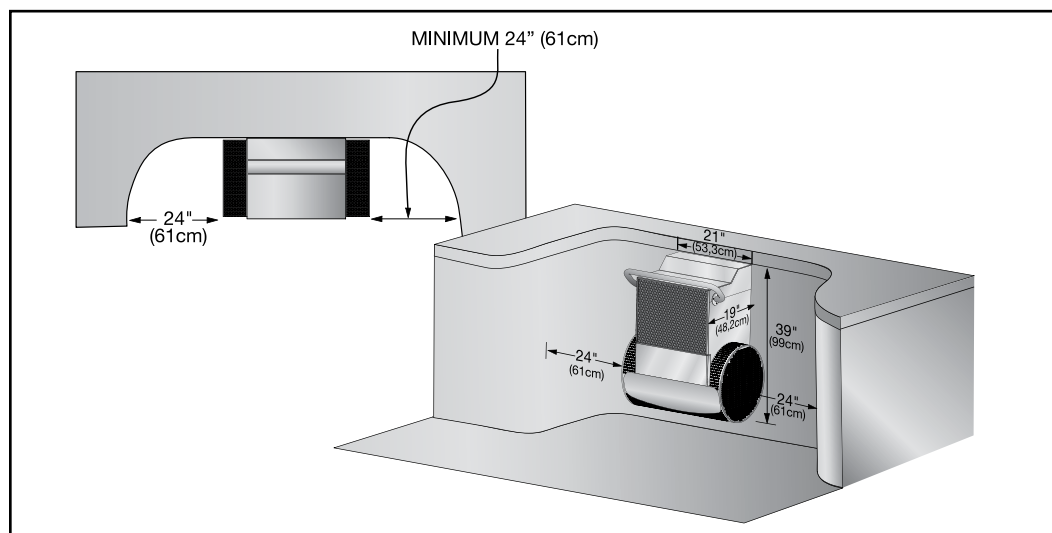

Fig. 2.1 Minimum Clearance Guide

Section 3

RECEIVING YOUR FASTLANE PRO

The Endless Pools Fastlane Pro is comprised of a minimum of six (6) parcels. Additional parcels may be shipped as appropriate. All items will be shipped via UPS Ground.

Items shipped UPS

Parcel 1: Fastlane Pro Propulsion Housing Kit

Parcel 2: Fastlane Pro Propulsion Base Kit

Parcel 3: Hydraulic Power Unit (wireless remote controls and antenna kit located inside controller)

Parcel 4: Hydraulic Fluid (5 Gallon container)

Wall Mount Fastlane Pro

Parcel 5: Wall Mount Fastlane Pro Mounting Kit (wall mount bracket and hardware for wall mount kit)

Parcel 6: Accessory Kit for Fastlane Pro (hat sections, propulsion housing lid, hardware kit for Fastlane Pro assembly)

Deck Mount Fastlane Pro

Parcel 5: Accessory Kit for Fastlane Pro (hat sections, propulsion housing lid, hardware kit for Fastlane Pro assembly)

Bracket Kit for Deck Mount Fastlane Pro (hanging bracket, deck plate, hardware for bracket kit)

Optional Equipment

Weather Guard

Floor Mirror

Swim Pace Display

Wi-Fi Kit (included in the accessory kit if purchased)

Section 4

WALL MOUNT BRACKET

Note: Please read instructions fully prior to installing the wall mount bracket.

4.A. Gunite Pool

If the pool being constructed is gunite, please follow the instructions below.

The Wall Mount Fastlane Pro Mounting Kit for Gunite pools includes the following:
(refer to Fig 4.1)

- (1) PVC Wall Bracket
- (2) Bonding Clamp
- (2) 3/8" (9,5mm) Stainless Steel Threaded Mounting Rod
- (6) 3/8" (9,5mm) Stainless Steel Jam Nut
- (6) 3/8" (9,5mm) Stainless Steel Flat Washer
- (2) 3/8" (9,5mm) Stainless Steel Lock Washer
- (2) 1-1/2" (38mm) Thru-Wall Fitting
- (2) 1-1/2" (38mm) MPT x 1" (25mm) FPT Bushing Reducer
- (2) 1" (25mm) Liquid Tight Fitting

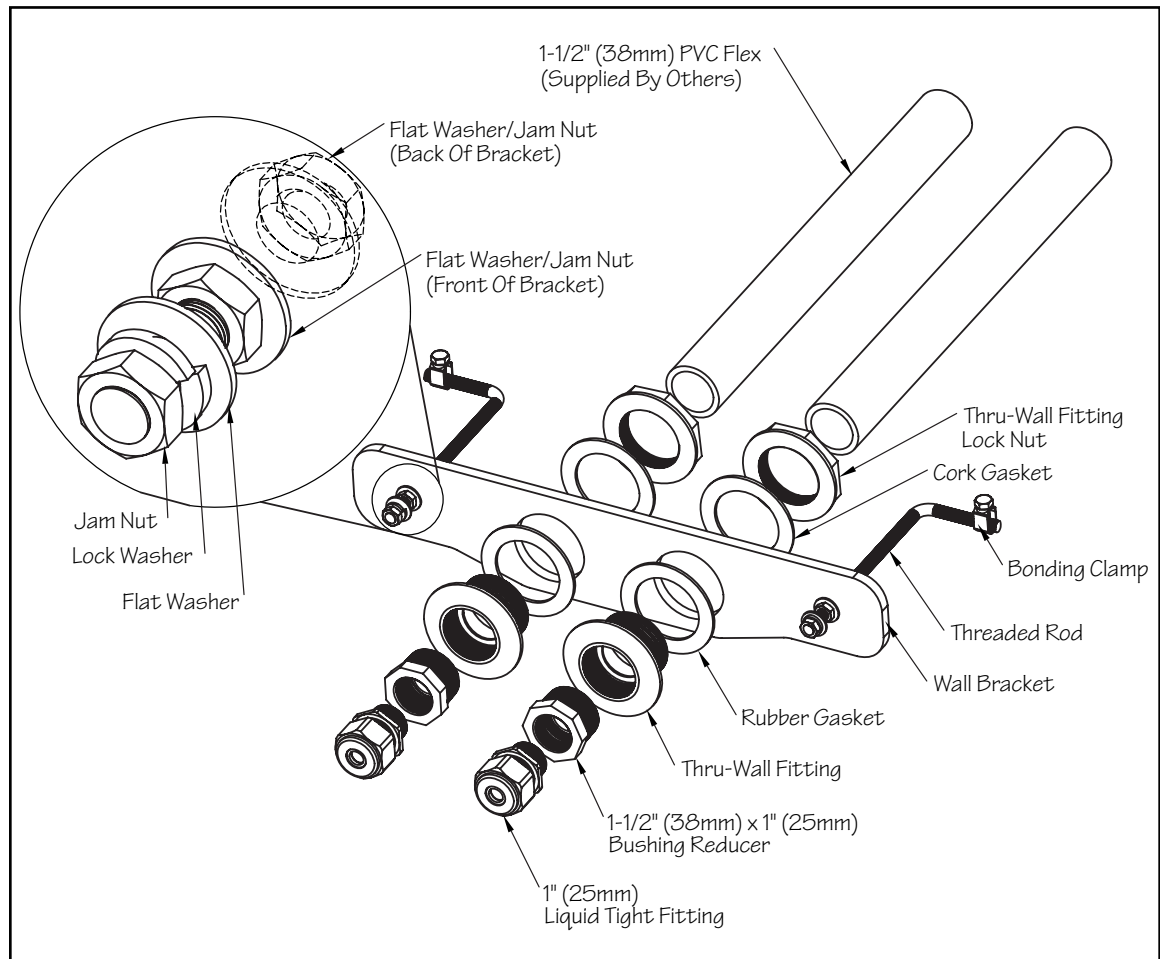

Fig. 4.1

Secure the thru-wall fittings to the bracket as shown in Fig 4.1. The rubber gasket should be between the thru-wall and the bracket on the poolside of the bracket and the cork gasket should be between the bracket and the locknut on the outside. Tighten the lock nut with a pair of channel locks or strap wrench.

The bracket is to be installed into the pool wall as shown in Figure 4.2 so that the two threaded mounting rods are 1-1/2" (38mm) above the intended waterline for the pool, which is typically halfway up the skimmer. The "Waterline" mark on the bracket will sit along the pool's intended waterline.

Level and position the bracket so that the PVC surface of the bracket will be flush with the finished surface of the pool wall as shown in Figures 4.2. and 4.5. The area below the bracket should be no more than 5 degrees less than the vertical down to at least 39" (99cm) below the waterline. The Fastlane Pro is 21" (53,3cm) wide. Consequently, the 21" (53,3cm) section of wall where the bracket is located should be straight or near straight.

The threaded rods attached to the bracket must be tied back to the rebar of the pool with rebar wire. Once encased in concrete, these rods will serve as a suitable hanger. The threaded rods must penetrate 1-1/4" to 1-1/2" (31,8mm x 38mm) into the finished pool and will be used to hang the Fastlane Pro

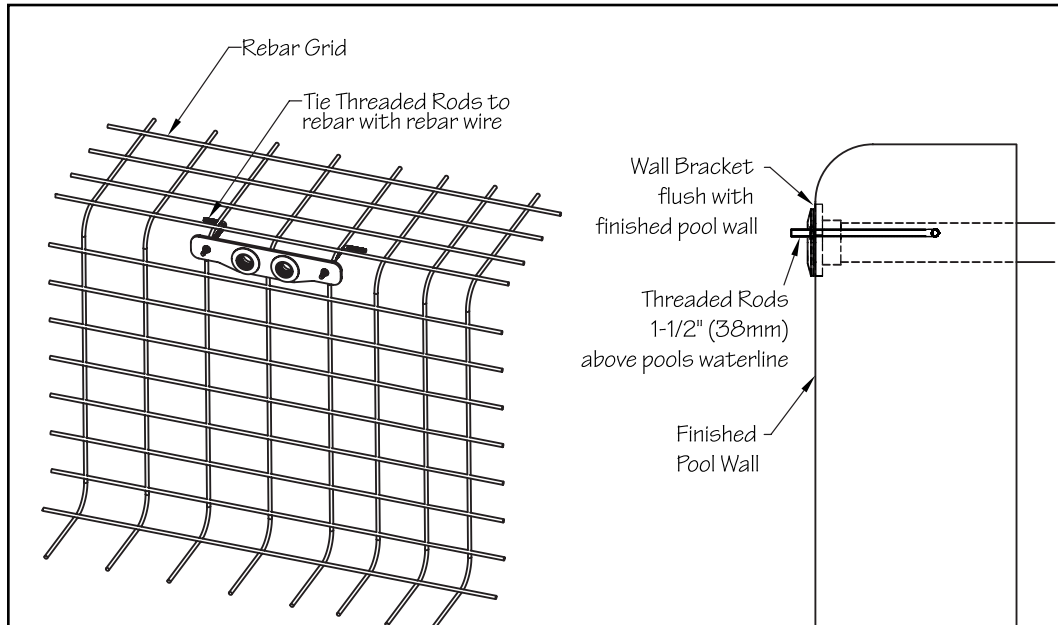

Fig. 4.2

The location of the Hydraulic Power Unit should be determined at this point in the installation. Unroll lengths of 1-1/2" (38mm) flexible PVC pipe from the back of the wall mount bracket to the Power Unit. Any bends in the flexible pipe **MUST** be gradual sweeps and not sharp to allow the hydraulic hoses to easily be fed through each conduit.

If the Hydraulic Power Unit is within 25' (7,6m) of the pool: Each length of flexible pipe should exit the ground within 4' (1,2m) of the Power Unit. Approximately 4' (1,2m) of hydraulic hose is required to make the hydraulic connections at the Power Unit.

If the Hydraulic Power Unit is more than 25' (7,6m) away from pool: 25' (7,6m) of flexible pipe, a junction box, and an additional length of flexible pipe **MUST** be employed. It is at the junction box where a step up to a larger diameter hydraulic hose occurs to reduce pressure loss and a potential reduction in performance. In this case, the length of flexible pipe between the wall mount bracket and junction box **MUST** be 24' 6" (7,5m). This will allow the hydraulic hoses to terminate just inside the junction box. An additional length of flexible pipe coming out of the junction box should exit the ground within 4' (1,2m) of the Power Unit. See Section 5: Junction Box for detailed information.

Glue the lengths of flexible pipe into the thru-wall fittings on the backside of the wall mount bracket (Fig 4.3).

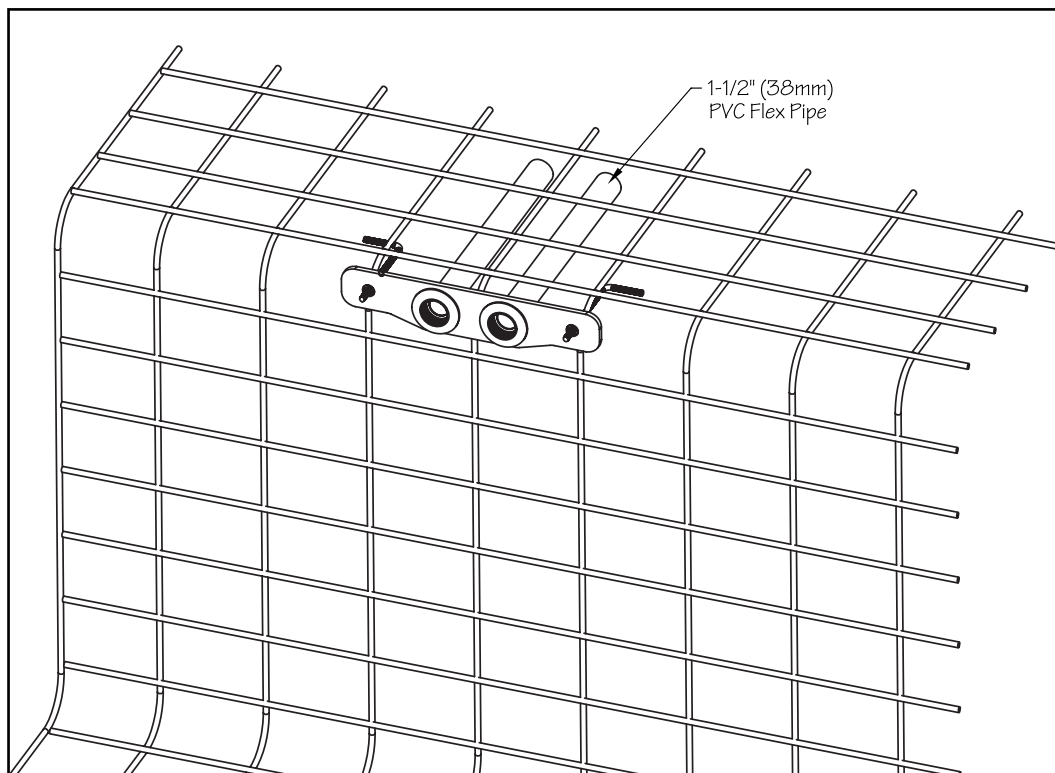

Fig. 4.3

The threaded rods must be tied into the pools bonding grid. Secure a bonding clamp to each threaded rod. Attach a #8 solid copper wire to each bonding clamp. These wires **MUST** be attached to a bonding connection that's incorporated into the pools bonding grid. In most cases this will be a connection at the rebar. Verify ALL bonding connections are tight before shooting gunite (Fig 4.4).

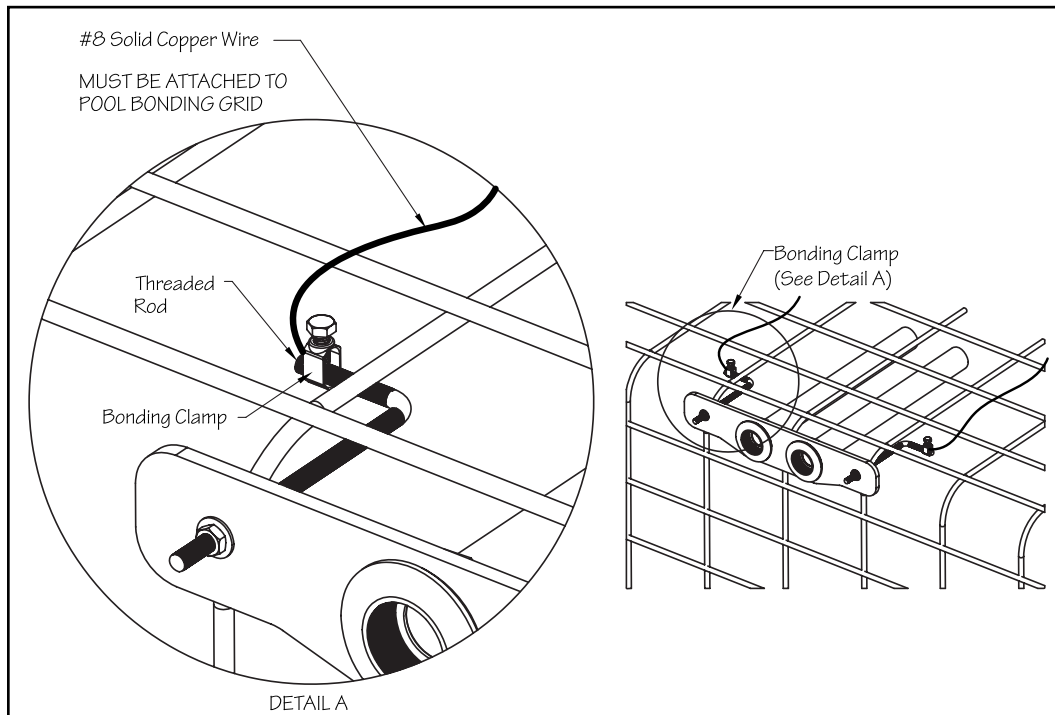

Fig. 4.4

Prior to shooting gunite, it is critical that the opening of each thru-wall and the threaded rods that extend into the finished pool be covered. No gunite can be embedded in these areas.

After verifying the bracket is positioned, bonding connections are secure, and thru-wall openings/threaded rods are covered, gunite can be shot (Fig 4.5).

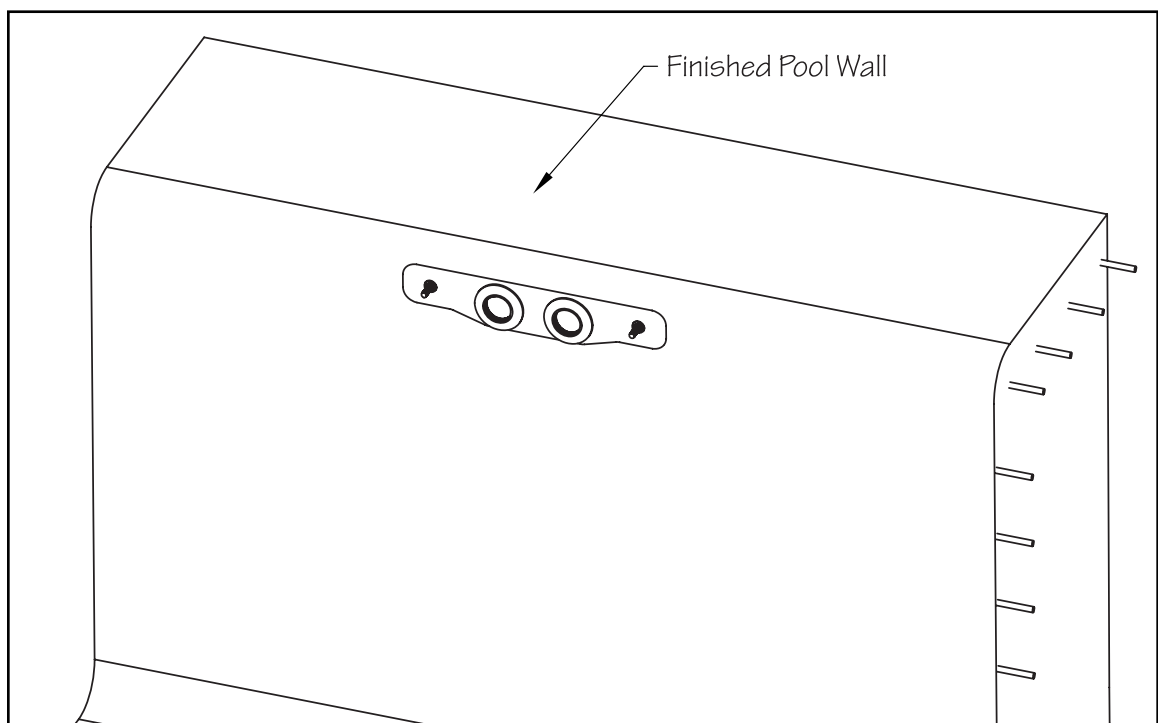

Fig. 4.5

4.B. Steel/Polymer Pool with a Vinyl Liner

If the pool being constructed is a steel or polymer pool with a vinyl liner, please follow the instructions below.

The Wall Mount Fastlane Pro Mounting Kit for steel/polymer/gunite pools with a vinyl liner includes the following:

- (1) PVC Wall Bracket
- (2) Bonding Clamp
- (2) 3/8" (9,5mm) Stainless Steel Threaded Mounting Rod
- (2) 3/8" (9,5mm) Stainless Steel Coupler
- (2) 3/8" (9,5mm) Stainless Steel Threaded Stud
- (4) 3/8" (9,5mm) Stainless Steel Jam Nut
- (2) 3/8" (9,5mm) Stainless Steel Flat Washer
- (2) 3/8" (9,5mm) Stainless Steel Lock Washer
- (2) 3/8" (9,5mm) Rubber Washer
- (2) 3/8" (9,5mm) Stainless Steel with Neoprene (Sacrificial Washer)
- (2) 3/8" (9,5mm) Stainless Steel Hex Head Bolt (Sacrificial Bolt)
- (2) 1-1/2" (38mm) Star Thru-Wall Fitting
- (2) 1-1/2" (38mm) MPT x FSlip Adapter
- (2) 1-1/2" (38mm) MPT x 1" (25mm) FPT Bushing Reducer
- (2) 1" (25mm) Liquid Tight Fitting
- (1) Clear Silicone

Position the PVC template where the Fastlane Pro will attach to the pool wall and align the bottom of the template with the expected water level in the pool (which will typically be located at the centerline of the skimmer) as shown in Figure 4.6. Use duct tape to temporarily adhere the PVC template to the pool wall. Be certain that the PVC template is level in the pool. Trace the outline of the star thru-wall fittings and threaded rod hole penetrations that are cut in the PVC template onto the pool wall. Remove the PVC template from the pool wall. Cut or punch the openings for the star thru-wall fittings and threaded rod holes.

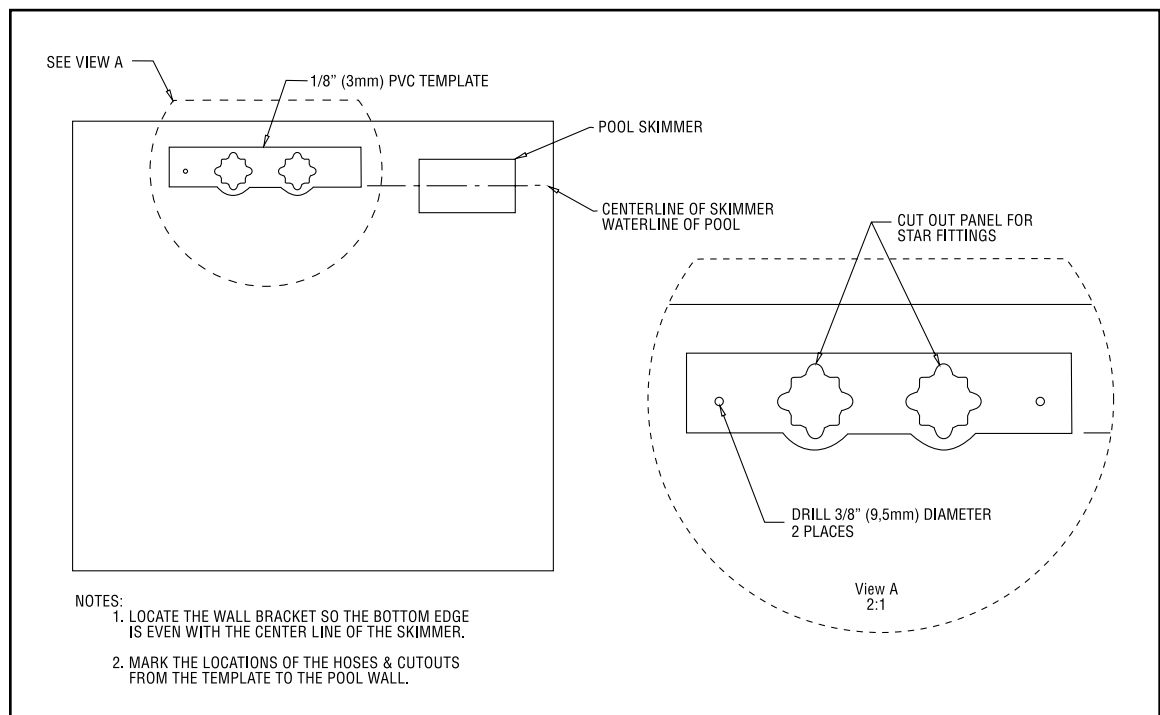

Fig. 4.6

Install the star thru-wall fittings with the holes for the cover at 12, 3, 6, and 9 (clock positions) as shown in Figure 4.7

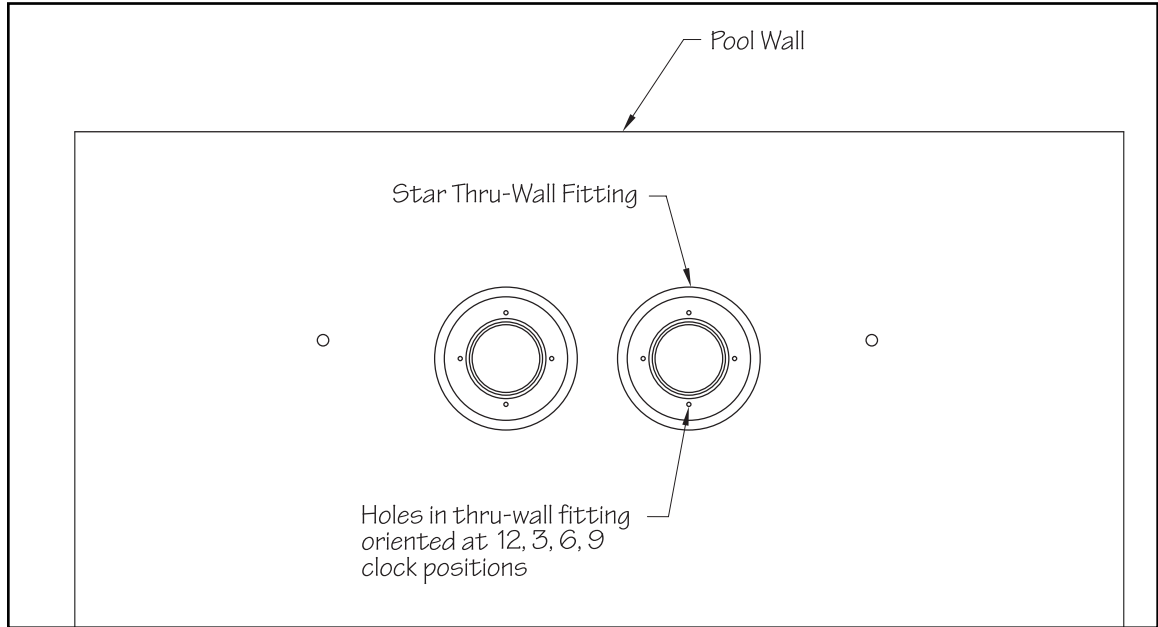

Fig. 4.7

Thread the 3/8" (9,5mm) jam nut onto the threaded rod. Thread the hex coupling onto the threaded rod so that half of the hex coupling is threaded onto the rod and the other half that's facing the pool is protruding off the threaded rod. Tighten the jam nut so that its flush with the hex coupling to prevent the hex coupling from threading further onto the rod. On the outside of the pool (backside of the pool wall), position each rod and hex coupling to align with the 3/8" (9,5mm) holes drilled (Fig 4.8).

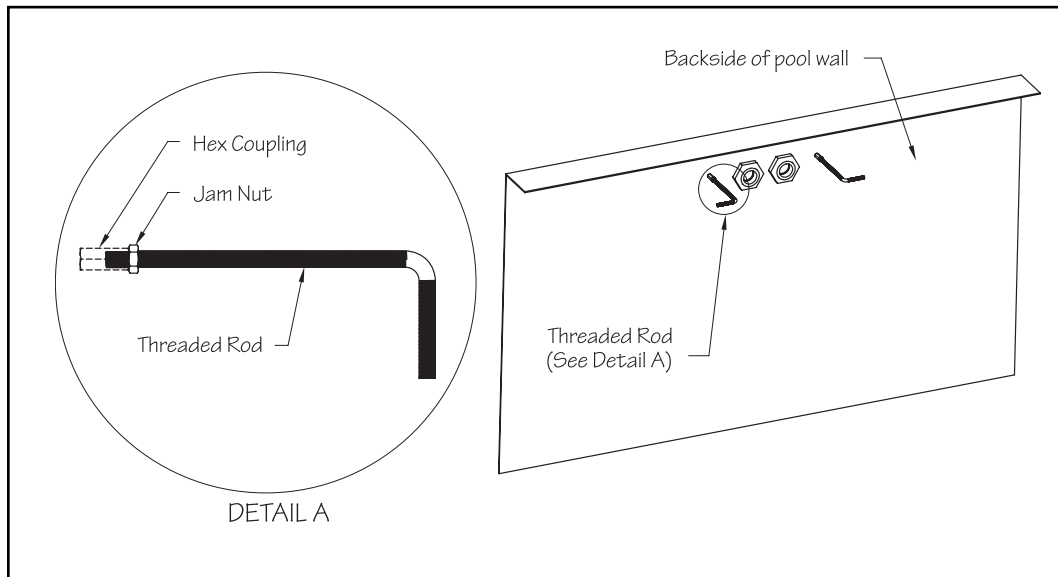

Fig. 4.8

On the inside of the pool, thread the sacrificial 3/8" (9,5mm) steel (with rubber washer) and bolt into the hex coupling through the hole that was previously drilled in the steel wall. Tighten the bolt to secure the assembly (Fig 4.9).

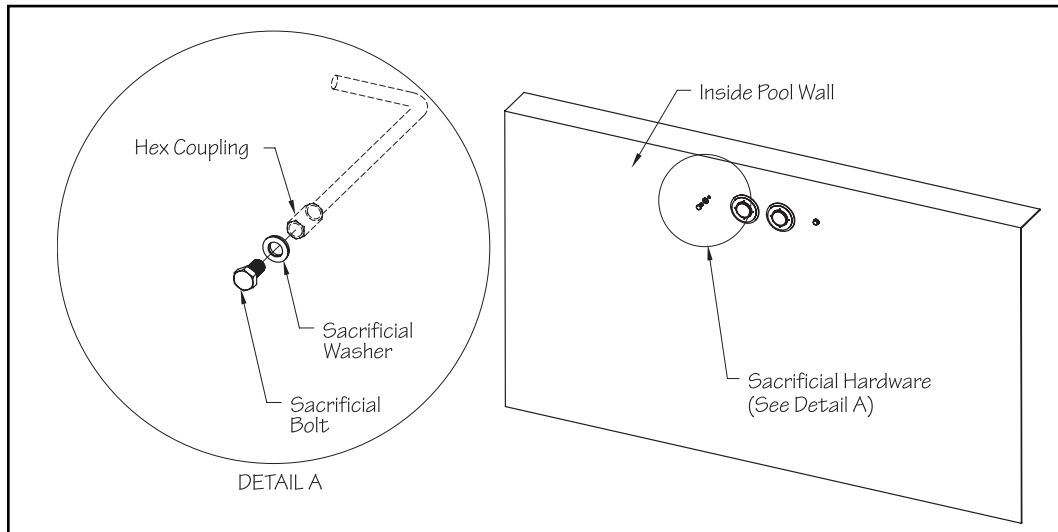

Fig. 4.9

The location of the Hydraulic Power Unit should be determined at this point in the installation. Unroll lengths of 1-1/2" (38mm) flexible PVC pipe from the back of the wall mount bracket to the Power Unit. Any bends in the flexible pipe **MUST** be gradual sweeps and not sharp to allow the hydraulic hoses to easily be fed through each conduit.

If the Hydraulic Power Unit is within 25' (7,6m) of the pool: Each length of flexible pipe should exit the ground within 4' (1,2m) of the Power Unit. Approximately 4' (1,2m) of hydraulic hose is required to make the hydraulic connections at the Power Unit.

If the Hydraulic Power Unit is more than 25' (7,6m) away from pool: 25' (7,6m) of flexible pipe, a junction box, and an additional length of flexible pipe **MUST** be employed. It is at the junction box where a step up to a larger diameter hydraulic hose occurs to reduce pressure loss and a potential reduction in performance. In this case, the length of flexible pipe between the wall mount bracket and junction box **MUST** be 24' 6" (7,5m). This will allow the hydraulic hoses to terminate just inside the junction box. An additional length of flexible pipe coming out of the junction box should exit the ground within 4' (1,2m) of the Power Unit. See Section 5: Junction Box for detailed information.

Apply Teflon thread sealant to the threads of the 1-1/2" (38mm) MPT x FSLIP adapters and thread them into the thru-wall fittings on the backside of the wall mount bracket. Glue the lengths of flexible pipe into the adapters (Fig 4.10).

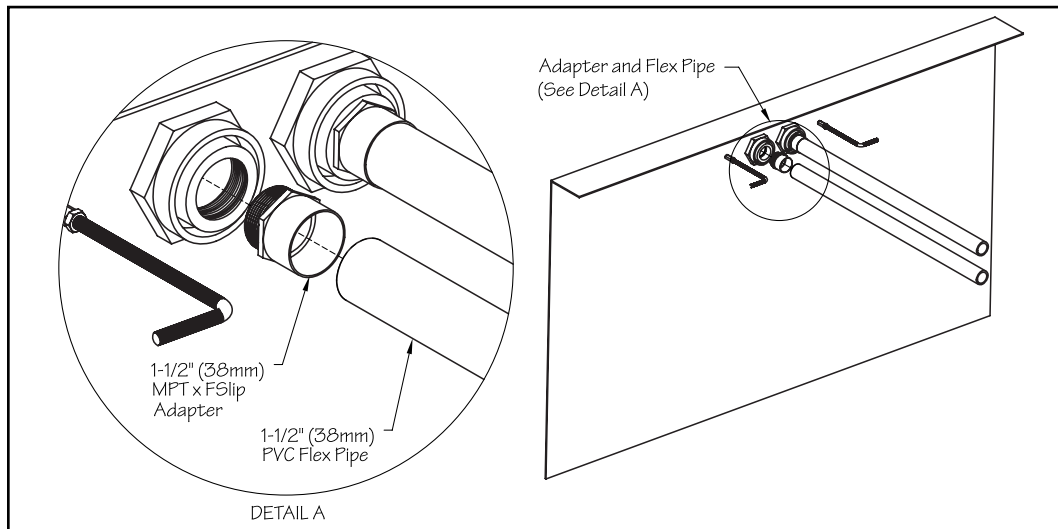

Fig. 4.10

The threaded rods must be tied into the pools bonding grid. If using rebar in the pools concrete collar, tie the threaded rods to the rebar using rebar wire. Secure a bonding clamp to each threaded rod. Attach a #8 solid copper wire to each bonding clamp. These wires **MUST** be attached to a bonding connection that's incorporated into the pools bonding grid. In most cases this connection will be at the pools existing equipment (heater, pump, etc.) that's presumably already tied into the bonding grid of the pool. Verify these connections are tight before pouring concrete (Fig 4.11)

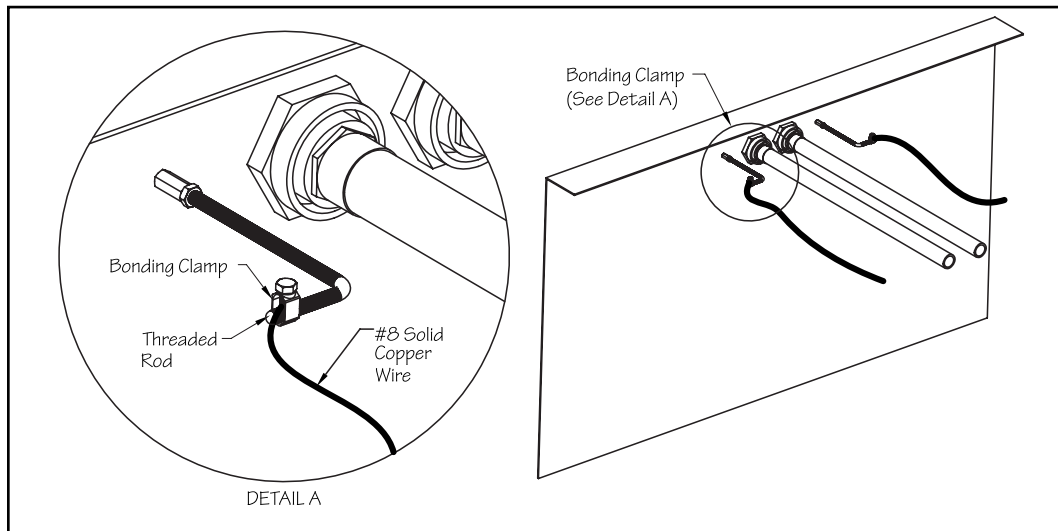

Fig. 4.11

Prior to pouring concrete, it is critical that the opening of each thru-wall and the sacrificial bolt be covered. No concrete can be embedded in these areas. Pour the concrete collar around the top flange of the pool encasing the threaded rods and conduit in place. This encasement will help secure the Fastlane Pro (Fig 4.12).

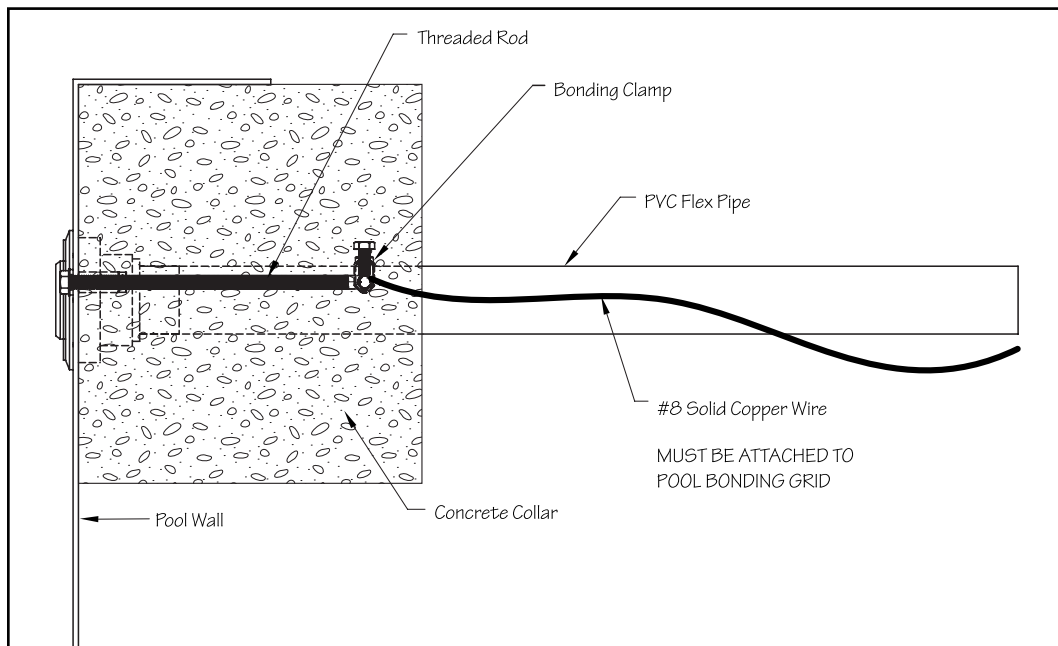

Fig. 4.12

After the concrete has cured remove the sacrificial 3/8" (9,5mm) washers and bolts and install the pool liner. Before beginning the liner installation, be sure to note the orientation of the star thru-wall holes at the 12, 3, 6, and 9 (clock positions) as they will be hidden once the liner is installed. After the liner is installed, add water to the pool to weigh the liner down pulling it tight. When the liner is tight, cut the holes for each thru-wall fitting and threaded rod hole using a sharp utility knife. Cut the holes as small as possible for the threaded rods (Fig 4.13).

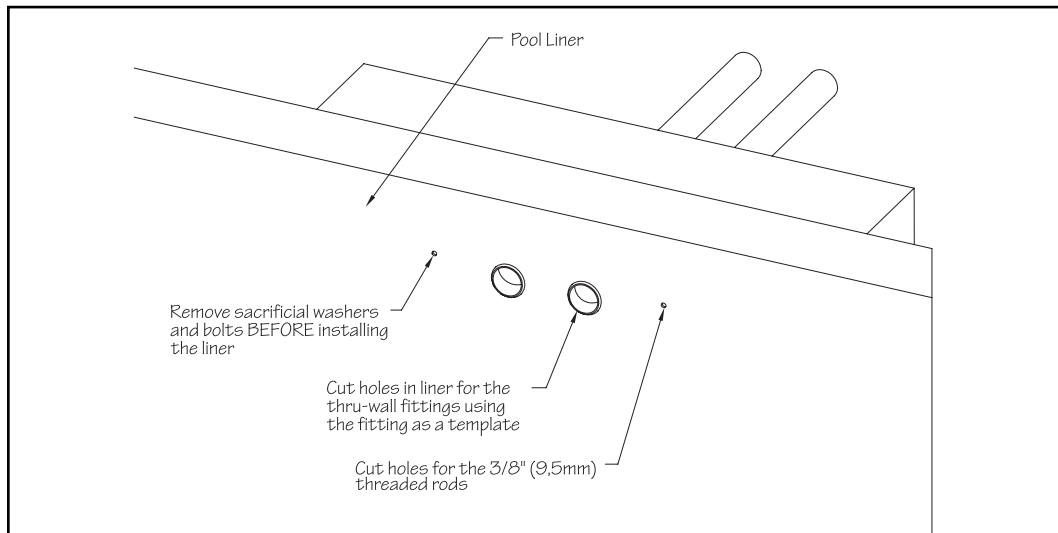

Fig. 4.13

Using a scratch awl, poke the holes out in each star thru-wall fitting (holes located in 12, 3, 6, 9 clock positions) and install the thru-wall faceplates using the screws provided. Tighten the screws with a hand screwdriver to avoid cracking the faceplates. Apply RTV or a similar caulk to the threaded stud and rubber washer and thread each stud into the 3/8" (9,5mm) holes in the liner/pool wall making sure the rubber washer is flush against pool liner. (Fig 4.14).

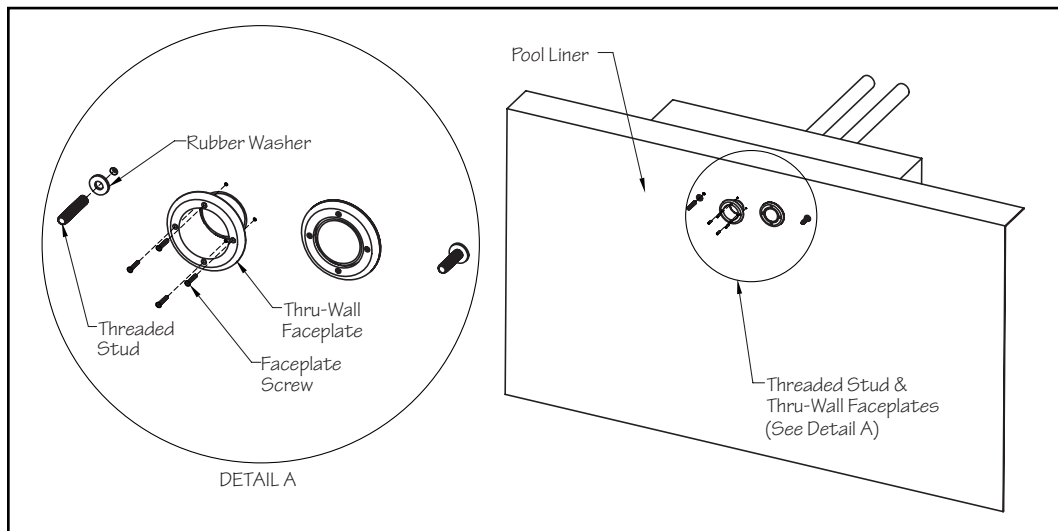

Fig. 4.14

4.C. Gunite Pool with a Vinyl Liner

If the pool being constructed is a gunite pool with a vinyl liner, please follow the instructions below.

The Wall Mount Fastlane Pro Mounting Kit for steel/polymer/gunite pools with a vinyl liner includes the following:

- (1) PVC Wall Bracket
- (2) Bonding Clamp
- (2) 3/8" (9,5mm) Stainless Steel Threaded Mounting Rod
- (2) 3/8" (9,5mm) Stainless Steel Coupler
- (2) 3/8" (9,5mm) Stainless Steel Threaded Stud
- (4) 3/8" (9,5mm) Stainless Steel Jam Nut
- (2) 3/8" (9,5mm) Stainless Steel Flat Washer
- (2) 3/8" (9,5mm) Stainless Steel Lock Washer
- (2) 3/8" (9,5mm) Rubber Washer
- (2) 3/8" (9,5mm) Stainless Steel with Neoprene (Sacrificial Washer)
- (2) 3/8" (9,5mm) Stainless Steel Hex Head Bolt (Sacrificial Bolt)
- (2) 1-1/2" (38mm) Star Thru-Wall Fitting
- (2) 1-1/2" (38mm) MPT x FSlip Adapter
- (2) 1-1/2" (38mm) MPT x 1" (25mm) FPT Bushing Reducer
- (2) 1" (25mm) Liquid Tight Fitting
- (1) Clear Silicone

Install the star thru-wall fittings in the cutouts of the wall mount bracket making sure the holes in the fittings are oriented in the 12, 3, 6, and 9 (clock positions) as shown in Figure 4.15.

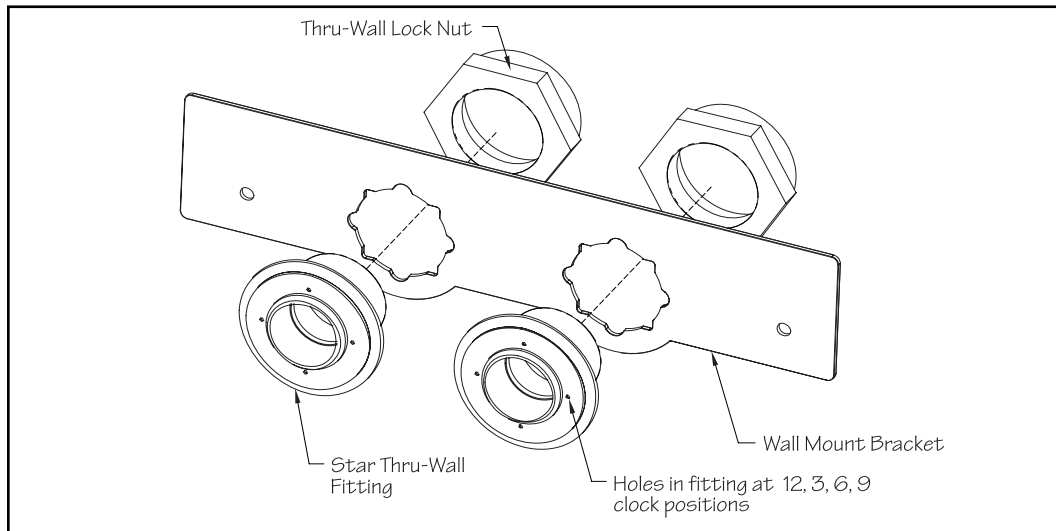

Fig. 4.15

Thread the 3/8" (9,5mm) jam nut onto the threaded rod. Thread the hex coupling onto the threaded rod so that half of the hex coupling is threaded onto the rod and the other half that's facing the pool is protruding off the threaded rod. Tighten the jam nut so that its flush with the hex coupling to prevent the hex coupling from threading further onto the rod (Fig 4.16).

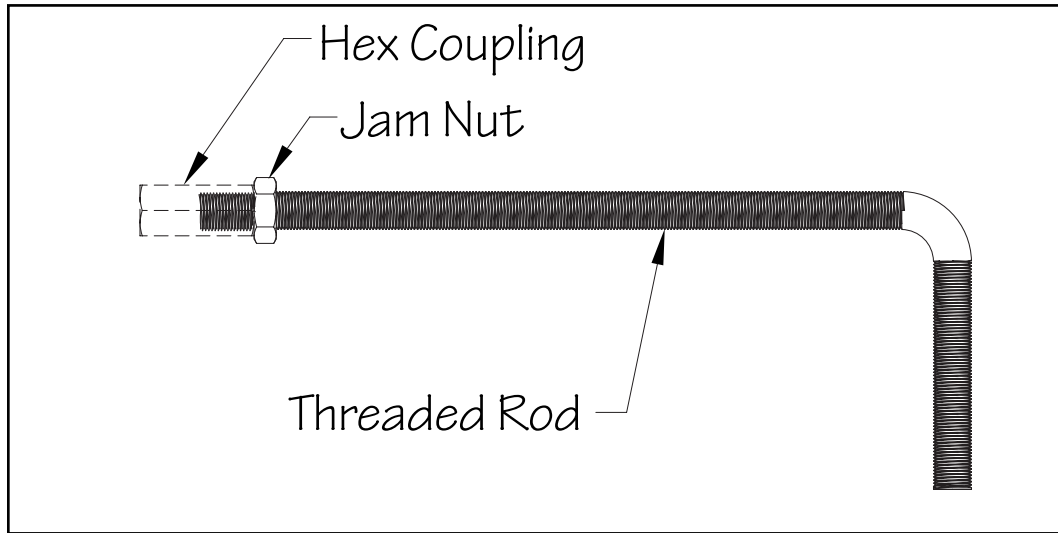

Fig. 4.16

On the backside of the bracket, position each threaded rod with the hex coupling to align with the 3/8" (9,5mm) holes. On the front of the bracket, thread the sacrificial 3/8" (9,5mm) steel with rubber washers and bolts into the hex couplings (Fig 4.17).

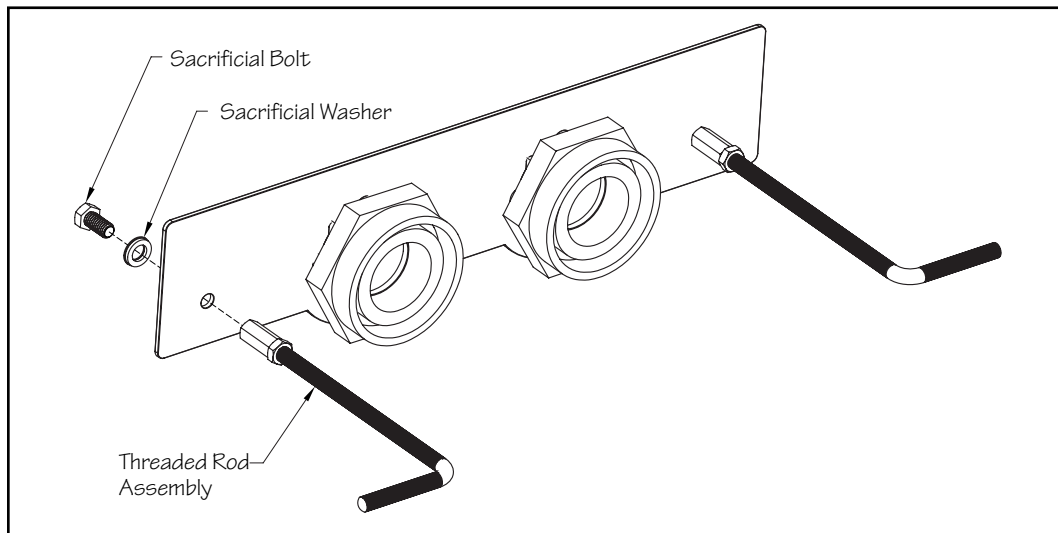

Fig. 4.17

The bracket is to be installed into the pool wall so that the two threaded rods are 1-1/2" (38mm) above the intended waterline, which is typically halfway up the skimmer. The bottom straight edge of the bracket should be aligned with the expected waterline. Level and position the bracket so that the PVC surface of the bracket will be flush with the finished surface of the pool wall. The threaded rods attached to the bracket must be tied back to the rebar of the pool with rebar wire. Once encased in concrete, these rods will serve as a suitable hanger. The threaded rods must penetrate 1-1/4" to 1-1/2" (31,8mm x 38mm) into the finished pool and will be used to hang the Fastlane Pro (Fig 4.18).

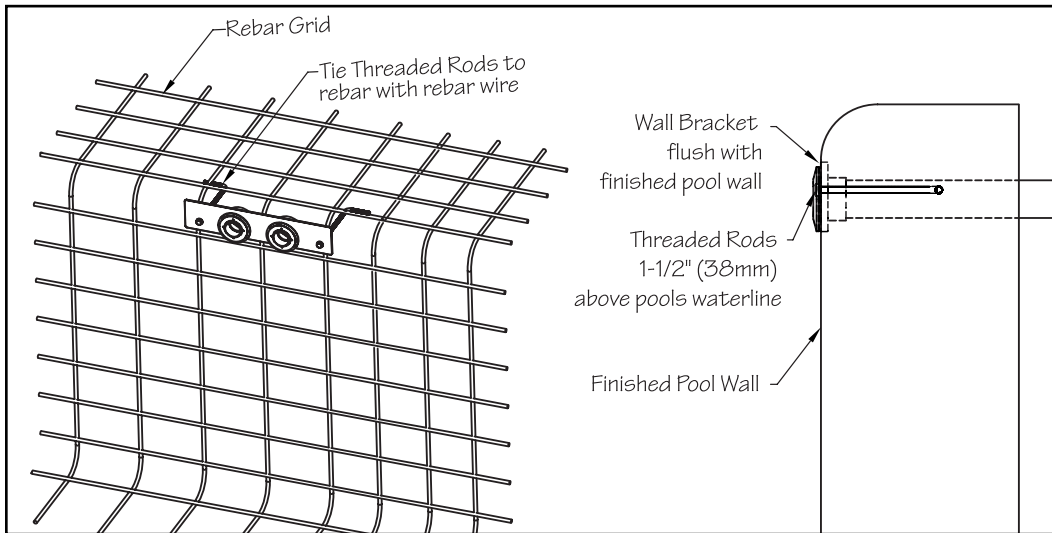

Fig. 4.18

The location of the Hydraulic Power Unit should be determined at this point in the installation. Unroll lengths of 1-1/2" (38mm) flexible PVC pipe from the back of the wall mount bracket to the Power Unit. Any bends in the flexible pipe **MUST** be gradual sweeps and not sharp to allow the hydraulic hoses to easily be fed through each conduit.

If the Hydraulic Power Unit is within 25' (7,6m) of the pool: Each length of flexible pipe should exit the ground within 4' (1,2m) of the Power Unit. Approximately 4' (1,2m) of hydraulic hose is required to make the hydraulic connections at the Power Unit.

If the Hydraulic Power Unit is more than 25' (7,6m) away from pool: 25' (7,6m) of flexible pipe, a junction box, and an additional length of flexible pipe **MUST** be employed. It is at the junction box where a step up to a larger diameter hydraulic hose occurs to reduce pressure loss and a potential reduction in performance. In this case, the length of flexible pipe between the wall mount bracket and junction box **MUST** be 24' 6" (7,5m). This will allow the hydraulic hoses to terminate just inside the junction box. An additional length of flexible pipe coming out of the junction box should exit the ground within 4' (1,2m) of the Power Unit. See Section 5: Junction Box for detailed information.

Apply Teflon thread sealant to the threads of the 1-1/2" (38mm) MPT x FSLIP adapters and thread them into the thru-wall fittings on the backside of the wall mount bracket. Glue the lengths of flexible pipe into the adapters (Fig 4.19).

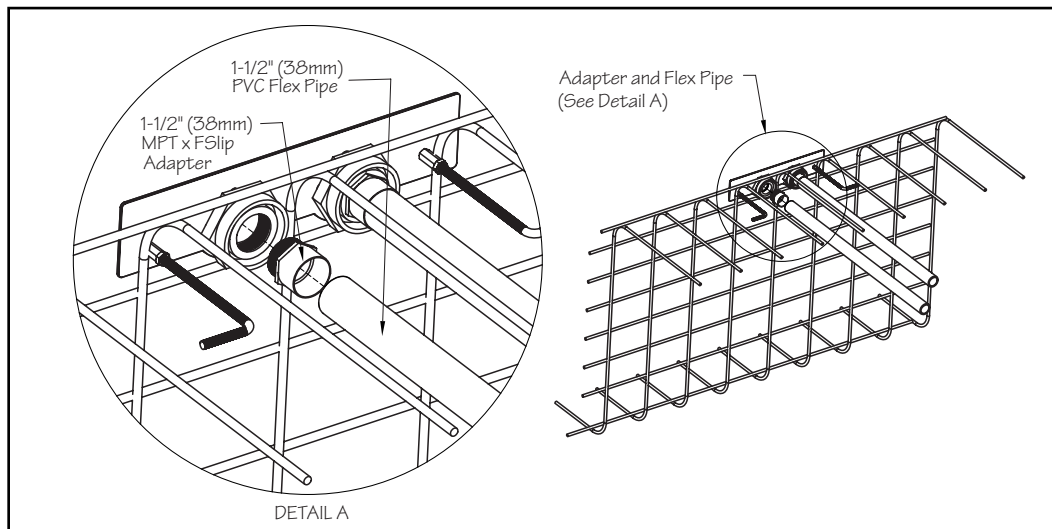

Fig. 4.19

If the distance between the wall mount bracket and the hydraulic power unit is greater than 25ft (7,6m) then a junction box and additional flex pipe must be employed. In this case, the flex pipe between the wall mount bracket and the junction box must be 24ft 6in (7,5m). This will allow the hydraulic hose attached to the Fastlane Pro to terminate just inside the junction box. Refer to section 5 for additional information.

The threaded rods must be tied into the pools bonding grid. Secure a bonding clamp to each threaded rod. Attach a #8 solid copper wire to each bonding clamp. These wires **MUST** be attached to a bonding connection that's incorporated into the pools bonding grid. In most cases this will be a connection at the rebar. Verify ALL bonding connections are tight before shooting gunite (Fig 4.20).

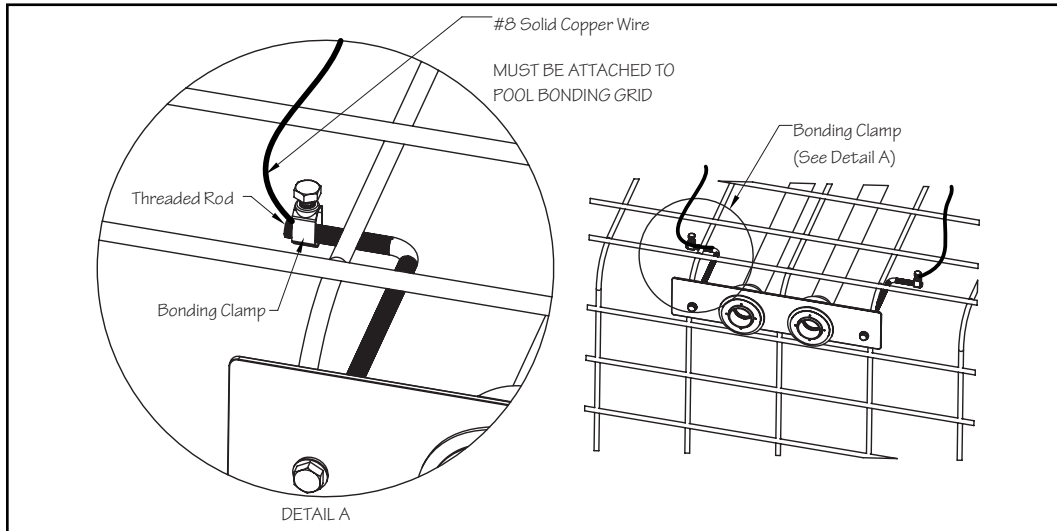

Fig. 4.20

Prior to shooting gunite, it is critical that the opening of each thru-wall and the sacrificial bolt be covered. No gunite can be embedded in these areas.

After verifying the bracket is positioned, bonding connections are secure, and thru-wall openings/sacrificial bolts are covered, gunite can be shot.

After the concrete has cured remove the sacrificial 3/8" (9,5mm) washers and bolts and install the pool liner. Before beginning the liner installation, be sure to note the orientation of the star thru-wall holes at the 12, 3, 6, and 9 (clock positions) as they will be hidden once the liner is installed (Fig 4.21).

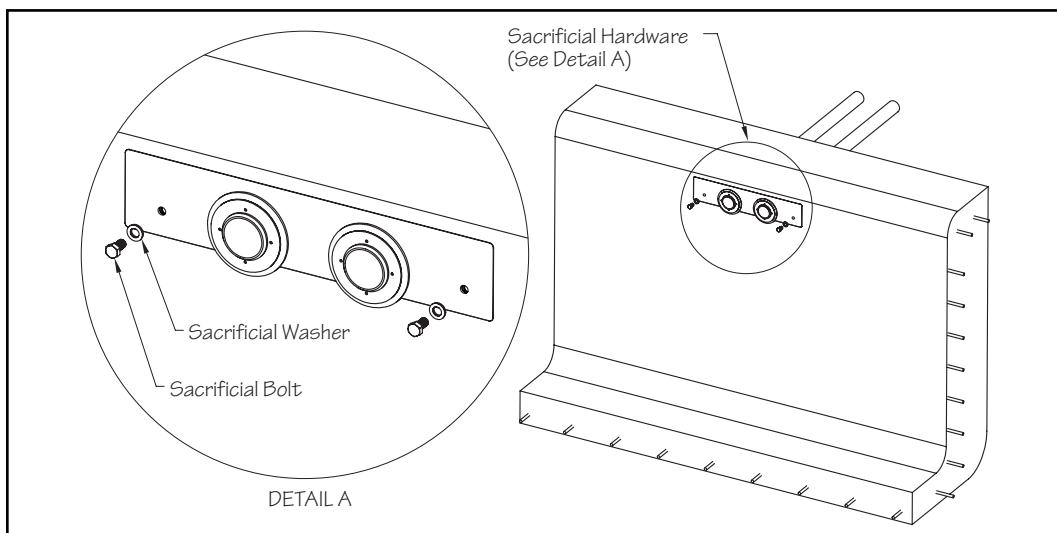

Fig. 4.21

After the liner is installed, add water to the pool to weigh the liner down pulling it tight. When the liner is tight, cut the holes for each thru-wall fitting and threaded rod hole using a sharp utility knife. Cut the holes as small as possible for the threaded rods (Fig 4.22).

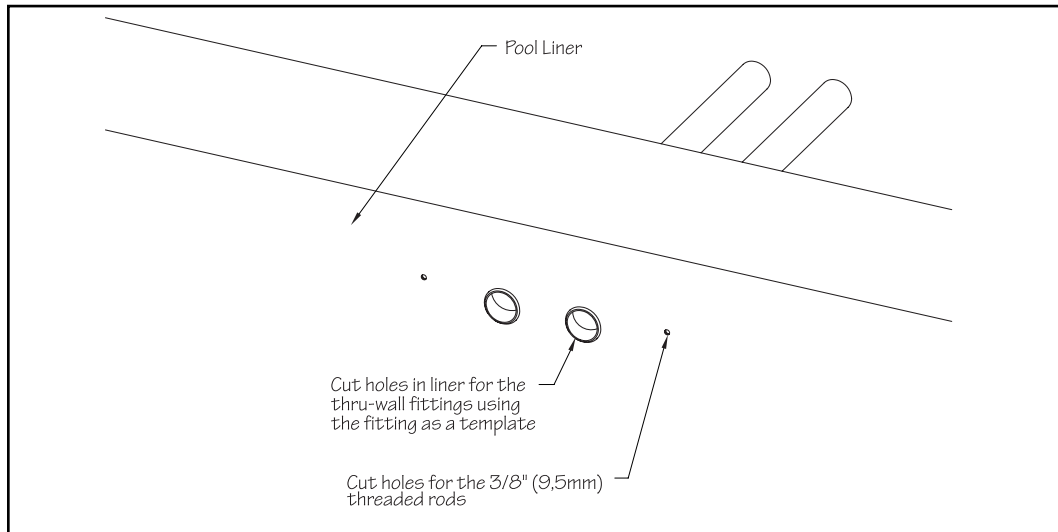

Fig. 4.22

Using a scratch awl, poke the holes out in each star thru-wall fitting (holes located in 12, 3, 6, 9 clock positions) and install the thru-wall faceplates using the screws provided. Tighten the screws with a hand screwdriver to avoid cracking the faceplates. Apply RTV or a similar caulk to the threaded stud and rubber washer and thread each stud into the 3/8" (9,5mm) holes in the liner/pool wall making sure the rubber washer is flush against pool liner (Fig 4.23).

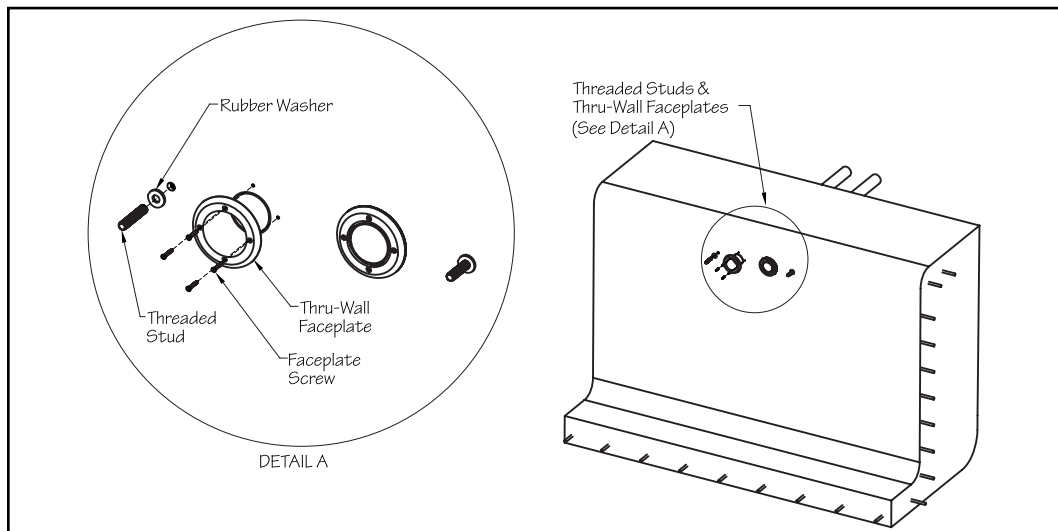

Fig. 4.23

4.D. Fiberglass Pool

If the pool being installed is fiberglass, then follow the instructions below:

The Wall Mount Fastlane Pro Mounting Kit for Fiberglass pools includes the following:

- (1) PVC Wall Bracket
- (2) Bonding Clamp
- (2) 3/8" (9,5mm) Stainless Steel Threaded Mounting Rod
- (6) 3/8" (9,5mm) Stainless Steel Jam Nut
- (6) 3/8" (9,5mm) Stainless Steel Flat Washer
- (2) 3/8" (9,5mm) Stainless Steel Lock Washer
- (2) 1-1/2" (38mm) Thru-Wall Fitting
- (2) 1-1/2" (38mm) MPT x 1" (25mm) FPT Bushing Reducer
- (2) 1" (25mm) Liquid Tight Fitting

Remove the hardware from the PVC bracket. In this application the bracket will serve primarily as a template. Position the bracket on the pool wall where the Fastlane Pro will be placed. Align the etched mark on the bracket with the expected waterline, which is typically halfway up the skimmer opening. The bracket must be level on the pool wall. Temporarily adhere the bracket to the pool wall using duct tape. Trace the outlines of the thru-wall fittings and threaded rod openings on to the pool wall (Fig 4.24).

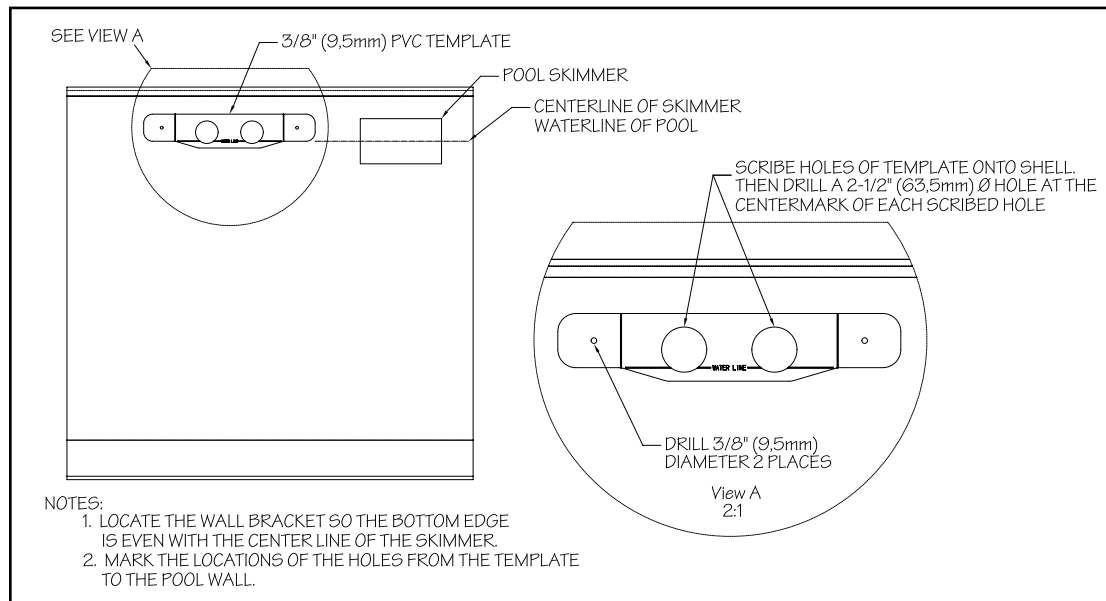

Fig. 4.24

Once the openings are marked, the bracket can be removed from the pool wall. Use a 2-1/2" (63,5mm) hole saw to drill the thru-wall holes. Use a 3/8" (9,5mm) drill bit for the threaded rod holes.

Cut the center portion out of the bracket using the etched marks in the brackets as a guide. The two end portions will be used as washers on the backside of the pool wall (Fig 4.25).

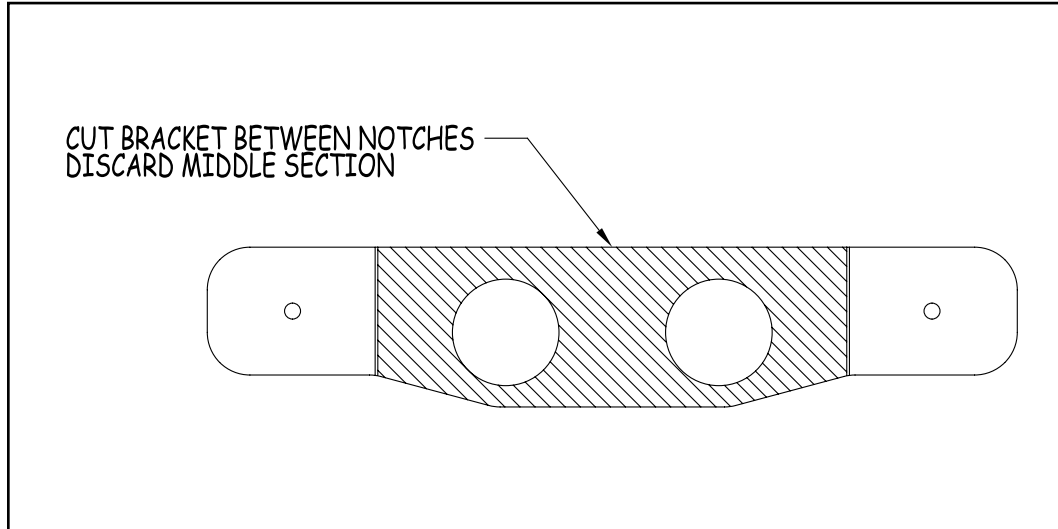

Fig. 4.25

Insert the threaded rod into each PVC washer making sure there is a flat washer and jam nut on the backside of the PVC washer (Fig 4.26 DETAIL A). Position and install each PVC washer and threaded rod assembly against the backside of the pool wall. Adjust the hardware on the threaded rods so that they extend approximately 1-1/2" (38mm) into the pool. Install an additional flat washer and jam nut onto each threaded rod on the inside of the pool (Fig 4.26 DETAIL B).

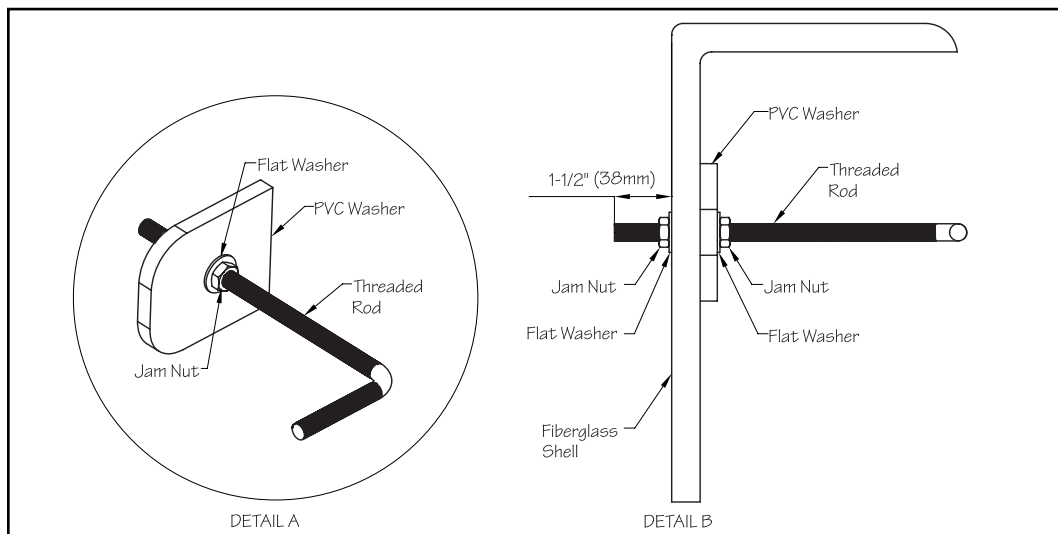

Fig. 4.26

The backside of the thru-wall holes may need to be sanded flat so that a proper seal can be made. Place one of the rubber gaskets onto each thru-wall fitting. The second rubber gasket will not be used in this application. Insert the thru-wall fittings into the cut outs and place the cork gaskets onto the fittings on the backside of the pool wall. Thread the lock nuts onto the fittings. The lock nuts should be tightened with a pair of channel locks or strap wrench (Fig 4.27).

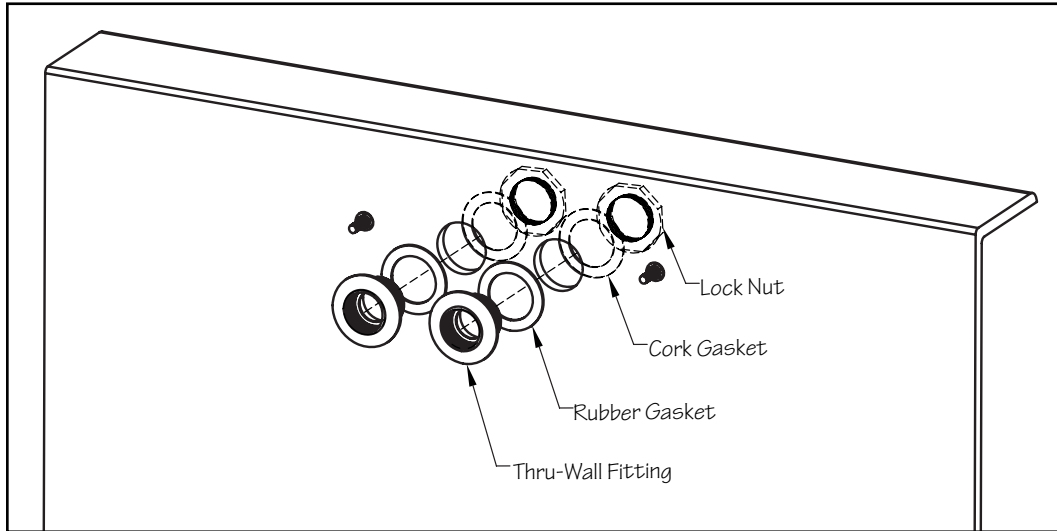

Fig. 4.27

The location of the Hydraulic Power Unit should be determined at this point in the installation. Unroll lengths of 1-1/2" (38mm) flexible PVC pipe from the back of the wall mount bracket to the Power Unit. Any bends in the flexible pipe **MUST** be gradual sweeps and not sharp to allow the hydraulic hoses to easily be fed through each conduit.

If the Hydraulic Power Unit is within 25' (7,6m) of the pool: Each length of flexible pipe should exit the ground within 4' (1,2m) of the Power Unit. Approximately 4' (1,2m) of hydraulic hose is required to make the hydraulic connections at the Power Unit.

If the Hydraulic Power Unit is more than 25' (7,6m) away from pool: 25' (7,6m) of flexible pipe, a junction box, and an additional length of flexible pipe **MUST** be employed. It is at the junction box where a step up to a larger diameter hydraulic hose occurs to reduce pressure loss and a potential reduction in performance. In this case, the length of flexible pipe between the wall mount bracket and junction box **MUST** be 24' 6" (7,5m). This will allow the hydraulic hoses to terminate just inside the junction box. An additional length of flexible pipe coming out of the junction box should exit the ground within 4' (1,2m) of the Power Unit. See Section 5: Junction Box for detailed information.

Glue the lengths of flexible pipe into the thru-wall fittings on the backside of the wall mount bracket (Fig 4.28).

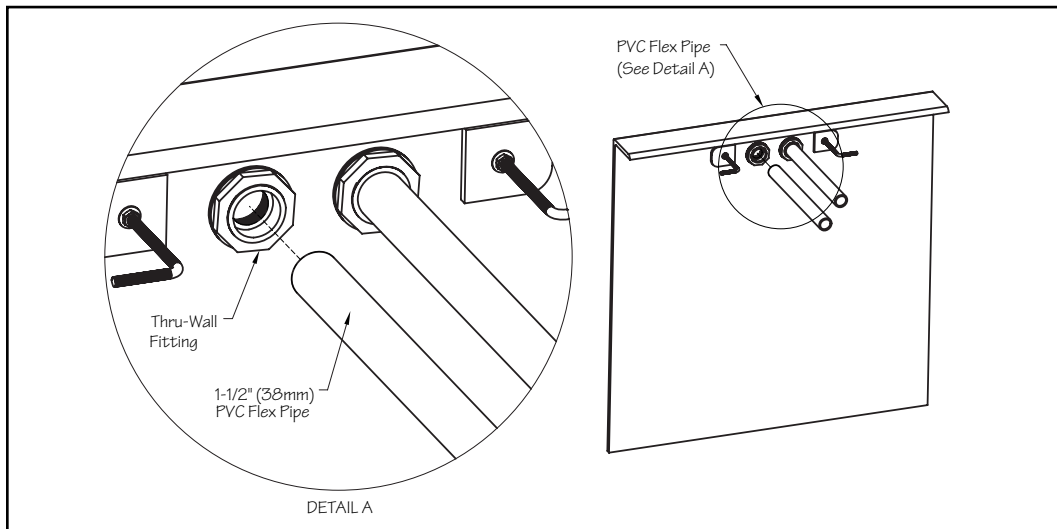

Fig. 4.28

The threaded rods must be tied into the pools bonding grid. If using rebar in the pools concrete collar, tie the threaded rods to the rebar using rebar wire. Secure a bonding clamp to each threaded rod. Attach a #8 solid copper wire to each bonding clamp. These wires **MUST** be attached to a bonding connection that's incorporated into the pools bonding grid. In most cases this connection will be at the pools existing equipment (heater, pump, etc.) that's presumably already tied into the bonding grid of the pool. Verify these connections are tight before pouring concrete (Fig 4.29).

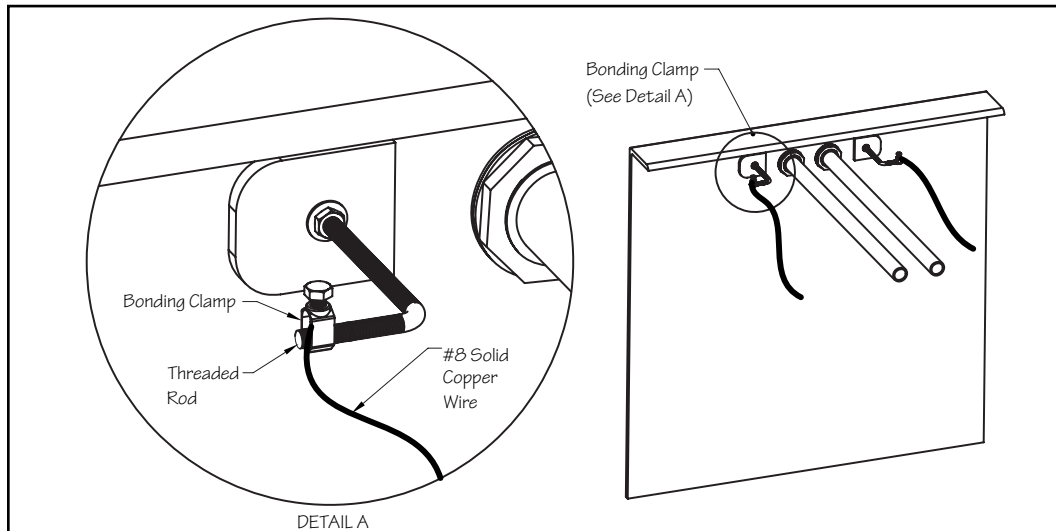

Fig. 4.29

Prior to pouring concrete, it is critical that the opening of each thru-wall and the threaded rods that extend into the finished pool be covered. No concrete can be embedded in these areas.

When all of the connections on the outside of the pool are complete, a concrete collar should be poured around the threaded rods and conduit. This encasement will help secure the Fastlane Pro (Fig 4.30)

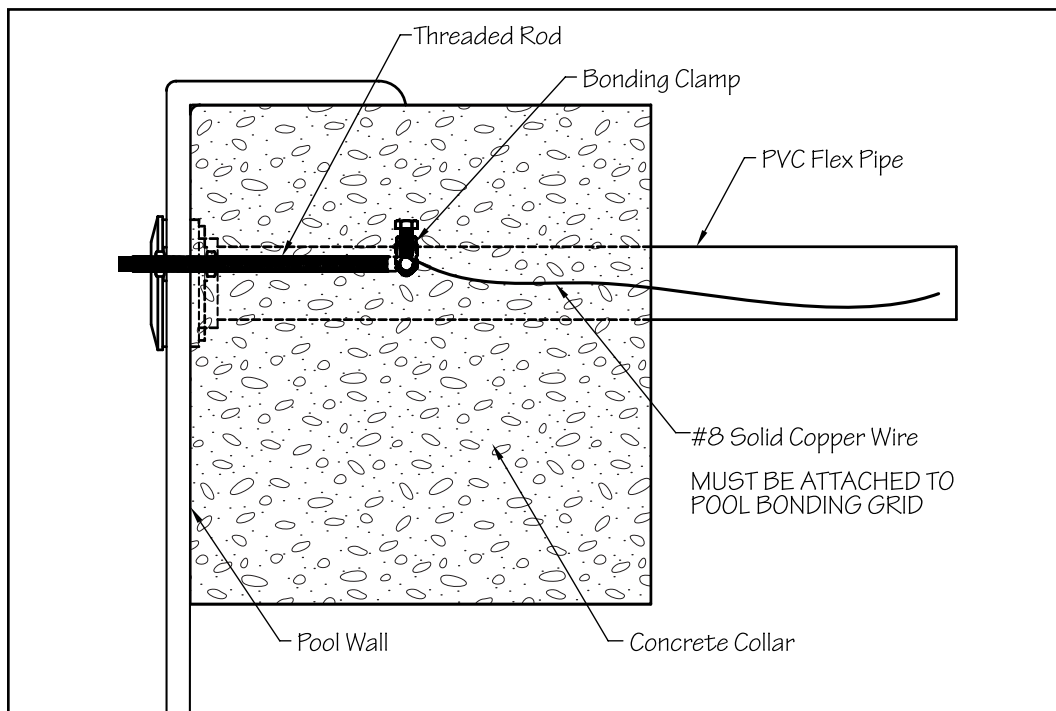

Fig. 4.30

Section 5

JUNCTION BOX AND 1/2" RUN HOSES (OPTIONAL)

The wall mount bracket must be attached on the pool wall as explained in the installation instructions in Section 4. Attached to this bracket are two (2) lengths of 1-1/2" (38mm) PVC flex pipe that run back under the deck and carry two (2) hydraulic hoses.

If the hydraulic hose runs back to the Power Unit are less than 25' (7,6m), it is not necessary to step up to 1/2" run hose to reduce pressure loss. Instead, the 3/8" (9,5mm) hydraulic hose can run directly to the Power Unit in the protective conduit.

If the hydraulic hose runs are greater than 25' (7,6m), in order to reduce pressure loss and potential reduction in speed, a junction box must be used. It is at the junction box where a step up to 1/2" run hose occurs. The hydraulic hose from the Fastlane Pro Swim Unit to the junction box is 3/8" (9,5mm) and the run hose from the junction box to the Power Unit is 1/2". It's important the junction box is installed in suitable location. Access to the junction box **MUST** be maintained for future maintenance.

Junction Box Kit (optional) includes:

(1) Junction Box

(4) 1-1/2" (38mm) FSlip x 1-1/2" (38mm) MPT Adapters

(4) 1-1/2" (38mm) Conduit Locknuts

(1) Roll of Anti-Corrosion Tape

- The 1-1/2" (38mm) PVC flex pipe will need to be cut to 24' 6" (7,5mm) from the wall mount bracket to the junction box.
- Glue the 1-1/2" (38mm) FSlip x MPT Adapter fittings on the end of the PVC flex pipe that will connect to the junction box. Secure the fittings to the junction box with the provided lock nuts.
- To get from the junction box to the Power Unit, run 1-1/2" (38mm) PVC flex pipe.
- Unroll the two (2) lengths of PVC flex pipe from the junction box to the Power Unit. The PVC flex pipe should exit the ground next to the Power Unit.
- Measure the length of PVC flex pipe. Your 1/2" (12,7mm) run hoses will need to be **AT LEAST** 4 feet longer than the length of the PVC flex pipe. Order your 1/2" (12,7mm) run hoses at this time by calling our Customer Service Department at 800-910-2714.
- Adapters to connect the 1/2" (12,7mm) run hoses to the 3/8" (9,5mm) hoses attached to the Fastlane Pro have been provided. They can be found in the 1/2" (12,7mm) run hose box and will be attached at a later step (see section 7).
- If desired, the junction box can be anchored by attaching the feet included with the kit.

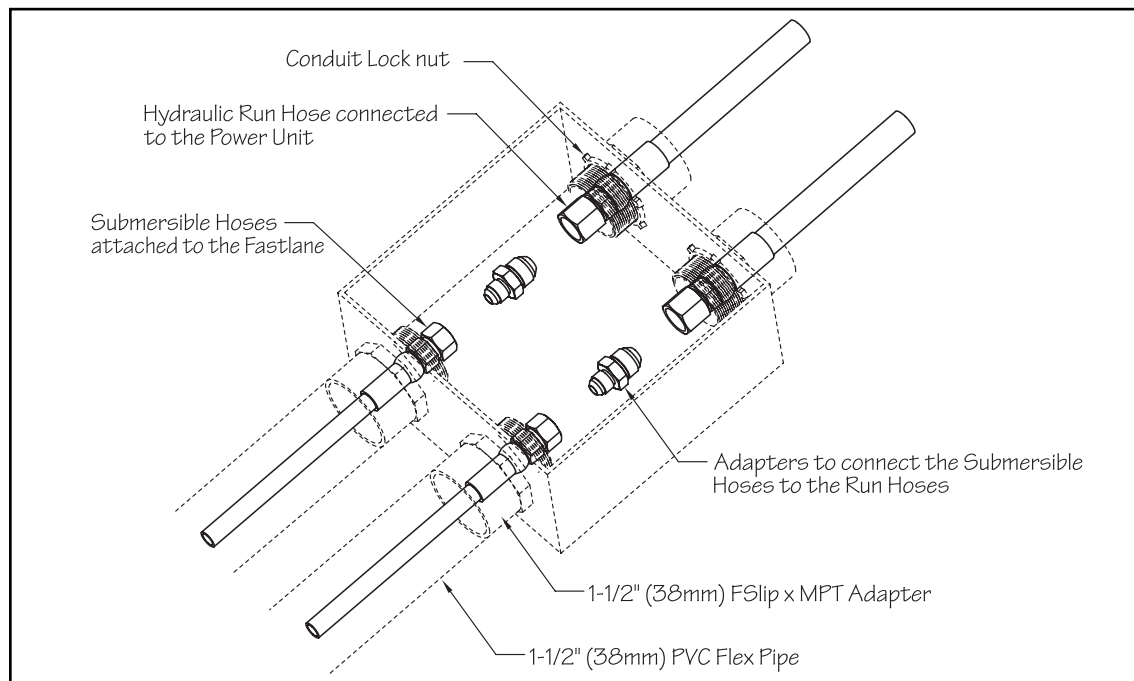

Fig. 5

Section 6

ASSEMBLY OF THE FASTLANE PRO SWIM UNIT

- 6.1 Carefully unpack the swim unit from its boxes. Make sure to remove any hardware packs from the boxes as well. The packaging can be collapsed and used as a protective surface upon which to assemble the Fastlane Pro. The foam packing material can be used to wedge under the base to prevent it from tipping over. When assembling the Fastlane Pro, a low torque setting should be used on the drill to prevent the holes in the acrylic from stripping.
- 6.2 Take care when handling or working with any of the stainless steel components of the swim unit. The ends can be sharp. The first step is to remove the two circular end caps from each side of the cylindrical base. There are 3 arced cover strips around the perimeter of the end cap. Unthread the nine screws that secure the cover strips (3 screws per cover strip). There will be a stainless steel wire connecting the end cap to the base. The wire can be disconnected to make assembly of the unit easier. If disconnected, the wire must be re-attached when assembled. Repeat this step for the other side of the stainless steel base. Carefully set each end cap aside (Fig 6.1).

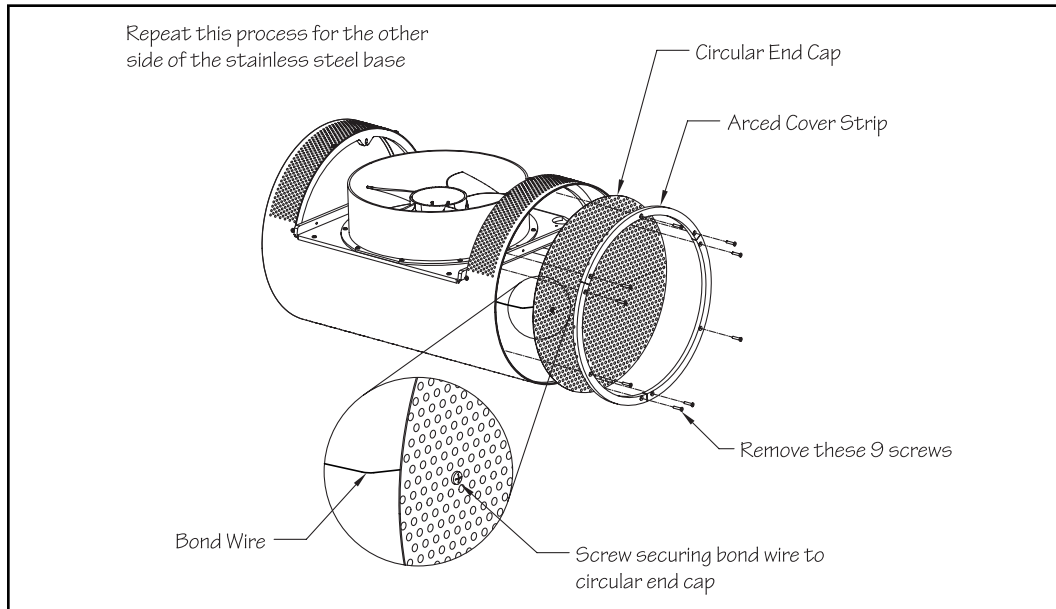

Fig. 6.1

- 6.3 Uncoil the two lengths of hydraulic hose that are attached to the cylindrical base (Fig 6.2).

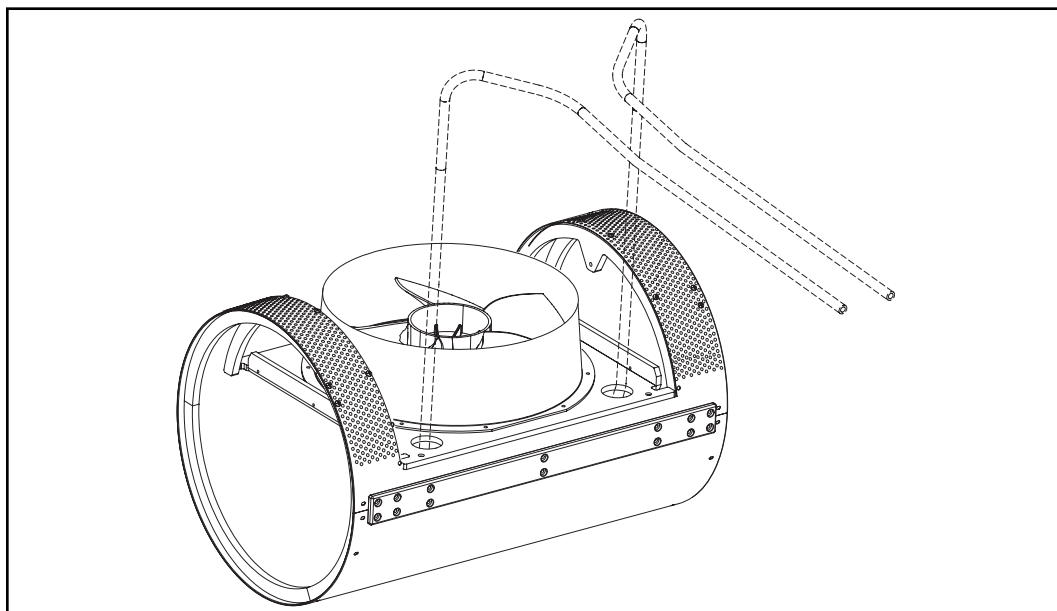

Fig. 6.2

6.4 Remove the throat from the upper housing. There are two screws on each side of the throat. Pull the throat off of the housing and set it aside. Pull the vertical water-conditioning grill up and out of the housing. Pull the horizontal grill out of its track and remove from the housing. Make sure to remove and discard the wood 2x4 spacer from the bottom of the housing before proceeding (Fig 6.3).

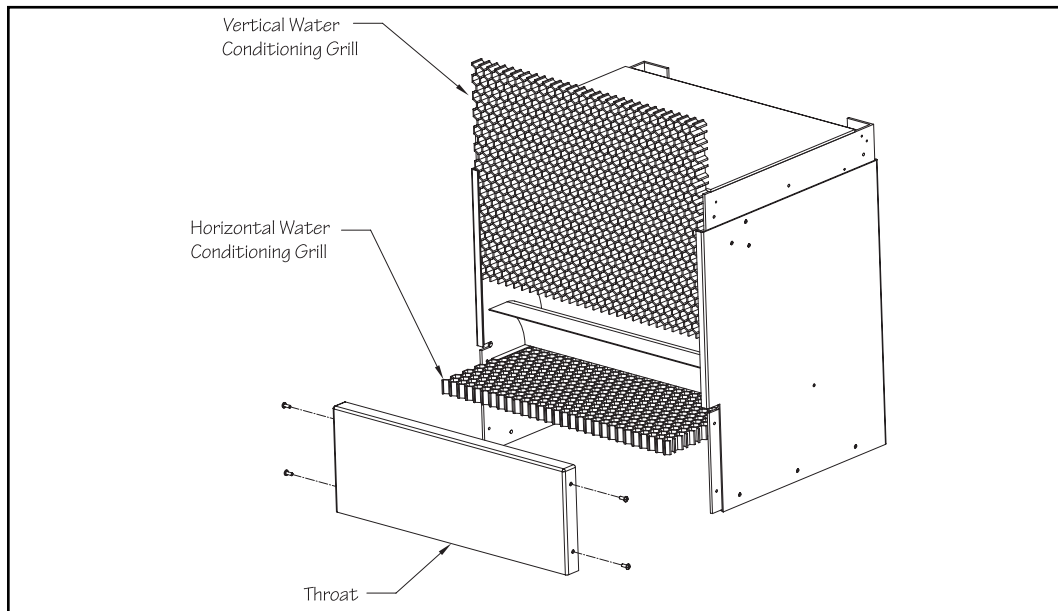

Fig. 6.3

6.5 Carefully remove the protective film encasing the upper housing. Place the upper housing into the opening of the cylindrical base (Fig 6.4A). The hydraulic hoses connected to the base should be aligned with the back of the upper housing. Make sure that the stainless steel bonding wire attached to the motor mount is positioned inside of the upper housing.

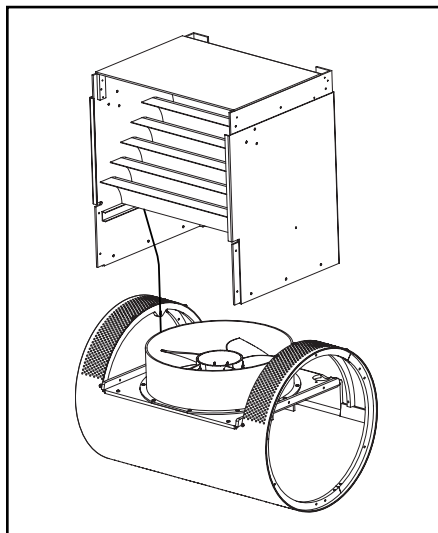

Fig. 6.4A

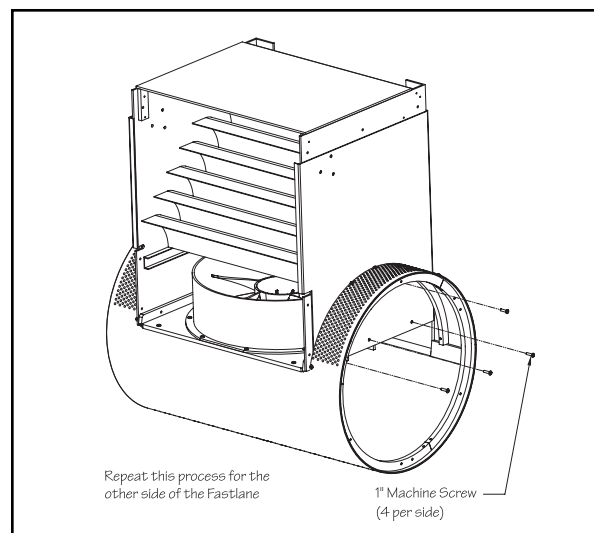

Fig. 6.4B

6.6 Use the provided stainless steel screws to attach the upper housing to the base. There will be 4 screws per side (total of 8). On each side of the housing, there will be 3 screws securing the upper housing to PVC motor mount support and 1 screw attaching the stainless steel reinforcing support to the housing just above the 3 previous screws (Fig 6.4B).

6.7 Carefully lay the Fastlane Pro onto its face. Position the hydraulic hoses up the back of the upper housing. The two hat sections will be placed over the hydraulic hoses. Make sure that the mounting hole in the end of the hat section is facing up. Use the provided 1" (25mm) stainless steel screws to attach the hat sections to the back of the upper housing. There will be 8 screws per hat section (Fig 6.5).

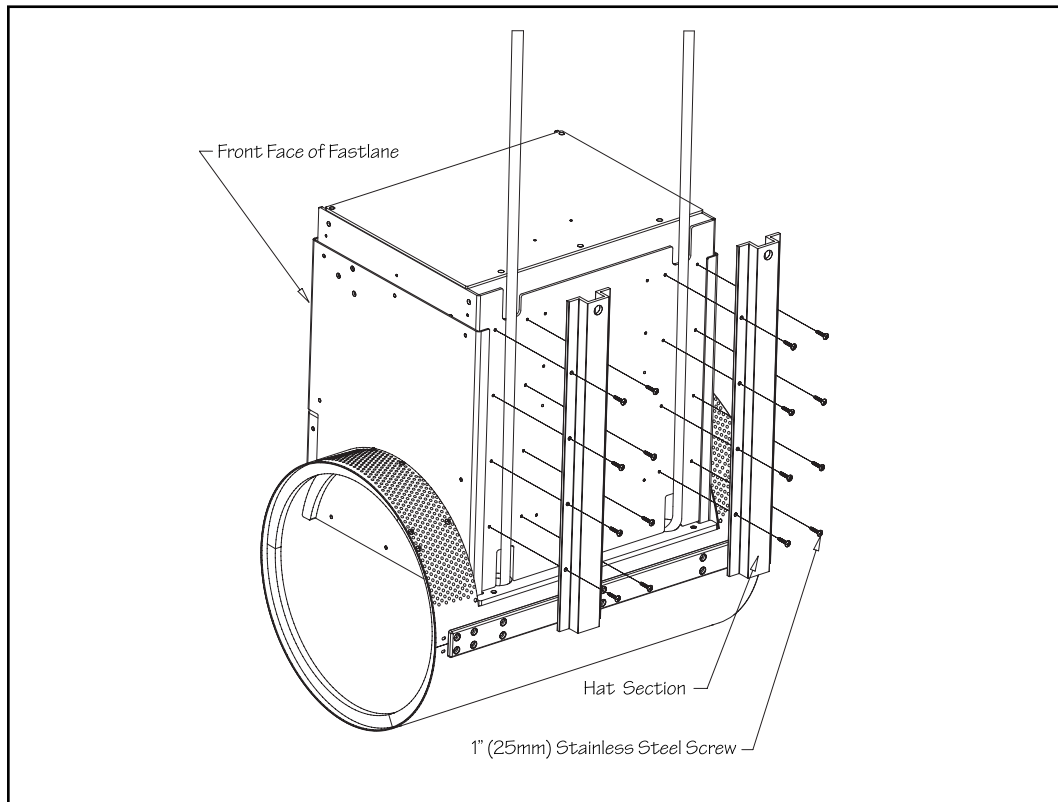

Fig. 6.5

6.8 Pull any excess hose out of the hat channel.

6.8a) If the hydraulic hoses are to be run up and over the pool deck, then proceed to step 6.9 (Fig 6.6A).

6.8b) If the hydraulic hoses are to go through the pool wall, attach the two hoses to the top of the upper housing. There are 2 green hose clamps attached to the top of the housing. The screws that are securing the clamps to the housing will have to be removed in order to secure the hoses to the clamps (Fig 6.6B).

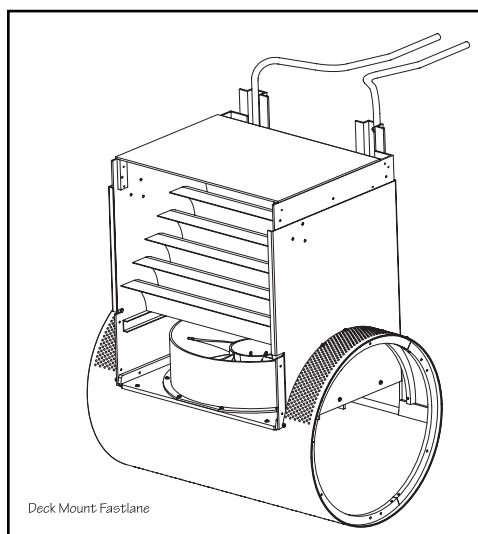

Fig. 6.6A

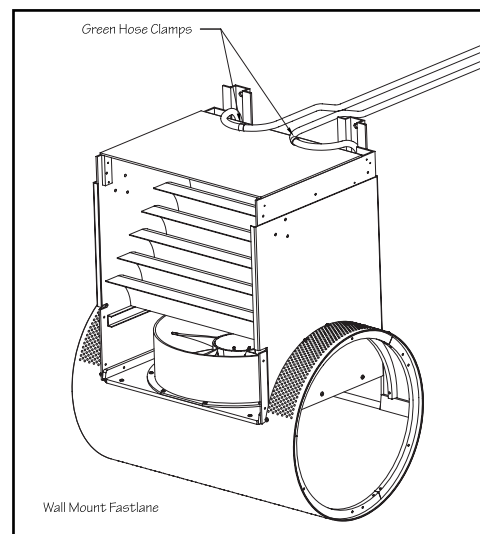

Fig. 6.6B

6.9 Slide the horizontal water-conditioning grill back into its track inside the housing. The horizontal grill is the wider of the two grills (Fig 6.7).

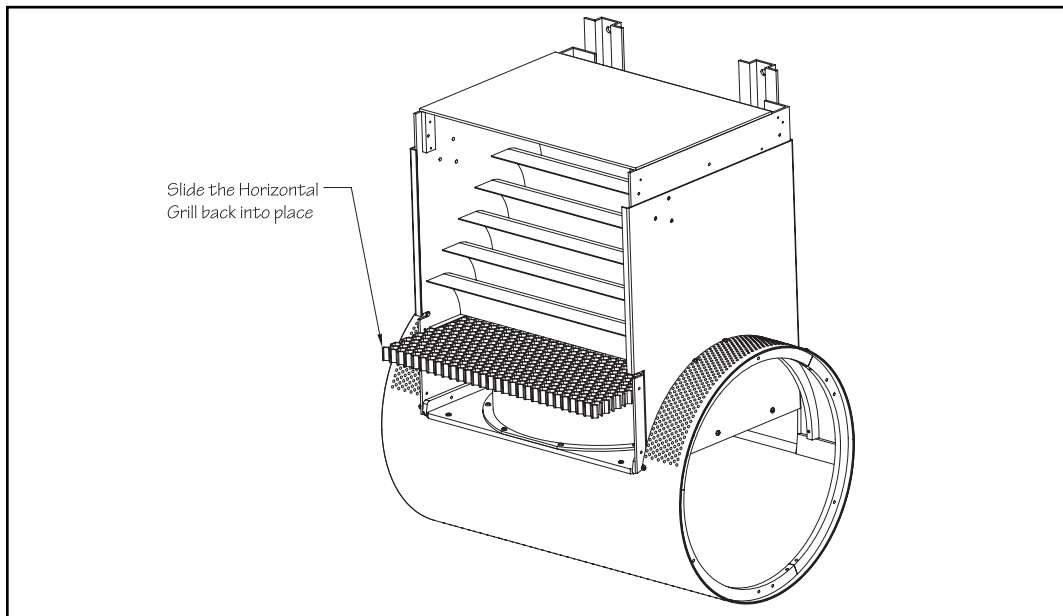

Fig. 6.7

6.10 Install the stainless steel grab bar to the upper housing using the provided stainless steel screws and lock nuts. Feed the stainless steel wire attached to the motor up through the horizontal grill. Then feed the wire up between two of the turning vanes. Place the stainless steel wire (from the motor mount in the base) around the bottom screw on the left side before tightening down on the nut. Place the second stainless steel wire (that exits the top rear of the upper housing) around another screw under one of the grab bar mounting screws (Fig 6.8). **The sacrificial anode should ONLY be used in pools equipped with a salt-chlorine generator for sanitation.**

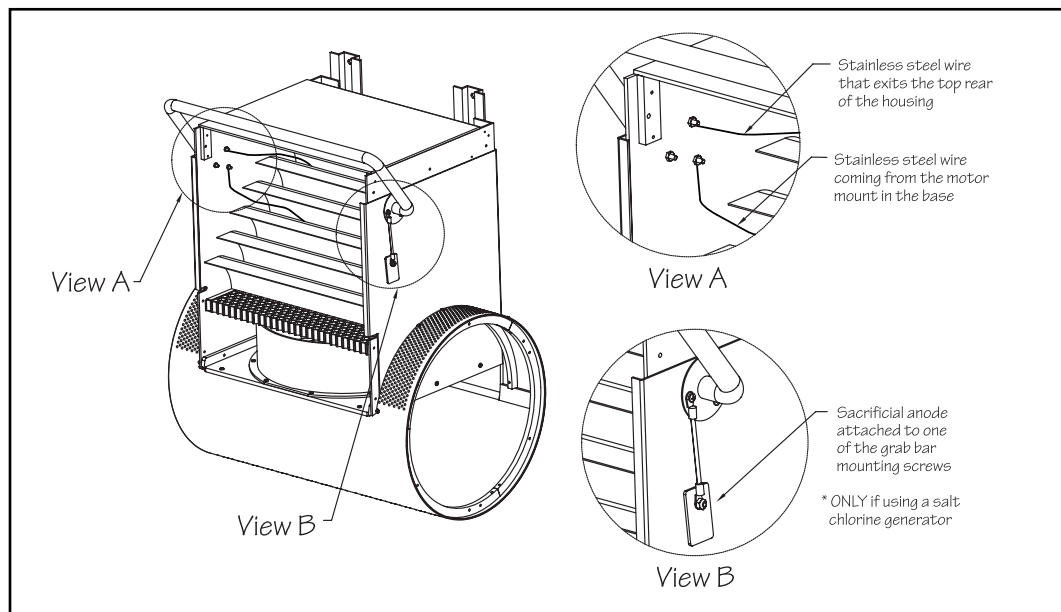

Fig. 6.8

6.11 Reattach the throat to the upper housing. Again, there will be 2 screws on either side of the throat (Fig 6.9).

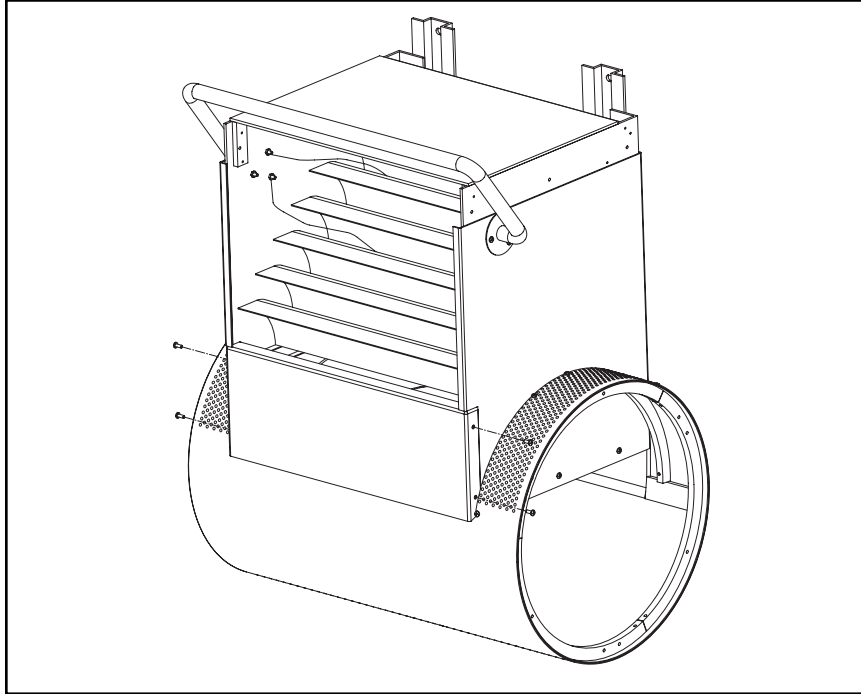

Fig. 6.9

6.12 Slide the vertical water-conditioning grill back down into the housing (Fig 6.10).

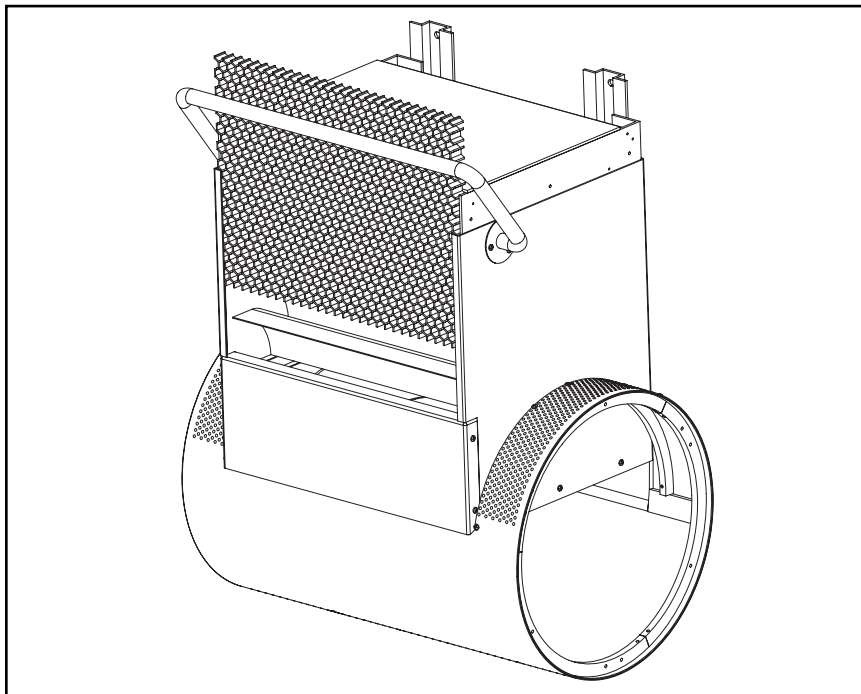

Fig. 6.10

6.13 Re-install the circular end caps. Make sure that the “smooth” surface of the end caps are facing out. If the stainless steel wire from the base to the end cap was removed, then it must be reattached at this time. Align the end caps to the internal PVC supports so that the holes in the internal supports are aligned with holes in the end caps. Position the arced cover strips over the end caps, making sure to align the hole in the arced cover strips with the holes in the stainless end caps and the internal PVC supports. Install the nine screws (3 per cover strip) that were removed in step 6.1. Repeat for the remaining end cap (Fig 6.11).

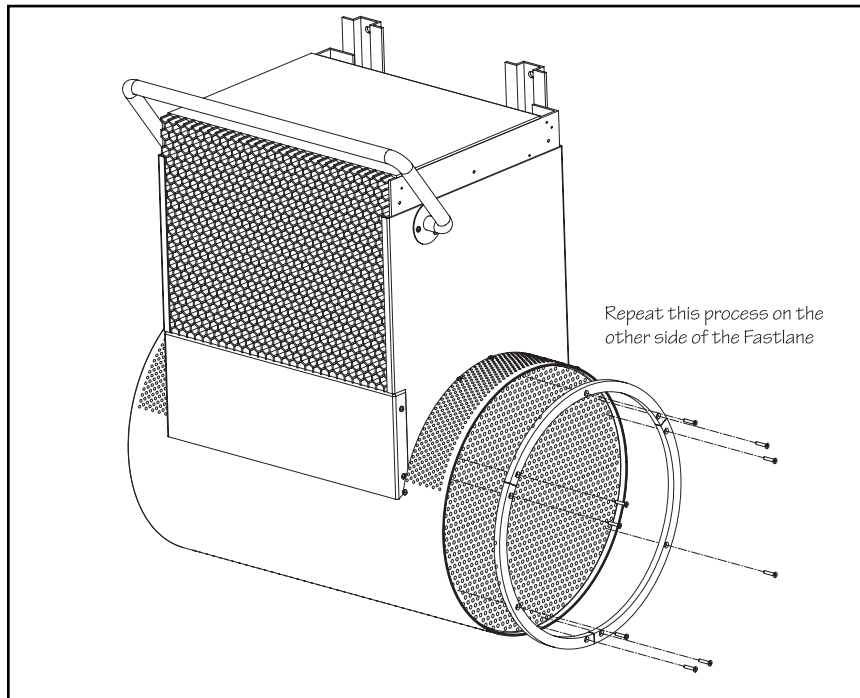

Fig. 6.11

6.14 Once the Fastlane Pro is installed in the pool, place the housing lid onto the housing and use the provided screws to attach. There will be three screws per side, for a total of six (Fig 6.12).

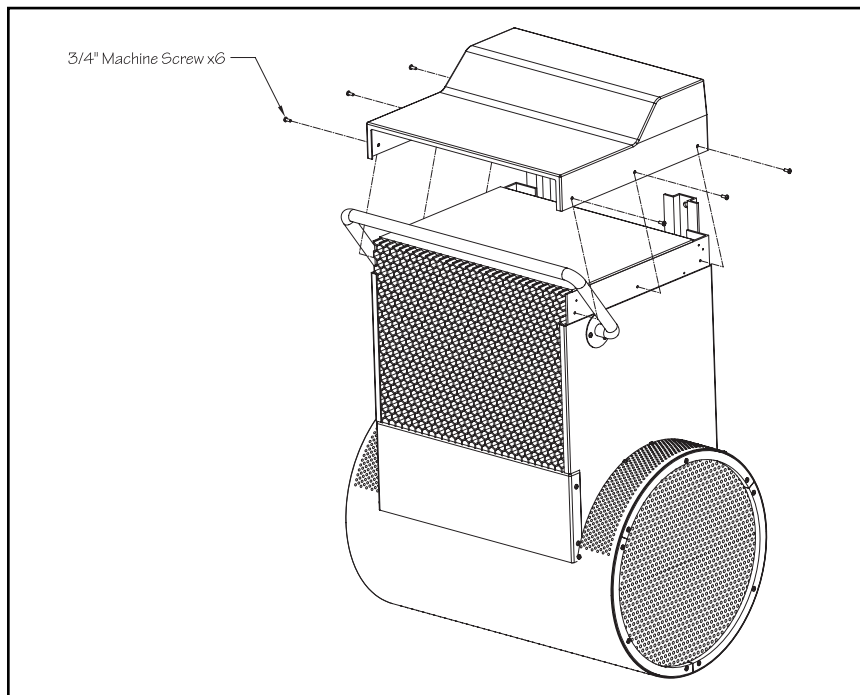

Fig. 6.12

Section 7

INSTALLATION OF YOUR WALL MOUNT FASTLANE PRO

Fill the pool up to operating level, which should be approximately 1-1/2" (38mm) below the mounting rods.

Apply Teflon sealant to the threads of each 1-1/2" (38mm) MPT x 1" (25mm) FPT bushing reducer and thread them into the thru-wall fittings. Then apply Teflon thread sealant to the threads of the liquid tight fittings and thread them into the bushing reducers (Fig 7.1).

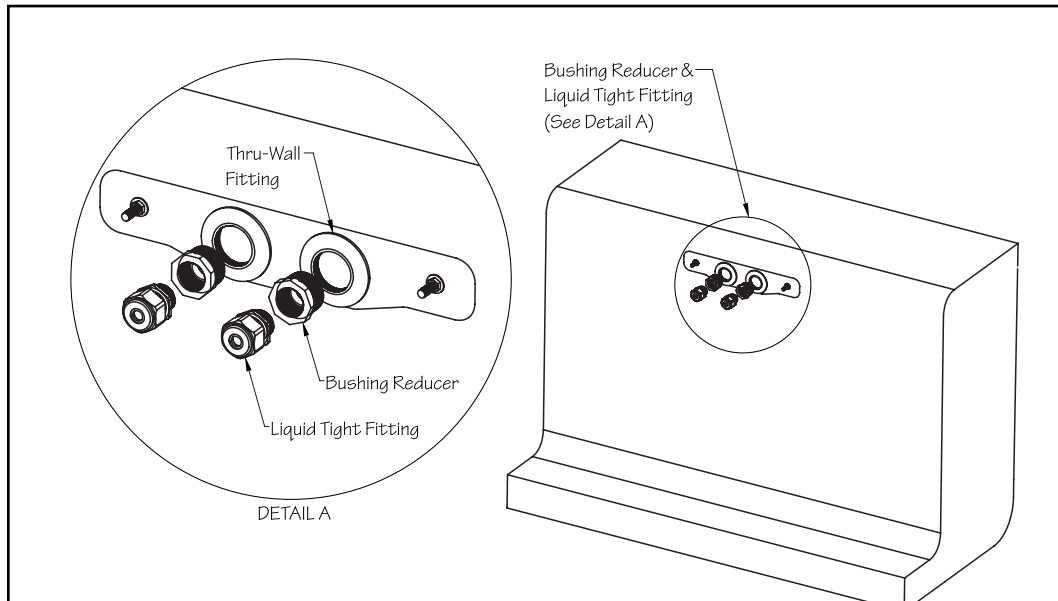

Fig. 7.1

Using two people, carefully lower the Fastlane Pro into the pool. Align the holes at the top of the protective hat sections with the threaded mounting rods and rest the Fastlane Pro into place. The Fastlane Pro will hang from the mounting rods. Place a 3/8" (9,5mm) flat washer onto each mounting rod making sure it's flush against the hat channel. **Secure the stainless steel bond wire that exits the top of the Fastlane Pro to the threaded rod.** Place a 3/8" (9,5mm) lock washer and jam nut onto each threaded rod to secure the Fastlane Pro (Fig 7.2).

Insert the hoses into the conduits. The hoses should cross over themselves prior to inserting into the conduit (i.e. left hose will be inserted into the right conduit)

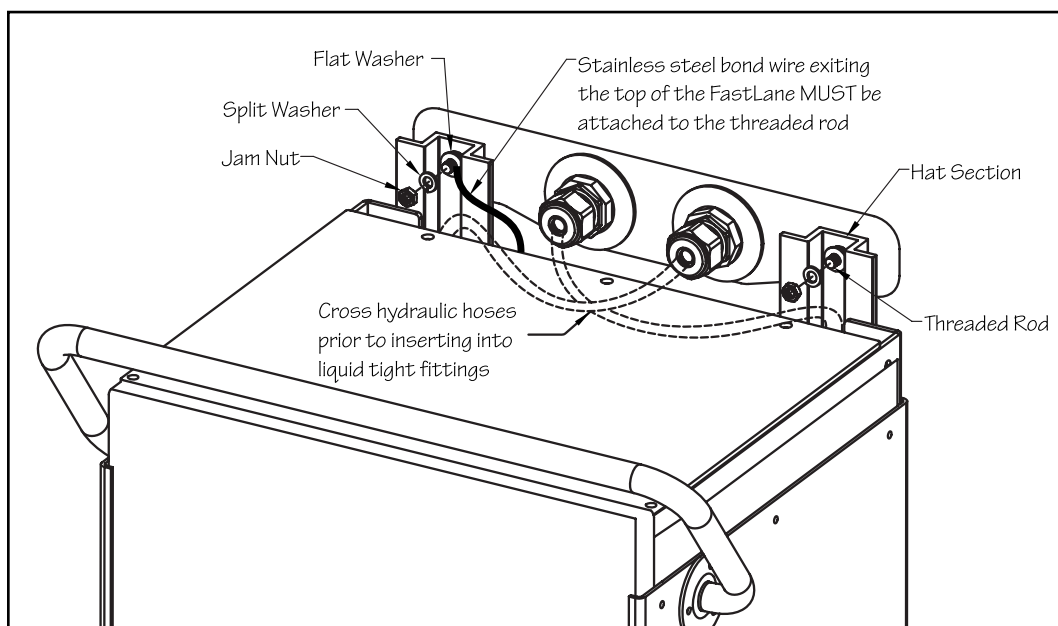

Fig. 7.2

Section 8

DECK MOUNT FASTLANE PRO HOSE COVER TRAY INSTALLATION

- 8.1 Choose where the Fastlane Pro is to be placed in the pool. The water depth must be 39" (99cm). There must be a minimum of 24" (61cm) between the Fastlane Pro and any adjacent wall or pool obstruction.
- 8.2 Position the hose cover tray onto the pool deck so that the vertical lip of the tray is seated firmly against the coping. The coping MUST fully support the hose cover tray. The tray will be centered to the Fastlane Pro. If the pool has bullnose coping it is acceptable for the hose cover tray to be slightly out of level as shown in Figure 8.1.

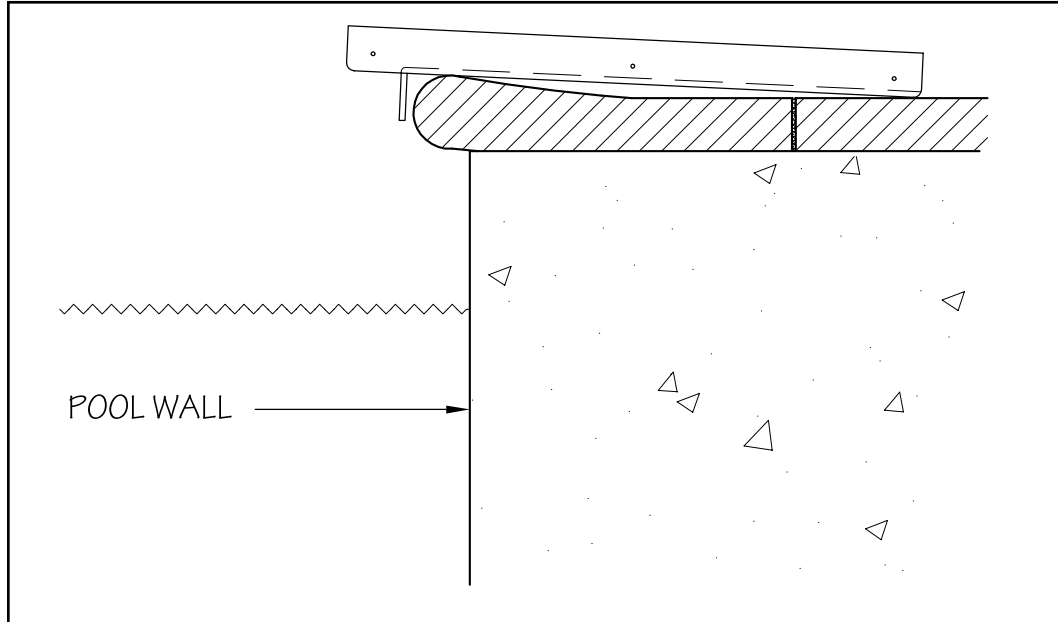

Fig. 8.1

- 8.3 Use the provided 5/32" (4mm) drill bit to drill a hole into the deck approximately 2" (50,8mm) deep through the two holes in the rear of the tray. These holes must be drilled into solid decking material. While these 2 screws are enough to secure the Fastlane Pro to the pool wall, extra anchor screws have been provided for additional anchor points if desired (Fig 8.2).

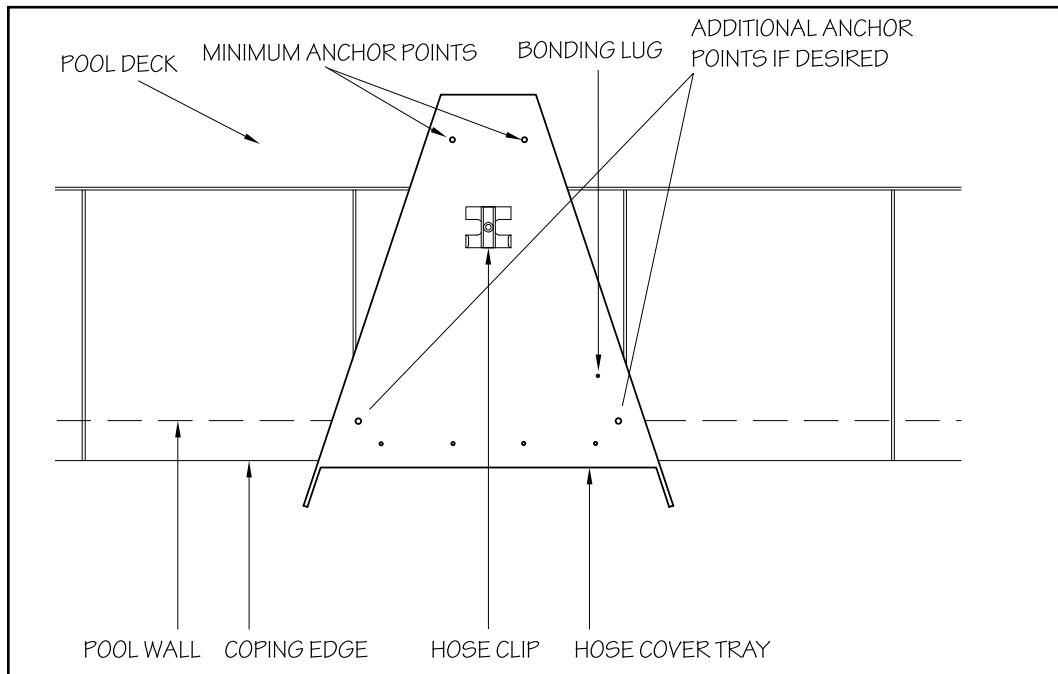

Fig. 8.2

Section 9

DECK MOUNT FASTLANE PRO INSTALLATION

9.1 Loosely secure the hanger bracket to the hose cover tray with one of the provided 1/2" (12,7mm) stainless steel screws. Measure down from the top of the hanger bracket to the water line (this measurement is called freeboard). Once the measurement has been taken, remove the hanger bracket from the tray (Fig 9.1).

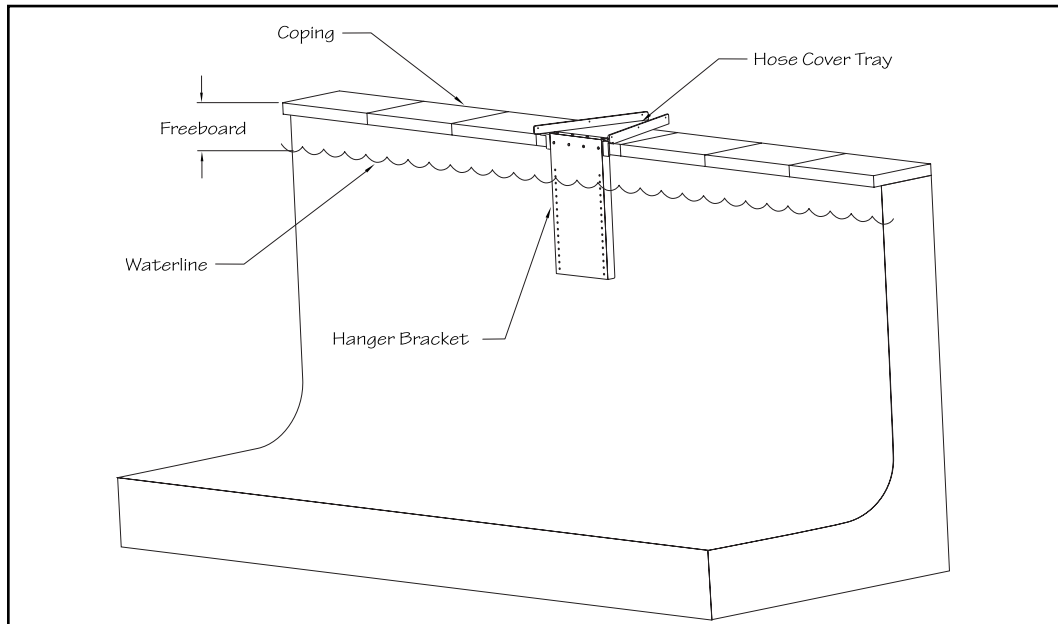

Fig. 9.1

9.2 Carefully lay the assembled Fastlane Pro down on its front face. There are six pre-drilled holes in the center of the top housing (between the protective hat channels). Align the top set of holes in the housing with the top set of holes in the hanger bracket (if the freeboard is 6" (15,2cm) then align the #6 holes with the top holes in the housing). When the hanger bracket is positioned on the housing, use the provided 3/4" (19mm) screws to attach (Fig 9.2).

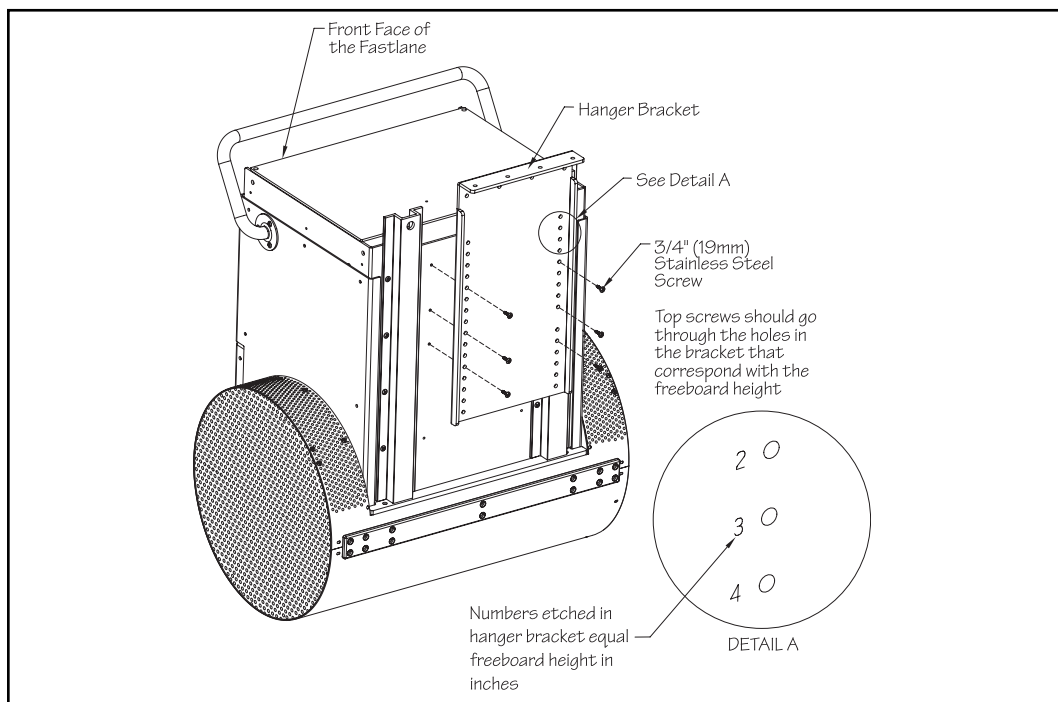

Fig. 9.2

- 9.3 This next step is best done with two people. Carefully lower the Fastlane Pro into the pool. Align the holes in the bracket with the holes in the hose cover tray. Use the provided 1/2" (12,7mm) screws to attach the top screws first and then the vertical screws next (total of 8 screws) (Fig 9.3).

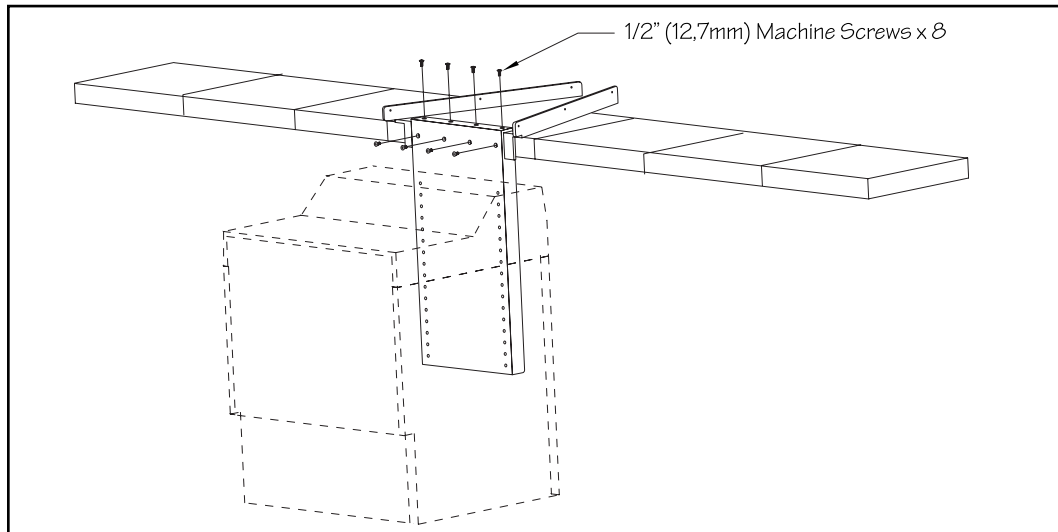

Fig. 9.3

- 9.4 Run the hydraulic hoses up and out of the pool and into the hose cover tray. Place the hoses under the hose clip (see Fig 8.2). Pull any excess hose out of the pool and out of the hose cover tray. Once the hoses are in the hose clip, secure the clip to the tray.
- 9.5 **Secure the stainless steel bond wire (that exits the top of the Fastlane Pro) to the bond lug attached to the hose cover tray. Attach a #8 AWG bare copper wire to the bonding lug (attached to the hose cover tray) and then incorporate that wire into the pool's bonding grid.**
- 9.6 Place the Fastlane Pro lid onto the top of the Fastlane Pro and use the six 3/4" (19mm) stainless steel screws that were provided (3 on each side) (See Fig 6.12).
- 9.7 Place the hose cover onto the hose tray and use the provided 1/2" (12,7mm) stainless steel screws to attach the cover to the tray (Fig 9.4).
- 9.8 If the distance between the Fastlane Pro and Power Unit is 25' (7,6m) or less, then the hoses attached to the Fastlane Pro will connect directly to the Power Unit (see section 12). If the distance between the Fastlane Pro and Power Unit is greater than 25' (7,6m), then additional run hoses will be required. Use the adapters provided with the hydraulic run hose to connect the hoses attached to the Fastlane Pro and the additional run hose.

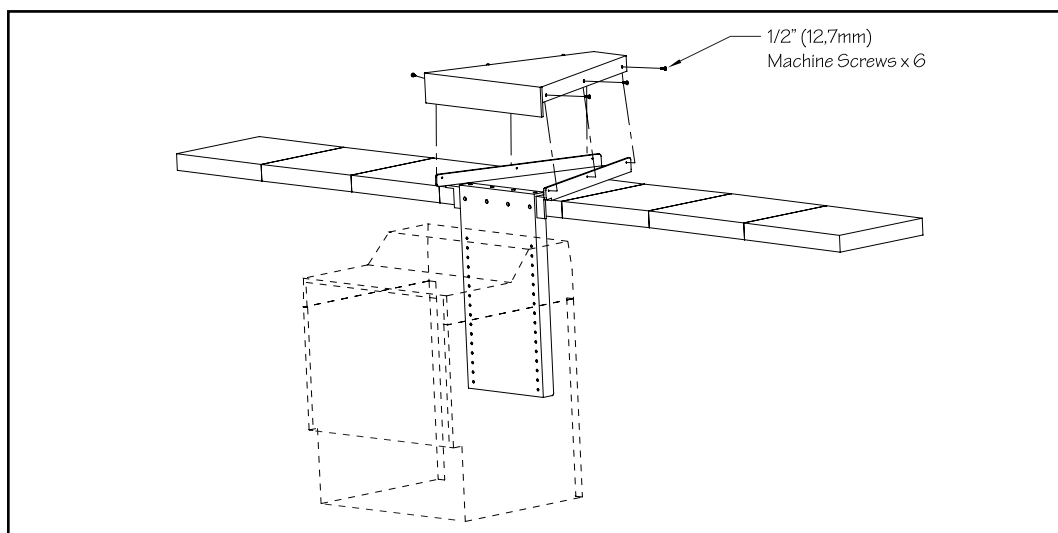

Fig. 9.4

Section 10

INSTALLATION OF THE HYDRAULIC POWER UNIT

10.1 Placement Considerations: The Power Unit should be placed on a flat, level surface. If placing outside, it is recommended the Outdoor Power Unit Weather Guard be purchased (see Fig 10.1), but should not be subject to driving rain. If placing indoors and at a level below the pool deck, such as a basement, a floor drain is mandatory to accommodate the unlikely event of a hole developing in the hydraulic hose creating a siphon. Whether placed indoors or out, this is an air-cooled unit and must have ample ventilation. Therefore, a minimum of 12" (30cm) air space must be provided on all sides of the Power Unit motor. In addition, while frequent access is not required, it is imperative the Power Unit is accessible. Access to the Power Unit Controller is essential.

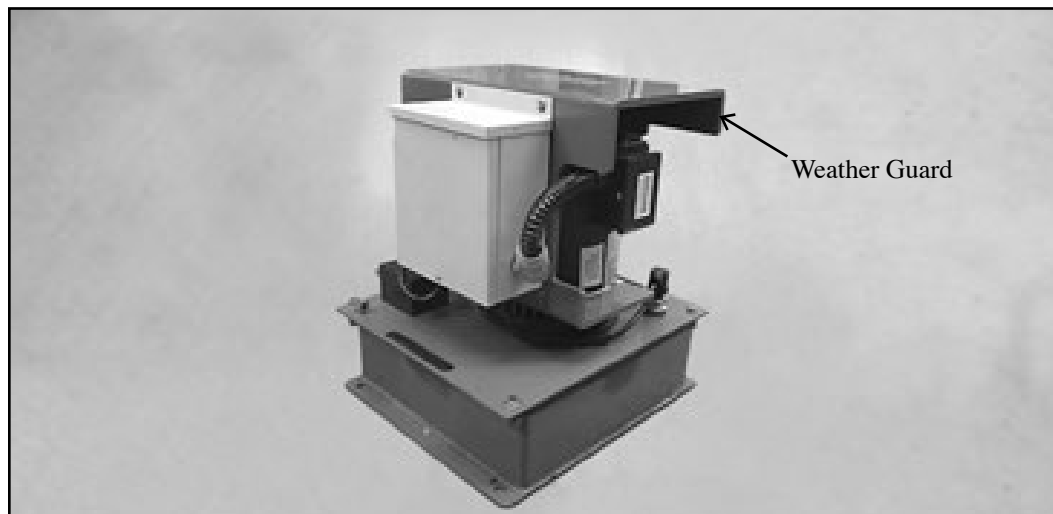
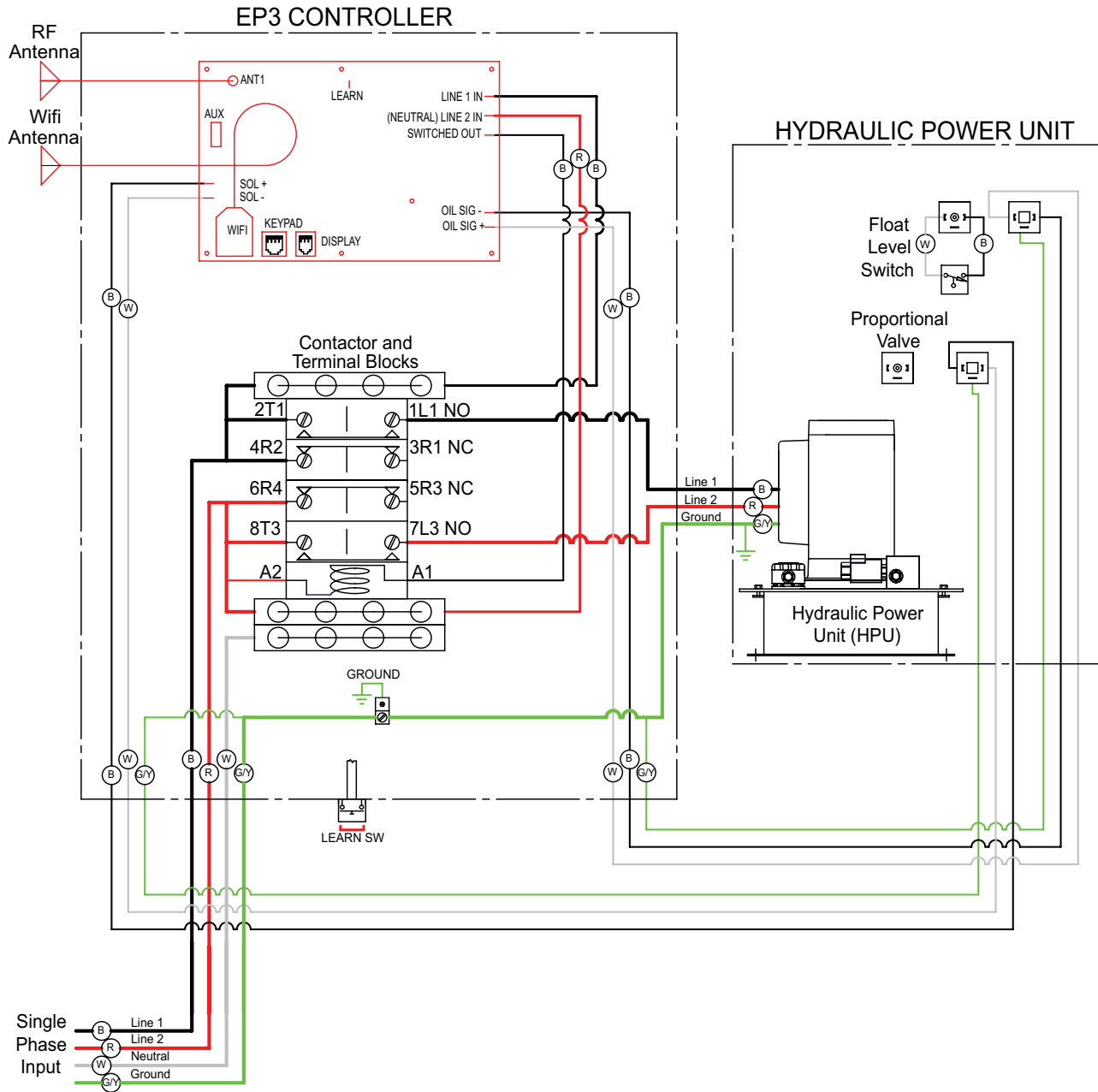

Fig. 10.1

- 10.2 Carefully remove the Power Unit from the packaging. Note: The Power Unit is very heavy. To remove the Power Unit open box top flaps, lay box on its side, open box bottom flaps, and slide the Power Unit out of the box sideways on the bottom foam.
- 10.3 Place the Power Unit in the selected position and verify that the hose connections are pointed in the direction you desire.
- 10.4 Have an electrician make the electrical connections using the whip provided. Make this connection by hard wiring to a disconnect or using an appropriate lock tight plug and socket. The Power Unit requires a single-phase 220V 30-amp GFCI (32-amp RCD) protected power supply. Verify the incoming voltage and wiring. Refer to the wiring diagram in Section 11A for 60Hz wiring connections and Section 11B for 50Hz wiring connections. The white wire will not be used in 50Hz applications

Section 11A ELECTRICAL REQUIREMENTS FOR THE UNITED STATES (60HZ) (and countries with similar electrical requirements)

A Ground Fault Circuit Interrupter (GFCI) is required for this product. A GFCI is a device that shuts off an electrical circuit when it detects that electricity is flowing along an unintended path. The path could be through a person or water. The purpose of this device is to reduce the chance of electrical shock. The Hydraulic Power Unit requires one single phase 220v 30amp GFCI protected service. All connections should be made by a licensed electrician.



Section 11B ELECTRICAL REQUIREMENTS FOR THE UK (50Hz) (and countries with similar electrical requirements)

The unique design of the Fastlane Pro facilitates sales to UK and international customers. The Fastlane Pro is shipped in kit form for easy assembly and installation into any new conventional pool following the detailed instructions provided.

The Fastlane Pro is ETL marked and CE listed.

A Residual Current Device (RCD) is required for this product. An RCD is a device that shuts off an electrical circuit when it detects that electricity is flowing along an unintended path. The path could be through a person or water. The purpose of this device is to reduce the chance of electrical shock. The RCD must have a rated residual operating current not exceeding 30mA. The MCB (breaker) that operates the Hydraulic Power Unit must be C-type, D-type, or motor rated. The Hydraulic Power Unit requires one single phase 220v 32amp RCD protected service. All connections should be made by a licensed electrician.

United States wire color-coding is different than international color-coding. The following chart identifies the color-coding used in the United States as it relates to the wire type. In addition, the wires of the controller have a short, colored sleeve wrapped around them to conform to the international color codes.

Wire Color	US Wire Type (60Hz)	Int. Wire Type (50Hz)
Black with Brown Sleeve	Hot or Live (120v)	Hot or Live (220v)
Red with Blue Sleeve	Hot or Live (120v)	Neutral
Green with Green/Yellow Sleeve	Ground	Earth

Should you have any questions, please call the Customer Service Department at 800-910-2714 (US), 0800-520-0196 (UK) or 610-497-4538 (Direct), or email us at poolhelp@endlesspools.com.

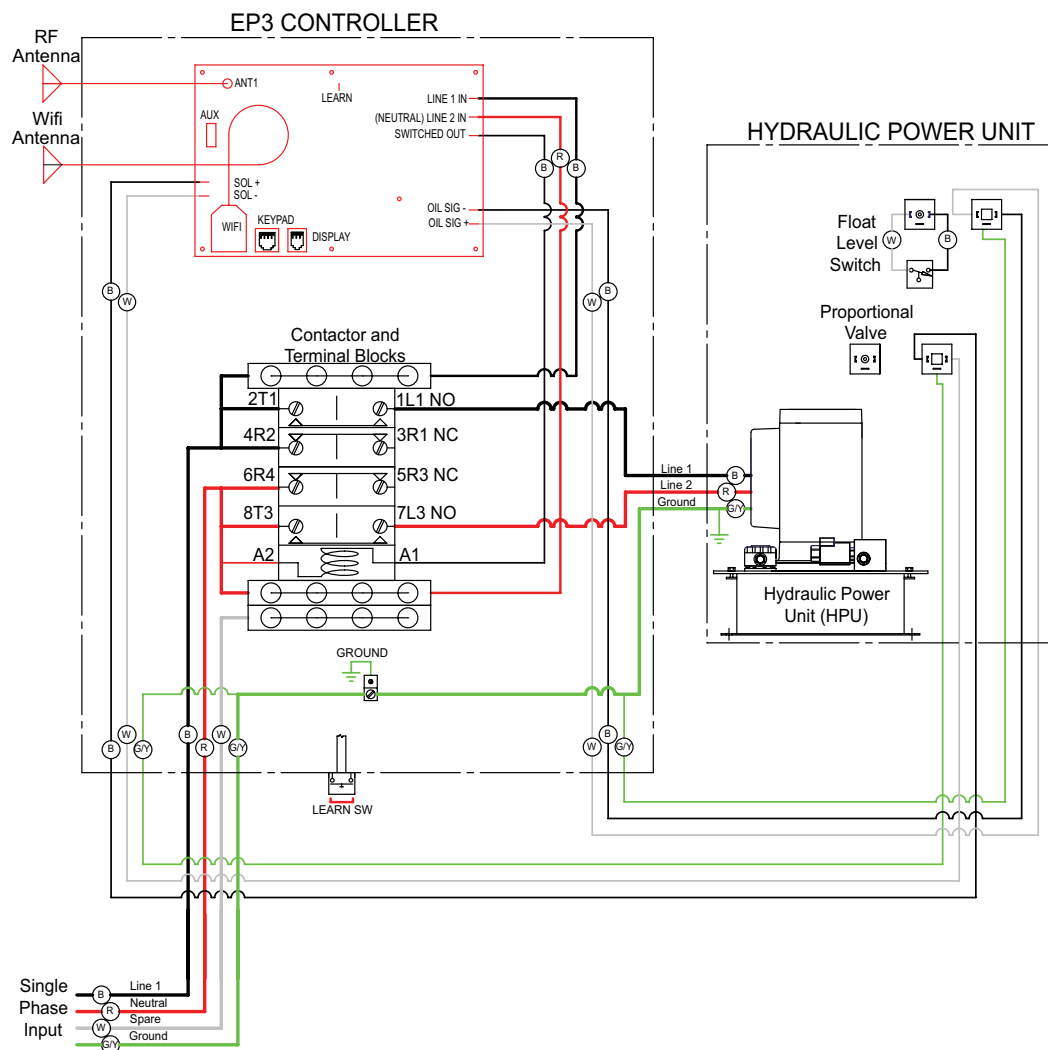

Section 12

EQUIPMENT START UP

- 12.1 Turn the circuit breaker for the Power Unit off. Connect the hydraulic hoses from the Fastlane Pro to the Power Unit. The low-pressure hose (connected to the Fastlane Pro) will have red tape wrapped around the hydraulic fitting. This hose will connect to the port on the fill cap. The high-pressure hose will connect to the port on the high-pressure manifold (blue box) (See Fig 12.2).

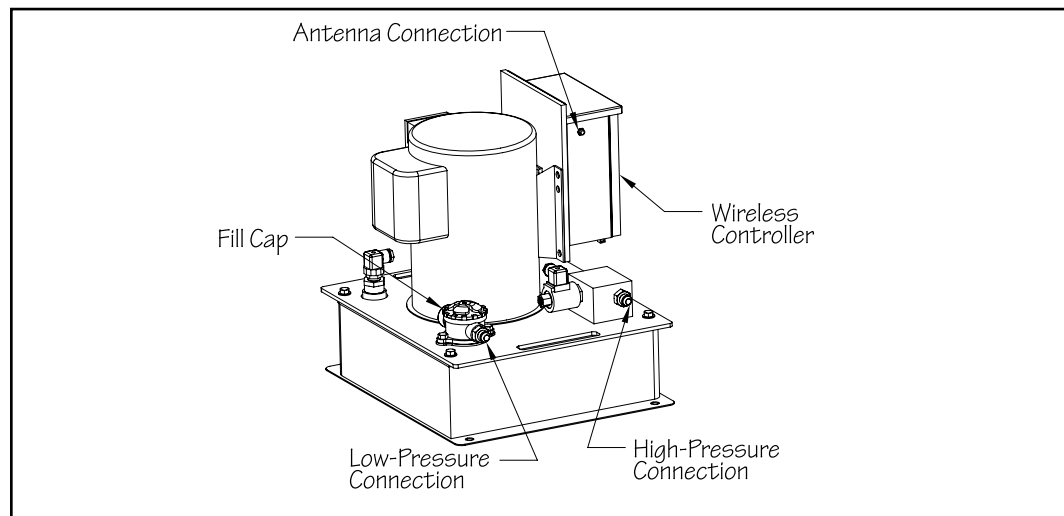

Fig. 12.2

If the hoses attached to the Fastlane Pro are to be directly connected to the Power Unit, then use the adapters (-8 female JIC x -6 male JIC) that were provided in the Accessories Kit.

If the 1/2" (12,7mm) run hoses are to be attached to the Power Unit, then these hoses will connect directly to the appropriate connections on the power unit.

- 12.2 Unthread the fill cap and remove the oil filter by pulling up on the clear tabs at the top and lifting it out of the opening of the fill cap assembly. Fill the Power Unit with approximately (4) gallons (14L) of hydraulic fluid (provided with the Fastlane Pro shipment). Once filled with hydraulic fluid, replace the oil filter making sure its fully seated in the fill cap assembly. Reinstall the fill cap and tighten. Install the antenna provided by threading it onto the coaxial connection on the left side of the Power Unit Controller's enclosure. Turn on the unit by pressing and holding the ON/OFF button (button in the center of the wireless transmitter). **If there is no swim current created in the pool after the unit has been running for one minute, increase the speed by pressing and holding the faster button (up arrow) until a current is produced.**
- 12.3 Once the Fastlane Pro is fully installed and operational, turn the system off and disconnect the hydraulic return hose (hose with red tape) which connects to the fill cap. Place the hose end into the 5-gallon (19L) bucket used to fill the power unit.
- 12.4 Turn on the Fastlane Pro, making sure to hold the hose firmly in your hand over the bucket. The returning hydraulic fluid will flow into the bucket. The system will automatically shut off when the float level switch inside the fluid reservoir is tripped.
- 12.5 TURN OFF POWER TO THE UNIT AT THE CIRCUIT BREAKER.
- 12.6 Reconnect the hydraulic hose to the power unit and tighten. Open the fill cap and add 2 cups of hydraulic fluid. Reinstall the fill cap and tighten.
- 12.7 Restore power to the equipment and test the unit. The system should stay on continuously. If the system shuts off, even intermittently, shut the power off at the circuit breaker and add an additional cup of hydraulic fluid. Restore power to the equipment and turn the unit on to test.

13.1 Bonding

Bonding is the joining of metal components in or around a pool and its associated equipment to bring them to the same electrical potential (equipotential). **The purpose of bonding is safety. It also prevents corrosion between different types of metal components.** Pools generally contain various grades of stainless steel, copper, galvanized metal etc. in or around them. This includes metal light rings, ladders, rebar in concrete as well as pool equipment such as pumps, heaters, and pool controllers.

All of these metallic components outside the pool should be connected by a solid copper wire. This wire and all of the metal components form a pool's bonding grid. Bond wires and connections may be readily visible in a pool's equipment area or on anything metal around the pool. To be compatible with chemically treated water, Endless Pools uses a stainless steel wire to connect the metal components inside the Fastlane Pro.

When two different types of metals are immersed in a conductive solution (pool water), they undergo what's called a galvanic reaction. The weaker metal (anode) will begin to dissolve; these particles will react with the conductive solution and coat the stronger metal (cathode). This will develop an electrical charge between the two metals called electrical potential and can be measured as voltage.

Safe: All metallic components in or around the pool **ARE** connected with bonding wires. This reduces the chance of galvanic reactions and prevents the build-up of electrical potential between these components. This in turn reduces the chance of a user receiving an electrical shock if they made contact with two metallic components in the pool at the same time.

Unsafe: One or more metallic components in or around the pool **ARE NOT** connected with bonding wires. The unconnected components become either an anode or cathode, leading to corrosion and the development of electrical potential. The electrical potential **IS DANGEROUS** as it only takes a small shock to incapacitate a pool user.

13.2 Bonding the Fastlane Pro

Wall Mount Fastlane Pro:

The Fastlane Pro, Hydraulic Power Unit, and Controller **MUST** be tied into the pool's bonding grid. Refer to Figure 13.1 for bonding the Wall Mount Fastlane Pro.

All Wall Mount Fastlane Pro shipments include bonding clamps to be attached to each threaded rod of the wall mount bracket. The threaded rods of the bracket must be tied into the pool's bonding grid. Before shooting gunite, #8 solid copper must be attached to each bonding clamp. These wires will then be attached to a bonding connection that's incorporated into the pool's bonding grid. Once the Fastlane Pro is installed in the pool, the stainless steel wire that exits the top of the unit must be attached to one of the threaded rods. Making this connection will ensure that the metal components of the Fastlane Pro (inside the pool) are connected to the pool's bonding grid.

Additionally, a second copper wire from the pool's bonding grid must be attached to the Hydraulic Power Unit and Controller. This is typically done by extending the bond wire from the existing pool equipment (heater, pump, etc.) and attaching to the bonding connections located on the Hydraulic Power Unit and Controller. The Endless Pools equipment is properly bonded when the Fastlane Pro, Hydraulic Power Unit, and Controller are tied into the pool's equipotential bonding grid. This should be verified by testing the continuity between all metallic components around the pool (refer to Figure 13.3 for testing procedure)

Deck Mount Fastlane Pro:

The Fastlane Pro, Hydraulic Power Unit, and Controller **MUST** be tied into the pool's bonding grid. Refer to Figure 13.2 for bonding the Deck Mount Fastlane Pro.

All Deckmount Fastlane Pro shipments include a copper bonding lug that's pre-attached to the hose cover tray (deck plate). Once the Fastlane Pro is installed into the pool, the stainless steel wire that exits the top of the unit must be attached to the bonding lug on the hose cover tray. A #8 solid copper wire is then attached to the bonding lug which must tie into the pool's bonding grid. This is typically done by attaching the copper wire to a connection at the pool's existing equipment (pump, heater, etc.) that's presumably already incorporated into the bonding grid of the pool.

Additionally, a second copper wire from the pool's bonding grid must be attached to the Hydraulic Power Unit and Controller. This is typically done by extending the bond wire from the existing pool equipment (heater, pump, etc.) and attaching to the bonding connections located on the Hydraulic Power Unit and Controller. The Endless Pool's equipment is properly bonded when the Fastlane Pro, Hydraulic Power Unit, and Controller are tied into the pool's equipotential bonding grid. This should be verified by testing the continuity between all metallic components around the pool (refer to Figure 13.3 for testing procedure).

Section 13 WALL MOUNTED FASTLANE PRO BONDING

1. Stainless steel bonding wire that exits the top of the Fastlane attached to threaded mounting rod.
2. Bonding clamps attached to threaded mounting rods tied to pool bonding grid with #8 solid copper wire.
3. Hydraulic Power Unit and Controller tied to pool equipment with #8 solid copper wire.

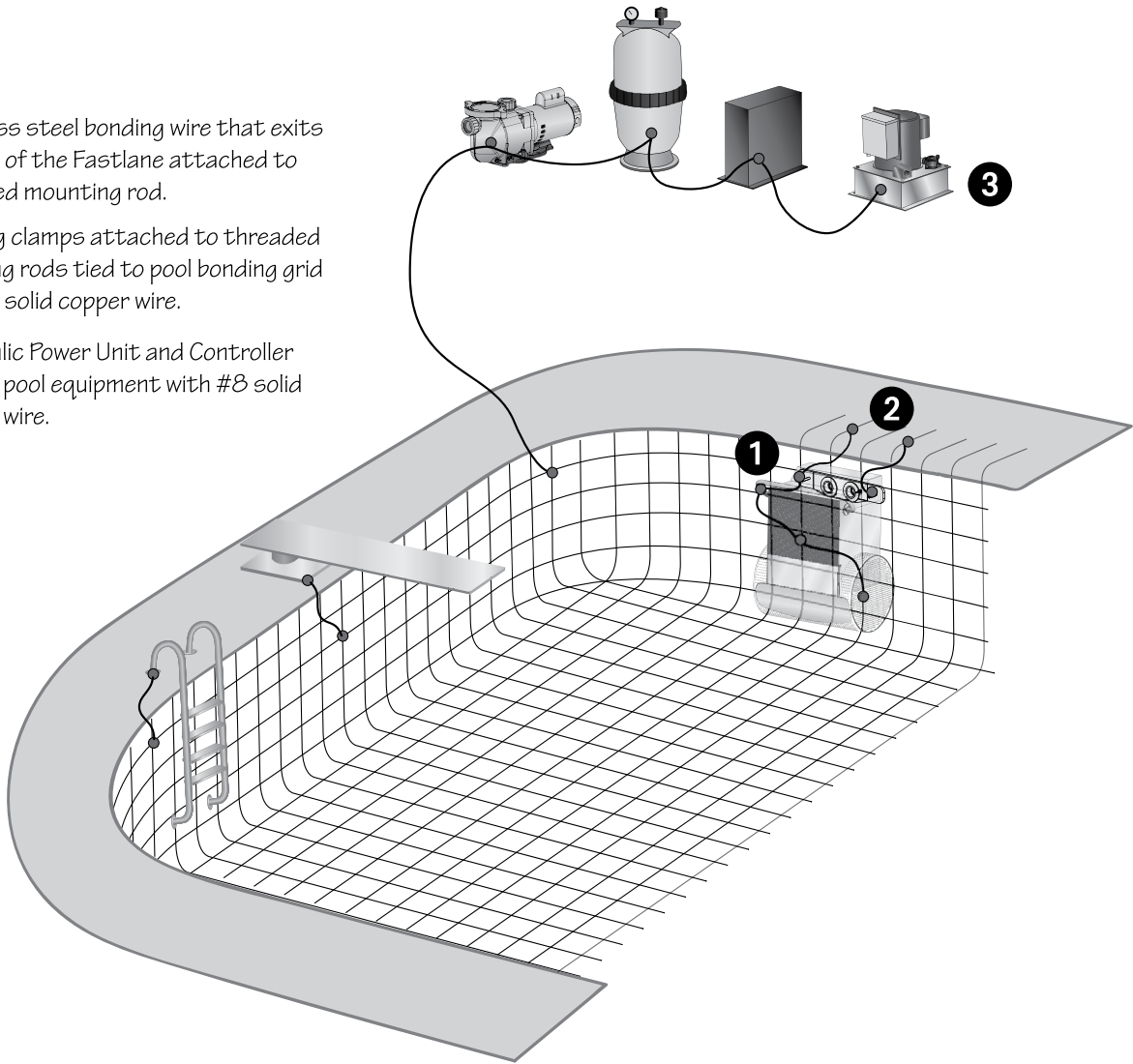

Fig. 13.1

Section 13 DECK MOUNTED FASTLANE PRO BONDING

1. Stainless steel bonding wire that exits the top of the Fastlane attached to bonding lug on the hose cover tray.

2. Bonding lug on hose cover tray tied to pool equipment with #8 solid copper wire.

3. Hydraulic Power Unit and Controller tied to pool equipment with #8 solid copper wire.

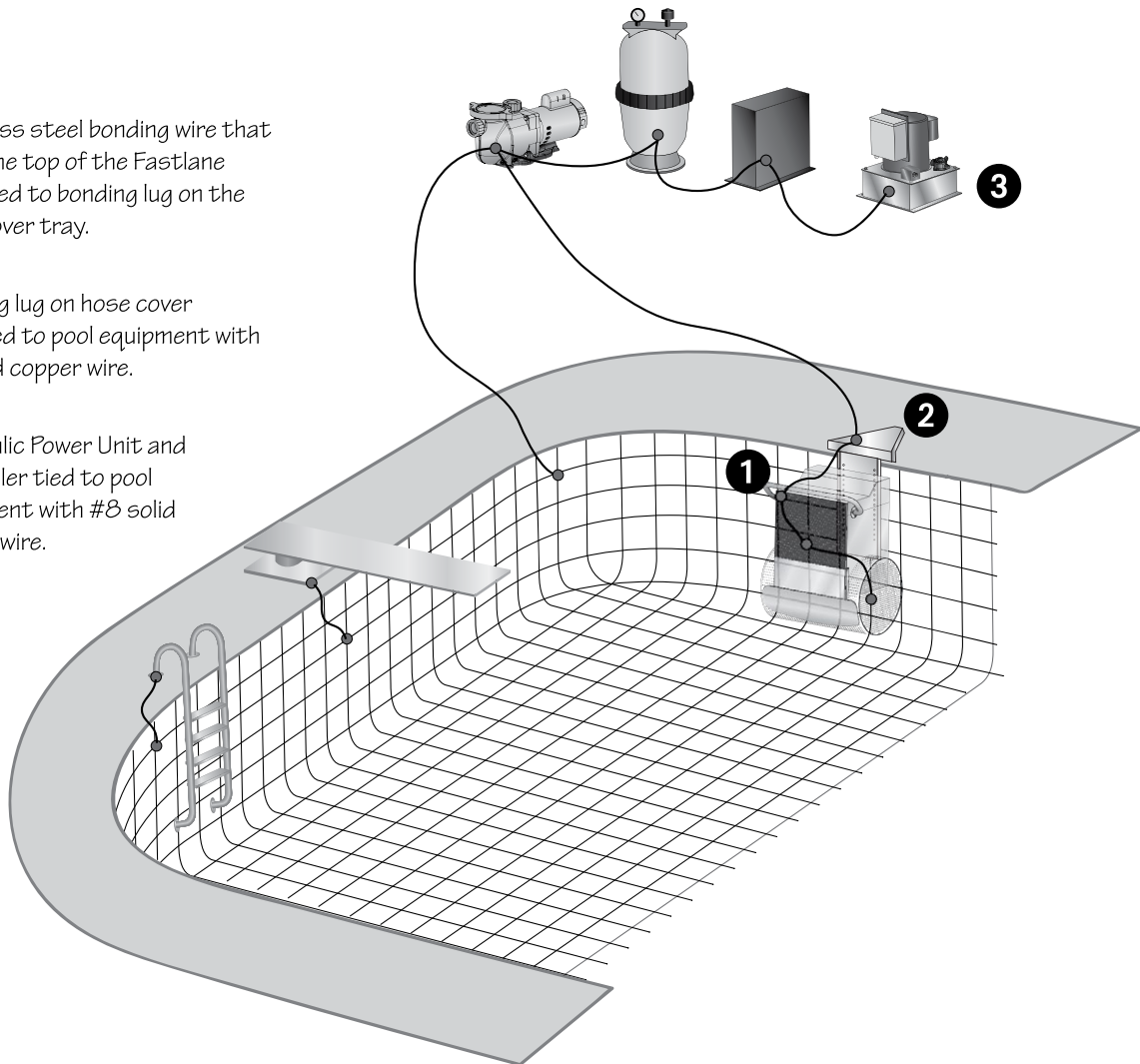
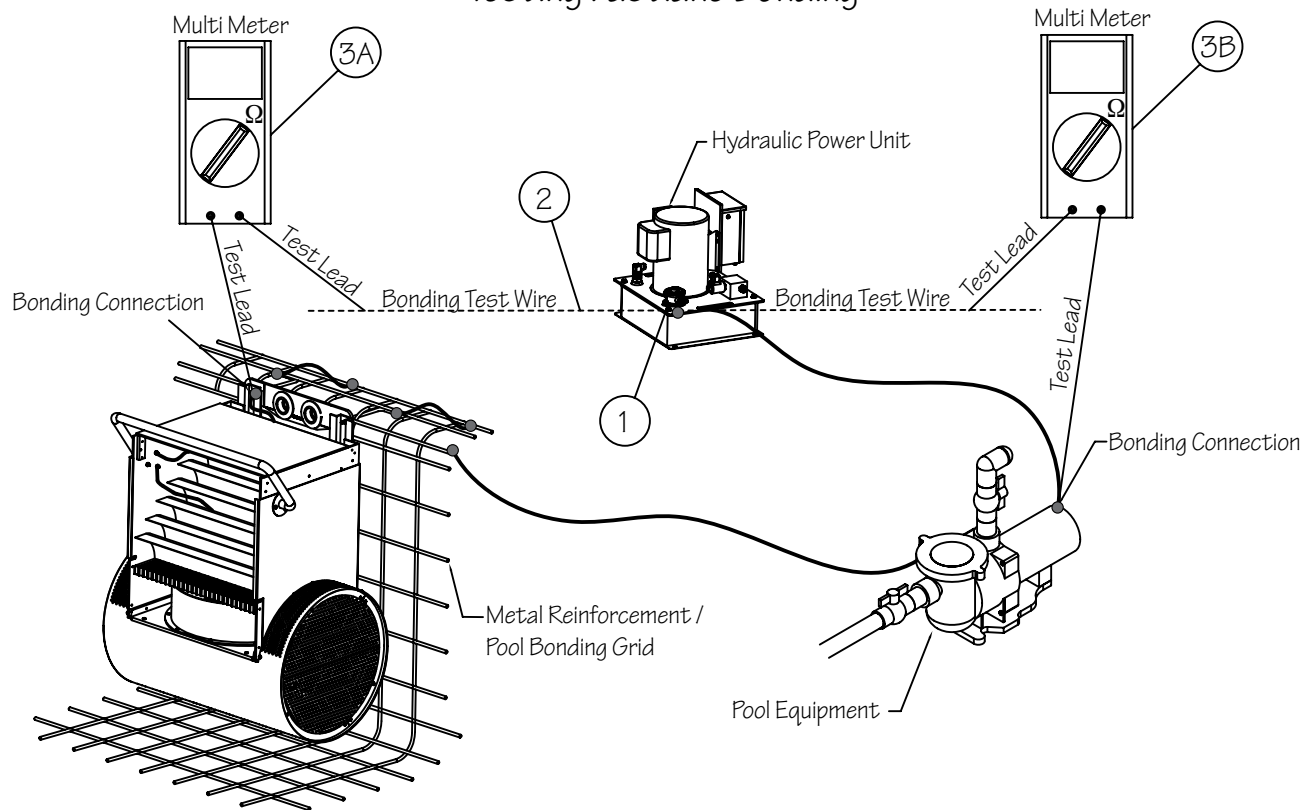

Fig. 13.2

Testing Fastlane Bonding



- 1) Attach stainless steel "Bonding Test Wire" to the bonding lug located on the hydraulic power unit.
- 2) Run the test wire across the pool deck to the Fastlane bonding connection. For Wall Mount units, the connection will be at the threaded mounting rod (as shown). For Deck Mount units it will be at the hose cover tray.
- 3A) Set the multimeter to resistance (continuity Ω). Place one test lead on the test wire and the other test lead on the Fastlane bonding connection point (where the stainless steel wire that exits the top of the Fastlane is attached). (Refer to Test Results Below)
- 3B) Run test wire to the existing pool equipment (pump, heater, ladder, etc) to test continuity between the hydraulic power unit and pool equipment. Place one test lead on the test wire and the other test lead at the bonding connection at the pool equipment. (Refer to Test Results Below)

Test Results:

Continuity = Properly Bonded Unit

No Continuity / Open Line = Improper Bonding OR Disconnected Bonding Circuit. This requires repair prior to using the FastLane.

Fig. 13.3

Section 14 USING YOUR FASTLANE PRO

Two wireless transmitters are included with the Fastlane Pro shipment which are used to turn the unit On/Off and adjust the speed of the swim current. Press and hold the On/Off button (middle power button) to turn the unit on. Press and hold the faster button (up arrow) to increase the speed of the swim current. Press and hold the slower button (down arrow) to decrease the speed of the swim current. Turn the unit off by pressing and holding the On/Off button.

The hydraulic power unit controller is equipped with a built-in timer, shutting the unit off after 30 minutes. The Fastlane Pro will “remember” the speed of the swim current at which it was turned off and will default to that same speed when the unit is turned back on.

Section 15 PRODUCT INSTALLATION INFORMATION

The product installation information **MUST** be completed by the installer prior to using the product.

1. Fill out the installation information below:

<p>MONTH/YEAR INSTALLED _____</p>
--

2. Hand the installation manual containing the above information to the customer to be stored with other important pool related documentation.

Section 16 GENERAL INFORMATION

Once installed, the Fastlane Pro will provide years of exercise and fun with minimal maintenance. Clean the intake grills of leaves as needed and wipe down the stainless steel cylindrical base and grab rail with warm water, a Scotch Brite pad, and brisk rubbing. Clean the acrylic housing with any typical non-ammonia, non-abrasive kitchen cleanser. Periodically, check all electrical and ground wire connections and test the GFCI circuit breaker for proper function.

It is important for the long-term operation of your Fastlane Pro that your pool water be properly balanced and in accordance with normal pool industry standards. In addition, it is imperative that the Fastlane Pro be bonded to the pool bonding grid.

Endless Pools is an industry leader in customer service, should you ever have questions or concerns about your Fastlane Pro, please contact our Customer Service Department at 800-910-2714 (US), 0800-520-0196 (UK) or 610-497-4538 (Direct).

Section 17

SCHEDULED MAINTENANCE

- 16.1 **Hydraulic Motor and Fluid Maintenance.** We recommend the hydraulic motor, which is located in your swim unit and submerged underwater, be replaced after six years of usage. We also recommend changing the non-food grade, biodegradable vegetable oil and filter in the Power Unit after every 500 hours of use.
- 16.2 **Grill Cleaning.** Should you perceive a reduction in speed of your Fastlane Pro, it may be caused by a reduction in water flow due to a blockage of the inlet assembly of the cylindrical base. Because the underside of your Fastlane Pro will be drawing in water, it may occasionally become necessary to clean the cylindrical base of any debris or leaves that may have been in your pool when the Fastlane Pro was in operation. With the Fastlane Pro unit turned off, this is very easy to accomplish while in the pool.
- 16.3 **Cold Weather Maintenance.** At the end of the swimming season, it is recommended the Fastlane Pro Swim Unit be removed from the swimming pool and winterized. For specific instructions, please contact our Customer Service Department at 800-910-2714 (US), or 610-497-4538 (Direct).
- 16.4 **Use of Salt-chlorine generators.** Placing a Fastlane Pro in a pool sanitized using a salt-chlorine generator creates increased risk of a hydraulic system failure and oil leaks. Any Fastlane Pro placed in this type of environment must be properly bonded, and water chemistry must be closely monitored. As stated in our warranty, pH levels must be maintained between 7.4 and 7.8, total alkalinity between 80 and 120 ppm, salt chlorine levels below 4000 ppm, and total dissolved solids below 7000 ppm. Failure to properly bond the Fastlane Pro or maintain proper water chemistry will void the warranty.

If you are using a salt-chlorine generator, please complete the following tasks:

- Remove and inspect your Fastlane Pro unit annually. Once removed, rinse the Fastlane Pro with fresh water before storing for the off-season.
- Replace the underwater hydraulic motor and submersible hoses every two years.
- Ensure that the fluid level in your power unit is no more than one cup above the float level switch. This simple procedure ensures that any oil leak is minimized

- 16.5 **Cathodic Protection Maintenance Program.** The Fastlane Pro has been fabricated using the finest, most durable materials and has been designed to meet the most stringent safety standards, including VGB 2008. However, unbalanced water chemistry and salt chlorine generators can shorten the lives of these materials if the unit has not been properly bonded. Endless Pools has provided a sacrificial anode to draw any corrosion to itself and away from the Fastlane Pro. To maximize the life span of your Fastlane Pro, it is imperative that the Fastlane Pro be properly bonded and the sacrificial anode be replaced after it has given up half its mass. Endless Pools offers a Preventative Maintenance Program.

This program will automatically send you a “sacrificial anode” on a regular basis for a nominal charge to help prevent product damage due to electrolysis. Enrollment in this program is recommended if the Fastlane Pro is installed in a pool with a salt-chlorine generator. Contact Endless Pools Customer Service at 800-910-2714 to enroll in this program.

Section 18 SUCTION OUTLET FITTING SERVICE INSTRUCTIONS**Suction Outlet Fitting Information:**

Model: Fastlane Pro
Suction Outlet Fitting # 196310
Suction Outlet Fitting Fastener # 710980

Suction Outlet Fitting Replacement Instructions

Service Access: The use of adhesives or other attachment methods that prevent access to suction piping or suction outlet fitting components requiring periodic servicing is prohibited.

The suction outlet fitting shall be replaced at or before the end of the 25 year service life. The suction outlet fitting and fasteners securing the suction outlet fitting should be inspected before each use throughout its service life. The suction outlet fitting **MUST** be repaired or replaced if it's missing, loose, dented, cracked, or broken. The fasteners and corresponding receptacles **MUST** be replaced or repaired if damaged.

When service is required to replace the suction outlet fitting, it shall be done so with replacement fasteners provided by the manufacturer. The fasteners securing the suction outlet fitting are **#10 x 1" (25mm) 316 Stainless Steel Phillips Flat Head Machine Screws**. The fasteners **MUST** be installed using a #2 Phillips head screwdriver. The recommended torque for the fasteners is **25 inch-pounds**. **DO NOT USE POWER TOOLS TO INSTALL FASTENERS**. Start installation of the fastener by hand to ensure proper thread engagement and to prevent cross threading.

1. Remove the top lid of the housing by removing the screws.
2. Remove the vertical water conditioning grill.
3. Remove the bond wire, attached to the motor mounting bracket of the base assembly, from the grab bar screw on the inside of the housing.
4. Remove the upper housing from the base assembly by removing the screws that secure the housing to the base assembly.
5. Remove the outer arcs and stainless steel discs from each side of the suction outlet grill.
6. Remove the bonding wires attached to the stainless steel disks.
7. Remove the suction outlet grill from the motor plate assembly by removing the nuts from the underside of the motor plate and removing the 1" (25mm) Phillips Flat Head Machine Screws.
8. Replace the suction outlet grill and ALL fasteners securing the suction outlet grill following steps 1-7 in reverse order. **If ANY suction outlet fastener receptacle (screw hole) is damaged (stripped), it MUST be replaced with a new receptacle following the instructions below:**
 - 8.1 Mark hole 1/2" (13mm) away from damaged receptacle.
 - 8.2 Drill hole in suction outlet grill using 1/4" (6mm) drill bit.
 - 8.3 Drill hole in PVC motor plate assembly using 11/64" (4mm) drill bit.
 - 8.4 Use fasteners provided by the manufacturer to reinstall suction outlet grill.



Endless Pools • 1601 Dutton Mill Rd • Aston, PA 19014-2931
800-910-2714 US • 610-497-8693 fax • www.myendlesspool.com



Intertek



ANSI/APSP-16
VGB 2008

D30001 0820
© Copyright 2020 Wellness Marketing Corporation