



misulacOSMETICS | RETAIL & DISPLAY CONCEPT



The name “Misula” is expressly rooted in one of the foundational aspects of our brand: the connection to the territory in which we cultivate our raw materials and the unique nature of the raw materials that we use within the products that we create: the fact that they are local only to a very small area of the Mediterranean, in Italy, right in the heart of the territory of the Pollino National Park, near the town of Castelluccio Superiore.

One of the most unique characteristics of the town of Castelluccio are the so-called “mìsule” (the plural form of mìsula), a word which in the local dialect refers to the ancient squared terracing placed inside the historic center of the town; mìsule were essentially small, private cultivation sites where medicinal plants and herbs, were traditionally grown.

Cultivation was made possible by the genial management of spring waters which, through canals and artificial ducts, irrigated the mìsule of the town’s inhabitants in strictly pre-established days and times.

This historic practice is still alive today, as some veins of water flow - in the duct or out in the open air - following the ancient paths that have been used for centuries.

In fact, for centuries, the mìsule have represented an important aspect of hydrogeological preservation of the rocky ridge on which the town of Castelluccio Superiore stands; they are places that naturally lend themselves to the preservation of local biodiversity, which is crucial to the status of a UNESCO World Heritage site..

BRAND & LOGO DESIGN

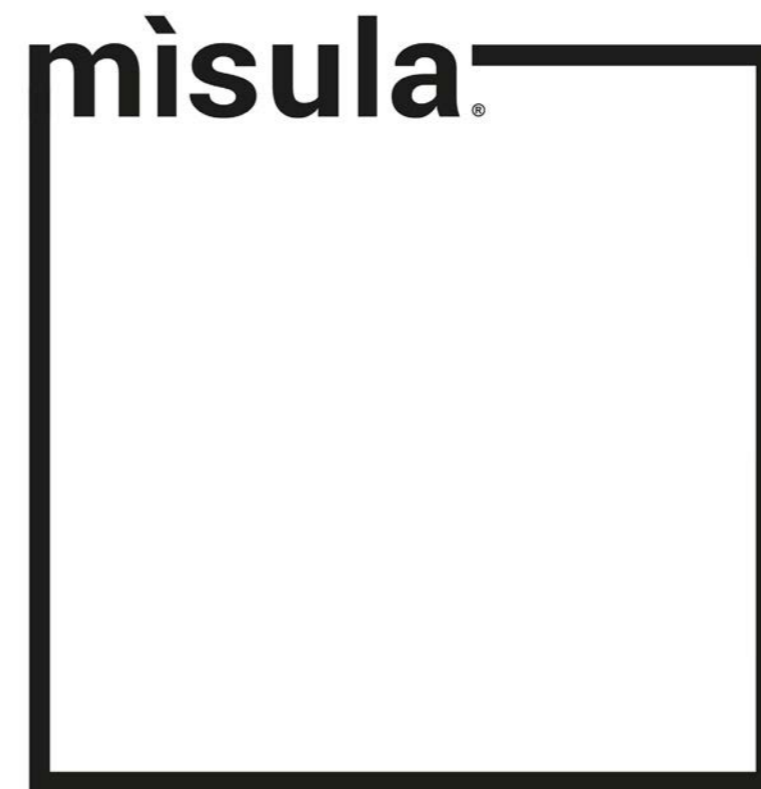



TAKING CARE
OF YOUR SKIN
IS MORE
IMPORTANT THAN
COVERING IT UP.



ADVERTISING
& SIGNAGE

WE ARE DEDICATED TO PROVIDING
OUR CUSTOMERS WITH ONLY
TOP-TIER PRODUCTS, BASED ON THE MOST
CURRENT SCIENTIFIC KNOWLEDGE
**OURS IS A FRESH APPROACH
TO LUXURY SKINCARE:
WHEN USING MEDITERRANEAN
BOTANICAL INGREDIENTS
IN THEIR PUREST FORM
LEVERAGING THE POWER OF NATURE
WITHIN THE CONTEXT OF SCIENCE
AND OFFERING PRODUCTS
THAT ARE NOT ONLY GOOD
FOR YOUR SKIN, BUT ALSO
GOOD FOR OUR PLANET**

MISULACOSMETICS.COM FRAMECOSMETICS.COM



FRAME

ADVANCED
MEDITERRANEAN
PRO-AGEING SOLUTIONS

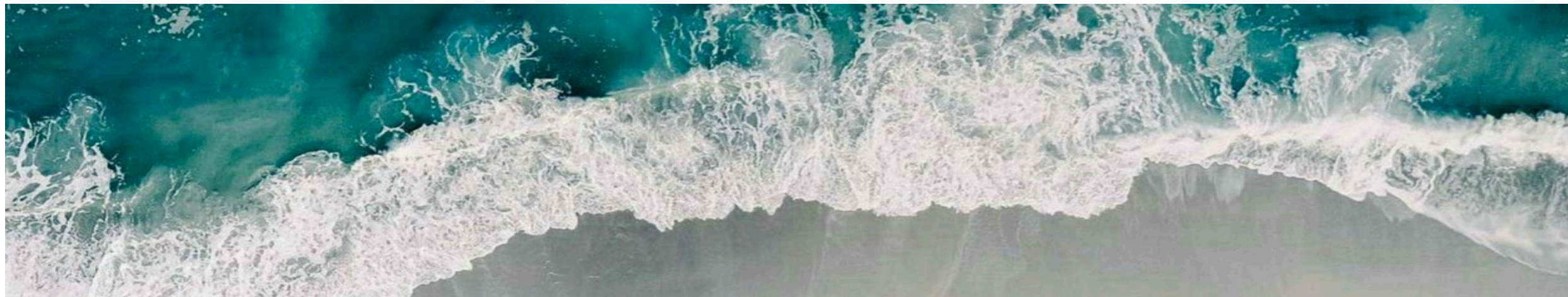

NATURAL ELEMENTS



PACKAGING ELEMENTS

misula



PK PREVENTION KIT
ROUTINE FOR EARLY ADULTHOOD

MK MAINTENANCE KIT
ROUTINE FOR MIDDLE ADULTHOOD

RK RESTORING KIT
ROUTINE FOR MIDDLE AND LATE ADULTHOOD

K KIT CODE

P PREVENTION CODE

M MAINTENANCE CODE

R RESTORING CODE

U UNIVERSAL CODE

S SKINCARE SUPPLEMENTS CODE

N APPLIED NUTRACEUTICALS CODE

H HERBAL EXTRACTS CODE

D DEVICES CODE

1	2	3	4	5
6	7	8	9	10

DEVICES SUBCODE

1	2	3	4	5		
51	52	6	7	8	9	10
53	54					

PRODUCTS SUBCODE

PK PREVENTION KIT
FOR EARLY ADULTHOOD



RK INTENSIVE RESTORING KIT
FOR MIDLIFE / MATURE AND LATE ADULTHOOD



MK MAINTENANCE KIT
SEASON ROUTINE



ABACUS

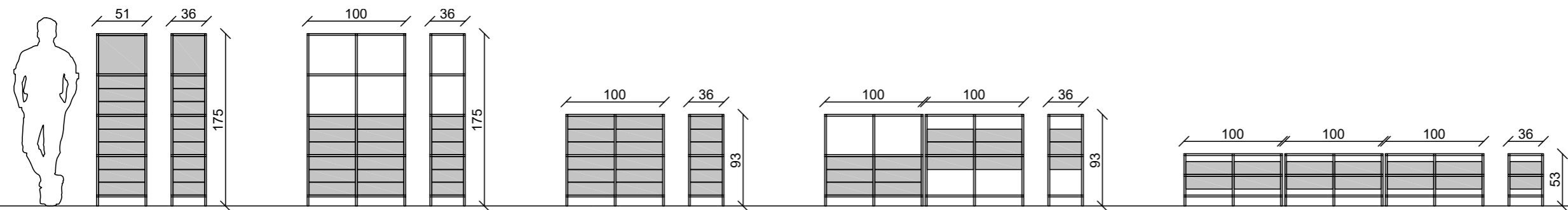
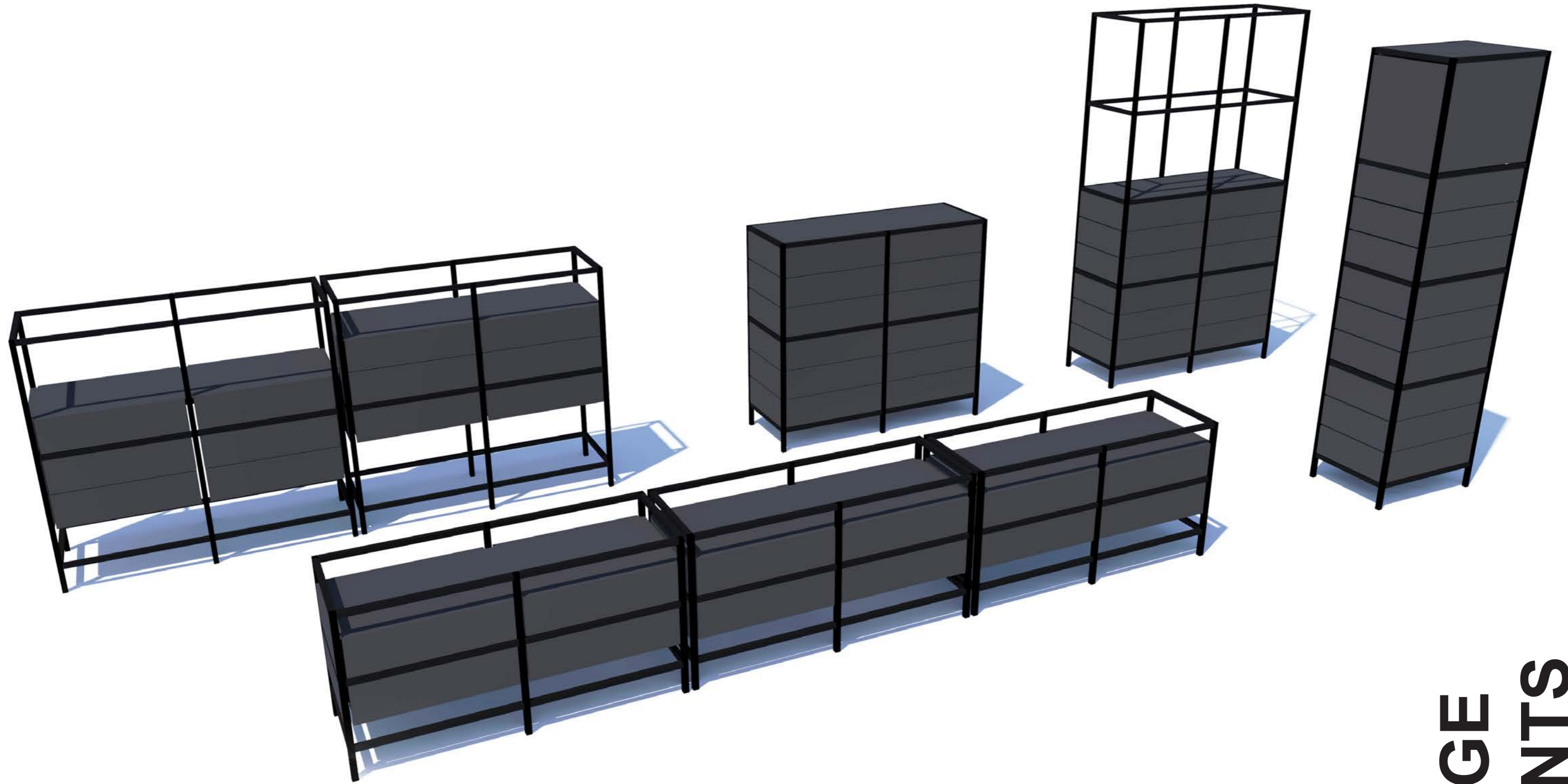

STORAGE ELEMENTS

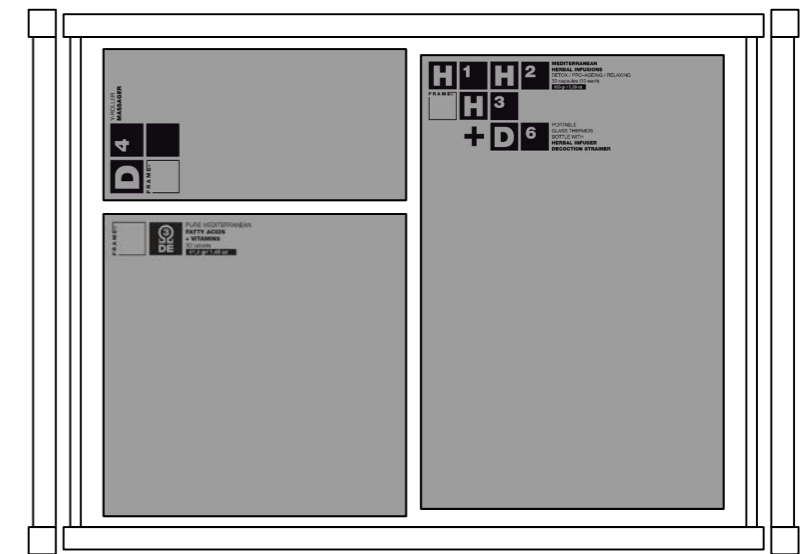
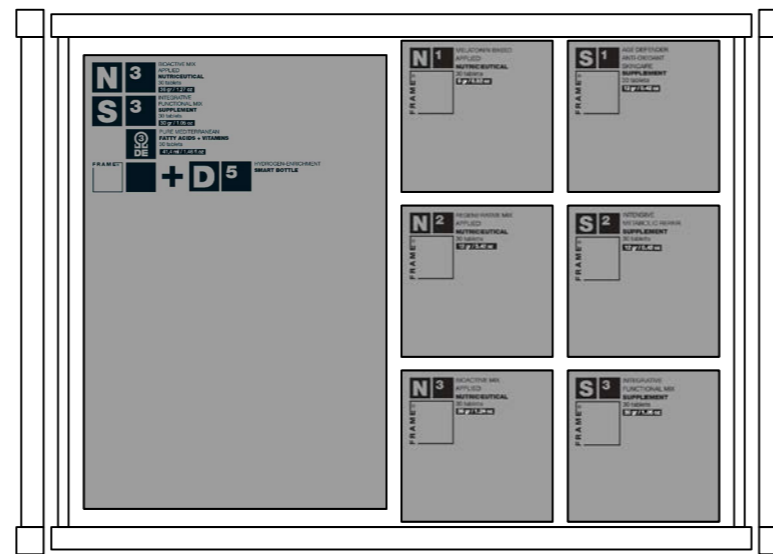
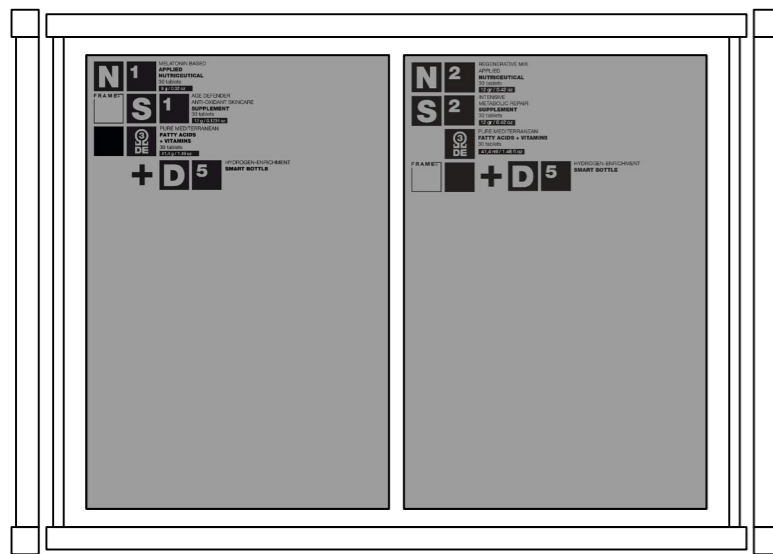
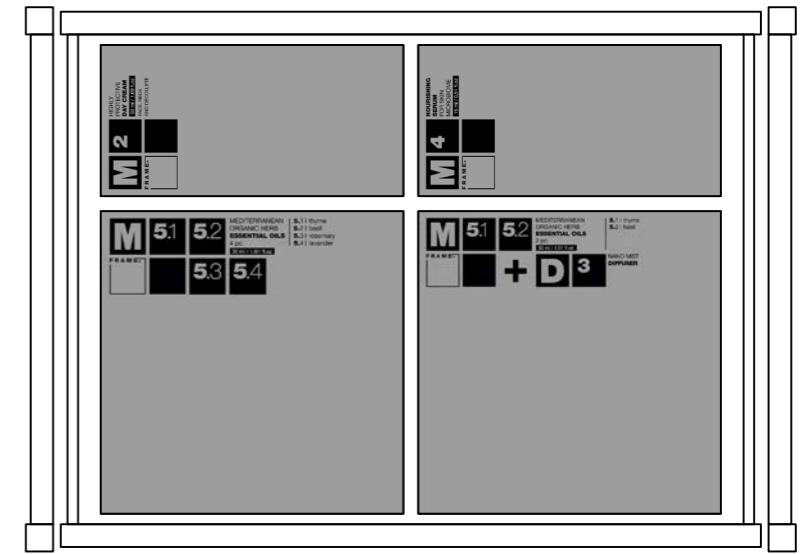
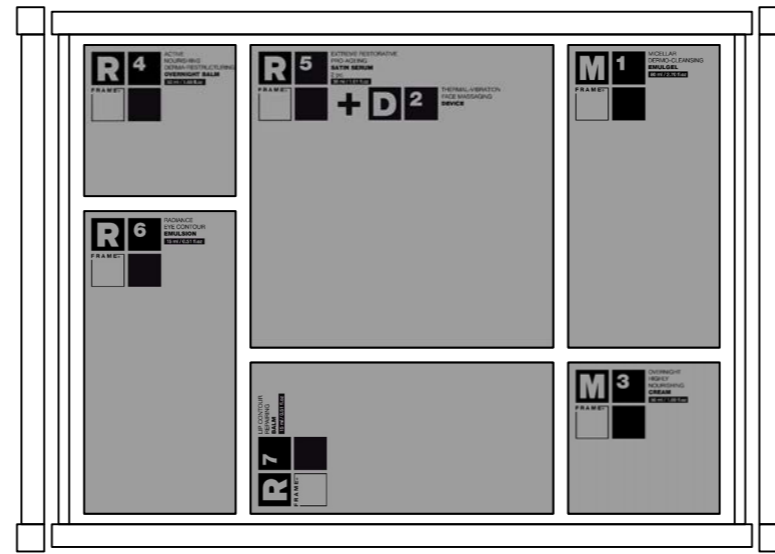
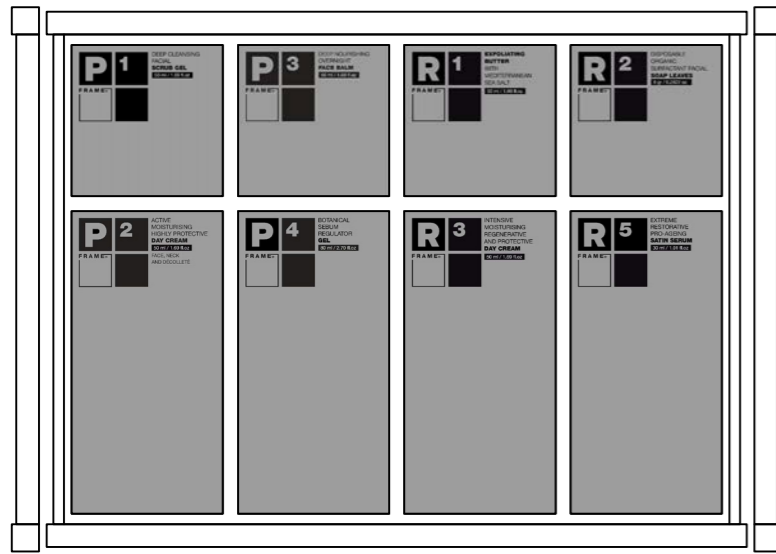

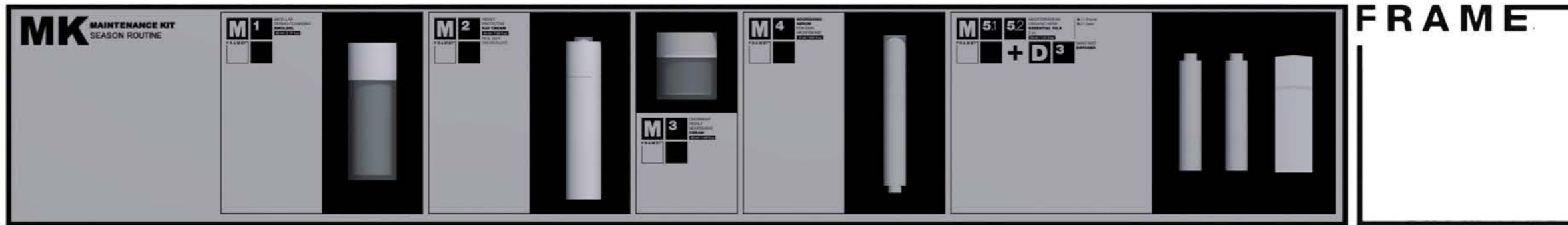

FRAME

ADVANCED MEDITERRANEAN PRO-AGEING SOLUTIONS

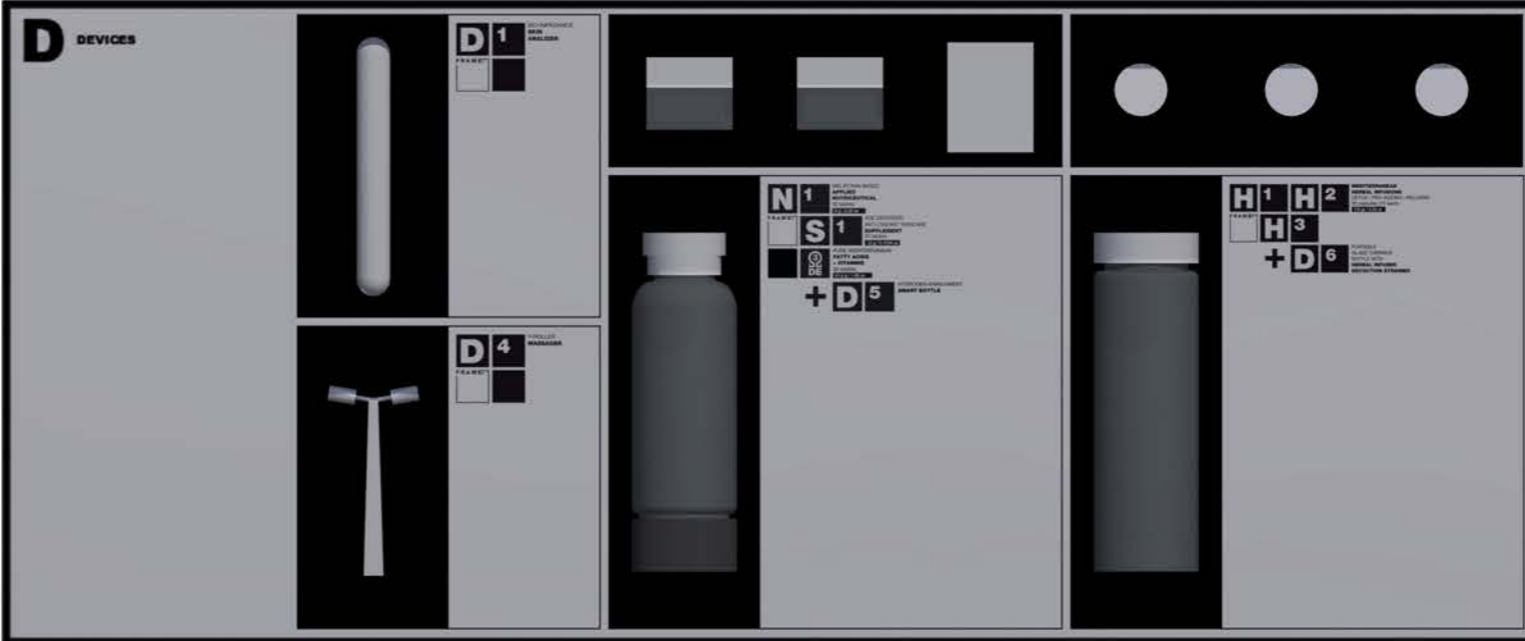
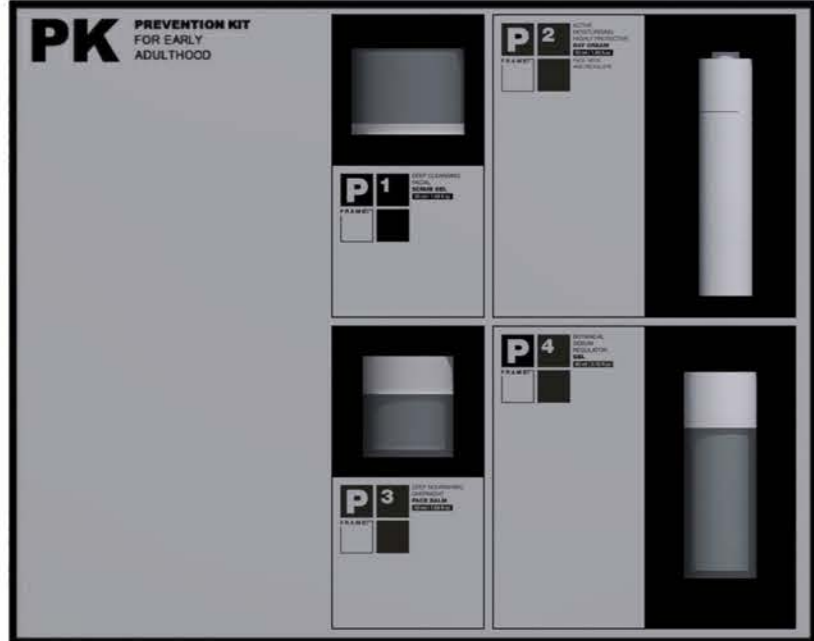
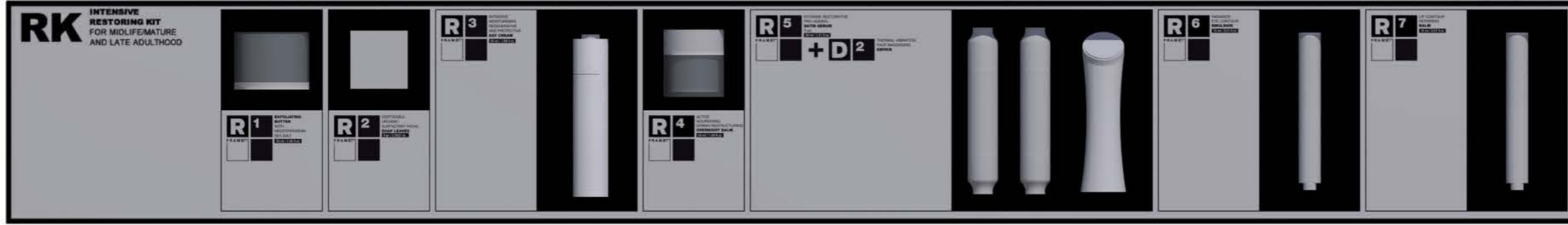

The Mediterranean diet has been inscribed among Intangible Cultural Heritage of Humanity since 2010, in recognition of its correlation with a better and longer quality of life. In motivating **UNESCO's** decision, which was reached after decades of scientific evidence and years of candidacy, the United Nations emphasized, above all, the understanding of the concept of 'lifestyle' in the term diet. The UN underlined the fact that, although many dietary choices are intrinsically health-related, this alone is not sufficient: the Mediterranean 'diet' is not simply what one eats but a way of understanding life as a whole; it is a collection of virtuous behaviors and habits that regulate our daily rhythms and rituals. This prestigious recognition by **UNESCO** rewarded the entire Mediterranean region, especially Italy, which is renowned throughout the world as an example of balance between diet, conviviality and lifestyle. It is, therefore, no coincidence that here in Italy the partnership among four important companies specializing in the production of plant active ingredients - **Sveba, Osun Solutions, Maylea, Evra, and Nvh Italia** - has resulted in today's launch of **FRAME[®], Advanced Mediterranean Pro-Ageing Solutions**. It is the first complete range of products and services for wellbeing, longevity, and beauty devised to embrace the challenge set by **UNESCO's** recognition and respond to the complexities it entails. The name **FRAME[®]** evokes the roots and composite identity of the brand, founded in order to merge the history and expertise of companies boasting over twenty years of technical and scientific experience with a new, positive approach to the culture of ageing, which encompasses the Mediterranean spirit.

framecosmetics.com

DISPLAY

100

235

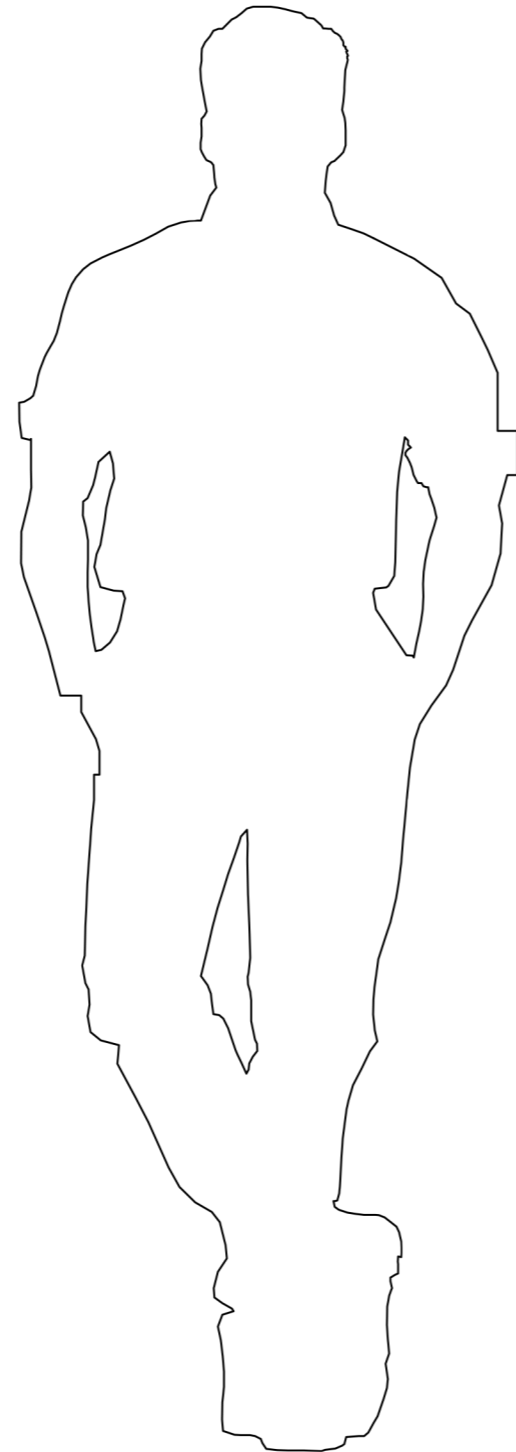
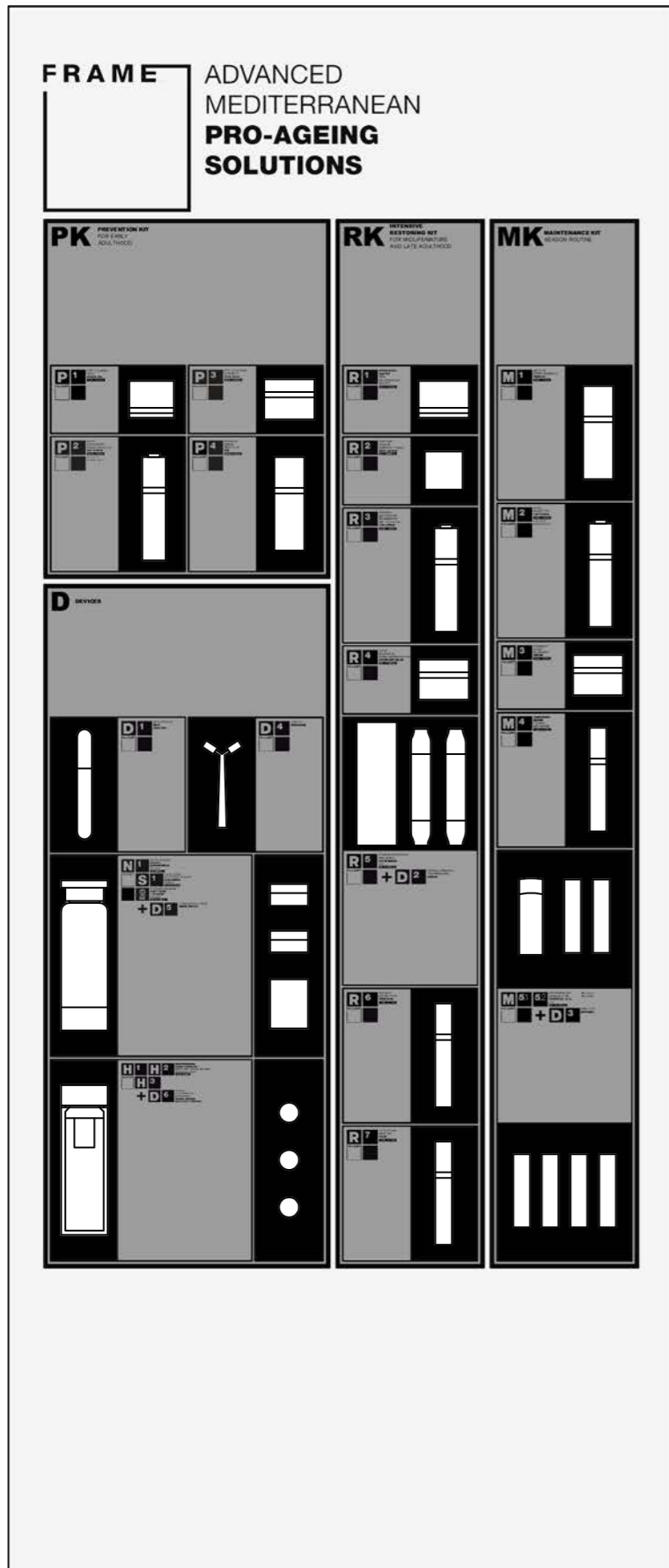

MINI

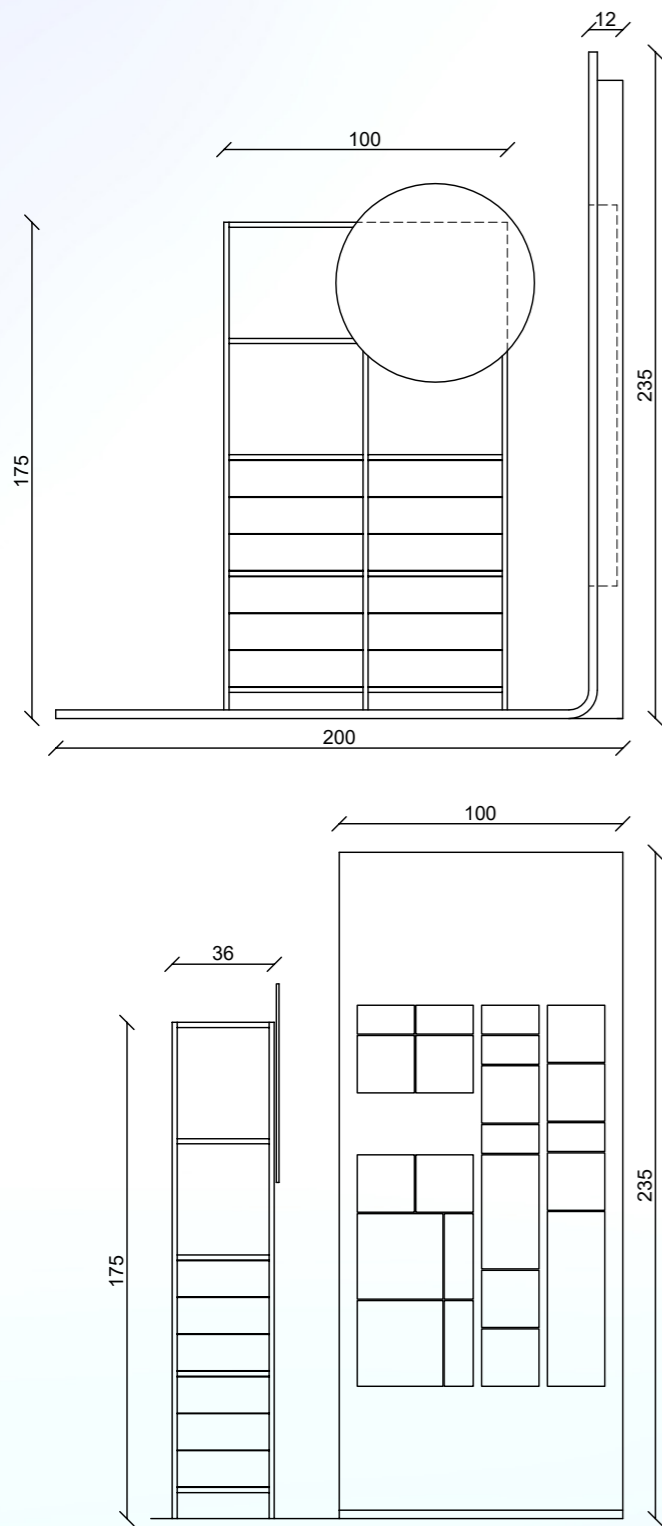

135

220

PK PREVENTION KIT
FOR EARLY ADULTHOOD

RK REVERSE REWINDING KIT
FOR MIDDLE-AGED AND LATE ADULTHOOD

DK DEVICES

PK1 **PK2** **PK3** **PK4**

RK1 **RK2** **RK3** **RK4** **RK5** **RK6** **RK7** **RK8**

DK1 **DK2** **DK3** **DK4** **DK5** **DK6** **DK7** **DK8** **DK9** **DK10**

FRAME

MK MAINTENANCE KIT
EASIER ROUTINE

M1 **M2** **M3** **M4** **M5** **M6** **M7** **M8** **M9** **M10**

ADVANCED MEDITERRANEAN PRO-AGEING SOLUTIONS

The Mediterranean diet has been inscribed among Intangible Cultural Heritage of Humanity since 2010, in recognition of its correlation with a better and longer quality of life. In motivating UNESCO's decision, which was reached after decades of scientific evidence and years of candidacy, the United Nations emphasized, above all, the understanding of the concept of "staying" in the term diet. The UN underlined the fact that, although many dietary choices are intrinsically health-related, this alone is not sufficient: the Mediterranean "diet" is not simply what one eats but a way of understanding life as a whole: it is a collection of virtuous behaviors and habits that regulate our daily rhythms and rituals.

This prestigious recognition by UNESCO rewarded the entire Mediterranean region, especially Italy, which is renowned throughout the world as an example of balance between diet, conviviality and lifestyle. It is, therefore, no coincidence that here in Italy the partnership among four important companies specializing in the production of plant active ingredients - **Orveda, Osmo Solutions, Maylea, Evra, and Invi Italia** - has resulted in today's launch of **FRAME® Advanced Mediterranean Pro-Ageing Solutions**. It is the first complete range of products and services for wellbeing, longevity, and beauty devised to embrace the challenge set by UNESCO's recognition and respond to the complexities it entails. The name **FRAME®** evokes the roots and composite identity of the brand, founded in order to merge the history and expertise of companies boasting over twenty years of technical and scientific experience with a new, positive approach to the culture of ageing, which encompasses the Mediterranean spirit.

framecosmetics.com

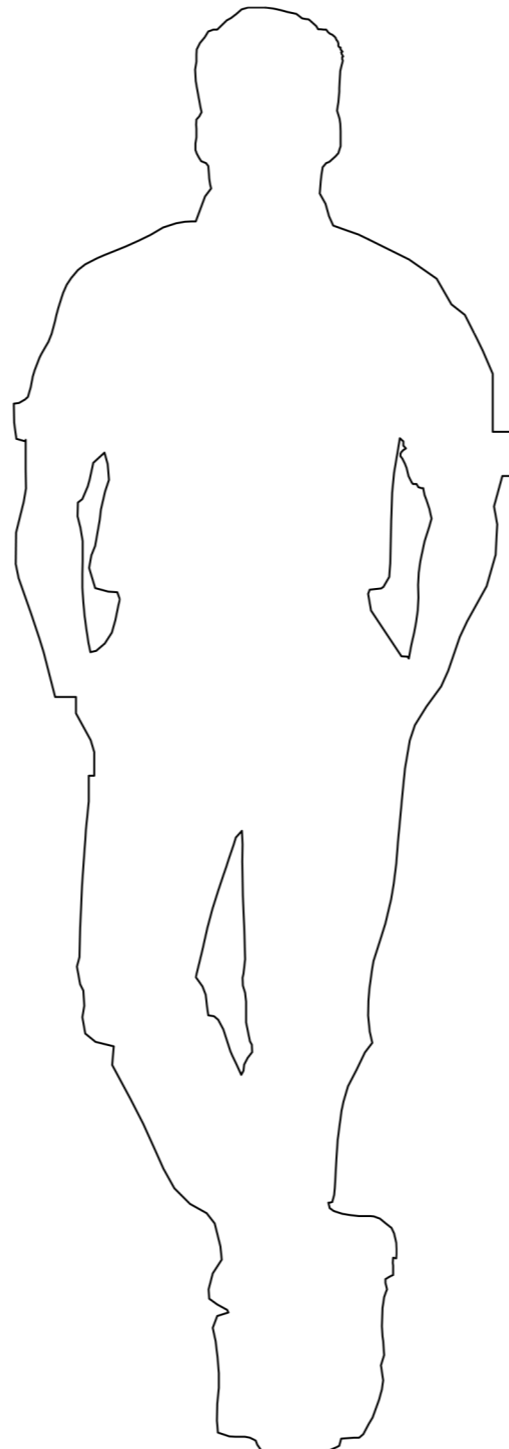

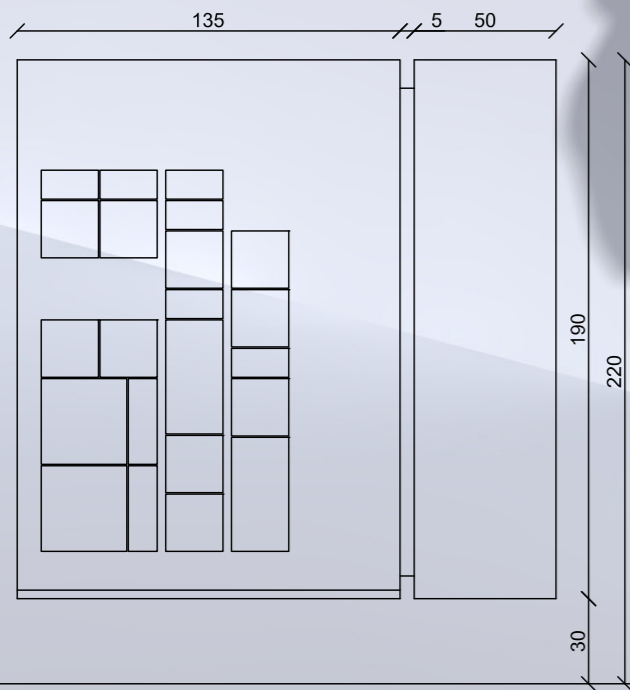
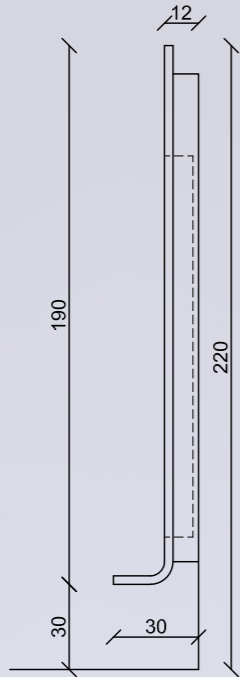

FRAME ADVANCED MEDITERRANEAN PRO-AGEING SOLUTIONS

The Mediterranean diet has been inscribed among Intangible Cultural Heritage of Humanity since 2010, in recognition of its correlation with a better and longer quality of life. In motivating UNESCO's decision, which was reached after decades of scientific evidence and years of candidacy, the United Nations emphasized, above all, the understanding of the concept of 'lifestyle' in the term diet. The UN underlined the fact that, although many dietary choices are intrinsically health-related, this alone is not sufficient: the Mediterranean 'diet' is not simply what one eats but a way of understanding life as a whole; it is a collection of virtuous behaviors and habits that regulate our daily rhythms and rituals. This prestigious recognition by UNESCO rewarded the entire Mediterranean region, especially Italy, which is renowned throughout the world as an example of balance between diet, conviviality and lifestyle. It is, therefore, no coincidence that here in Italy the partnership among four important companies specializing in the production of plant active ingredients - **Bebe, Osun Solutions, Maylea, Evva, and Nvh Italia** - has resulted in today's launch of **FRAME® Advanced Mediterranean Pro-Ageing Solutions**. It is the first complete range of products and services for wellbeing, longevity, and beauty devised to embrace the challenge set by UNESCO's recognition and respond to the complexities it entails. The name **FRAME®** evokes the roots and composite identity of the brand, founded in order to merge the history and expertise of companies boasting over twenty years of technical and scientific experience with a new, positive approach to the culture of ageing, which encompasses the Mediterranean spirit.

framecosmetics.com

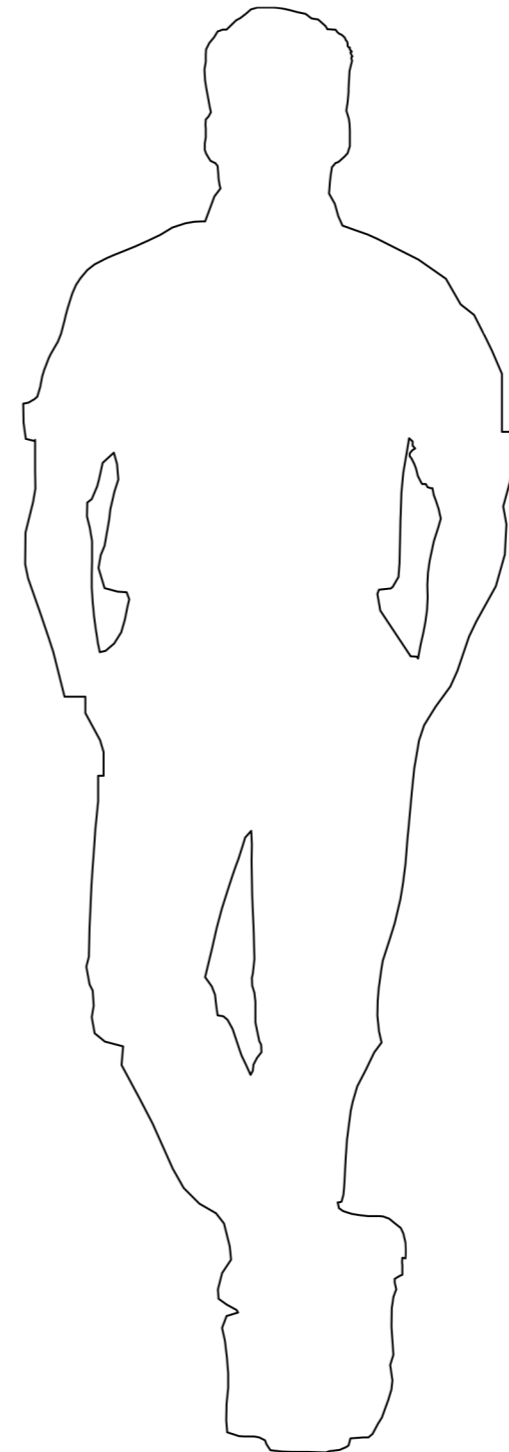

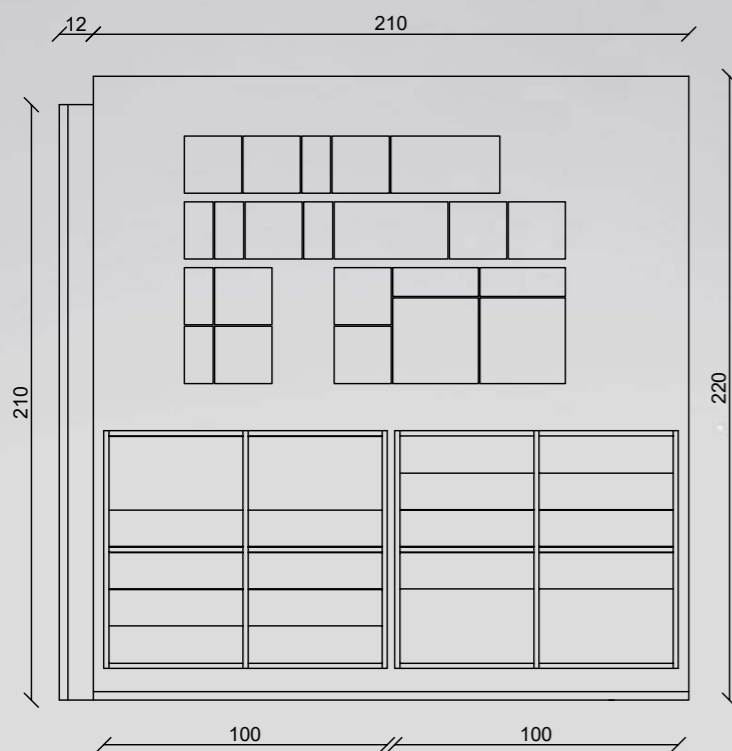
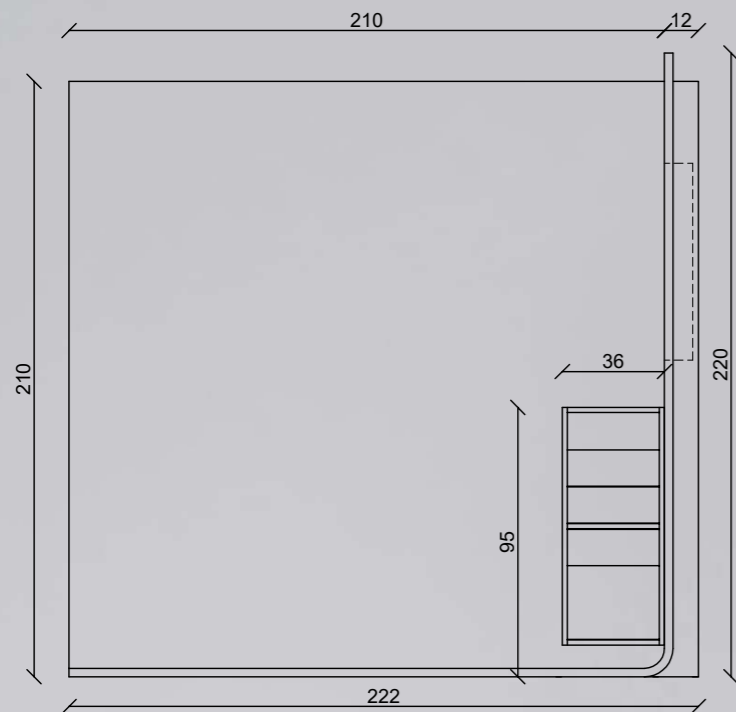

misula

WE ARE DEDICATED TO PROVIDING OUR CUSTOMERS WITH ONLY TOP-TIER PRODUCTS, BASED ON THE MOST CURRENT SCIENTIFIC KNOWLEDGE. **OURS IS A FRESH APPROACH TO LUXURY SKINCARE: WHEN USING MEDITERRANEAN BOTANICAL INGREDIENTS IN THEIR PUREST FORM LEVERAGING THE POWER OF NATURE WITHIN THE CONTEXT OF SCIENCE AND OFFERING PRODUCTS THAT ARE NOT ONLY GOOD FOR YOUR SKIN, BUT ALSO GOOD FOR OUR PLANET.**

FRAMECOSMETICS.COM FRAMECOSMETICS.COM

FRAME ADVANCED MEDITERRANEAN PRO-AGEING SOLUTIONS

The Mediterranean has long been a source of inspiration for luxury skincare. Its rich history of botanical ingredients and scientific knowledge has inspired a new generation of luxury skincare products. **FRAME** Advanced Mediterranean Pro-Ageing Solutions are the result of this inspiration. They are formulated with the most current scientific knowledge and the finest botanical ingredients to provide you with the ultimate anti-ageing experience. **FRAME** Advanced Mediterranean Pro-Ageing Solutions are the result of this inspiration. They are formulated with the most current scientific knowledge and the finest botanical ingredients to provide you with the ultimate anti-ageing experience.

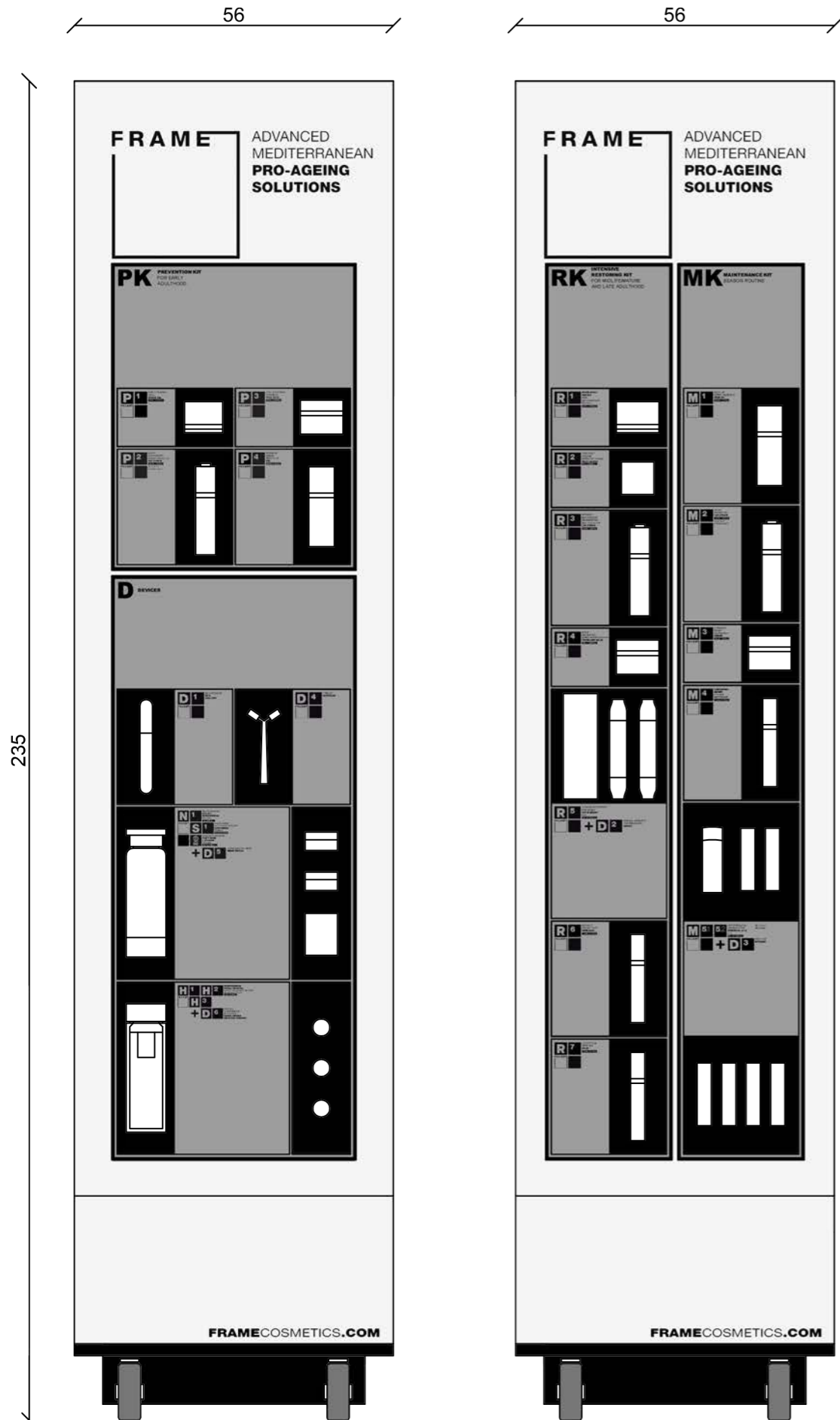

STAND ALONE

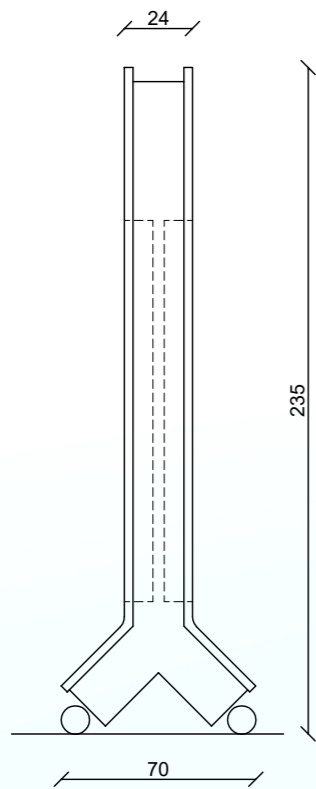
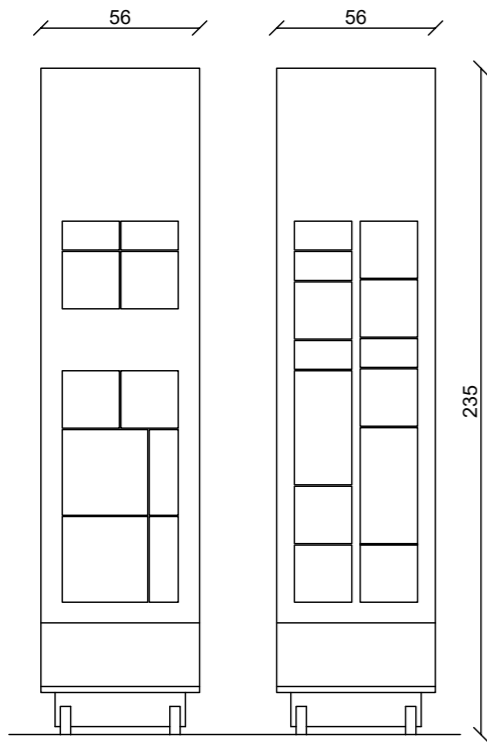

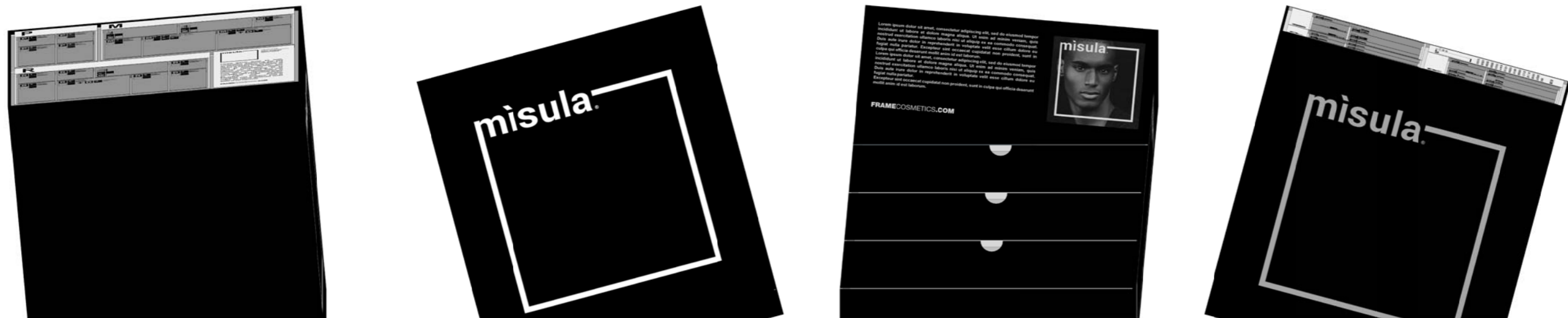
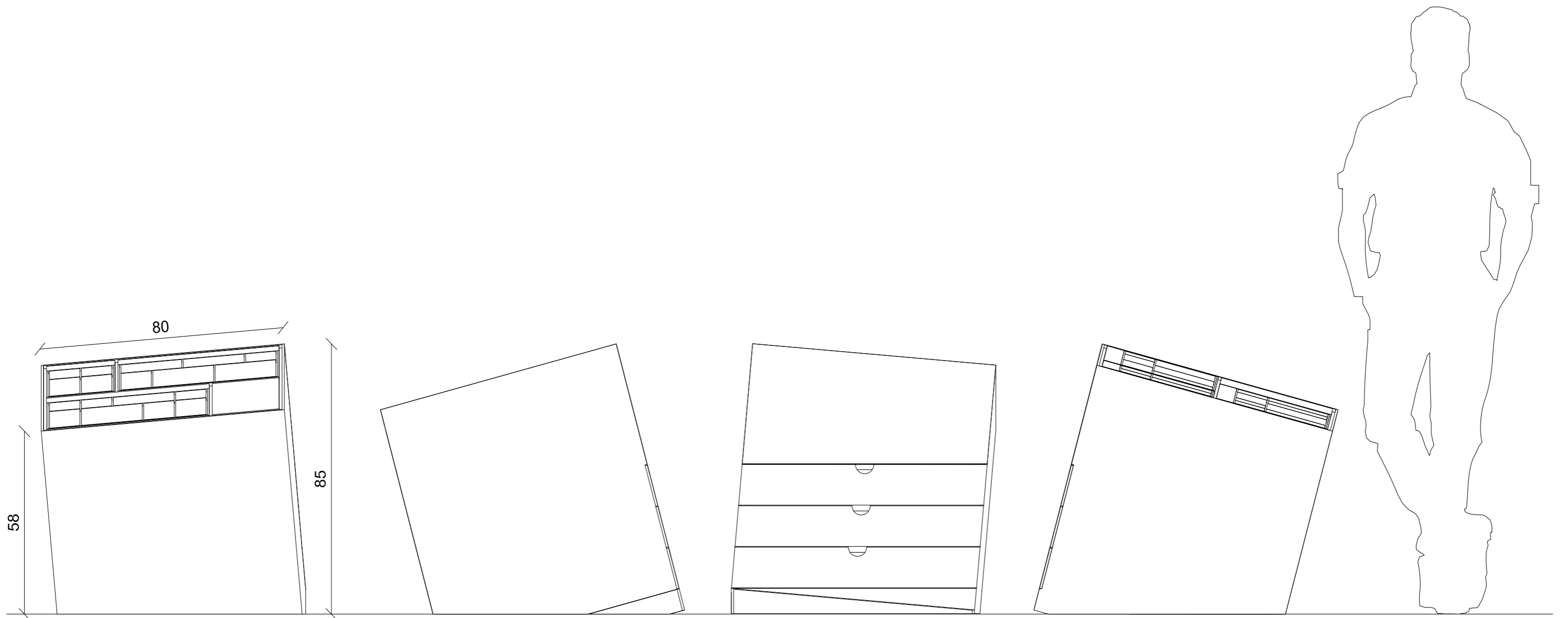

BOX

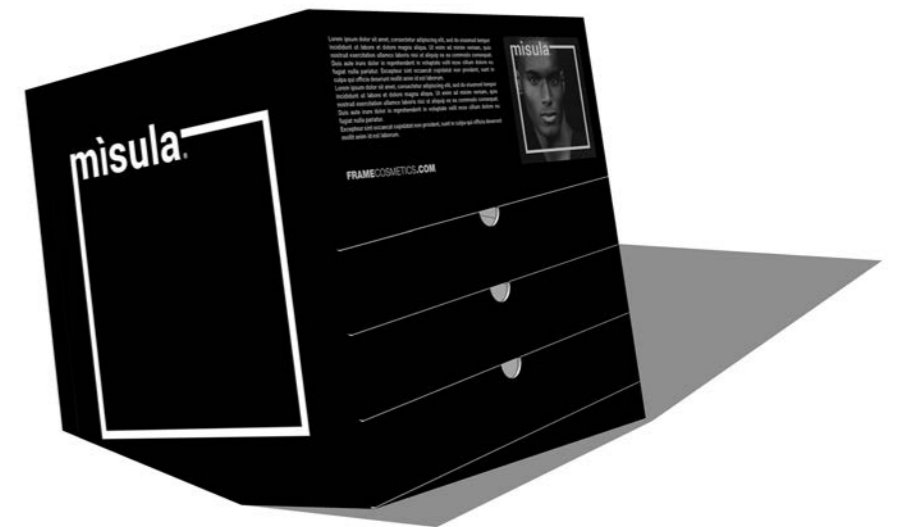
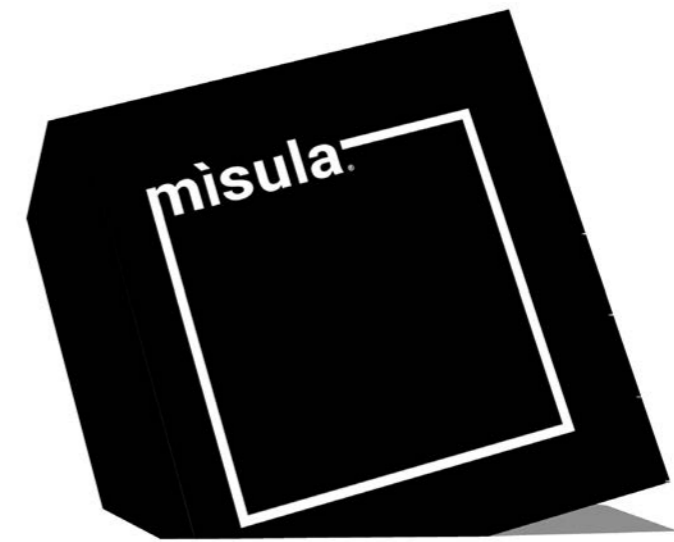
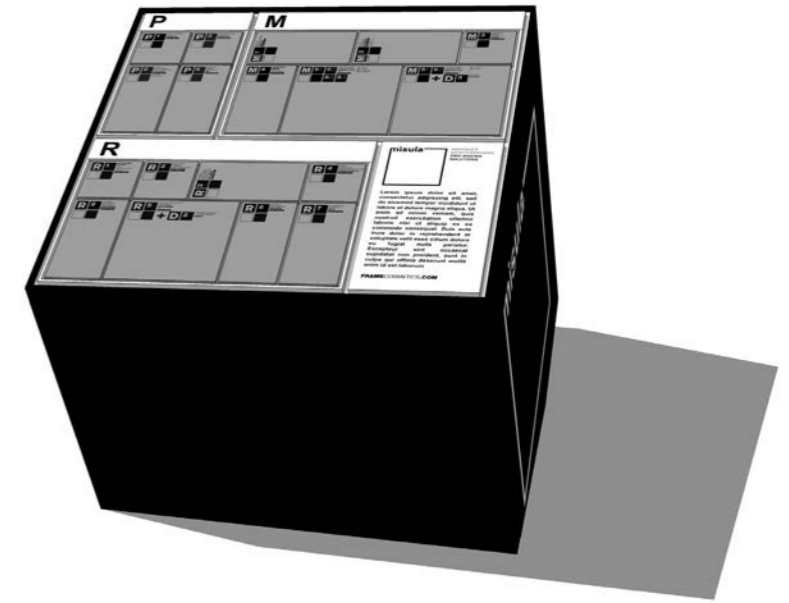
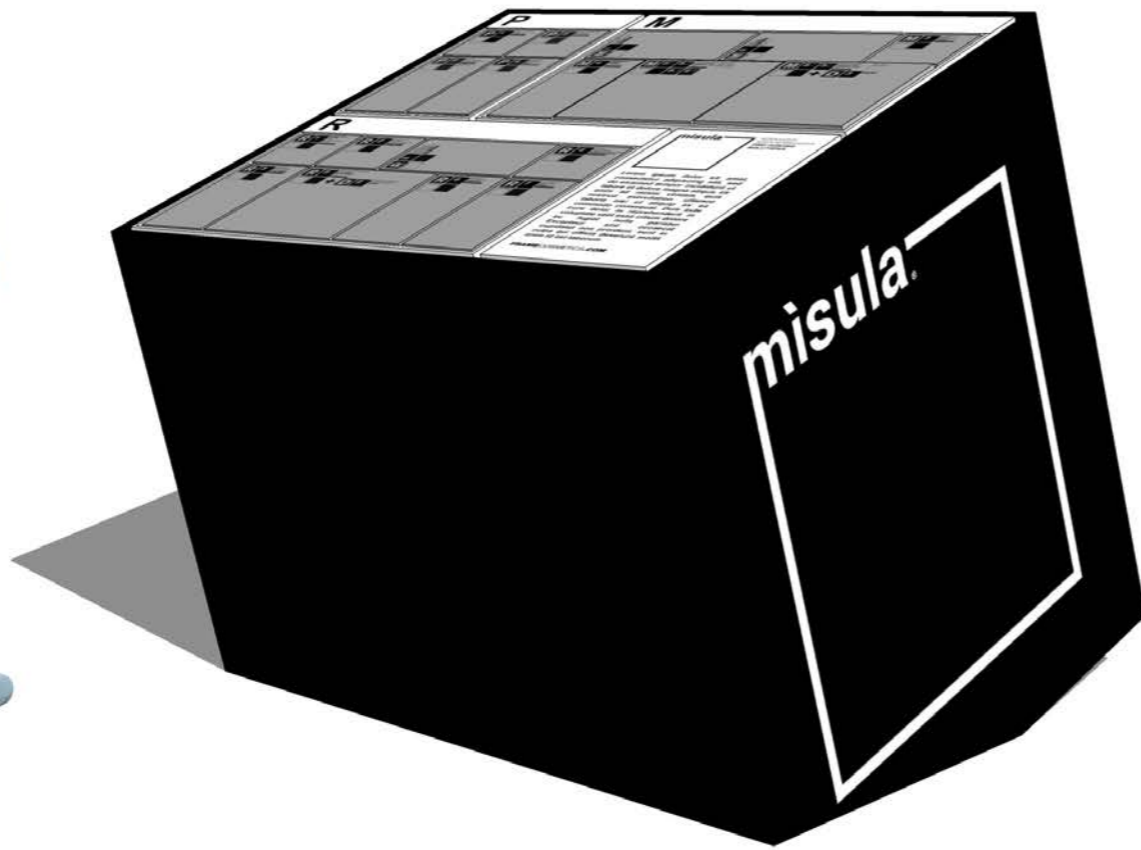

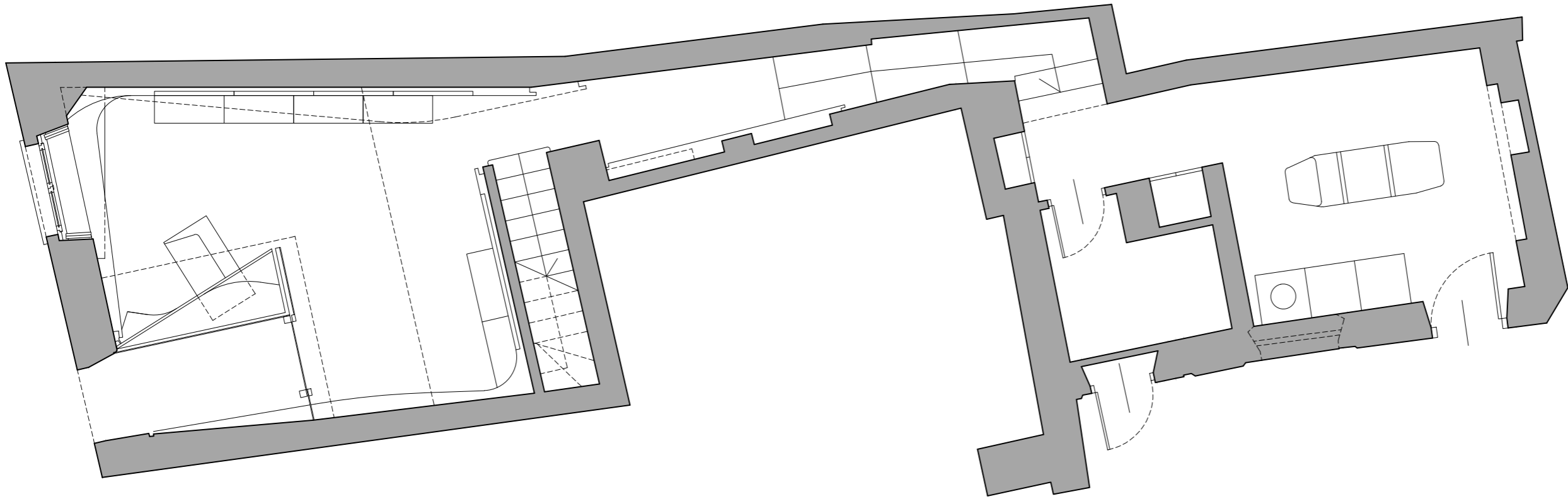

FLAGSHIP STORE

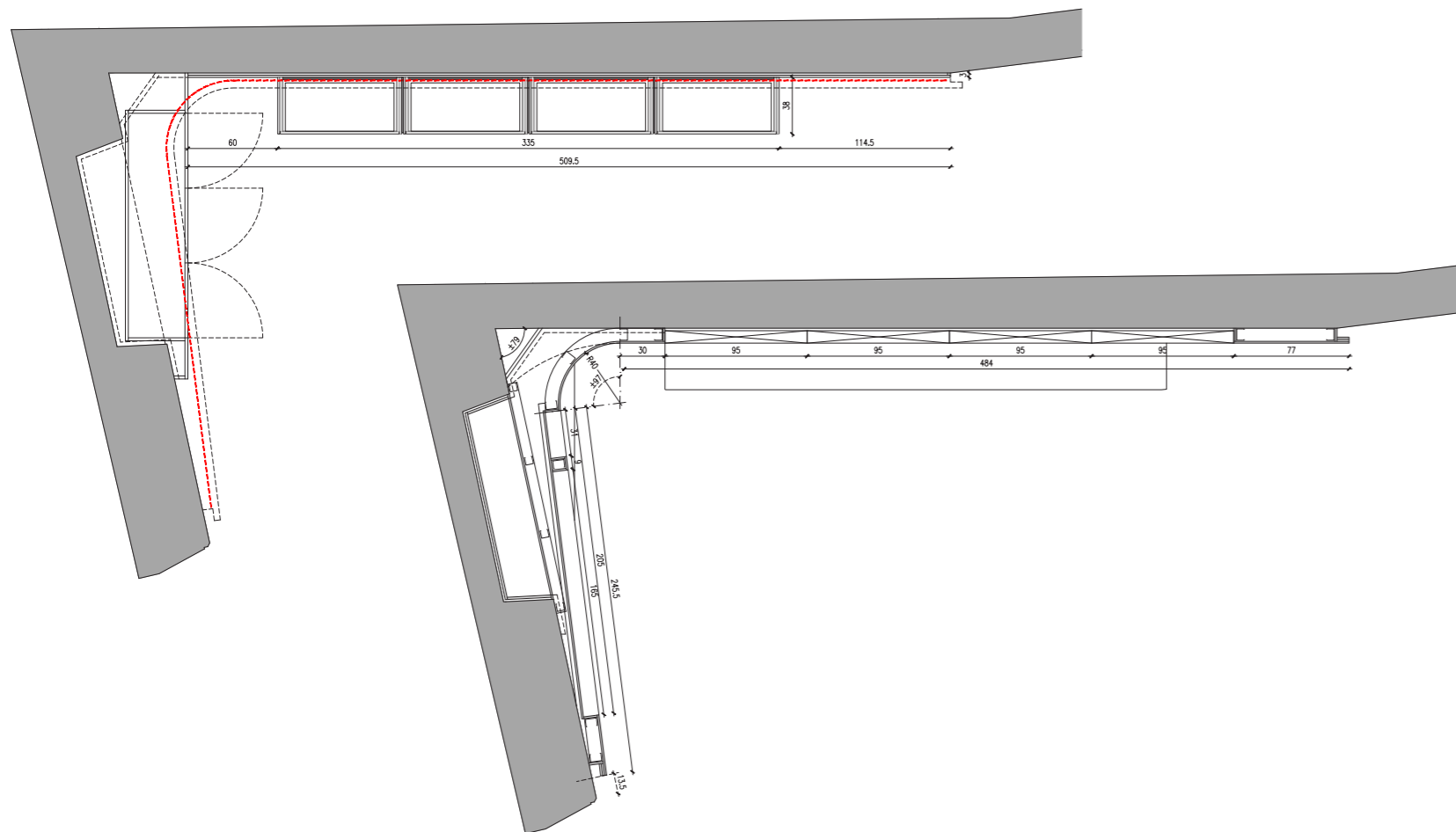
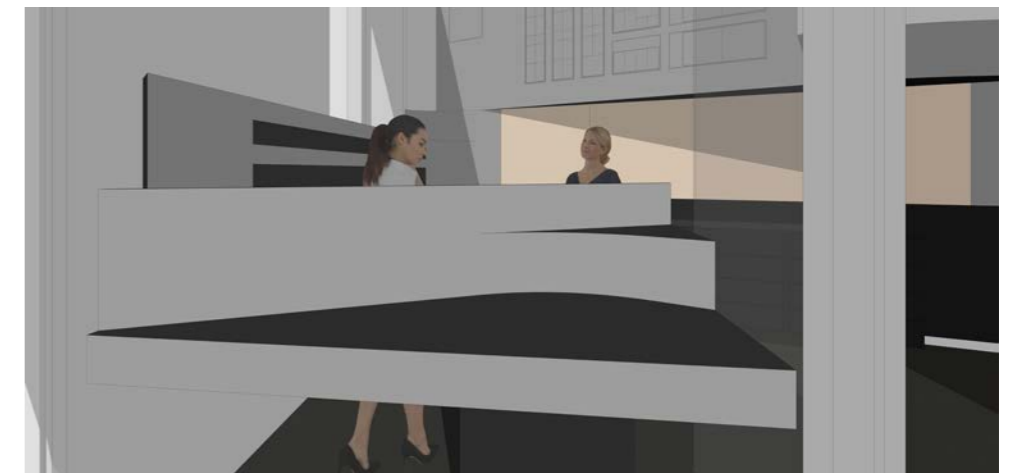
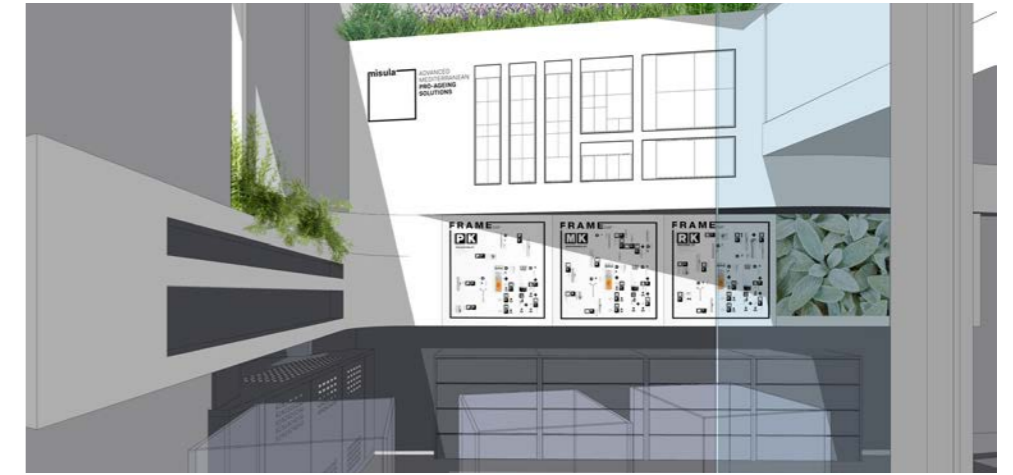
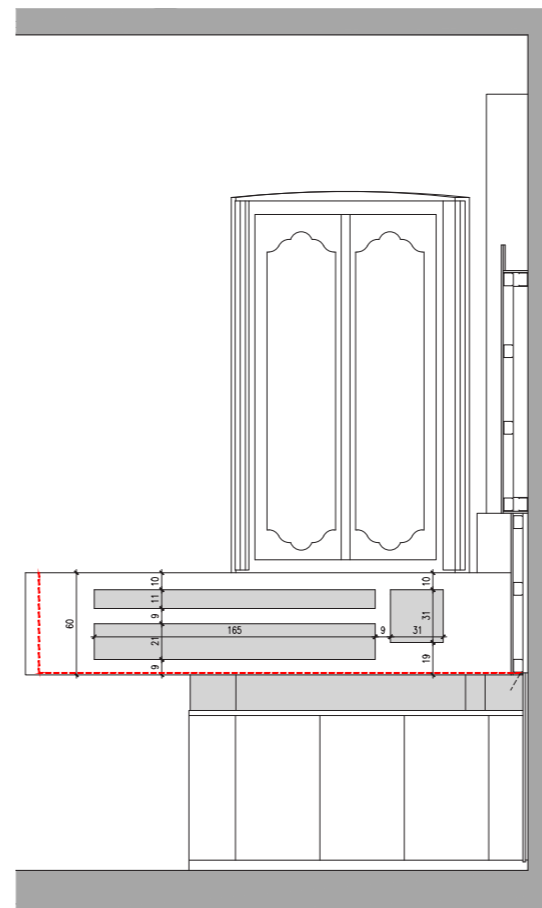
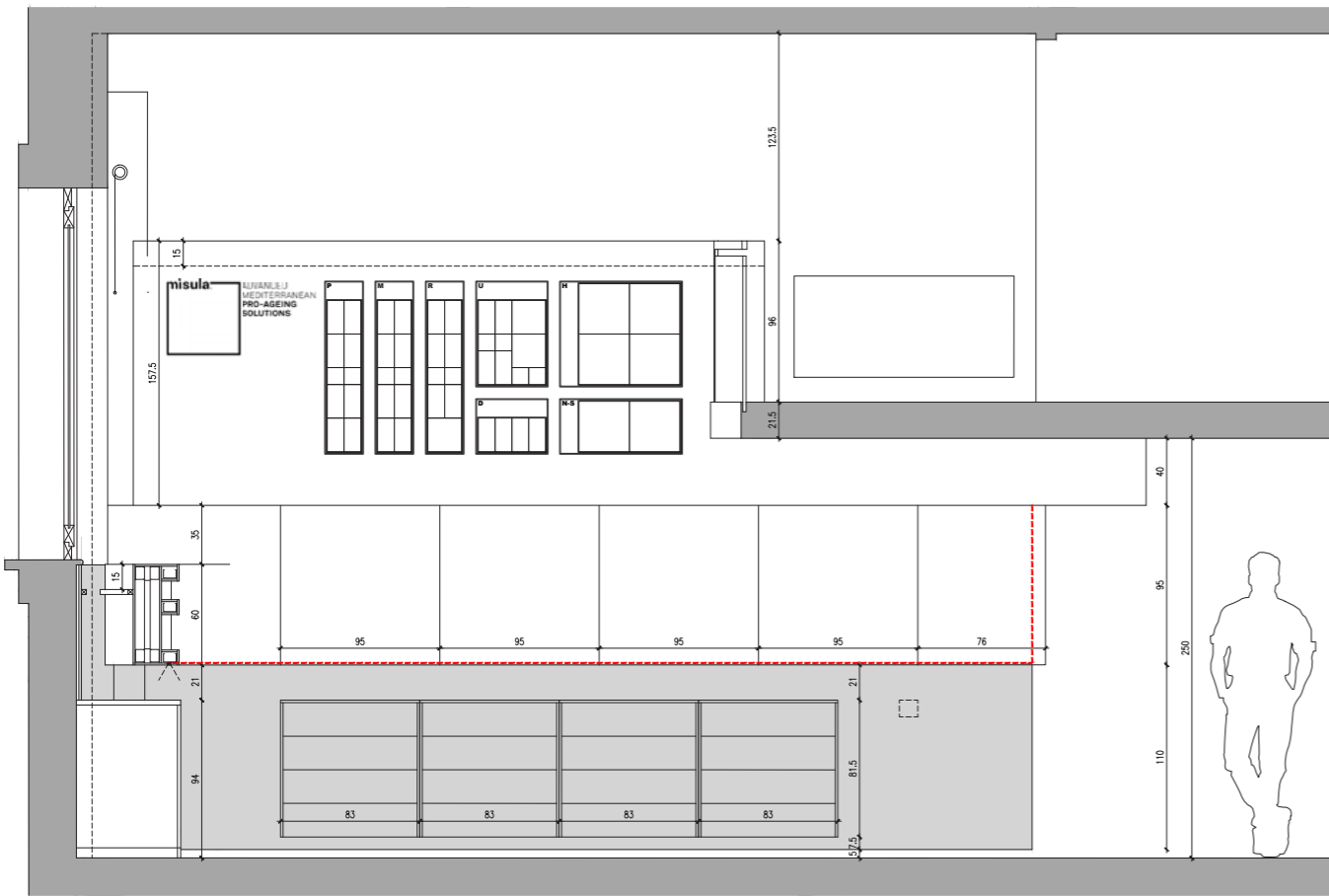

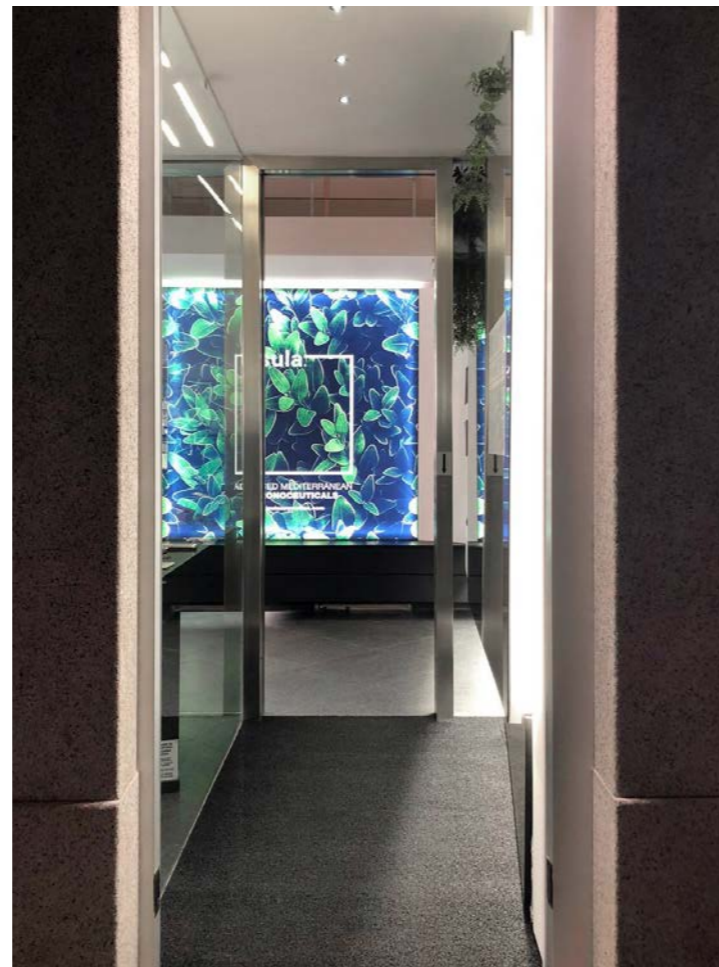

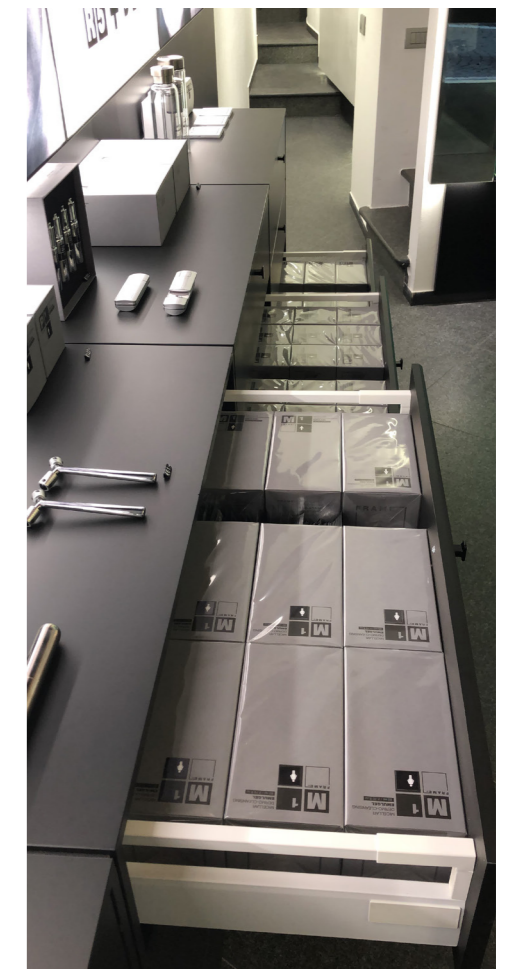
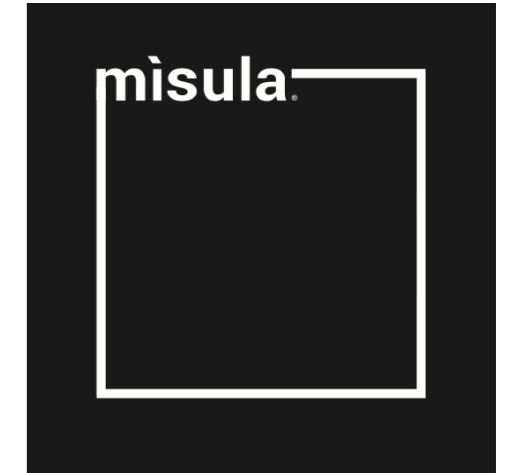
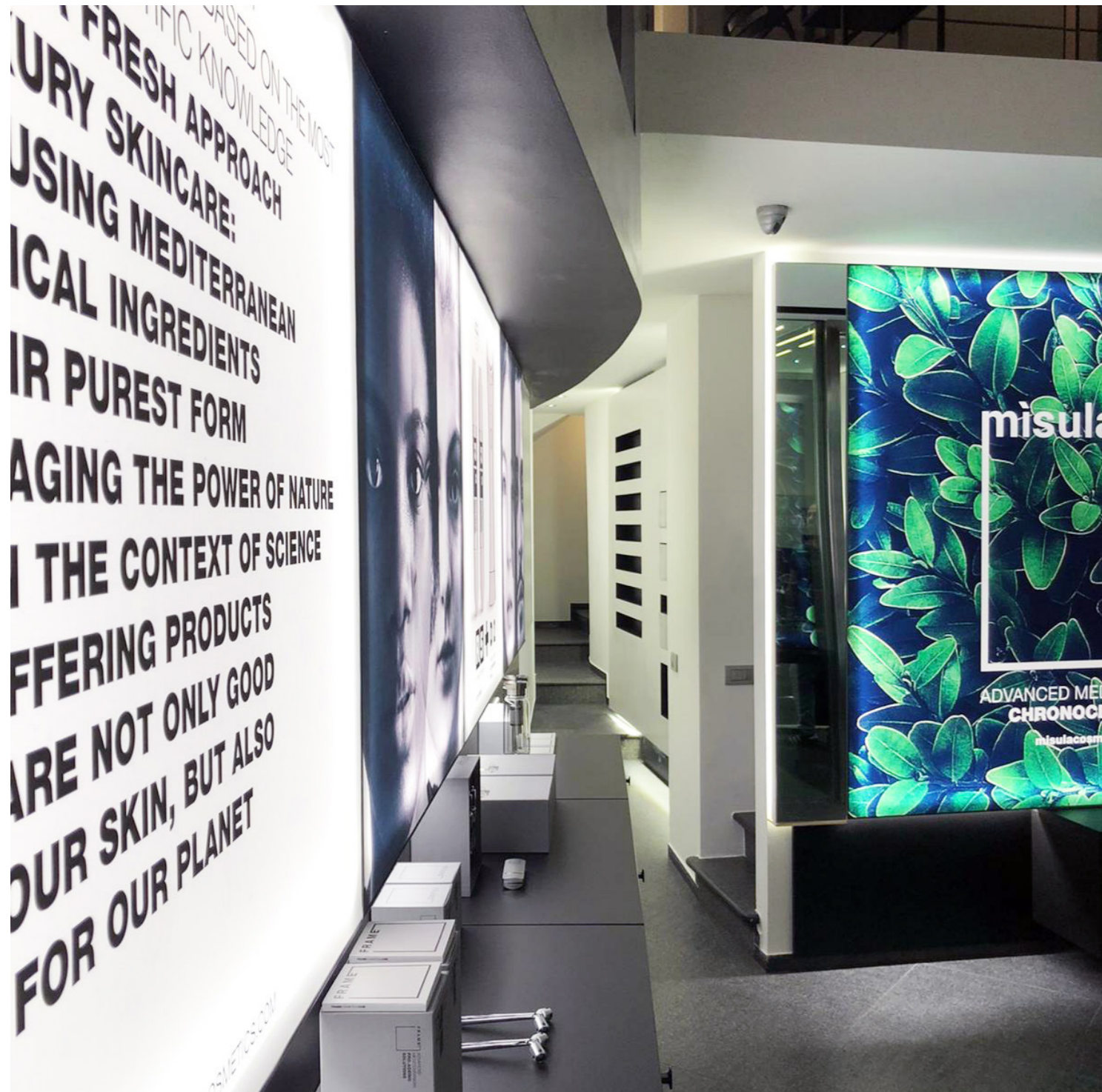

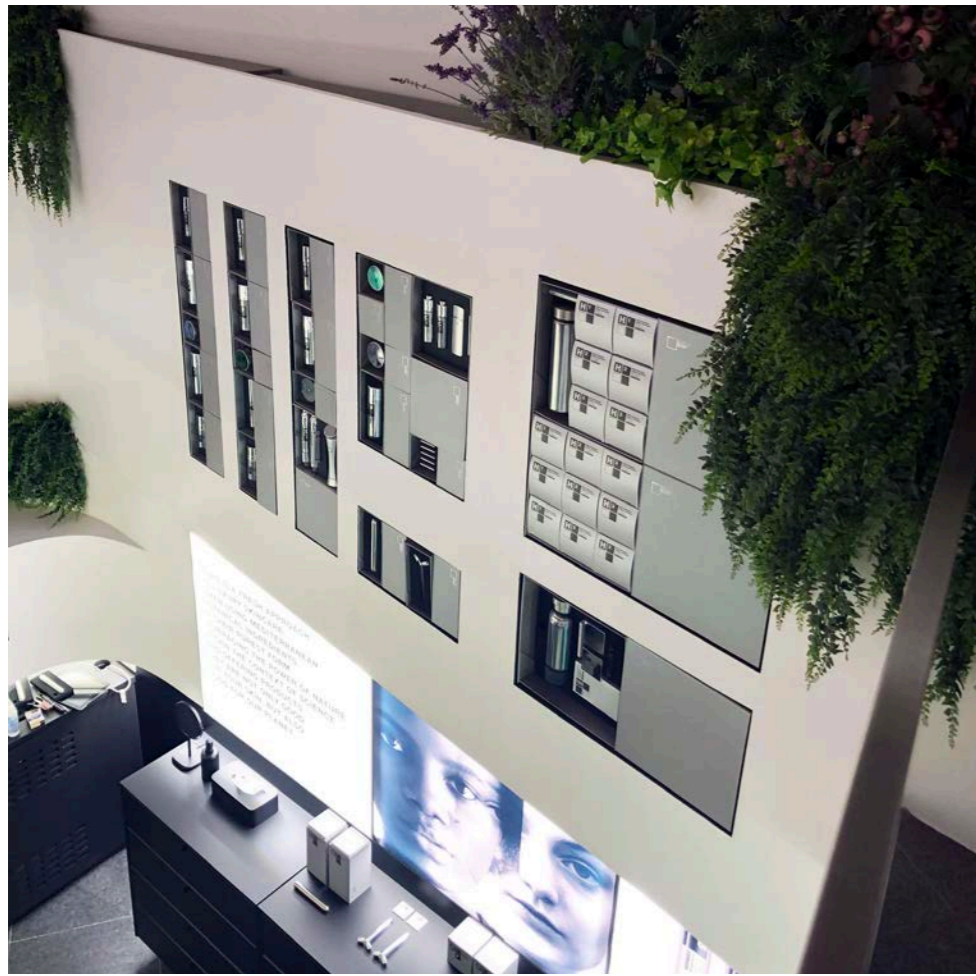

arch. ugo tranquillini

via san daniele 29 | 33100 udine

+39 347 0481614

archugotranquillini@yahoo.it