



INSTALLATION INSTRUCTIONS

for

#10617 Fuel Rail Kit

3

Use this kit with the following Pro/Products Intake Manifolds:

52053 - 52054 - 52055 - 52083 - 52084 - 52085

(Also fits Holley #300-136 & #300-137 manifolds)

For LS1, LS2, LS3, LS6 & L92

Kit Contents:	(4) Long Screws
(2) Fuel Rails	(8) Small O-Rings
(4) Short LS1 Mtg Brackets	(4) Large O-Rings
(4) Short LS3 Mgt Brackets	(3) -08 AN Fittings
(4) Tall LS1 Mounting Brackets	(1) AN Plug
(4) Tall LS3 Mounting Brackets	(1) Crossover Hose Assy.
(4) Short Screws	(1) Instruction Sheet

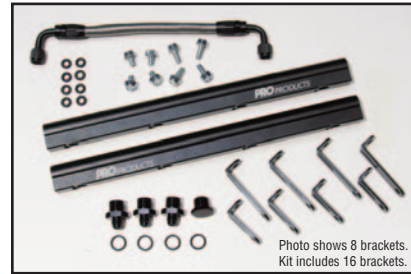

This Fuel Rail Kit is designed to work with two different types of injectors. The tall brackets are used with EV-1 (LS1) style of injectors. The shorter brackets will work with LS3 or LS7 injectors but if used on either the LS1 or LS3 manifold the injectors need to use the small supplied o-rings on the end that goes into the fuel rails. The (5) large o-rings are used on the AN style fittings. You may not need all four of the AN fittings depending upon how you plumb your fuel system. In that instance, you will need to use the plug.

Assembly Procedure

1. Bolt your choice of mounting brackets in the four corner positions. LS1 Brackets are stamped with "1." LS3 Brackets are stamped with "3." Use the longer of the two sets of screws. Do not tight down the screws.
2. Lubricate o-rings on both ends of injectors.

3. Insert injectors into manifold.
4. Thread the AN fittings with large o-rings installed into the ends of the fuel rails. Note both rails are the same. Make sure the tapped mounting bolt holes are facing in on both rails.
5. Press fuel rails onto the top of the injectors. Light oil or WD-40 on the o-rings will ease assembly.
6. Align threaded holes in the rails with the four mounting brackets.
7. Thread the four short bolts through the brackets and into the fuel rails. Snug those bolts and then tighten all the bolts holding the mounting brackets to fuel rails and the manifold. Tighten all bolts to approximately 4-5 pound feet of torque.
8. Attach crossover hose to fuel rails. Tighten with an 7/8" open end wrench. Check for leaks.

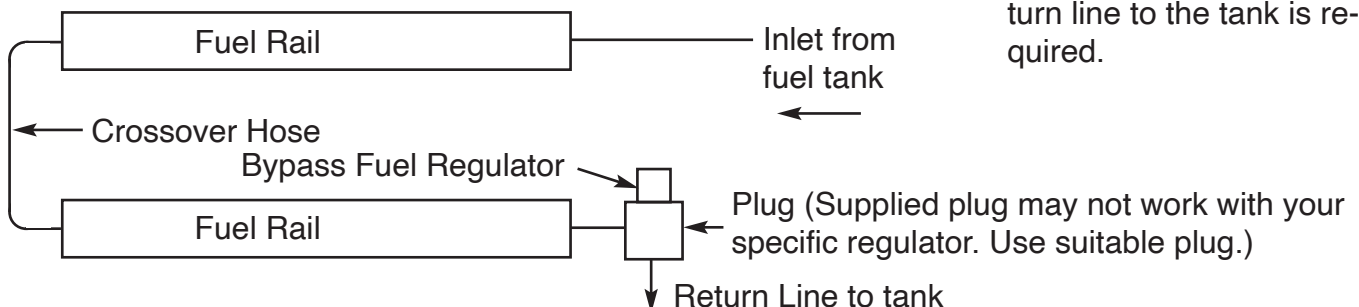
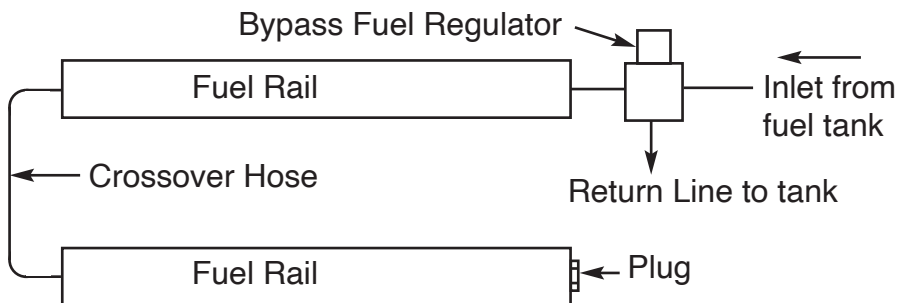

At left are shown two alternative ways to plumb your fuel rails. A bypass style regulator with a return line to the tank is required.