

Universal PRO Call Blocker with LCD Display & Blacklist Memory

User's Manual (Revised by HQTELECOM) Model CT-CID 803



This modern and eco-friendly incoming *phone call blocker* has been designed for avoiding the disturbances coming from incoming calls. It can block ringing of up to 1,500 phone numbers that you do not want to answer.

Features:

- FSK/DTMF dual system compatible CID
- Stores up to 1,500 phone numbers in the “Black list”
- Line Powered — does not require any external power supply
- EEPROM technology prevents losing stored numbers when disconnected from the telephone line.
- Stores up to 100 sets of income phone numbers and 50 sets outgoing phone numbers
- LCD display has 4 levels of brightness
- Lock and un-lock function

Installation:

As shown below, there are 2 options available to install your call blocker. We recommend you try option 1 first. If you run into any issues e.g. unable to display caller id on existing phones, then use option 2.

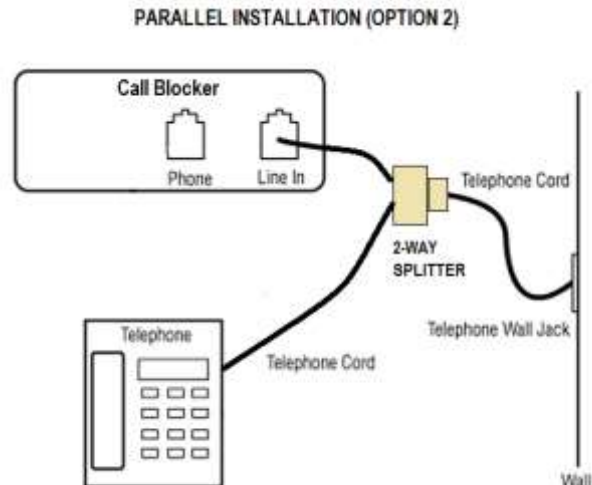
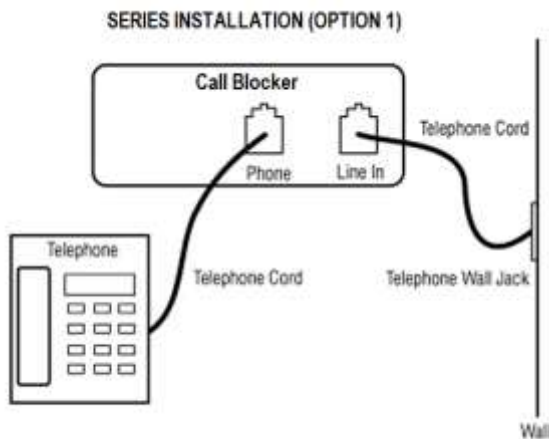

Operation:

1. Setting Date and Time

If you have the CallerID feature enable on your phone line, the date/time will be automatically set when a phone call come in. So, there is no need to set the date/time, except for the year (which is set to 2011 as default).

Follow these instructions if you do not have CallerID on your telephone line:

Press the “**SET**” key, the LCD displays setting items, then press “<” or “>” keys for selecting corresponding item. During this setting, you can press the REMOVE key to return to previous menu item. The LCD will display the week and calendar according to setting of the time and date.

2. LCD Brightness Setting

Press the “**SET**” key, the LCD displays setting items, then press “<” or “>” keys for selecting corresponding item. Then press “<” or “>” keys again to change the LCD brightness levels. There are four (4) levels of brightness. Press the **SET** key to confirm. After setting, briefly press the **REMOVE** key to exit this setting.

Warning: If you press and hold the **REMOVE** key for 3 seconds or more, all incoming numbers, outgoing numbers, and numbers stored in the blacklist will be deleted, and will display NO CODE when finished.

3. Checking incoming phone numbers

Press the “<” or “>” keys for up-page and down-page checking of incoming calls. The LCD will display the incoming numbers, time and date. It will display NO CODE if there are no incoming calls registered.

4. Checking the outgoing dialed numbers

Press **OUT** key to then press the “<” or “>” keys for up-page and down-page checking of the outgoing calls. The LCD will display the outgoing numbers, time and date. A maximum of 16 digits of the numbers dialed will be stored and displayed. If the caller dialed more than 16 digits, the unit will only store and display the last 16 digits. It will display NO CODE if there are no outgoing calls.

5. REMOVE

When displaying an incoming, outgoing, or blacklist number, press the **REMOVE** key to delete the displaying number. **Warning:** If you press and hold the **REMOVE** key for 3 seconds or more, all incoming numbers, outgoing numbers, and numbers stored in the blacklist will be deleted, and will display NO CODE when finished.

6. BLACKLIST

When checking the incoming or outgoing phone numbers, press **BLACKLIST** key on displaying number to add into the blacklist. If successful, the display will display SAVE and SUCCEED. If the number was already added to the blacklist, it will display REP.

If you wish to add a number that is not shown in the Caller ID, simply enter the number using the dialpad of the telephone unit connected to the Blocker and press the **BLACKLIST** key.

Blacklist Operation: When a telephone number is in the Blacklist, the incoming calls will be blocked automatically. The blocker device will pick up and then disconnect the call (go off hook) after 1 second. The caller will hear one ring and then silence.

Please visit www.HQTelecom.com if you have any questions or need help with this device.
