

# VELKA 5

## Rev 3.0

# USER MANUAL

6/OCT/23

SPECIFICATION .....	2
HARDWARE COMPATIBILITY .....	3
PACKAGE CONTENTS .....	5
REQUIRED TOOLS .....	5
CASE DISASSEMBLY .....	6
MOTHERBOARD .....	7
PCIE RISER CABLE .....	8
GRAPHICS CARD .....	9
MOTHERBOARD TRAY INSERTION .....	13
PSU .....	14
CASE FANS .....	15
DEDICATED SATA DRIVE .....	16
ADDITIONAL SATA DRIVES .....	17
CLOSING THE CASE, STAND, RUBBER FOOT INSTALLATION ..	18
TROUBLESHOOTING .....	18
SUPPORT AND SERVICE .....	19

## SPECIFICATION

	Without stand	With stand
Dimensions (L x W x H)	178 x 102 x 283 mm 7.0 x 4.0 x 11.1 in	178 x 102 x 327 mm 7.0 x 4.0 x 12.9 in
Weight	1.7 kg 3.7 lb	1.9 kg 4.2 lb
Volume	5.14 L external; 4.92 L internal	5.94 L external; 5.69 L internal
Materials	<p>Main body: 1.2 mm galvanized steel, powdercoated, stainless threaded inserts</p> <p>Front panel: 2.0 mm galvanized steel, powdercoated, stainless threaded inserts</p> <p>Side panels, stand, interior brackets: 1.0 mm galvanized steel, powdercoated, stainless threaded inserts</p> <p>Structural standoffs: Brass</p> <p>Screws: Ferrous steel</p> <p>Power button: Aluminum, anodized</p>	
I/O	<p>Front: N/A</p> <p>Bottom: Graphics card (if using the stand). May be routed to the rear using internal cable extensions (not included)</p> <p>Top: Graphics card (if not using the stand)</p> <p>Rear: Motherboard</p> <p>Note: the top 1 cm (typically 1 port) of the discrete graphics card IO is only accessible by internal extension cables if the graphics card is mounted in the forward offset position</p>	
Security	Kensington Lock Slot	



## HARDWARE COMPATIBILITY

Motherboard	<p>Mini ITX*</p> <p>170 x 170 mm</p> <p>*Maximum primary side component height: 47 mm</p>
Power supply	Flex ATX. Max length: 150 mm
CPU cooler	<p>Height:</p> <p>37 mm</p>
PCIe riser cable	<p>Required for graphics card or other PCI card support.</p> <p>Hole pitch: 108 mm</p> <p>Length: 29-35 cm end-to-end / 24-30 cm along flexible portion</p> <p>Connectors: 0° or 180° male to 0° or 180° female</p> <p>Recommended models: Velkase VC-S300G3 ; VC-S290G4</p>
Graphics card (L x W x H)	<p>Maximum clearance, including space for cables. Cables require 16 mm+ if not recessed and routed within the bounding box area of the board.</p> <p>270 x 43 x 143 mm 261 x 43 x 148 mm</p> <p>2.0 PCI slots thick Maximum backplate thickness: 6 mm</p> <p>2-slot graphics cards must not have protrusions past the edge of the PCI bracket</p>
Memory	<p>Height:</p> <p>42 mm</p>
Storage	<p>1x 2.5" HDD or SSD (7.0 mm thick)</p> <p>Additional storage for configurations with &lt; 200 mm long graphics cards: 3x 2.5" drives (7.0 mm thick) or 2x 2.5" drives (12.5 mm thick)</p>
Case fans	2x 40 mm fans, up to 30 mm thick

	30 mm hole spacing; mounting hardware not included
Handles	<p>Hole pitch: 128 mm</p> <p>Screw diameter: 4 mm maximum</p>
Internal display cable extensions	<p>Required only if routing graphics card output to the rear of the case and not using the stand.</p> <p>Hole pitch: 27 mm Screw diameter: 4 mm maximum</p> <p>Female connector clearance: 35 mm (45 mm with horizontal graphics card shift and 10 mm clearance reduction to graphics card height; requires VC-S290G4 PCIe riser cable or other 35 cm long PCIe cable)</p> <p>Male connector clearance: 11 mm (22-36 mm with vertical graphics card shift and equal graphics card length clearance reduction; requires VC-S290G4 PCIe riser cable or other 35 cm long PCIe cable)</p>
External display cables	60 mm maximum total protrusion from the graphics card when using the included stand with rubber feet

## PACKAGE CONTENTS

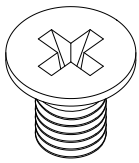
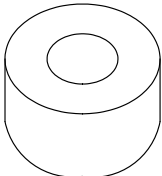
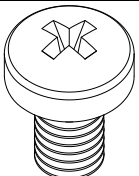
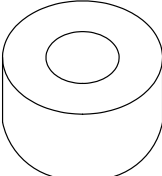
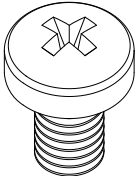
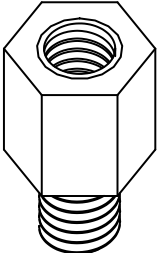
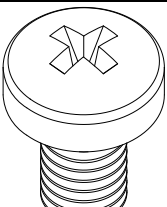
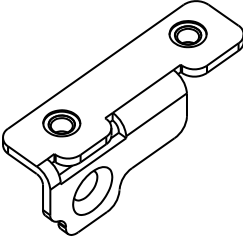
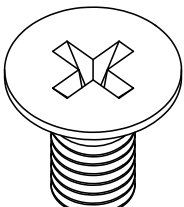
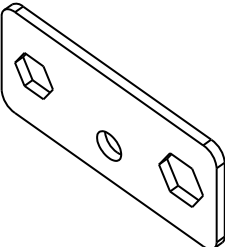
- Velka 5 chassis with pre-installed power button, stand. *PCIe riser cable, handle, and display cable extensions not included*
- 14x 3M Bumpon adhesive rubber bumpers
- Hardware box; contents listed below. Quantities may vary.

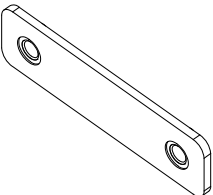
 x21	M3x0.5 5 mm countersunk screw	 x5	M3 3 mm spacer
 x27	M3x0.5 4 mm round head screw	 x6	M3 4 mm spacer
 x9	M3x0.5 10 mm round head screw	 x4	M3x0.5 standoffs (each): 5mm; 8 mm; 10 mm
 x6	6-32 6 mm round head screw	 x1	PCI card vertical offset bracket
 x12	M4x0.7 8 mm flat head screw	 x1	PCI card retention bracket
 x10	M3 1 mm spacer	 x4	Rear panel port cover

## REQUIRED TOOLS

#2 Phillips (PH2) screwdriver

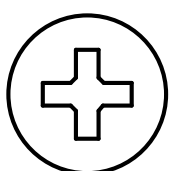

## CASE DISASSEMBLY

- Perform initial system assembly with all components and cables outside of the case
- Work on a soft, clean surface
- Once complete, disassemble the case to the following state

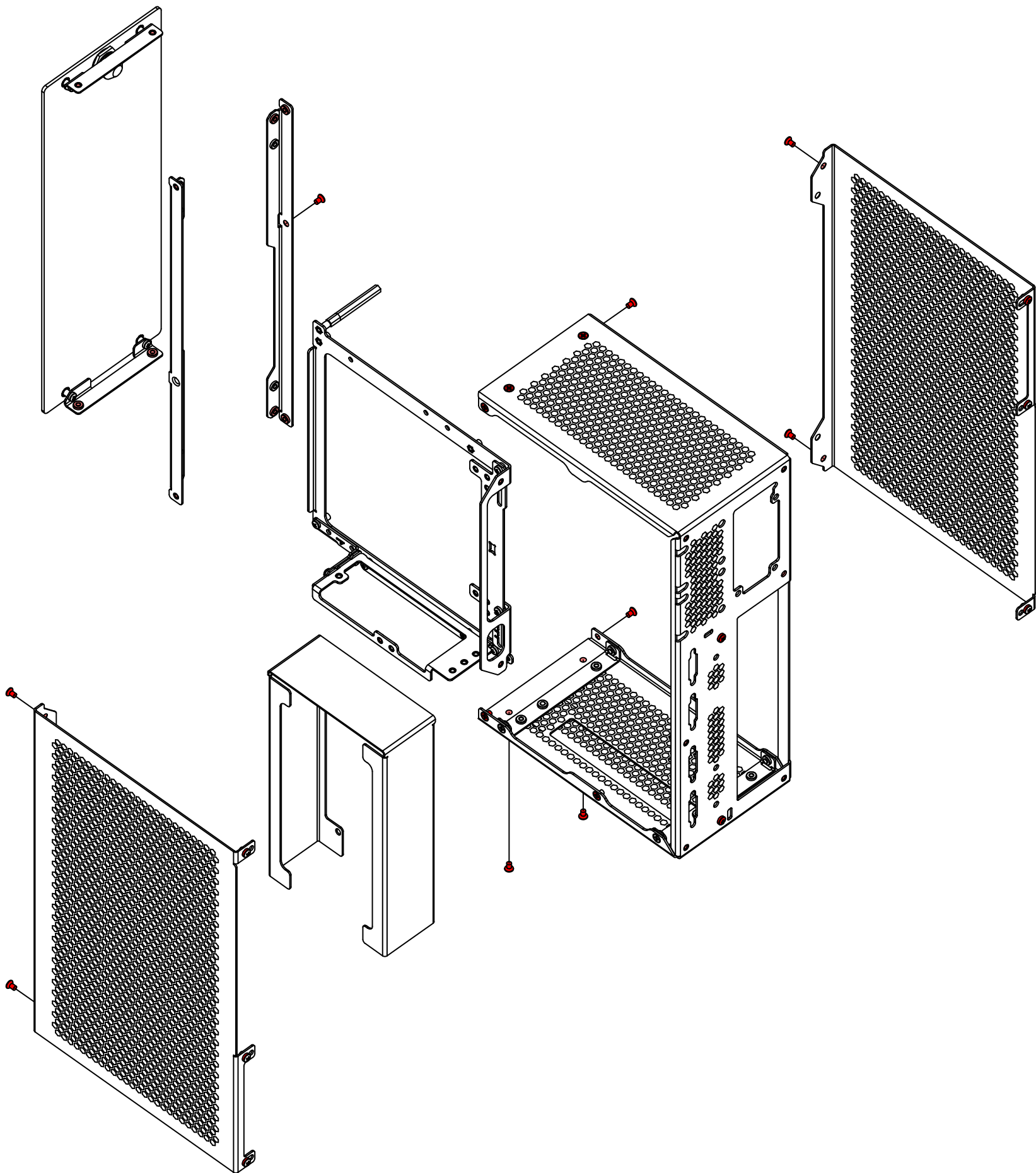

## MOTHERBOARD

- The CPU, CPU cooler, RAM, and storage should be installed onto the motherboard prior to this step.

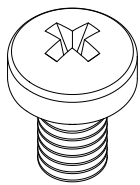

x4

M3x0.5 4 mm round head screw

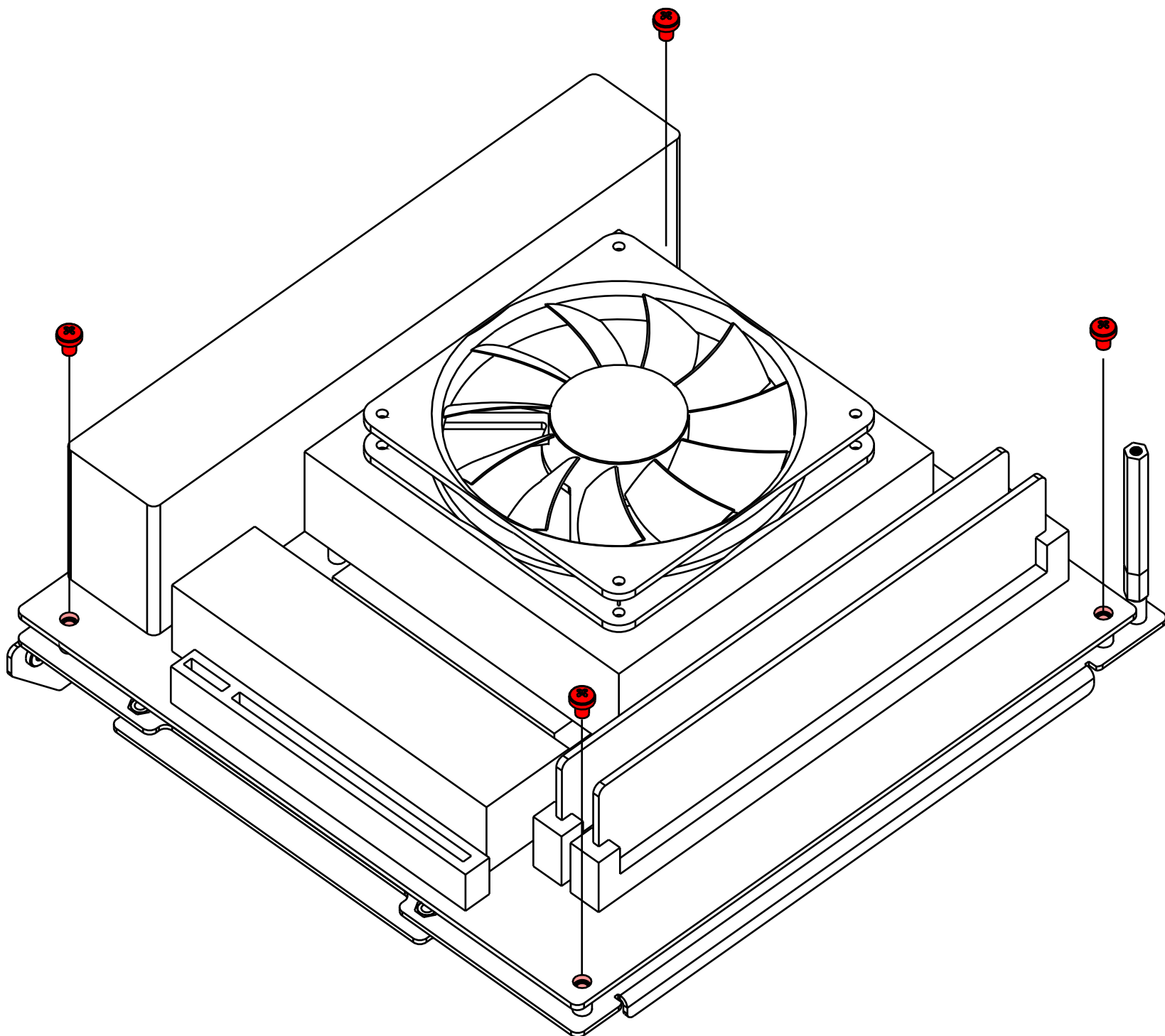

## PCIE RISER CABLE

- Bend the male and female ends 180 degrees
- Flat ribbon cables such as the VC-S300G3 require 2 additional diagonal folds to make a 90 degree turn
- Correctly sized spacers will closely match the bracket cutout

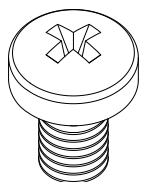

X2

M3x0.5 10 mm round head screw

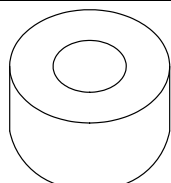

X2

M3 4 mm spacer

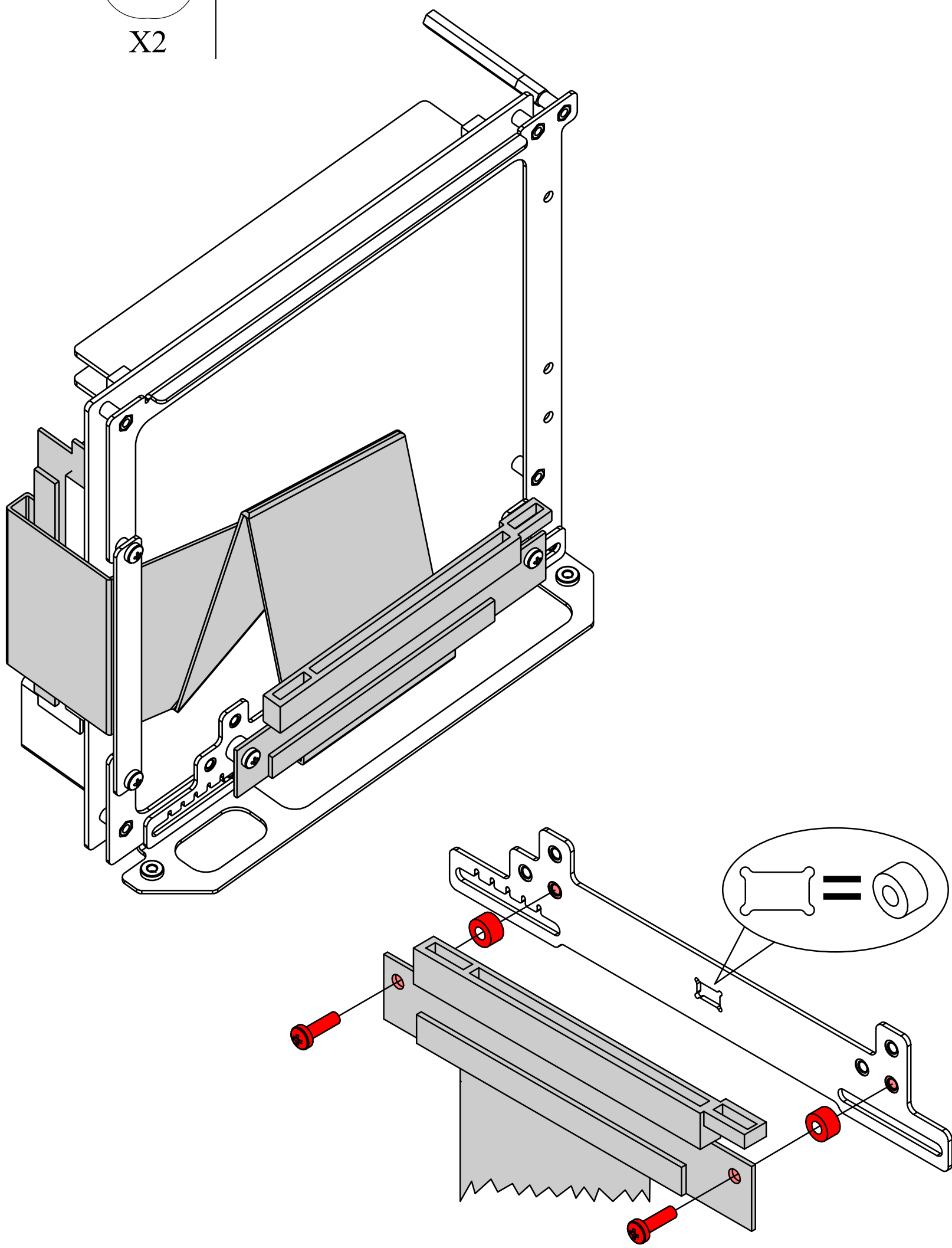



## GRAPHICS CARD

- Plug in internal display cable extensions after this step, if in use

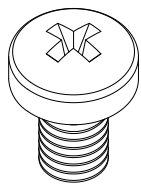

x4

M3x0.5 4 mm round head screw

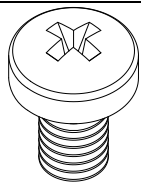

x1

M3x0.5 10 mm round head screw

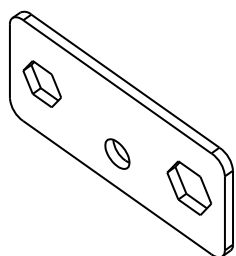

X1

PCIe card retention bracket

The arrow closest to the motherboard tray indicates the relative graphics card position. Flip to shift the card towards the case front

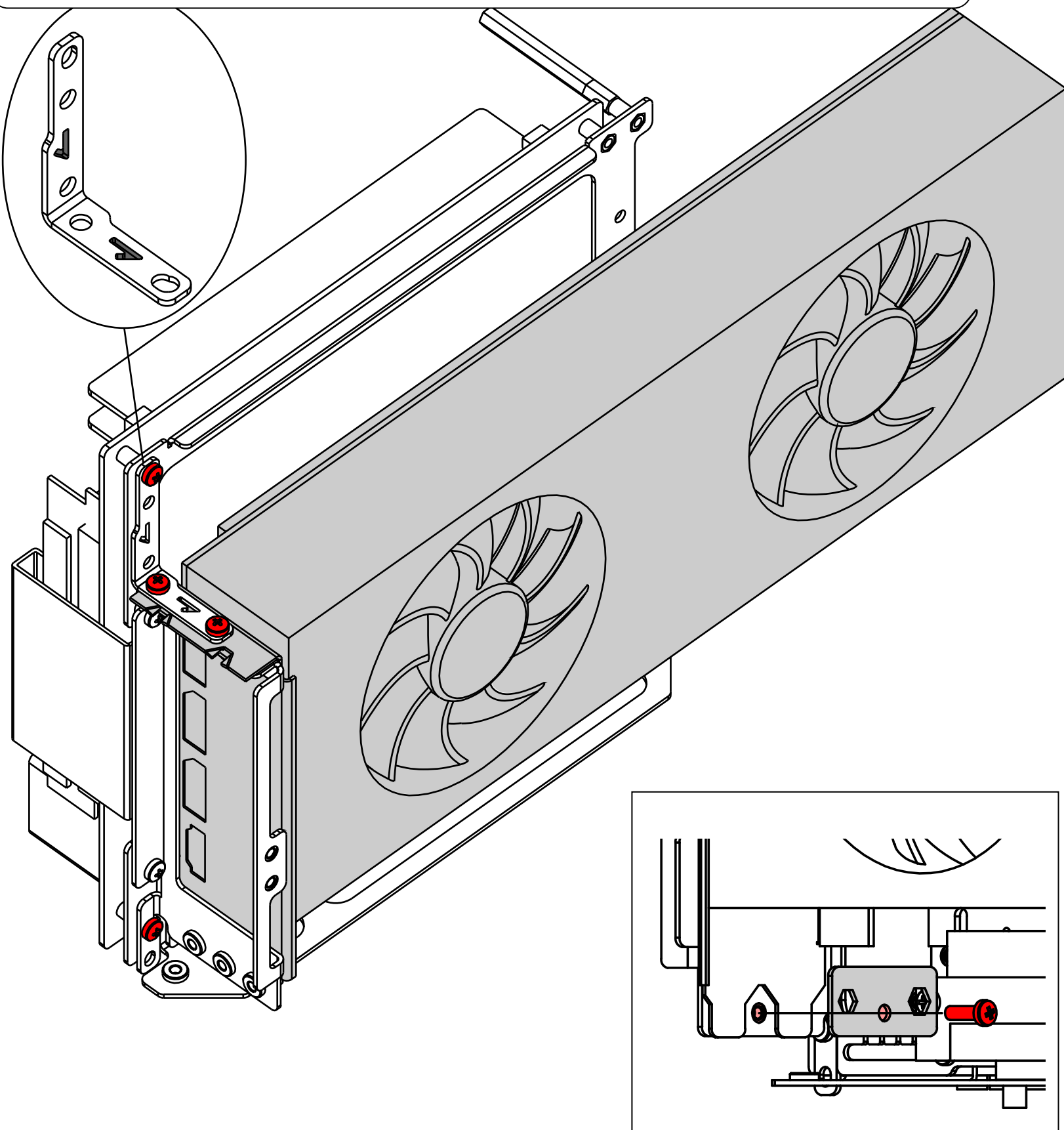

- The graphics card may be offset horizontally and vertically to:
  - Enable compatibility with larger internal display extensions
  - Improve airflow with “pass-through” graphics card coolers
  - Vertical and horizontal shifting requires a VC-S290G4 PCIe riser cable or other 35 cm long PCIe cable

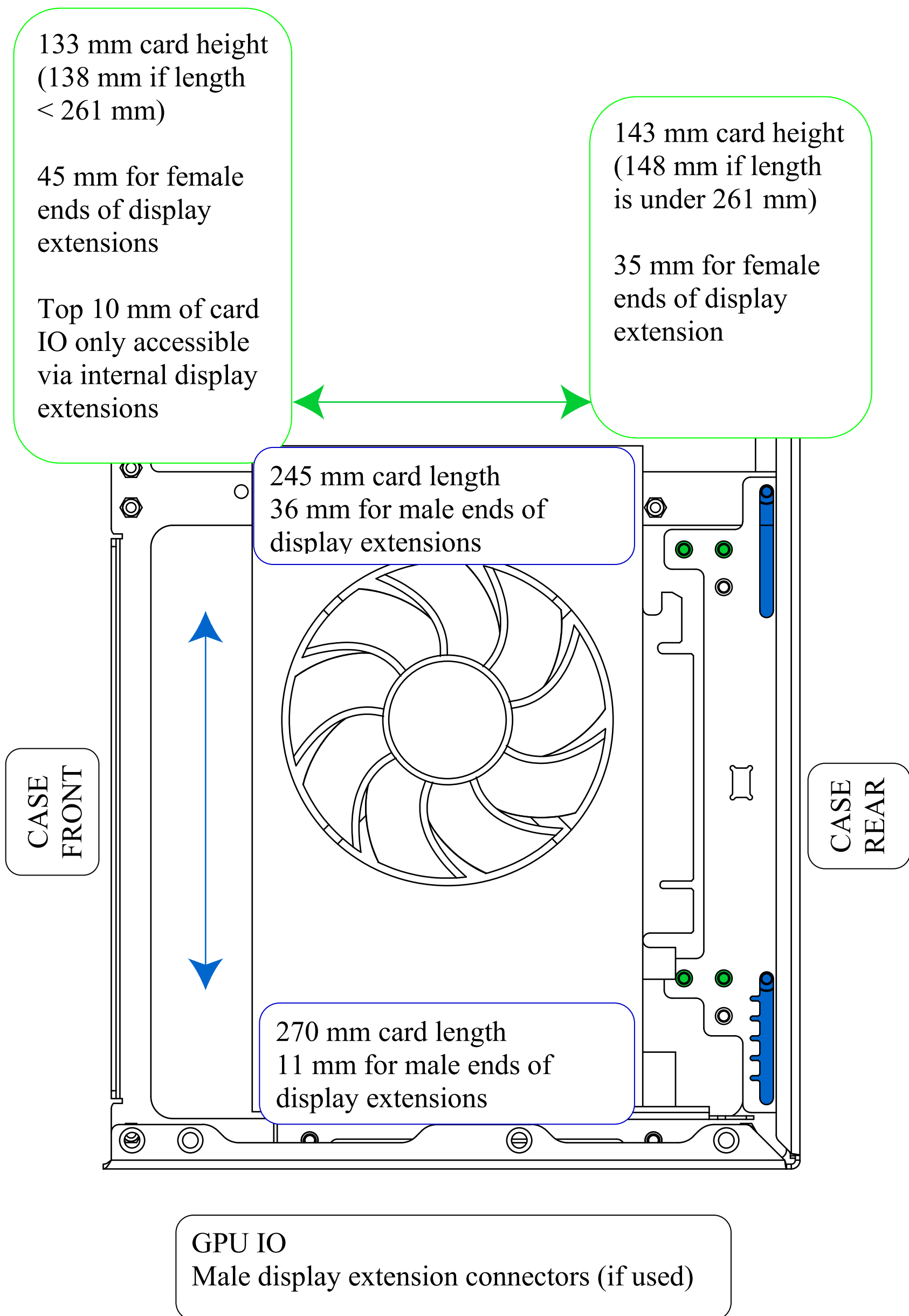

- Maximal 25 mm vertical offset shown below

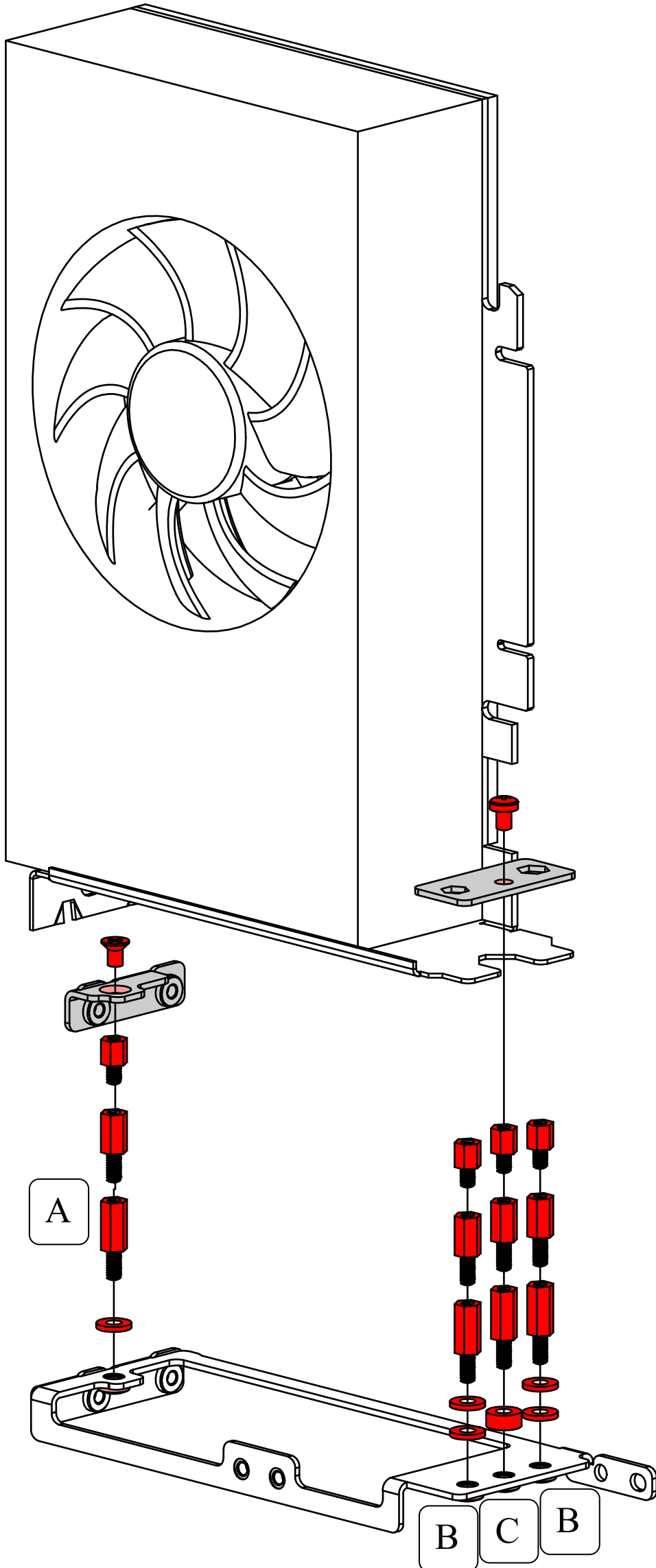

- Vertical graphics card offset

1 = 1 mm spacer

3 = 3 mm spacer

5 = 5 mm standoff

8 = 8 mm standoff

10 = 10 mm standoff

Internal extension male connector clearance (mm)	Stack A composition
11	N/A
22	10
23	10 + 1
24	10 + 1 + 1
25	8 + 5
26	8 + 5 + 1
27	10 + 5
28	10 + 5 + 1
29	10 + 5 + 1 + 1
30	10 + 8
31	10 + 8 + 1
32	10 + 8 + 1 + 1
33	10 + 8 + 3
34	10 + 8 + 3 + 1
35	10 + 8 + 5
36	10 + 8 + 5 + 1

Stack B= Stack A + 1 mm

Stack C= Stack A + 2 mm

Use 1x 3 mm spacer whenever 3x 1 mm spacers are required

## MOTHERBOARD TRAY INSERTION

- Install the motherboard IO shield in the appropriate orientation
- Pay attention to the PCIe cable to prevent it from being caught on any edges

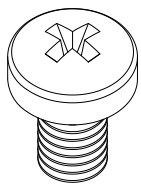

x2

M3x0.5 4 mm round head screw

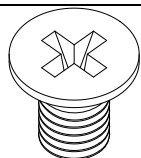

x1

M3x0.5 5 mm countersunk screw

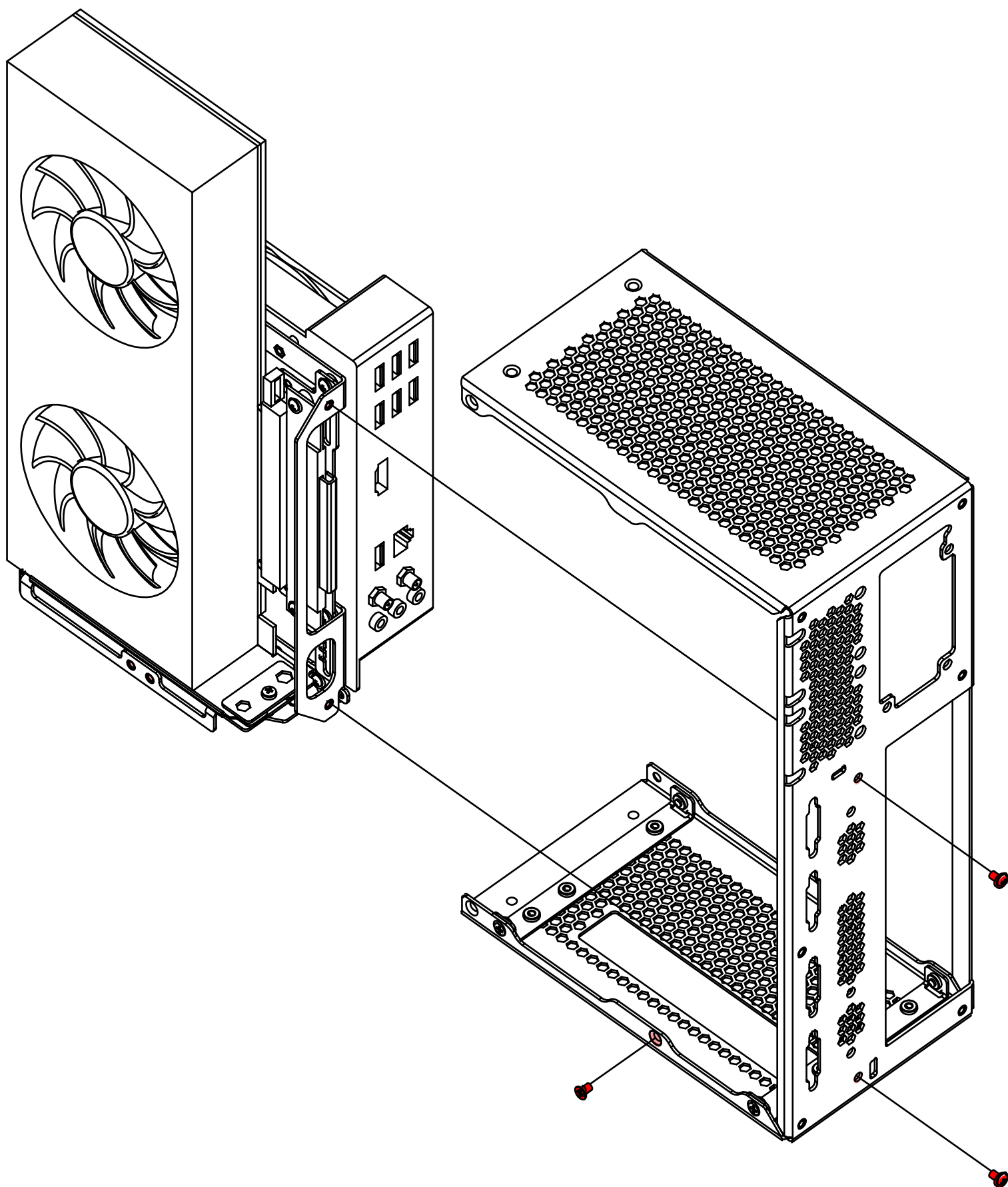

## PSU

- Connect all power cables after mounting the power supply

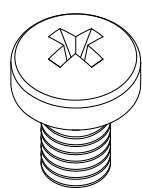

x4

6-32 6 mm round head screw

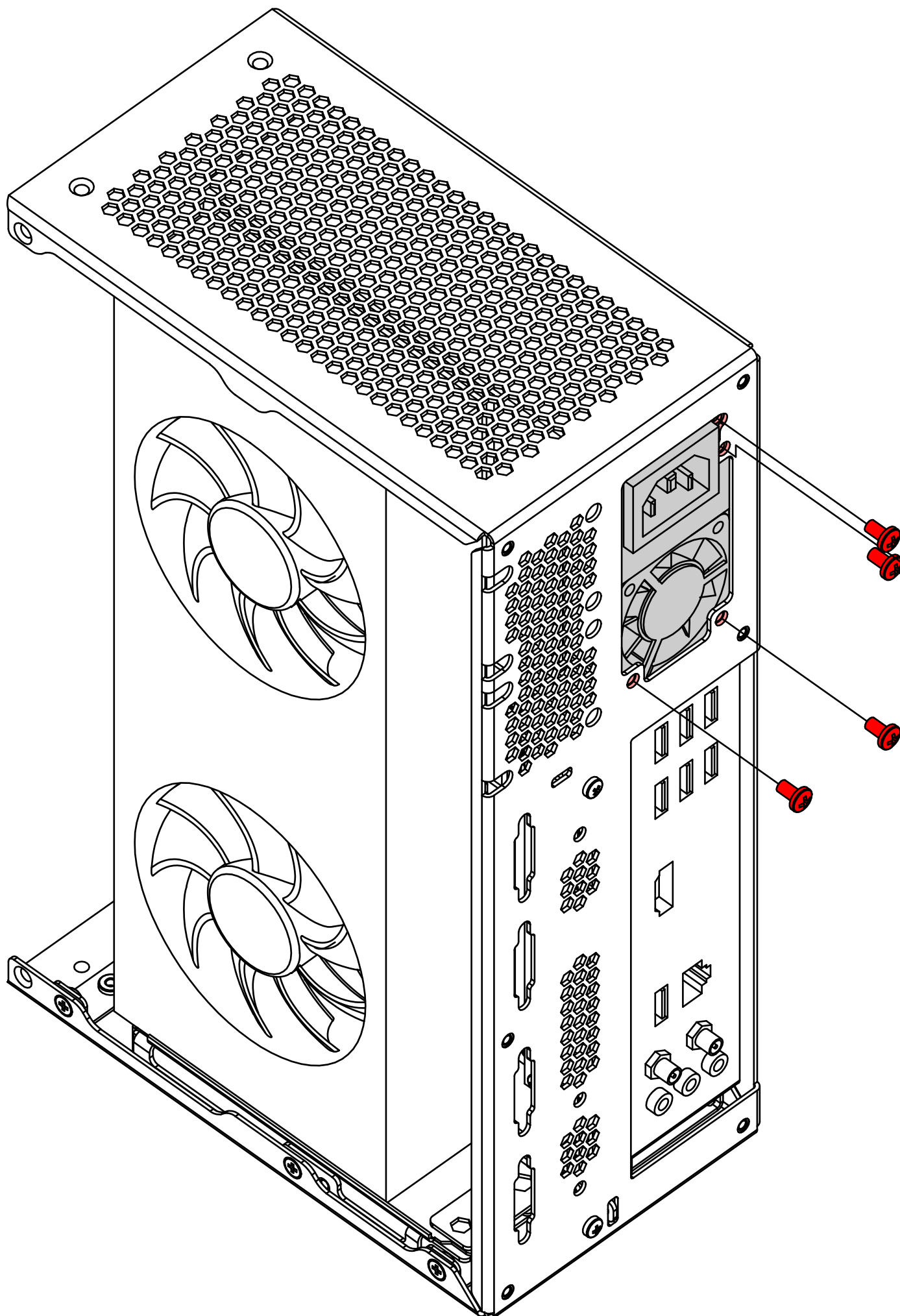

## CASE FANS

- Attach up to 2x 40 mm fans with fan screws (not included)
- Plug in fan headers

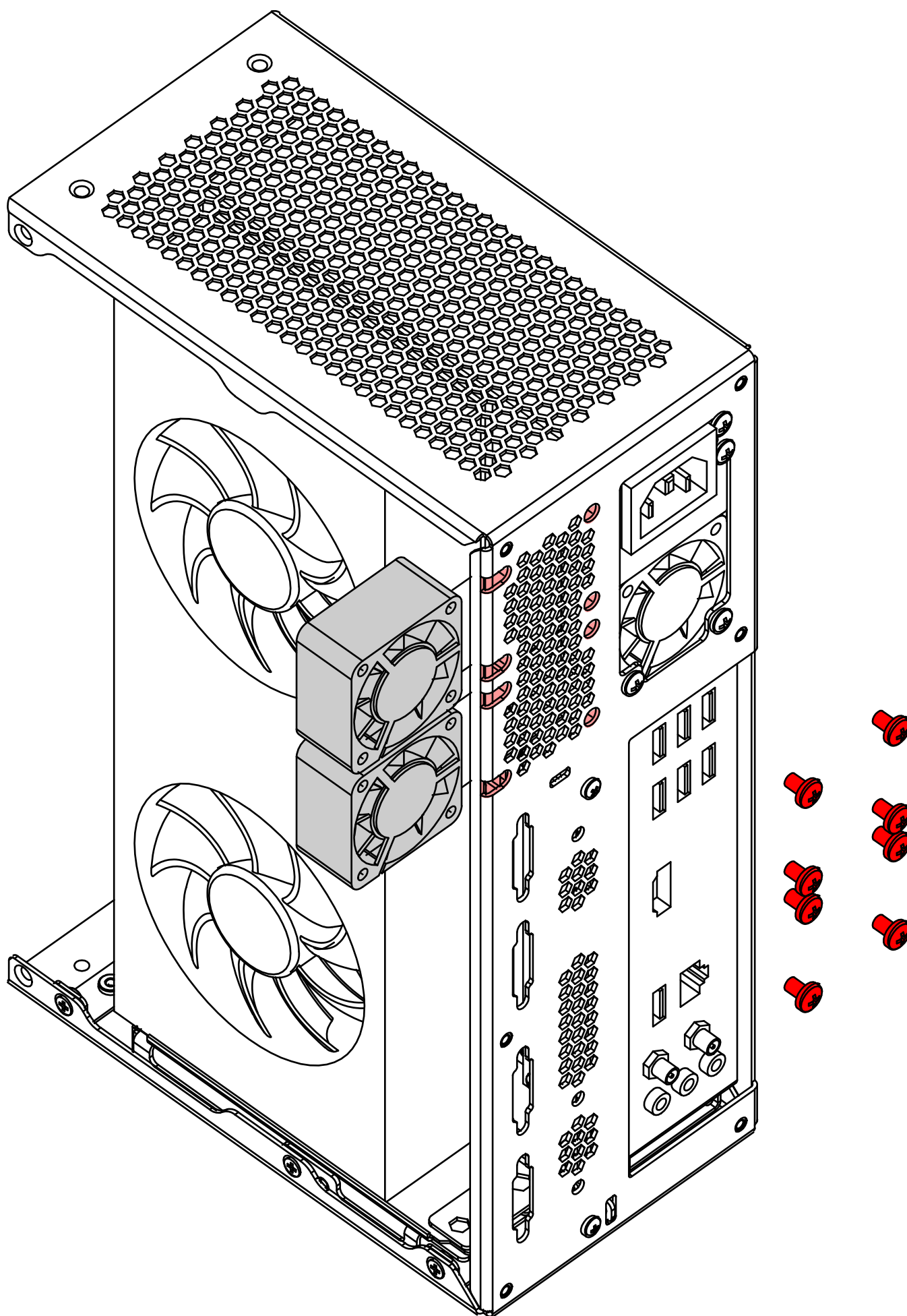

## DEDICATED SATA DRIVE

- Connect the SATA data and power cables to the storage drive and motherboard at this step

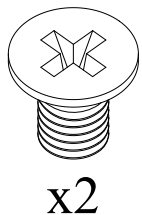

M3x0.5 5 mm countersunk screw

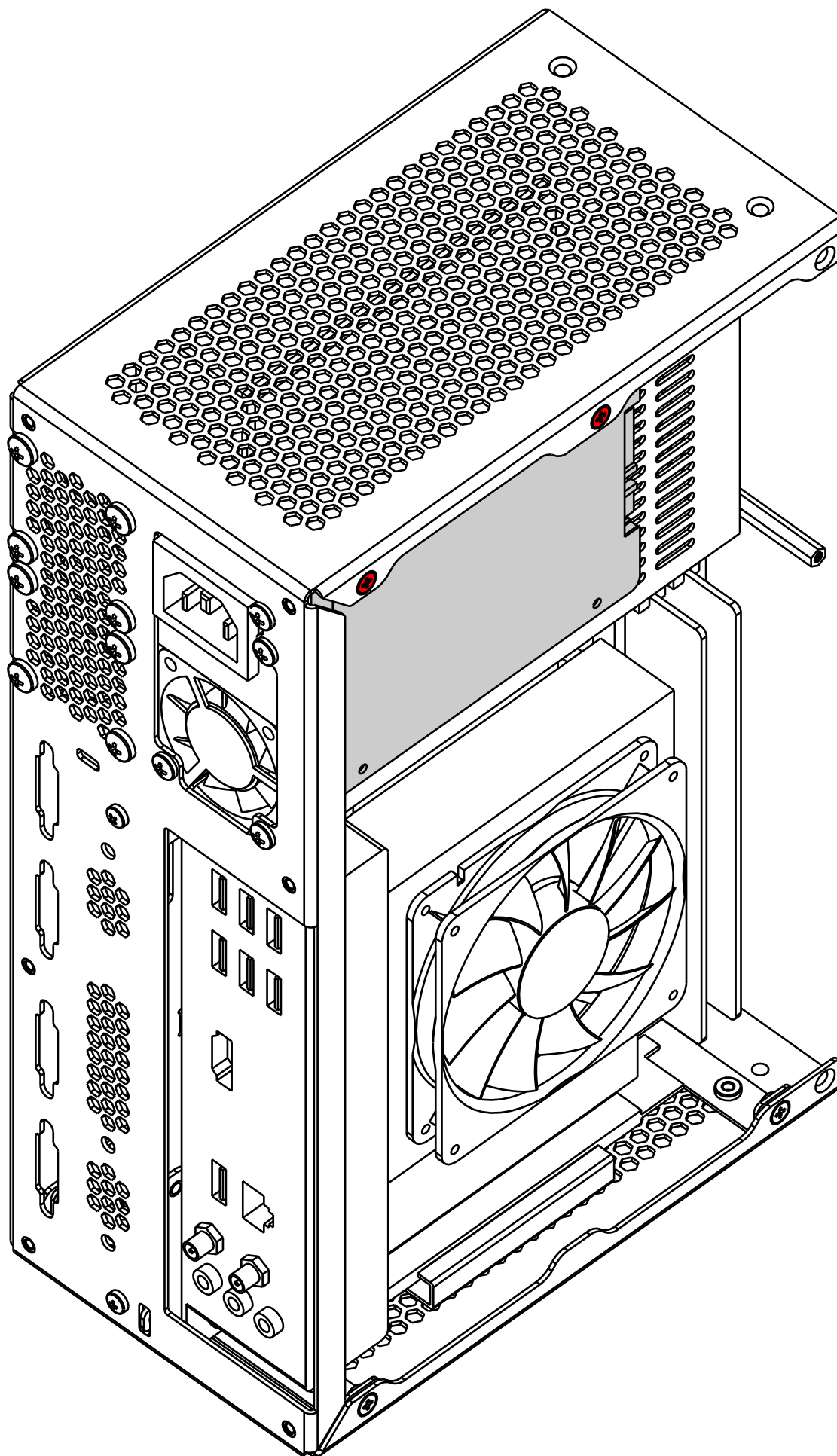



## ADDITIONAL SATA DRIVES

- Graphics card must be  $< 200$  mm in length
- Screws can be hidden by flipping the case and using internal display cable extensions for the graphics card (if applicable)

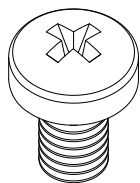

M3x0.5 4 mm round head screw

x2 per drive

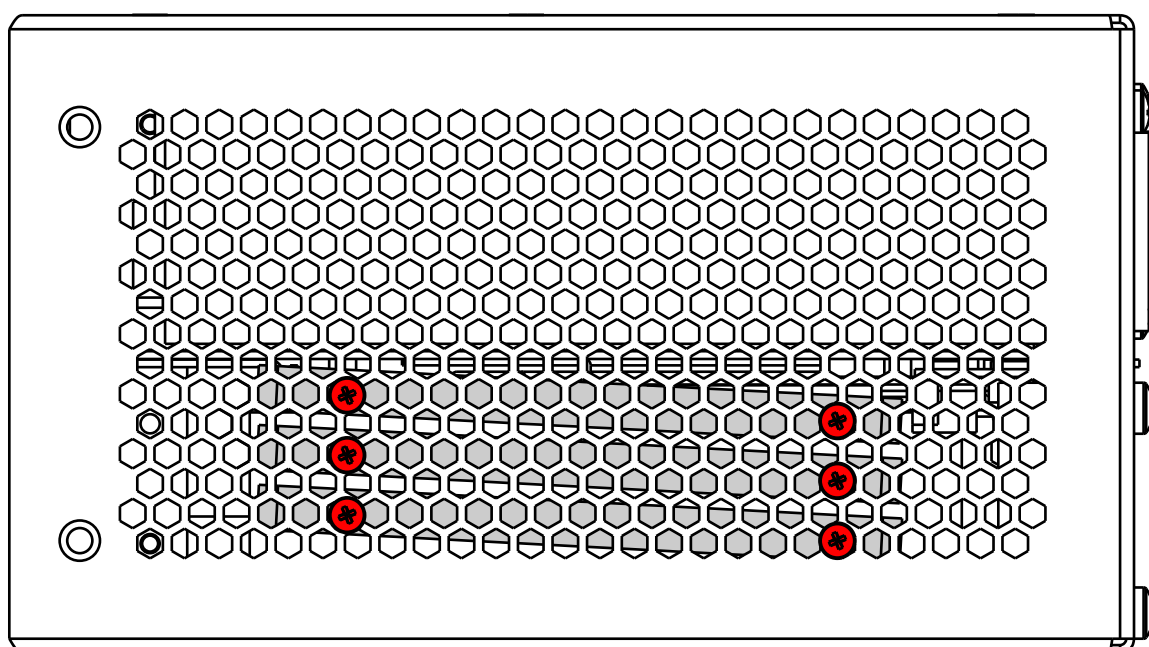

## CLOSING THE CASE, STAND, RUBBER FOOT INSTALLATION

- Install port covers at the case rear if not using display extensions
- Wipe the case surface to improve rubber foot adhesion
- Stick 4 adhesive rubber bumpers onto the bottom of the stand/case of the chosen orientation
- For quieter operation and increased internal clearances, mount the side panels using the adjacent mounting holes. The side panels will bend inwards at the center due to their concave shape, which can be partially mitigated by inserting rubber bumpers between the case body and side panels

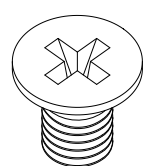

x13

(A)  
M3x0.5 5 mm countersunk screw

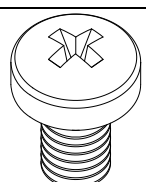

x6

(B)  
M3x0.5 4 mm round head screw

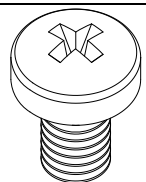

x4

(C)  
M3x0.5 10 mm round head screw

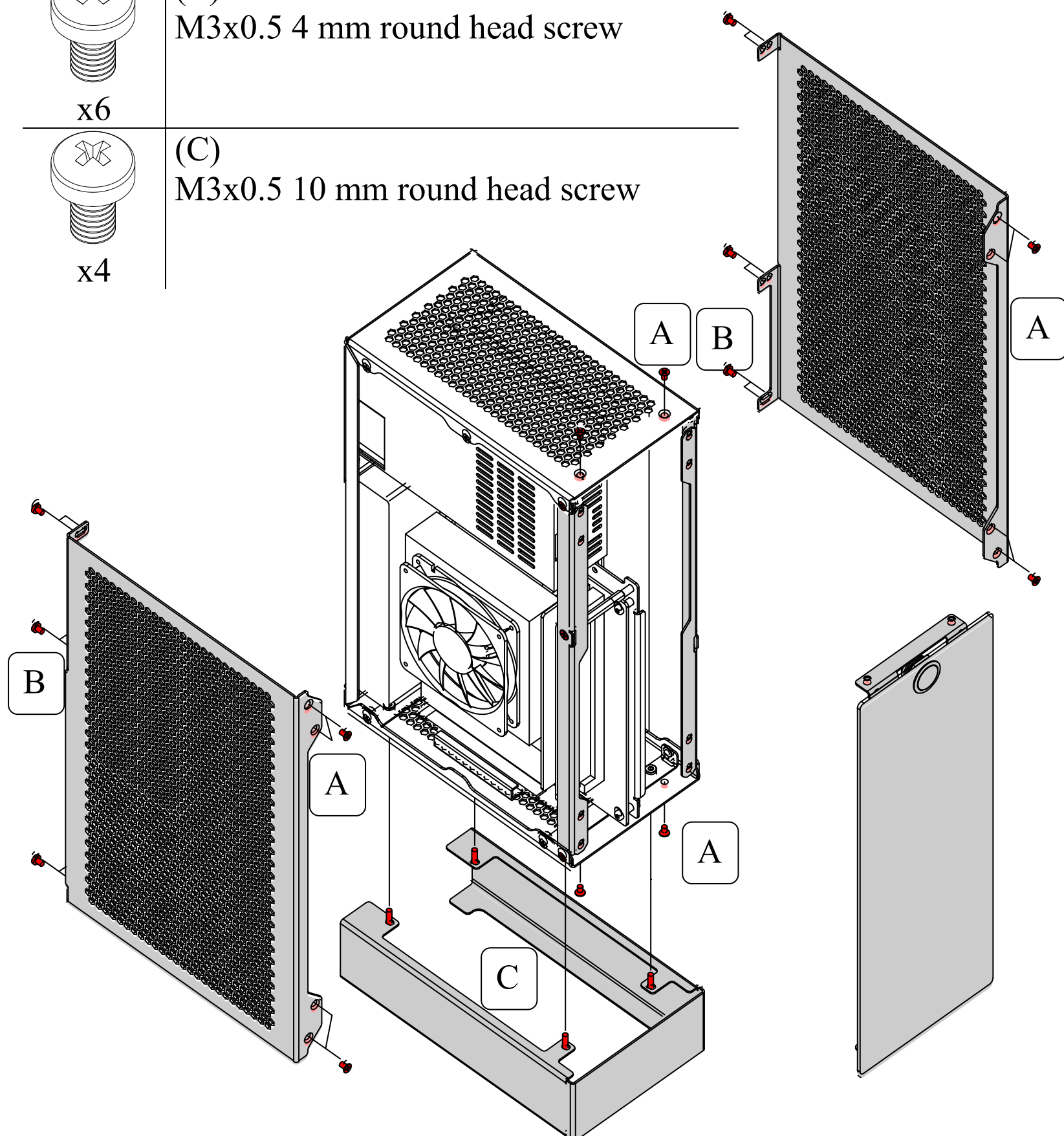

## TROUBLESHOOTING

- Screw heads stripping
  - Ensure that you are using the appropriate #2 Phillips driver for the included screws. Using any other type of driver for the included screws risks damaging the screw heads and eventually making them difficult or impossible to remove. Replace damaged screws.
- System instability or no display output from the graphics card while using PCIe gen 4+ motherboard and graphics card with an older gen PCIe riser cable
  - Manually set PCI link speed in UEFI BIOS to match that of the PCIe riser cable (ex: gen 3). If there is no display output in UEFI BIOS, use onboard graphics (if available) or plug the graphics card directly into the PCIe slot without the cable to change this setting.
- Unstable display output or no display output while using internal video output extension cables
  - Use an internal extension cable that matches the display's requirements or reduce the display's settings to match the bandwidth that the cable supports (ex: DP 1.4 cable for a DP 1.4 display, HDMI 2.1 cable for an HDMI 2.1 display).
  - Avoid converting the signal between different video standards such as DP to/from HDMI. If conversion is absolutely required, use an active adapter cable as opposed to a passive adapter cable or active discrete adapter.
  - Connect to a different graphics card port
  - Use no more than one cable externally to carry the signal to the display. Use the highest quality and shortest cable available.
  - Replace the internal extension cable
  - Connect the external cable directly to the graphics card with or without the use of the case stand

## SUPPORT AND SERVICE

For all inquiries, please email [contact@velkase.com](mailto:contact@velkase.com)

All user manuals: [www.velkase.com/downloads](http://www.velkase.com/downloads)