

# VELKA 3

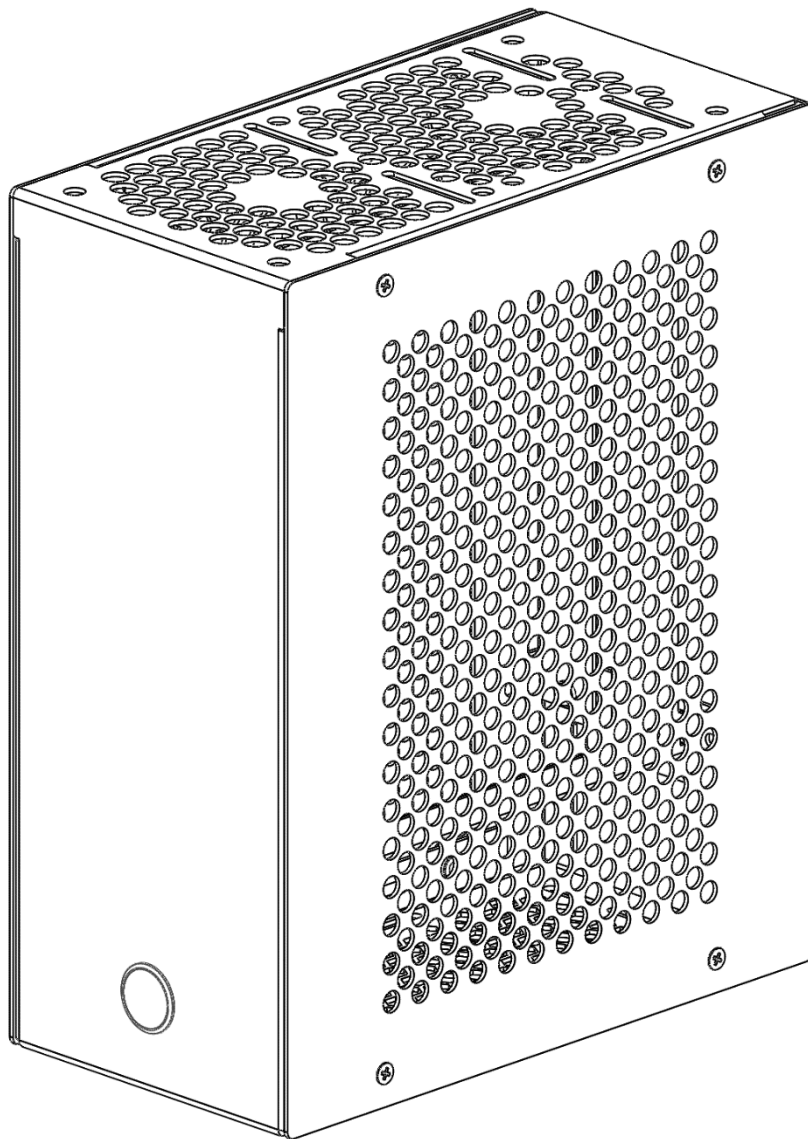

# TABLE OF CONTENTS

- Specifications..... 3
- Included Mounting Hardware..... 5
- System Assembly..... 6**
  - Overview..... 6
  - Required Tools..... 7
  - Component Test Outside of Case ..... 8
  - Motherboard Tray Subassembly (Dual Slot)..... 9
  - Motherboard Tray Subassembly (Single Slot)..... 10
  - PCIe Riser Installation ..... 11
  - Rear PSU Plate Installation (Non-FLEX ATX PSUs only)..... 12
  - Rear Cover Installation ..... 13
  - IO Shield Installation..... 14
  - Connecting Motherboard Tray to Back Panel ..... 15
  - Graphics Card and Storage Installation ..... 16
  - Flex ATX Power Supply Installation and Cable Management..... 18
  - HDPLEX Power Supply Installation ..... 20
  - Front Shell Storage Installation ..... 21
  - Front Shell Fan Installation ..... 23
  - Connecting Front Shell..... 24
  - Side Panel Installation ..... 26

## Specifications

### Case Specifications

Minimum Dimensions (L x W x H)	172 x 97 x 225 mm excluding protrusions 184 x 97 x 228 mm including protrusions	
Maximum Dimensions (L x W x H)	187 x 97 x 225 mm excluding protrusions 187 x 97 x 228 mm including protrusions	
Volume (liters)	At minimum length: 3.7 L external, 3.6 L internal At maximum length: 4.1 L external, 3.9 L internal	
Desk footprint (excluding protrusions and cables)	At minimum length: 170 cm <sup>2</sup> At maximum length: 180 cm <sup>2</sup>	
Weight	0.55 kg (1.2 lb)	
Form Factor	Small form factor	
Materials	Front shell	1.2 mm anodized brushed aluminum
	Side panels	1.2 mm anodized sandblasted aluminum
	Back panel	1.2 mm powder-coated aluminum
	Rear cover	1.2 mm powder-coated aluminum
	Motherboard tray	1.0 mm powder-coated steel
	Power button	anodized aluminum

## Hardware compatibility

Motherboard	Mini ITX 170 x 170 mm
Power supply	Flex ATX: 150 x 81.5 x 40.5 mm With external AC-DC adapter: <ul style="list-style-type: none"> <li>• HDPLEX 400W HiHi DC-ATX (takes up one CPU side 2.5” drive space)</li> <li>• HDPLEX 200W DC-ATX (single slot mode only)</li> <li>• MiniBox picoPSU-160-XT/150-XT</li> </ul> rev 1.0 and 1.1 are <b>only</b> compatible with Flex ATX power supplies
CPU cooler	Dual slot mode: 37 mm Single slot mode: 52 mm*  *Wraith Stealth and most other coolers have 57 mm clearance
Expansion card (L x W x H)	Dual slot mode at maximum case length: 185* x 43 x 142 mm Single slot mode at maximum case length: 185* x 22 x 142 mm  rev 1.0 and 1.1 limit length to 183 mm
Memory	Dual slot mode: 42 mm Single slot mode: 57 mm
2.5” drives	1 - 5. See “Hardware configurations” below.
Case fans	80 x 80 x 10 mm Quantity: 2
PCIe riser	LiHeat 300 mm D type
Power Button	16 mm panel cutout diameter. 18 x 18 x 20 mm

## Hardware configurations

Expansion slots available	CPU cooler clearance	Expansion slots used	Top fan(s)	2.5" mounts
2	37	2	Yes	1
1	52	1	Yes	1
2	37	2	No	2
1	52	1	No	2
1 or 2	37 or 52	0	Yes	3
1	52	0	No	4
2	37	0	No	5

## Included Mounting Hardware

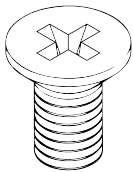

20x screws  
M3x0.5 (#4-40)  
For most parts

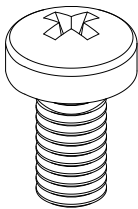

4x 6-32 screw  
M3.5x0.6 (#6-32)  
For power supply

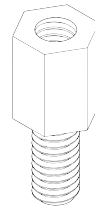

4x 6 mm standoffs

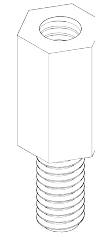

3x 7 mm standoffs



3x 20 mm standoffs

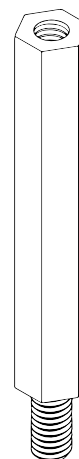

3x 30mm standoffs  
M3x0.5 (#4-40)  
For motherboard

# System Assembly

## Overview

Case must be disassembled prior to installing hardware.

Some users may experience difficulties when building in a Velka case for the first time. To prevent back-tracking during the build process, please briefly review the following build order before following the guide step-by-step.

The following guide includes steps for assembly of the most complicated setup with a 37 mm CPU cooler, dual slot graphics card, and one 2.5” drive, and two case fans. Some sections may be skipped depending on your hardware configuration. For instance, riser installation and expansion card installation sections do not apply to builds without an expansion card.

The following drawings do not show cables.

1. Prepare motherboard, CPU, CPU cooler, M.2 storage. Install direct plug in PSU if applicable (HDPLEX 200W DC-ATX, MiniBox picoPSU, etc)
2. Install motherboard onto tray. Install extra standoffs into tray if the cooler backplate does not fit without them
3. Install PCIE riser
4. Attach rear cover if in single slot mode. Install extra PSU plate if using a non-Flex ATX PSU. Insert IO shield into back panel.
5. Attach motherboard tray to back panel, install expansion card and storage
6. Install power supply, connect main 24 pin, EPS 4+4 pin, PCIE 6+2 pin, SATA connectors
7. Front shell: install cooling fans and storage
8. Connect power button, fans, storage to motherboard and power supply
9. Slide front shell onto components, connect shell to standoffs, install side panels

## Required Tools

- #2 Phillips head screwdriver required (magnetic tip recommended)

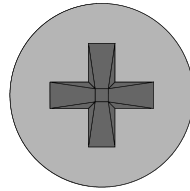

## Component Test Outside of Case

- Please inspect internal components for defects and ensure that all are functional prior to building in the case
- Test PCIE riser



# Motherboard Tray Subassembly (Dual Slot)

37 mm cooler clearance

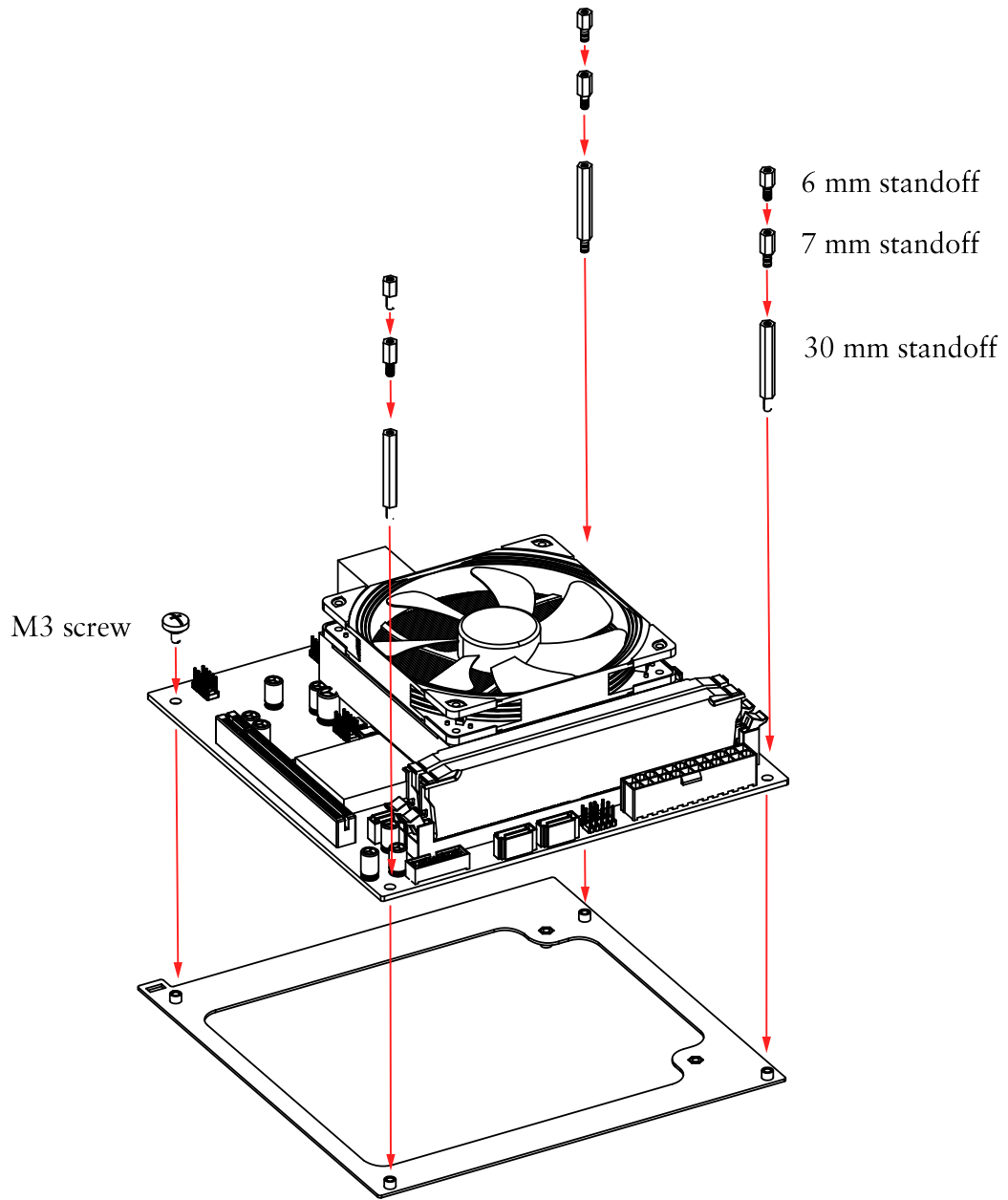

### Motherboard Tray Subassembly (Single Slot)

Most coolers:  
57 mm clearance

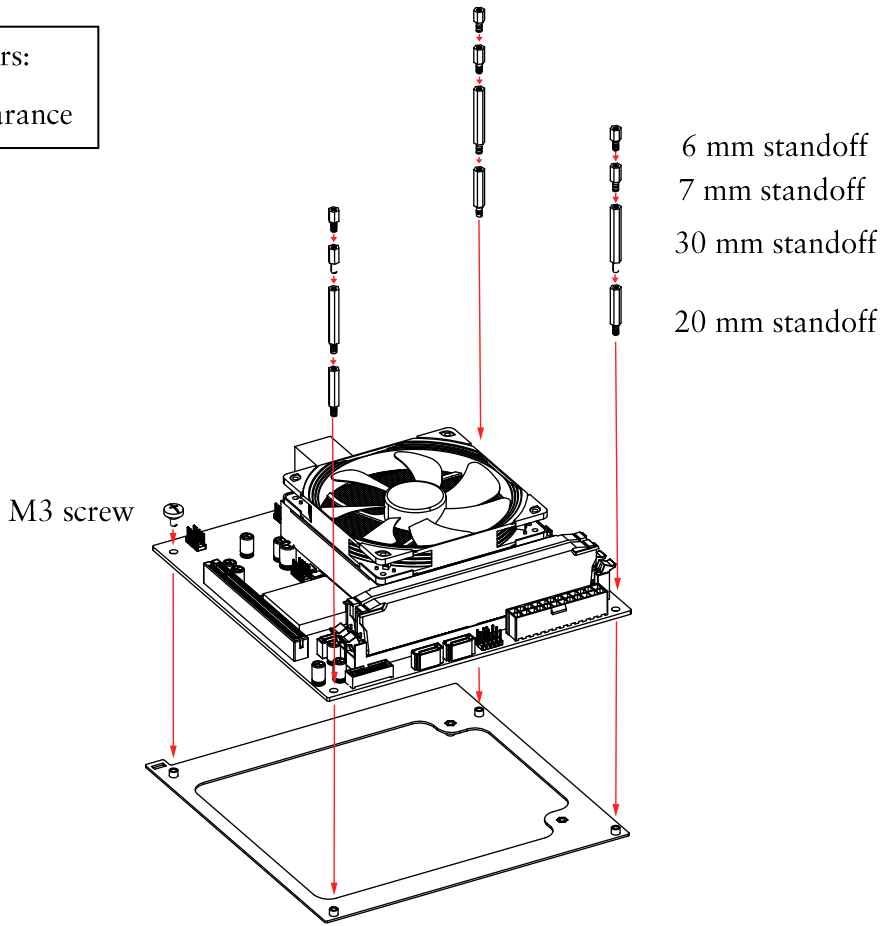

Coolers with oversized backplates:  
52 mm clearance

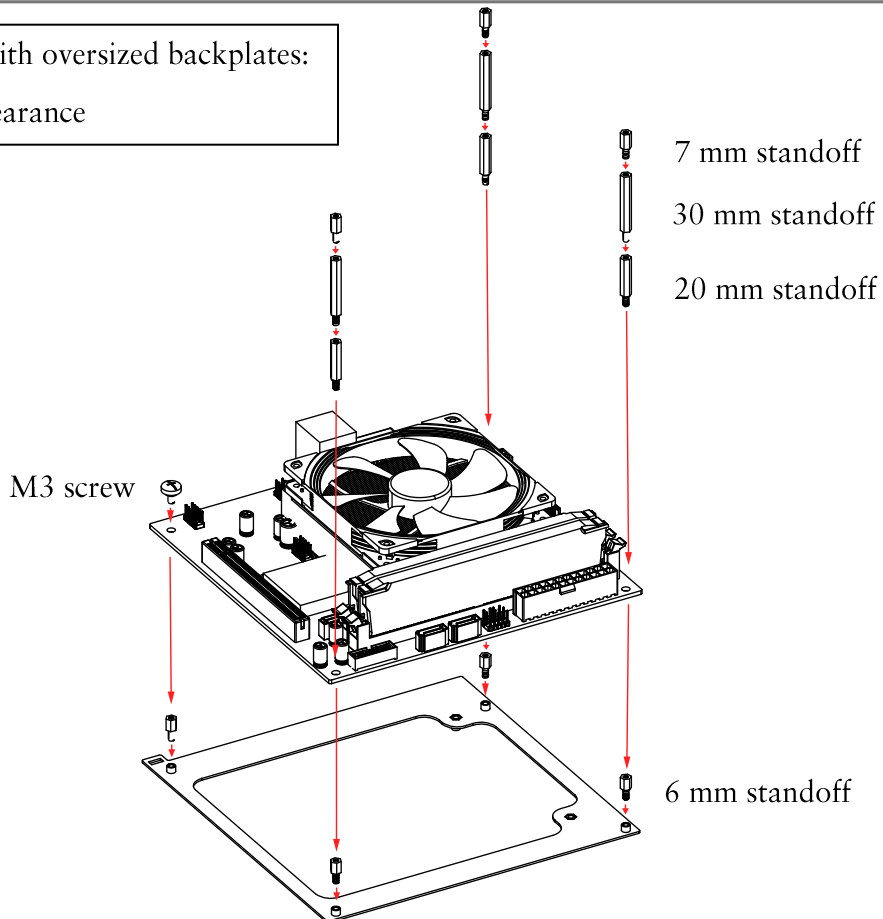

# PCIe Riser Installation

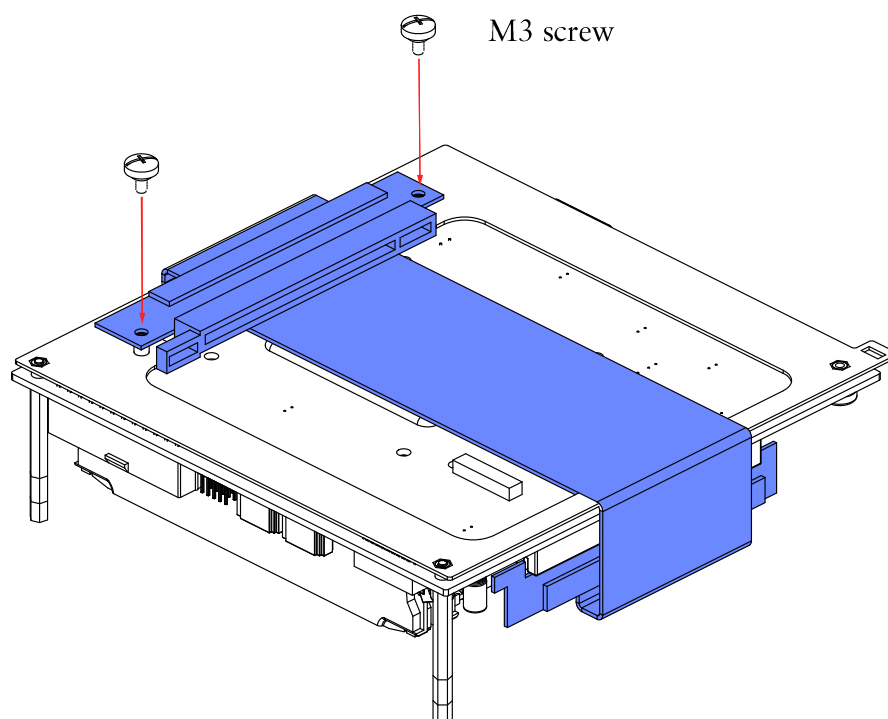
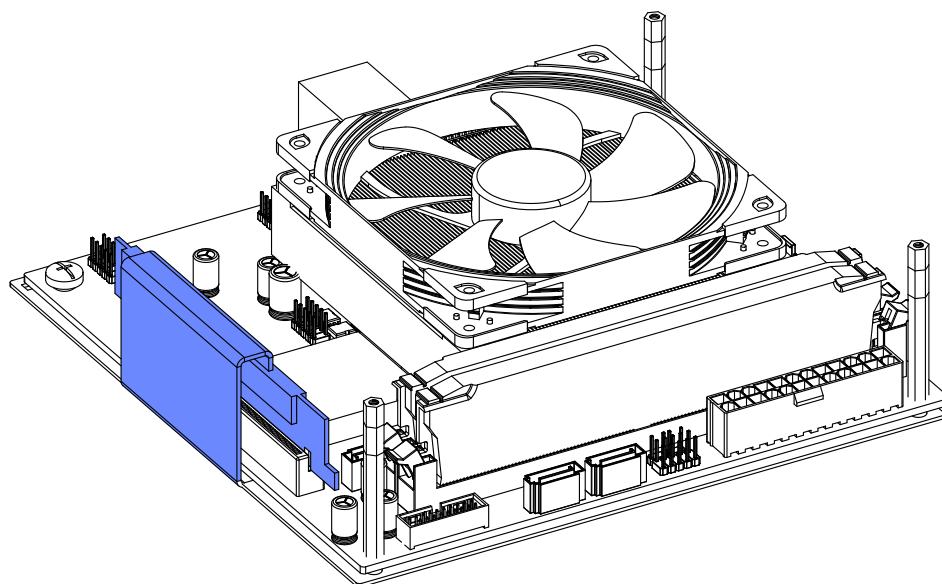

## Rear PSU Plate Installation (Non-FLEX ATX PSUs only)

Openings are highlighted

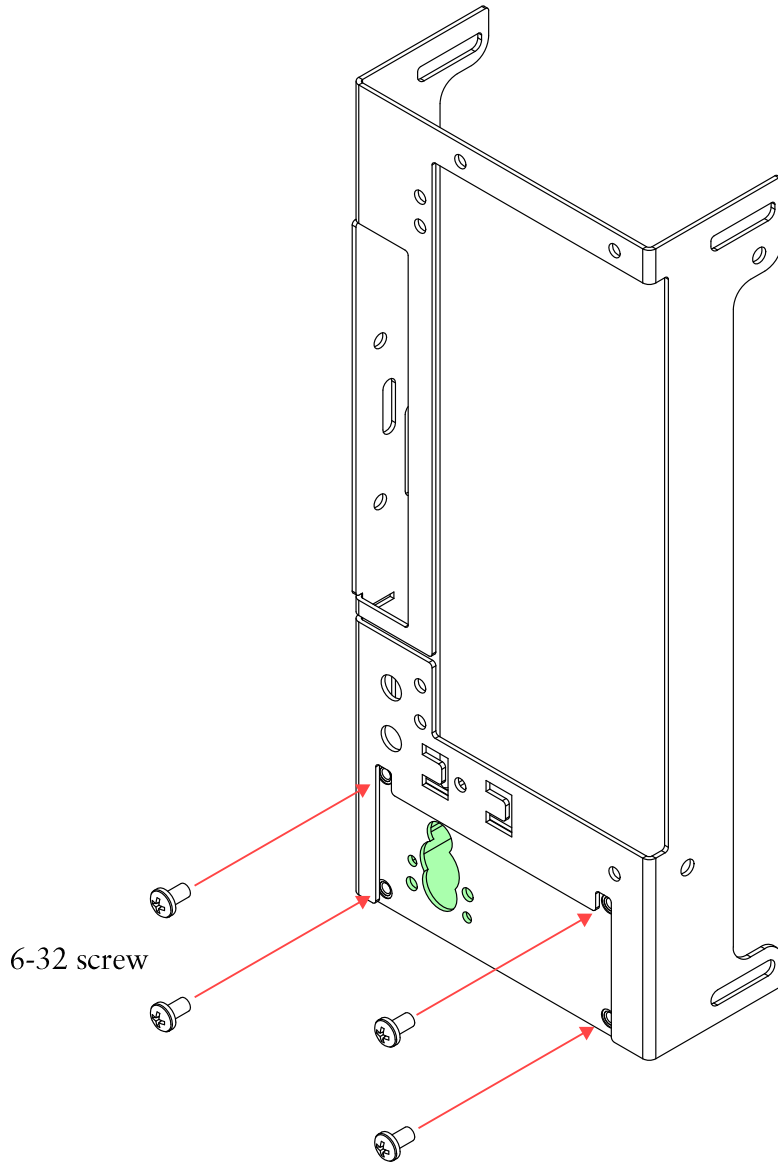

## Rear Cover Installation

Dual slot configuration  
without expansion card

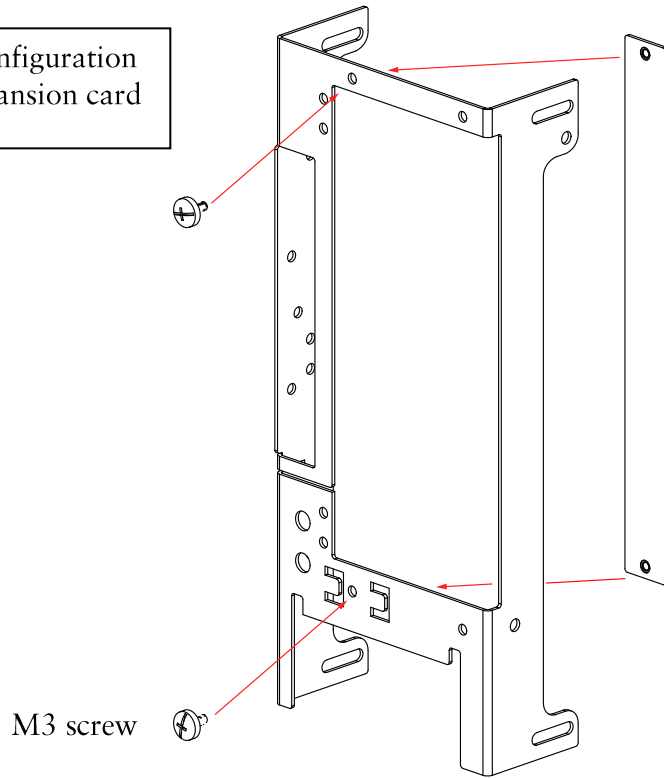

Single slot configuration

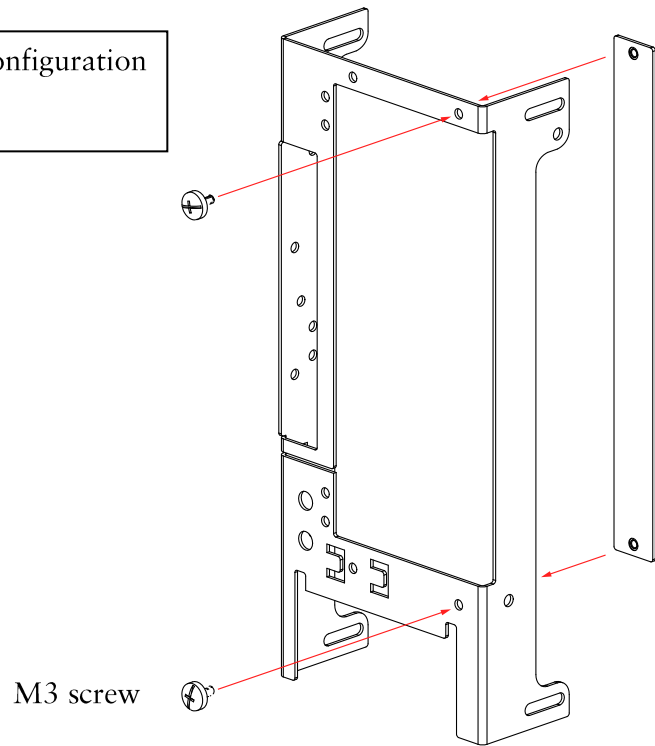

## IO Shield Installation

Openings are highlighted

Dual slot (37 mm)

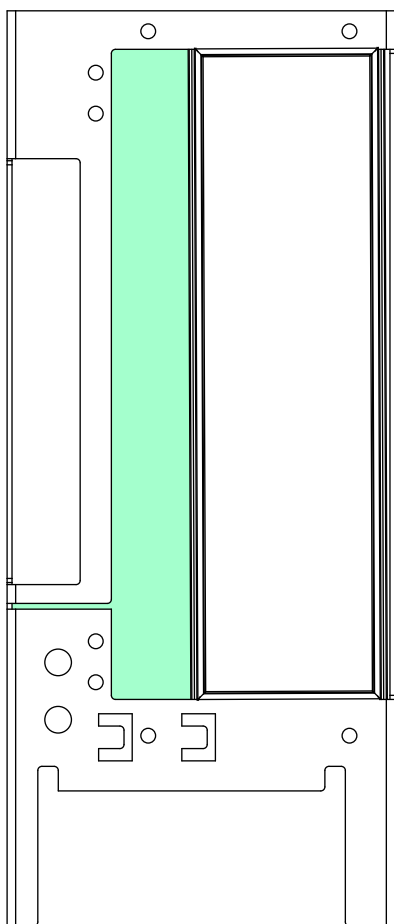

Single slot (57 mm)

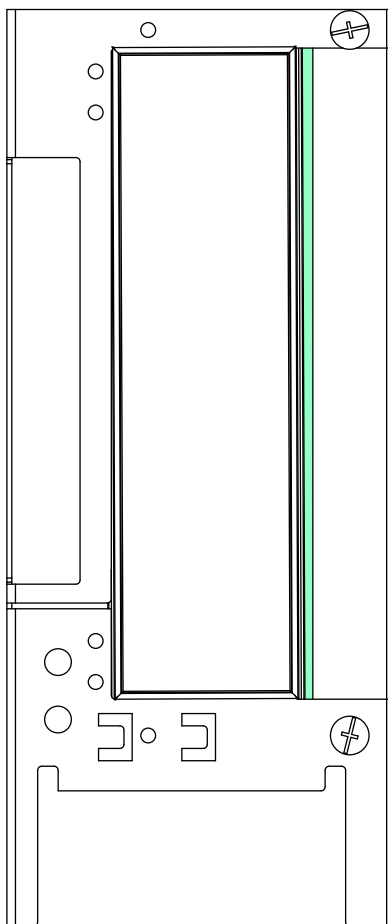

Single slot (52 mm)

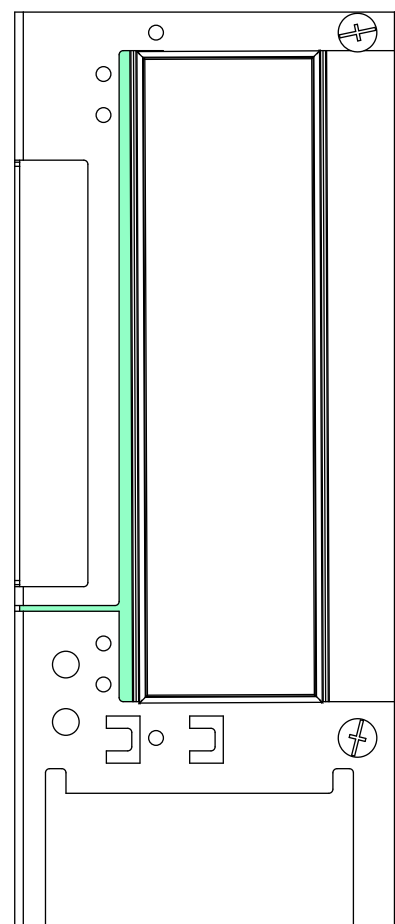

### Connecting Motherboard Tray to Back Panel

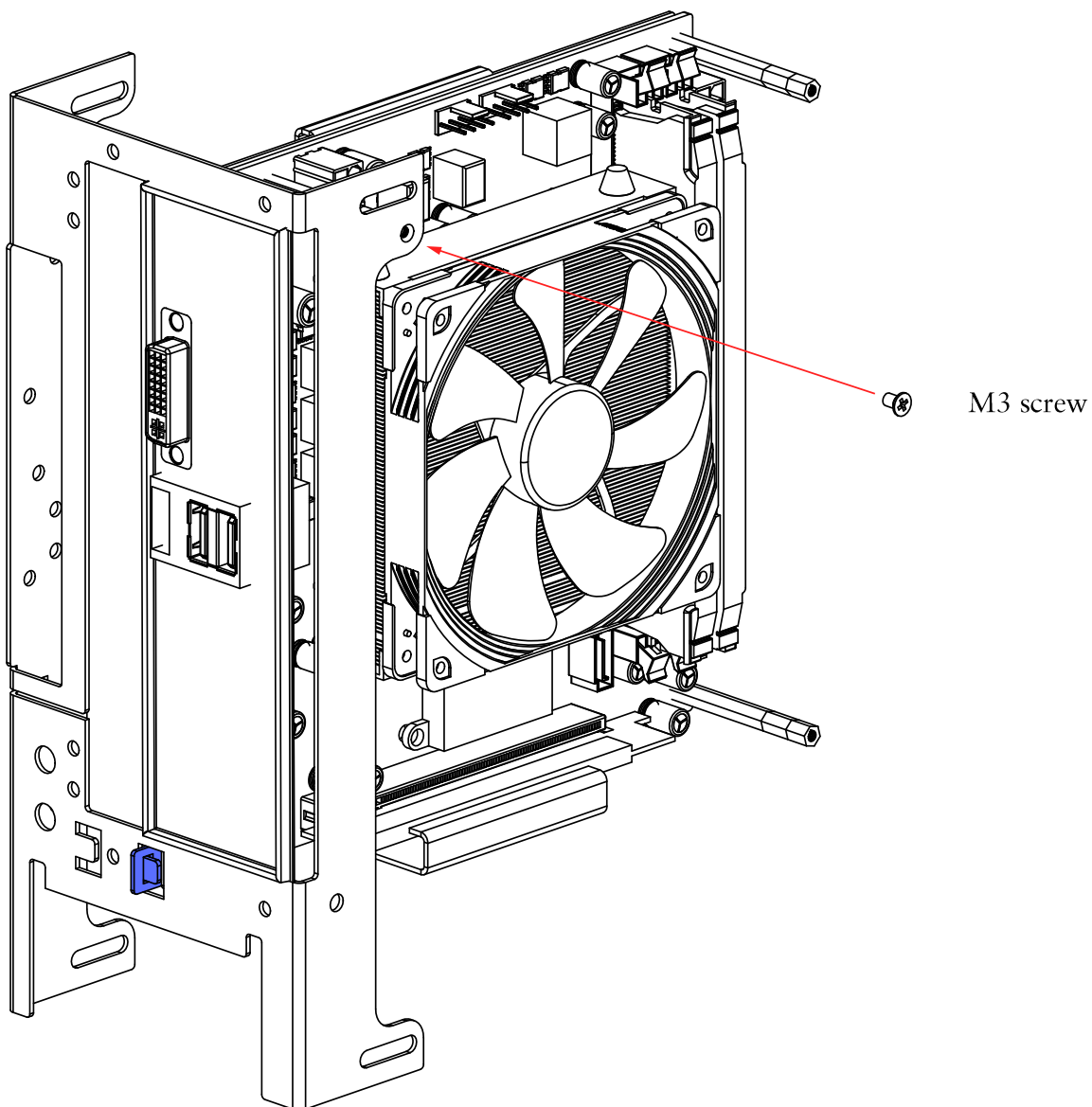
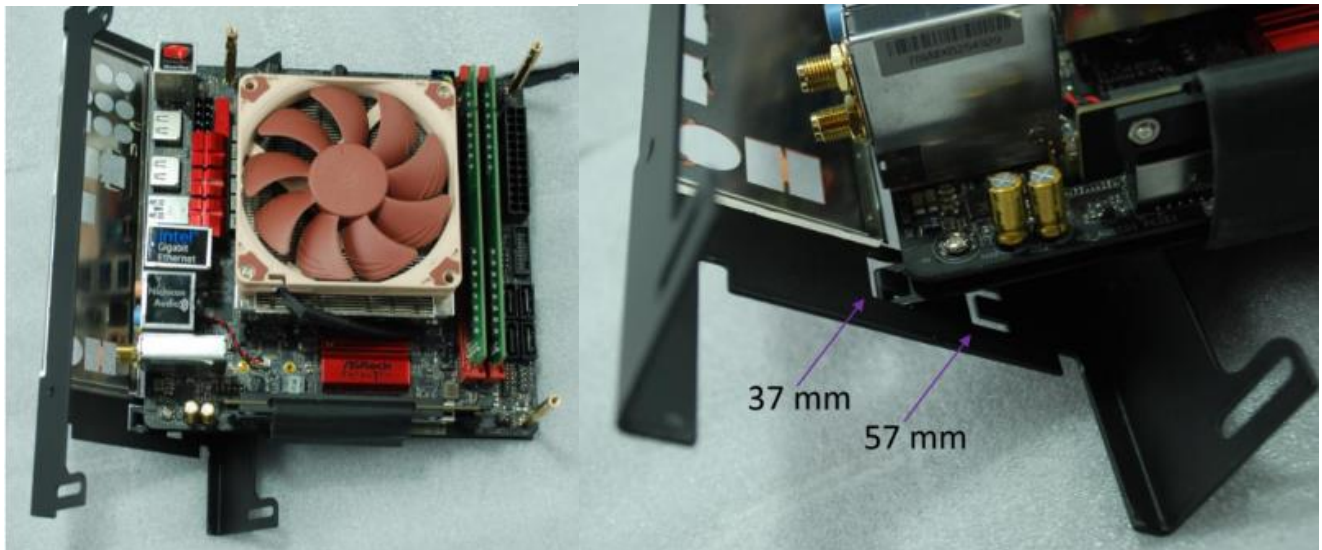

## Graphics Card and Storage Installation

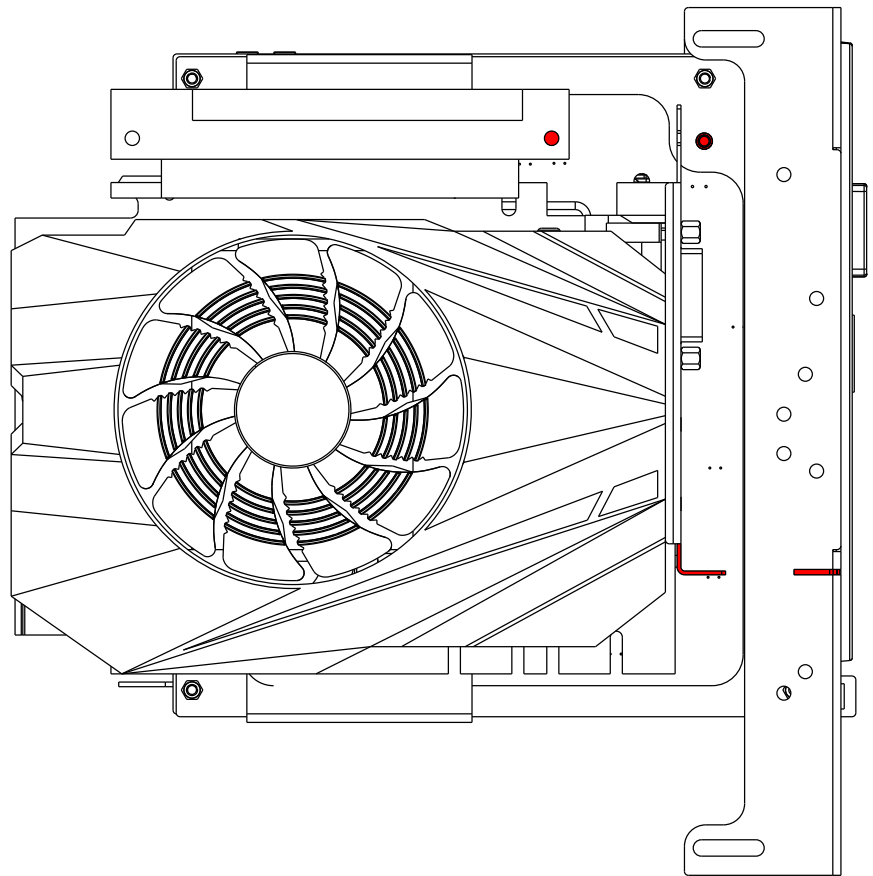

1. Unscrew riser
2. Connect card to riser
3. Line up red features, slide in
4. Screw in riser with M3 screws

M3 screw

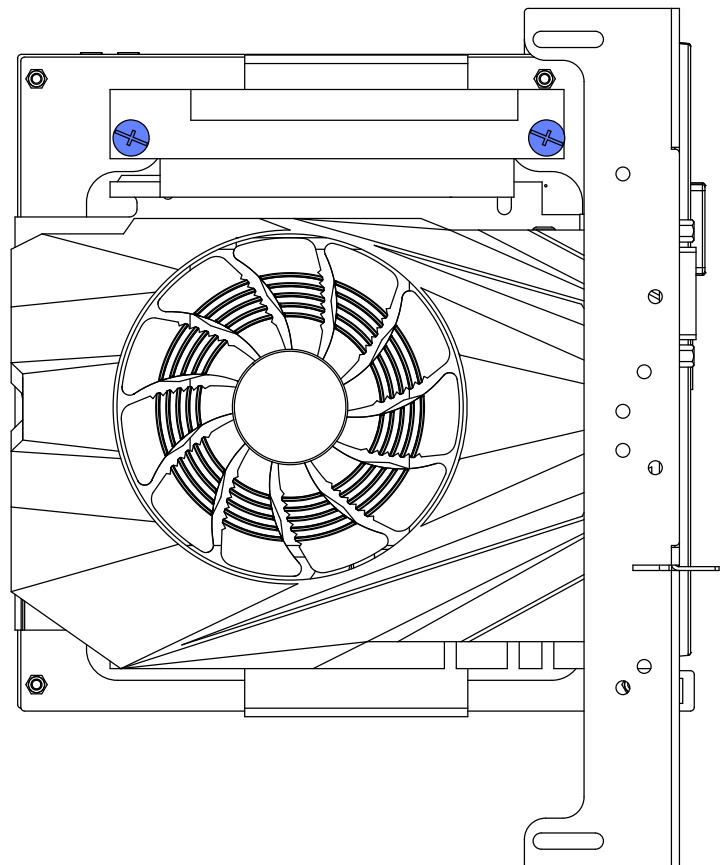



### Storage option 1: two horizontal drives

- Replaces expansion card
- One or two slot mode

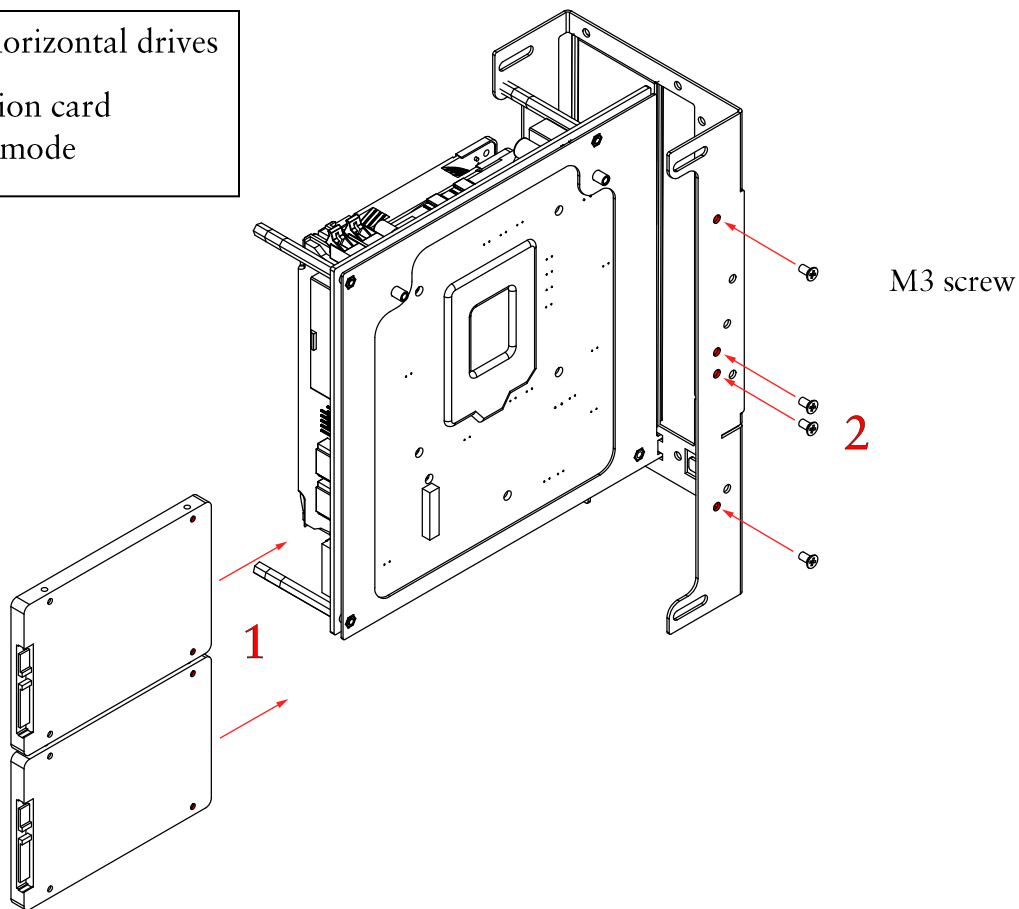

### Storage option 2: one vertical drive

- Replaces expansion card
- One or two slot mode
- One more drive can be installed vertically onto front shell (see “Front Shell Storage Installation”)

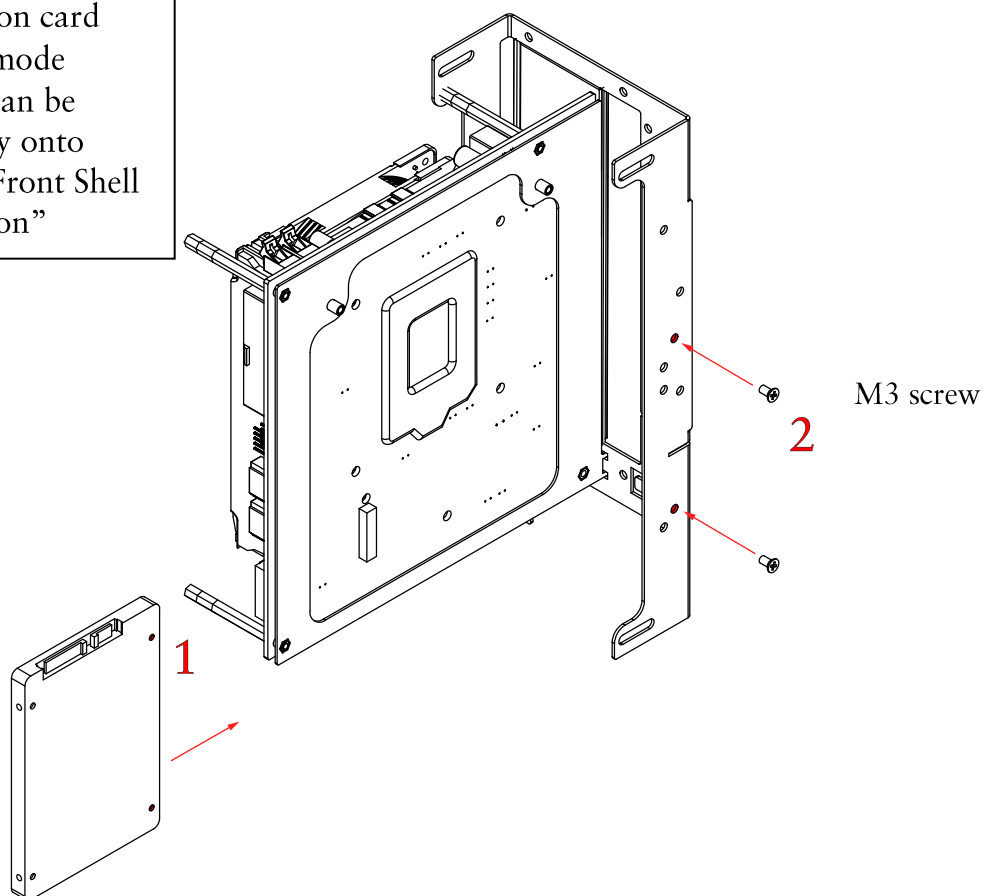

# Flex ATX Power Supply Installation and Cable Management

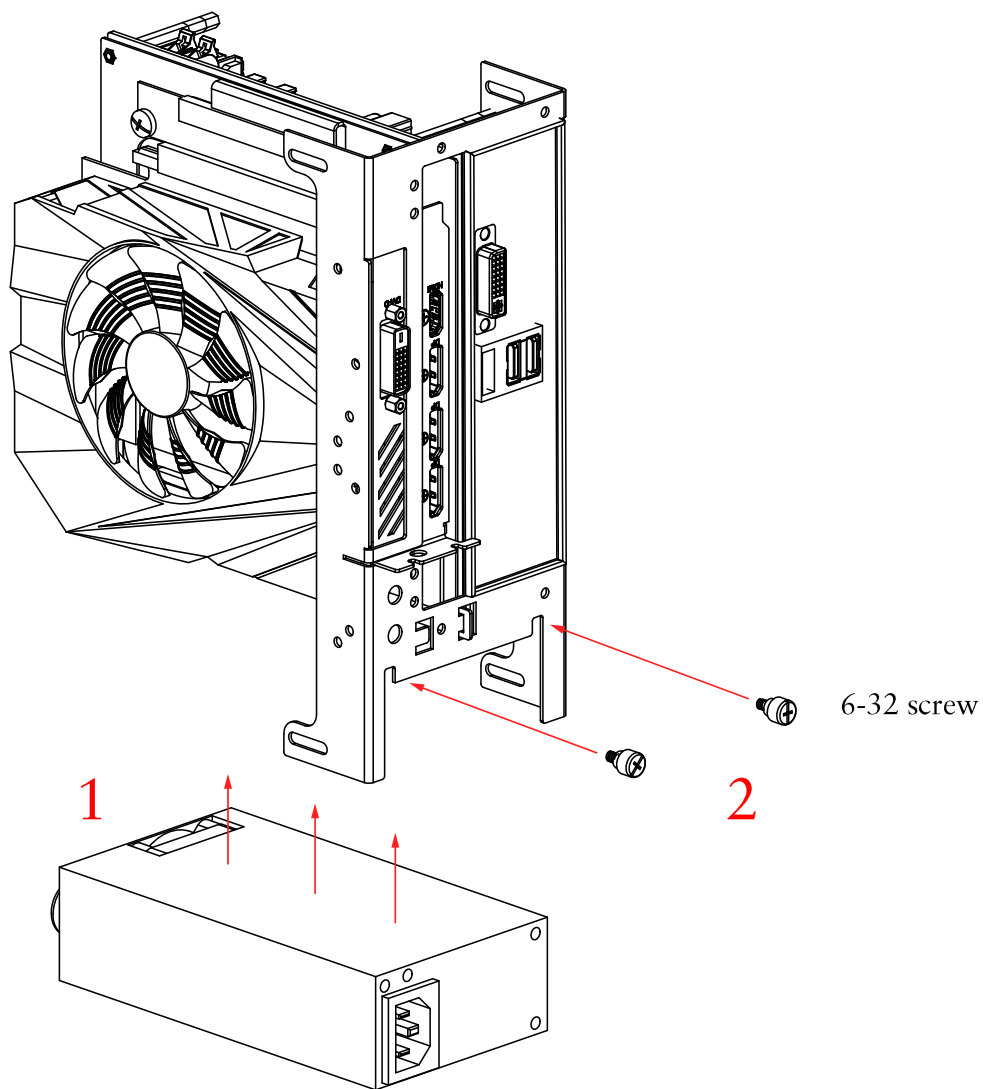

Route main 24 pin and CPU 4 + 4 pin connectors under standoff

Plug in cables: main 24 pin, CPU 4+4 pin, SATA

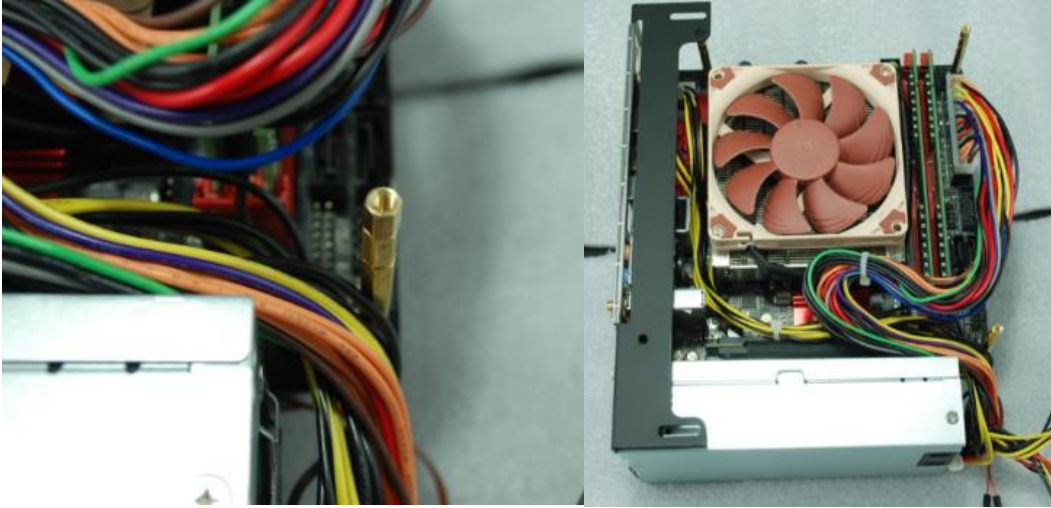

Plug in cables: PCIE 6+2 pin



# HDPLEX Power Supply Installation

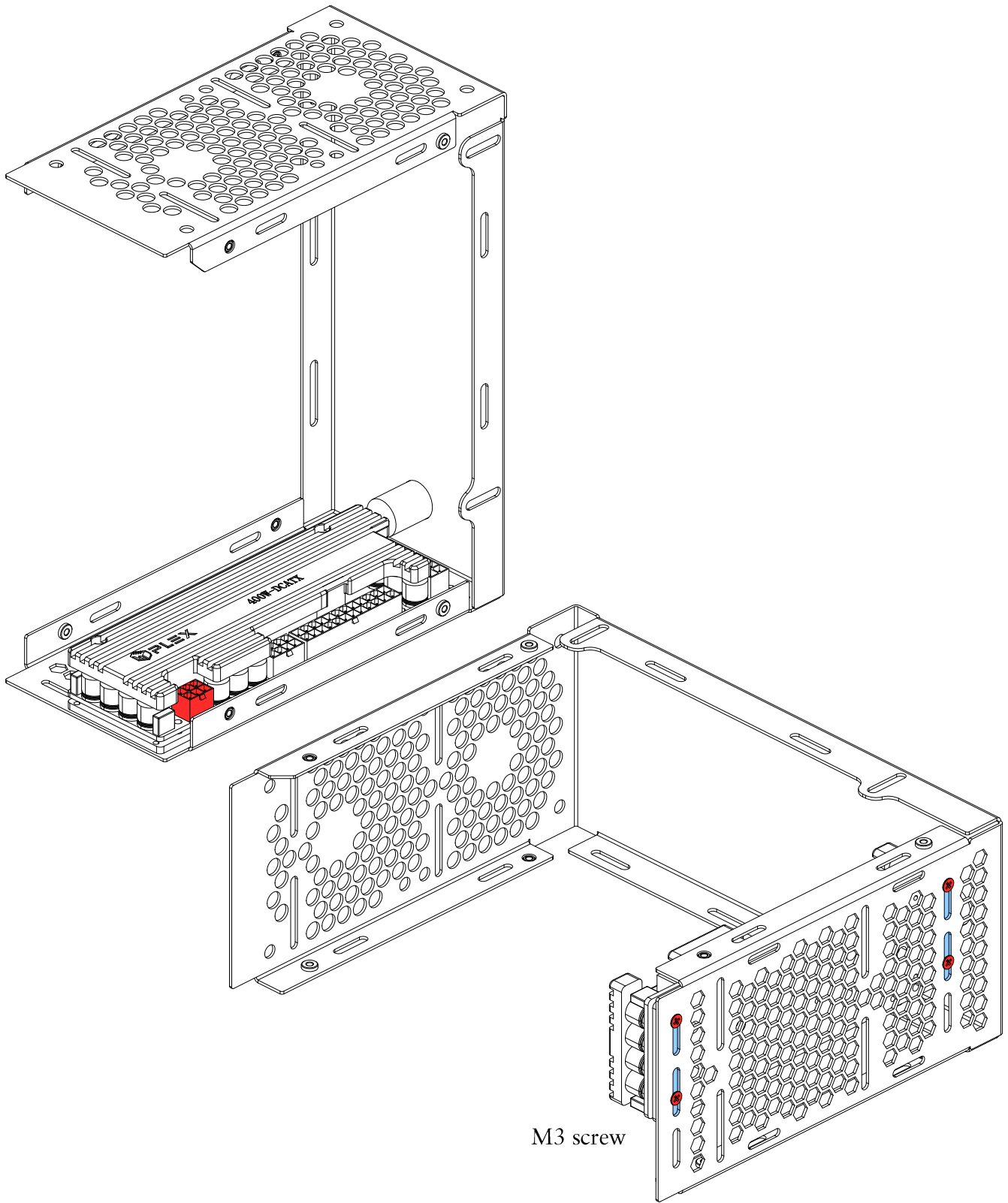

M3 screw

# Front Shell Storage Installation

Storage option 1: top mounted drive

- Replaces two top fans
- One or two slot mode
- Does not interfere with any expansion cards

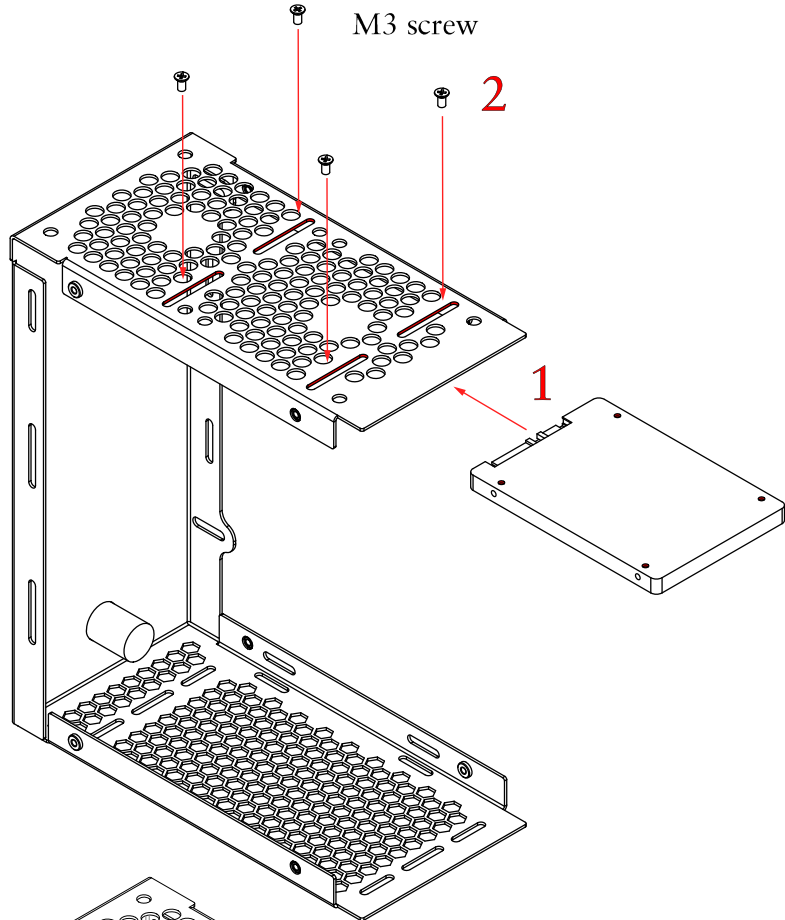

Storage option 2: side mounted drive

- Replaces expansion card
- Can be used with fans
- One or two slot mode
- Works with vertically mounted back panel drive

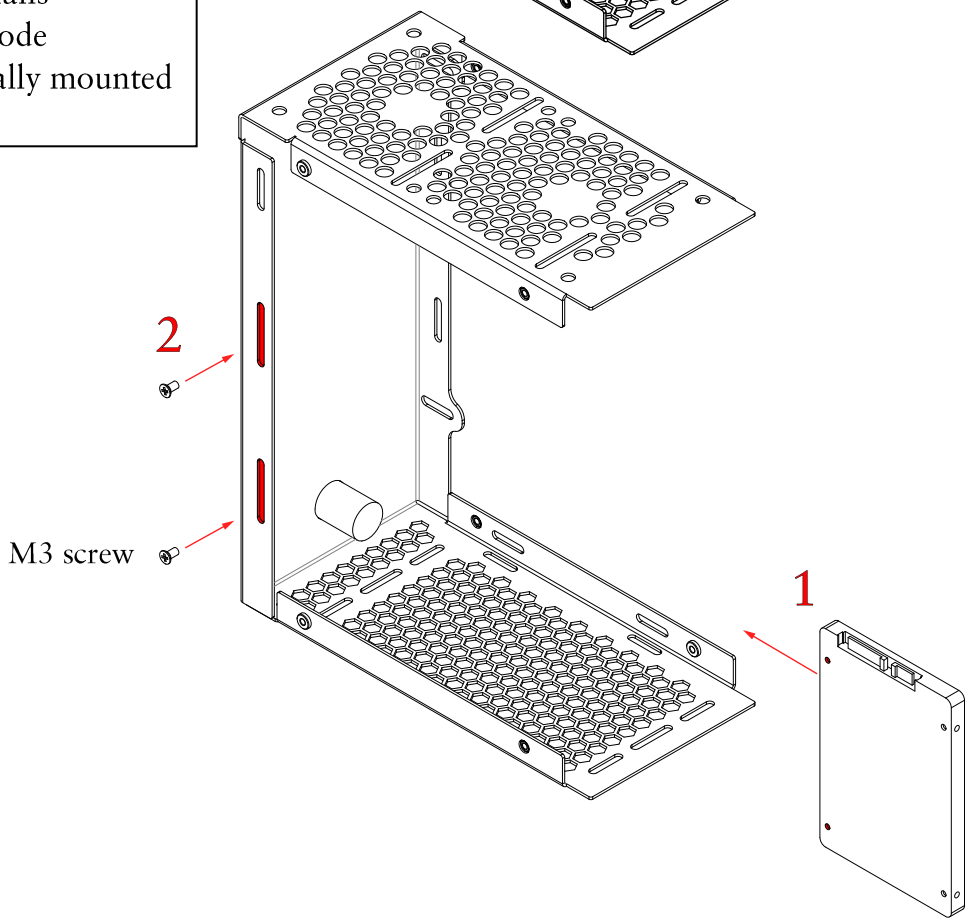

Additional storage option: CPU side mounted drive

- Compatible with all configurations

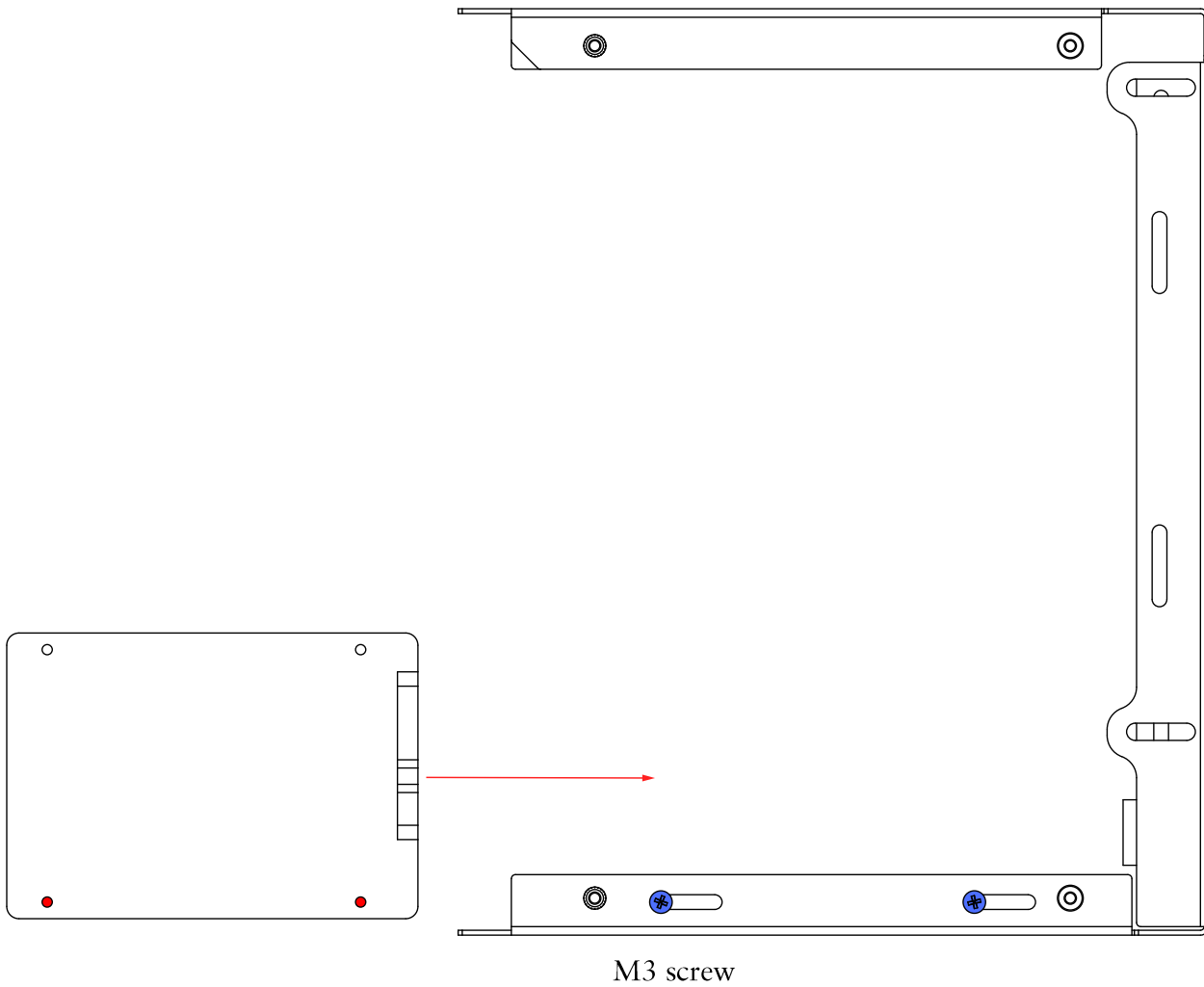

# Front Shell Fan Installation

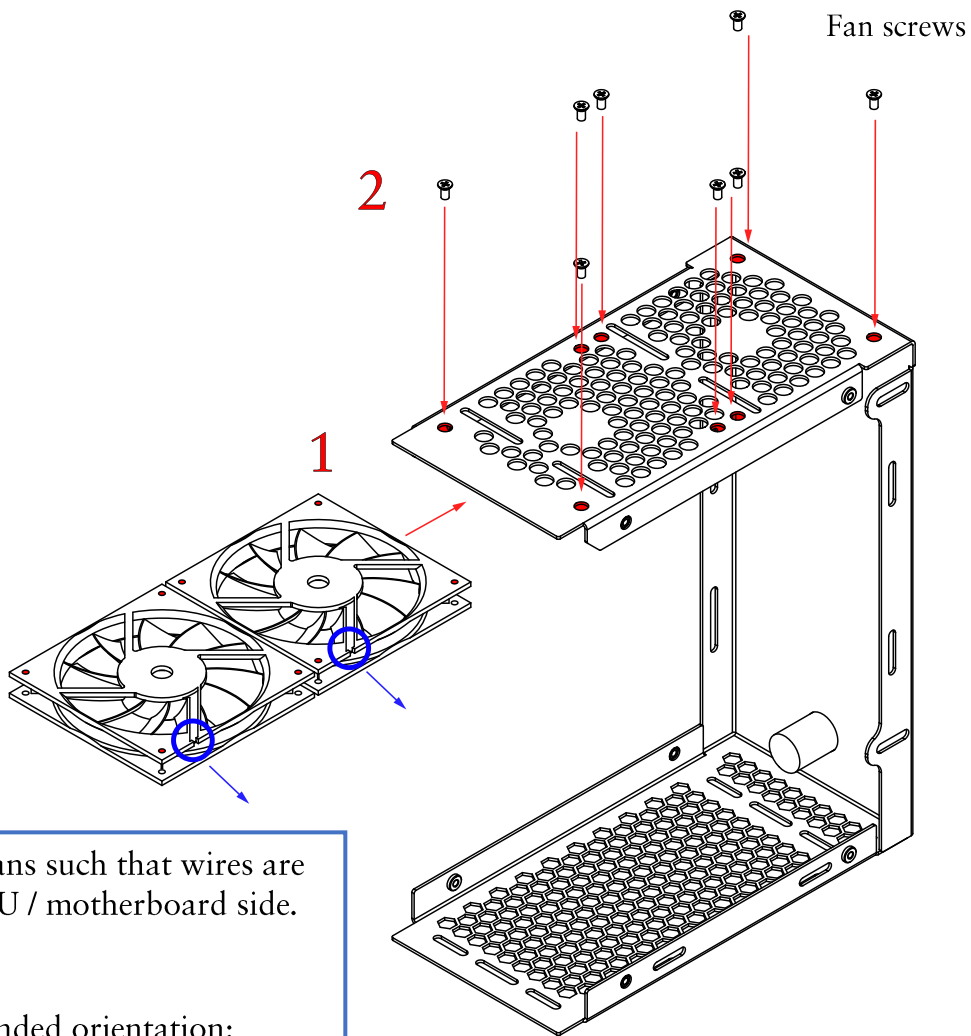

Position fans such that wires are on the CPU / motherboard side.

Recommended orientation: exhaust (sticker on top).

### Connecting Front Shell

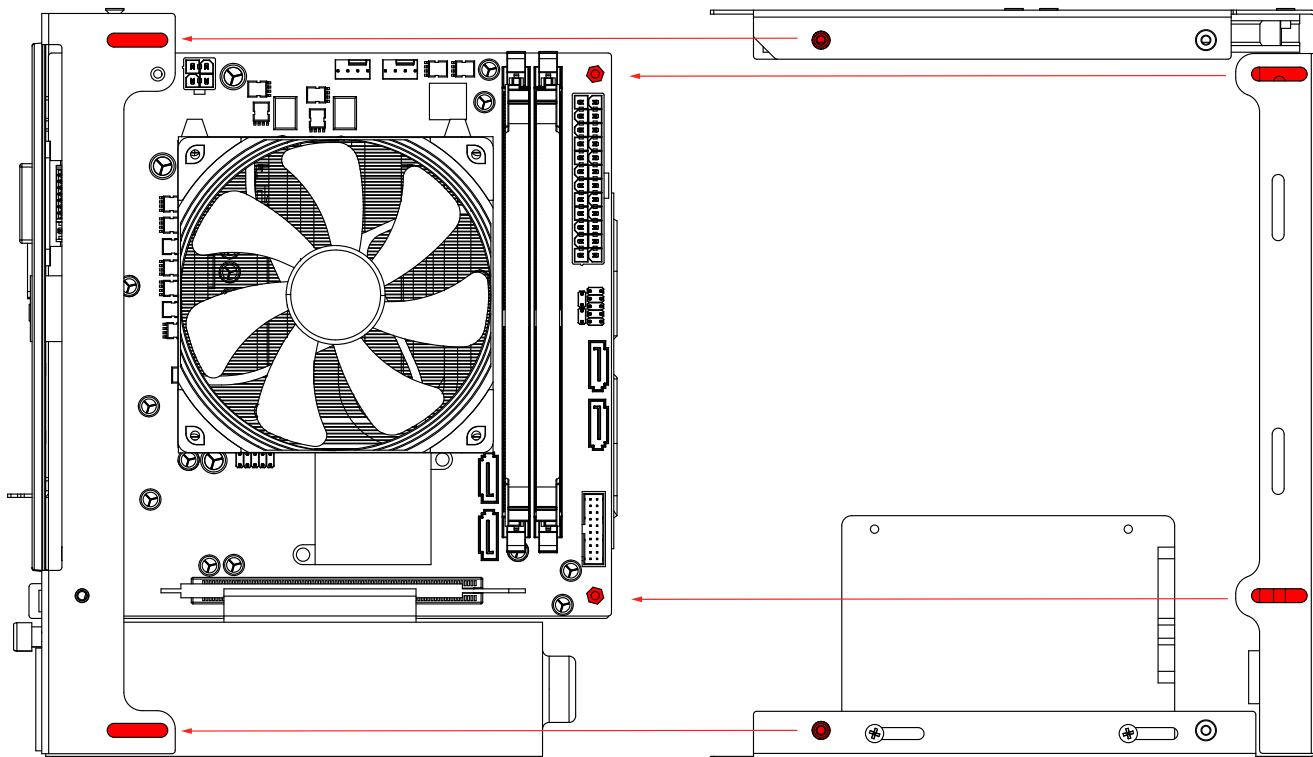

Connect all cables: power button SATA, fans  
Please consult motherboard manual to connect power button

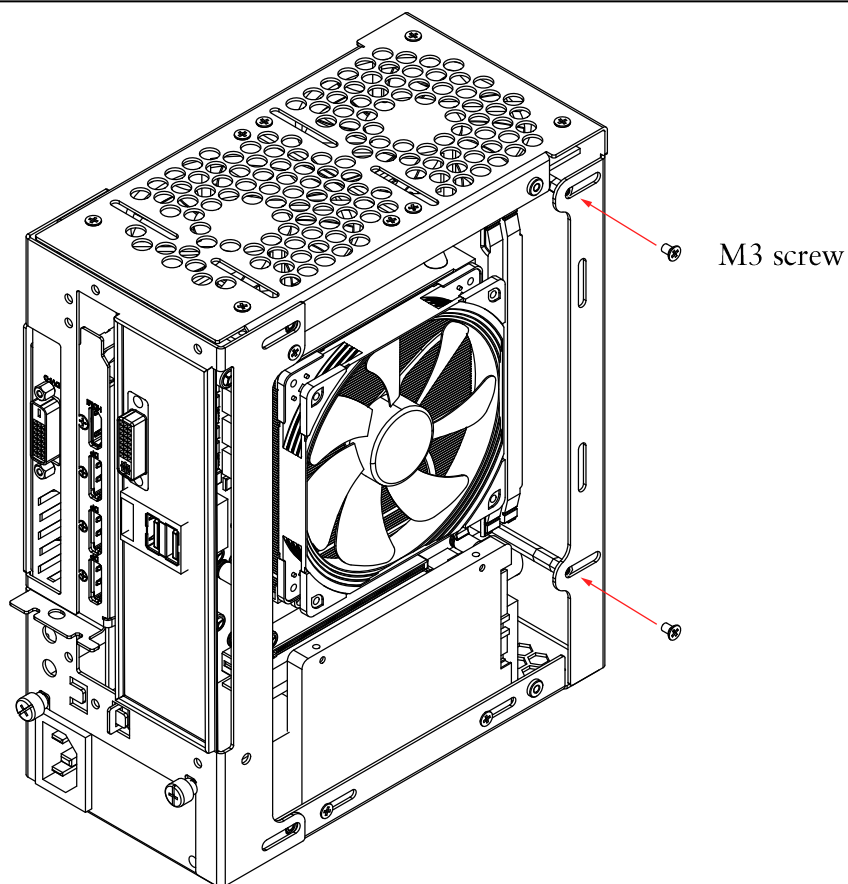



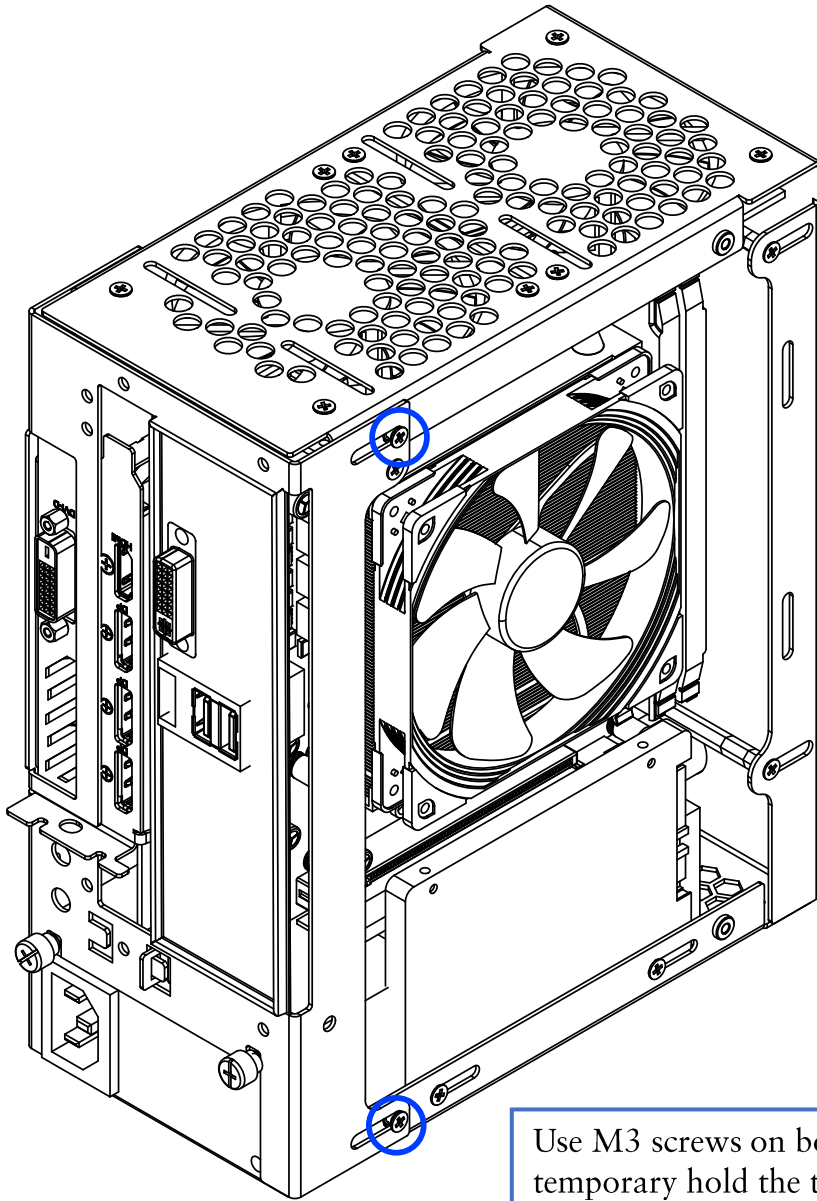

Use M3 screws on both sides to temporary hold the two pieces together. Remove before installing side panels.

# Side Panel Installation

