



# Wireless Headphones

Model: BTH15



User Manual

## Contents

English User Manual	01
Benutzerhandbuch	12
Guide Utilisateur	21
Manual de Usuario	30
Manuale Utente	39
中文说明书	48
取扱説明書	56

## Package Contents



1 x iClever BTH15  
Wireless Headphones



1 x Storage Bag

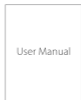

1 x User Manual



1 x 3.5mm Audio Cable



1 x USB Type-C Cable

## Product Diagram

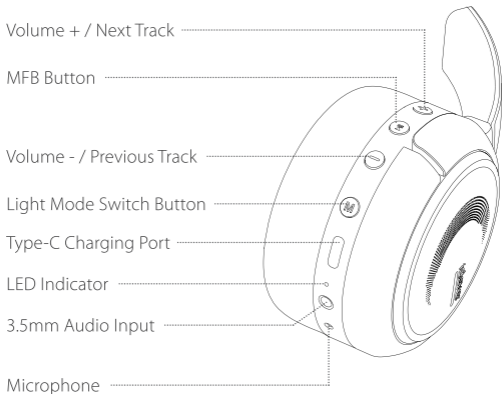

## On / Off

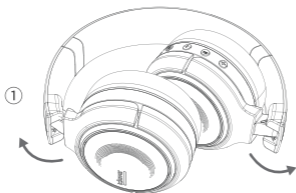



1. If the headphone is folded, just unfold it. Then it will be auto on, the colorful lights will be also on, and the headphone will enter the pairing mode.

- When the headphone is folded as shown below, it will be auto off.

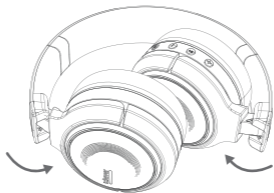

**Note:** If there is an abnormal situation, press and hold the MFB button for 3-5S to turn the headphone on and enter the pairing mode.

## Bluetooth Pairing

- In the power-on state, the colorful lights are on; Bluetooth enters the pairing state, and the red and blue lights flash alternately.

2. Turn on the Bluetooth of the mobile phone. Then find and select the "iClever-BTH15" Bluetooth pairing name in the device list for Bluetooth pairing connection.

## Light Mode Switching

Short press the "Light Mode Switch Button" to turn on/off the light.

## Volume Limit Gear Switching

1. Press and hold the "+" & "-" buttons at the same time to switch the volume limit to the safe volume of 85dB, and the voice broadcast will be "Safe Volume".
2. Press and hold the "+" & "-" buttons at the same time to switch the volume limit to the normal volume mode, and the voice broadcast will be "Normal Volume".



## Operation of Buttons

<b>Volume Up</b>	Short press the "+" button.
<b>Volume Down</b>	Short press the "-" button.
<b>Next Track</b>	Press and hold the "+" button for 2 seconds.
<b>Previous Track</b>	Press and hold the "-" button for 2 seconds.
<b>Play / Pause</b>	Press the MFB button once.
<b>Answer / End A Call</b>	Press the MFB button once.
<b>Reject A Call</b>	Keep pressing the MFB button for seconds.
<b>Activate Siri</b>	Press the MFB button twice.

<b>Clear The Pairing List</b>	After the Bluetooth is turned on, in any state, press and hold the "multi-function button" and "-" button at the same time for 5 seconds to clear the pairing list in the headphone.
-------------------------------	--

## Voice Prompt

<b>Power On</b>	Power on
<b>Power Off</b>	Power off
<b>Pairing</b>	Pairing
<b>Successful Pairing</b>	Connected
<b>Disconnection</b>	Disconnected
<b>Low Power</b>	Battery Low

## Specification

Frequency band	2.4GHz~2.482GHz
Maximum transmission power	4dBm

## How to Charge the Headphone

Connect the Type-C cable to the Type-C port on the headphone, and a 5V power outlet (power adapter is not included). The indicator light will glow red to indicate charging. When the headphone is fully charged, the indicator light will change from red to blue.

## FCC Statement

Changes or modifications not expressly approved by the party responsible for compliance could void the user's authority to operate the equipment.

This equipment has been tested and found to comply with the limits for a Class B digital device, pursuant to Part 15 of the FCC Rules. These limits are designed to provide reasonable protection against harmful interference in a residential installation. This equipment generates uses and can radiate radio frequency energy and, if not installed and used in accordance with the instructions, may cause harmful interference to radio communications. However, there is no guarantee that interference will not occur in a particular installation. If this equipment does cause harmful interference to radio or television reception, which can be determined by turning the equipment off and on, the user is encouraged to try to correct the interference by one or more of the following measures:

- Reorient or relocate the receiving antenna.
- Increase the separation between the equipment and receiver.
- Connect the equipment into an outlet on a circuit different from that to which the receiver is connected.
- Consult the dealer or an experienced radio/TV technician for help.

This device complies with part 15 of the FCC rules. Operation is subject to the following two conditions

- (1) This device may not cause harmful interference.
- (2) This device must accept any interference received, including interference that may cause undesired operation.

## IC Caution

This device complies with Industry Canada licence-exempt RSS standard(s).

Operation is subject to the following two conditions: (1) This device may not cause interference, and (2) This device must accept any interference, including interference that may cause undesired operation of the device.

Le présent appareil est conforme aux CNR d'Industrie Canada applicables aux appareils radio exempts de licence. L'exploitation est autorisée aux deux conditions suivantes: (1) l'appareil ne doit pas produire de brouillage, et (2) l'utilisateur de l'appareil doit accepter tout brouillage radioélectrique subi, même si le brouillage est susceptible d'en compromettre le fonctionnement.

## Packungsinhalt



1 x iClever BTH15  
Funkkopfhörer



1 x Aufbewahrungstasche

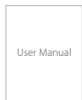

1 x Benutzerhandbuch



1 x 3,5mm-Audiokabel



1 x USB Kabel, Typ C

# Produktbilder

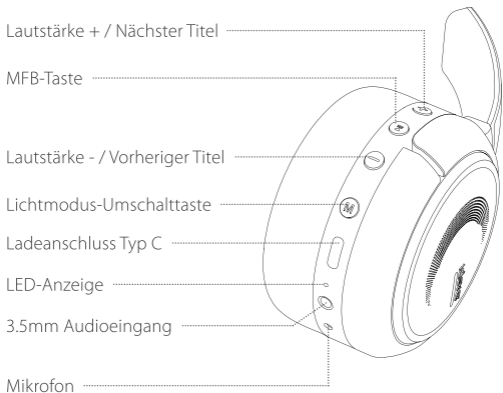

## Ein / Aus

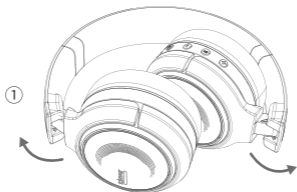





1. Ist der Kopfhörer zusammengeklappt, klappen Sie ihn einfach auseinander. Dann schaltet er sich automatisch ein, die bunten Lichter leuchten und der Kopfhörer geht in den Kopplungsmodus.

2. Ist der Kopfhörer zusammengeklappt, wie unten gezeigt, schaltet er sich automatisch aus.

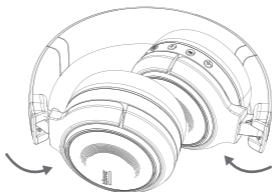

**Hinweis:** Liegt eine abnormale Situation vor, halten Sie die MFB-Taste 3-5 Sekunden lang gedrückt, um den Kopfhörer einzuschalten und den Kopplungsmodus aufzurufen.

## Bluetooth-Kopplung

1. Ist der Kopfhörer eingeschaltet, leuchten die bunten Lichter; Bluetooth geht in den Kopplungszustand über, und die roten und blauen Lichter blinken abwechselnd.

2. Schalten Sie das Bluetooth des Mobiltelefons ein. Suchen Sie dann den Bluetooth-Kopplungsnamen "iClever-BTH15" in der Geräteliste und wählen Sie ihn für die Bluetooth-Kopplungsverbindung aus.

## Umschalten des Lichtmodus

Drücken Sie kurz die "Lichtmodus-Umschalttaste", um das Licht ein-/auszuschalten.

## Umschalten der Lautstärkebegrenzung

1. Halten Sie die Tasten "+" und "-" gleichzeitig gedrückt, um die Lautstärkebegrenzung auf die sichere Lautstärke von 85 dB umzuschalten. Die Sprachübertragung erfolgt in „sicherer Lautstärke“.
2. Halten Sie die Tasten "+" und "-" gleichzeitig gedrückt, um die Lautstärkebegrenzung auf die normale Lautstärke umzuschalten, und die Sprachübertragung erfolgt in "normaler Lautstärke".

## Bedienung der Tasten

<b>Lautstärke erhöhen</b>	Kurz die Taste "+" drücken
<b>Lautstärke senken</b>	Kurz die Taste "-" drücken
<b>Nächster Titel</b>	Halten Sie die Taste "+" 2 Sekunden lang gedrückt
<b>Vorheriger Titel</b>	Halten Sie die Taste "-" 2 Sekunden lang gedrückt
<b>Wiedergabe / Pause</b>	Drücken Sie die MFB-Taste ein Mal
<b>Anruf annehmen / beenden</b>	Drücken Sie die MFB-Taste ein Mal
<b>Anruf abweisen</b>	Halten Sie die MFB-Taste für Sekunden gedrückt
<b>Siri aktivieren</b>	Drücken Sie die MFB-Taste zwei Mal

<b>Kopplungsliste löschen</b>	Halten Sie nach dem Einschalten von Bluetooth in jedem Zustand die "Multifunktionstaste" und die Taste "-" gleichzeitig 5 Sekunden lang gedrückt, um die Kopplungsliste im Kopfhörer zu löschen
-------------------------------	---

## Sprachansage

Einschalten	Einschalten
Ausschalten	Ausschalten
Kopplung	Kopplung
Erfolgreiche Kopplung	Verbunden
Unterbrechung	Getrennt
Niedrige Leistung	Niedriger Batteriestand

## Spezifikation

<b>Begrenzung des Bandes</b>	2.4GHz~2.482GHz
<b>Maximale Übertragungsleistung</b>	4dBm

## So laden Sie den Kopfhörer auf

Verbinden Sie das Kabel Typ C mit dem Ladeanschluss Typ C des Kopfhörers und einer 5V-Steckdose (Netzteil ist nicht im Lieferumfang enthalten). Die Anzeigeleuchte leuchtet rot, um den Ladevorgang anzuzeigen. Ist der Kopfhörer vollständig aufgeladen, wechselt die Anzeigeleuchte von Rot zu Blau.

## Contenu du colis



1 x Écouteurs sans fil  
iClever BTH15



1 x Sac de rangement

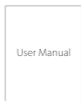

1 x Manuel d'utilisation



1 x Câble audio 3,5 mm



1 x Câble USB Type-C

## Schéma du produit

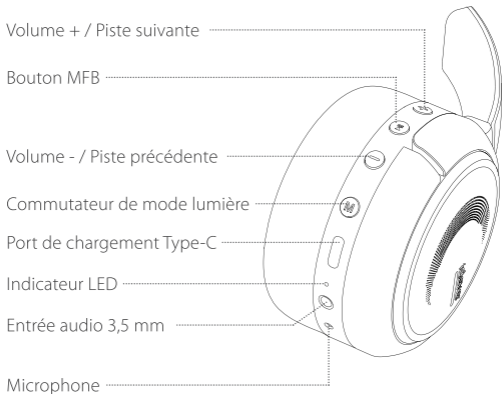



## Marche / Arrêt

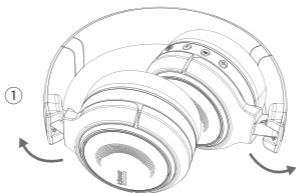



1. Si les écouteurs sont pliés, il suffit de les déplier. Ensuite, ils s'allument automatiquement, les lumières colorées s'allument également et les écouteurs passent en mode de connexion.

2. Lorsque les écouteurs sont pliés comme indiqué ci-dessous, ils s'éteignent automatiquement.

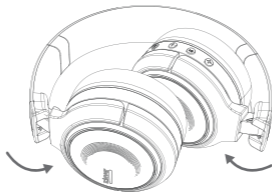

**Note:** En cas de situation anormale, appuyez sur le bouton MFB pendant 3 à 5 secondes pour allumer les écouteurs et passer en mode de connexion.

## Connexion Bluetooth

1. Lors de l'allumage, les voyants colorés sont allumés ; le Bluetooth entre dans l'état d'appariement et les voyants rouges et bleus clignotent alternativement.

2. Activez le Bluetooth de votre téléphone portable, puis trouvez et sélectionnez le nom "iClever-BTH15" dans la liste des appareils pour la connexion Bluetooth.

## Commutateur de mode lumière

Appuyez brièvement sur le bouton de commutation du mode d'éclairage pour allumer/éteindre la lumière.

## Contrôle du système de limitation du volume

1. Appuyez et maintenez enfoncés les boutons "+" et "-" en même temps pour modifier la limite de volume au niveau sûr de 85dB, le message vocal sera " Safe Volume ".
2. Appuyez sur les boutons "+" et "-" en même temps et maintenez-les enfoncés pour changer la limite de volume en mode de volume normal, le message vocal sera " Normal Volume ".

## Fonctionnement des touches

<b>Augmenter le volume</b>	Appuyez brièvement sur le bouton "+".
<b>Réduire le volume</b>	Appuyez brièvement sur le bouton "-".
<b>Piste suivante</b>	Appuyez sur le bouton "+" et maintenez-le enfoncé pendant 2 secondes.
<b>Piste précédente</b>	Appuyez sur le bouton "-" et maintenez-le enfoncé pendant 2 secondes.
<b>Lecture / Pause</b>	Appuyez une fois sur le bouton MFB.
<b>Répondre / Terminer un appel</b>	Appuyez une fois sur le bouton MFB.
<b>Rejeter un appel</b>	Appuyez sur le bouton MFB et maintenez-le enfoncé pendant plusieurs secondes.

<b>Activez Siri</b>	Appuyez deux fois sur le bouton MFB.
<b>Effacer la liste de connexion</b>	Après l'activation du Bluetooth, dans n'importe quel état, appuyez simultanément sur le bouton multifonction et le bouton "-" pendant 5 secondes pour effacer la liste d'appariement des écouteurs.

## Messages vocaux

<b>Allumage</b>	Power on
<b>Arrêt</b>	Power off
<b>Connexion</b>	Pairing
<b>Connexion réussie</b>	Connected

<b>Déconnexion</b>	Disconnected
<b>Batterie faible</b>	Battery Low

## Spécifications

<b>Gamme de fréquences</b>	2.4GHz~2.482GHz
<b>Puissance de transmission maximale</b>	4dBm

## Comment recharger les écouteurs

Connectez le câble Type-C au port Type-C des écouteurs et à une prise de courant 5V (adaptateur électrique non inclus). Le témoin lumineux s'allume en rouge pour indiquer le chargement. Lorsque les écouteurs sont complètement chargés, le témoin lumineux passe du rouge au bleu.

## Contenido del paquete



1 x Auriculares inalámbricos  
iClever BTH15



1 x Bolsa de almacenamiento

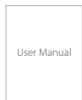

1 x Manual de usuario



1 x Cable de audio de 3,5 mm



1 x Cable USB tipo C



## Diagrama del producto



## Encendido / Apagado

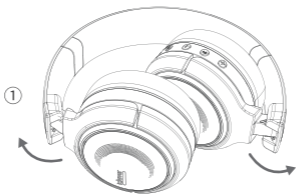



1. Si los auriculares están doblados, simplemente despliéguelos. Entonces se encenderán automáticamente, las luces de colores también se encenderán y los auriculares entrarán en el modo de emparejamiento.

2. Cuando los auriculares estén plegados como se muestra a continuación, se apagarán automáticamente.

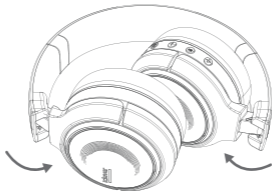

**Nota:** Si hay una situación anormal, mantenga presionado el botón MFB durante 3-5 segundos para encender los auriculares y entrar al modo de emparejamiento.

## Emparejamiento Bluetooth

1. Con los auriculares y las luces de colores encendidas; el Bluetooth entra en estado de emparejamiento y las luces roja y azul parpadean alternativamente.

2. Encienda el Bluetooth del teléfono móvil. A continuación, busque y seleccione el nombre de emparejamiento Bluetooth "iClever-BTH15" en la lista de dispositivos para la conexión.

## Cambio de modo de luz

Presione brevemente el "Botón interruptor de modo de luz" para encender / apagar la luz.

## Cambio de límite de volumen

1. Mantenga presionados los botones "+" y "-" al mismo tiempo para cambiar el límite de volumen a un volumen seguro de 85dB, y la voz dirá "Safe volume".
2. Mantenga presionados los botones "+" y "-" al mismo tiempo para cambiar el límite de volumen al modo de volumen normal, y la voz dirá "Normal volume".

## Uso de los botones

<b>Subir volumen</b>	Presione brevemente el botón "+".
<b>Subir volumen</b>	Presione brevemente el botón "-".
<b>Siguiente pista</b>	Mantenga presionado el botón "+" durante 2 segundos.
<b>Pista anterior</b>	Mantenga presionado el botón "-" durante 2 segundos.
<b>Play / Pausa</b>	Presione el botón MFB una vez.
<b>Responder / finalizar una llamada</b>	Presione el botón MFB una vez.
<b>Rechazar una llamada</b>	Mantenga presionado el botón MFB durante unos segundos.
<b>Activar Siri</b>	Presione el botón MFB dos veces.

**Borrar la lista de emparejamientos**

Una vez que el Bluetooth esté encendido, en cualquier estado, presione y mantenga presionado el "botón multifunción" y el botón "-" al mismo tiempo durante 5 segundos para borrar la lista de emparejamiento en los auriculares.

## Mensajes de voz

<b>Encendido</b>	Encendido
<b>Apagado</b>	Apagado
<b>Emparejamiento</b>	Emparejamiento
<b>Emparejamiento exitoso</b>	Conectado
<b>Desconexión</b>	Desconectado
<b>Batería baja</b>	Batería baja

## Especificaciones

<b>Rango de frecuencia</b>	2.4GHz~2.482GHz
<b>Potencia máxima de transmisión</b>	4dBm

## Cómo cargar los auriculares

Conecte el cable tipo C al puerto tipo C de los auriculares y a una toma de corriente de 5 V (el adaptador de corriente no está incluido). La luz indicadora se iluminará en rojo para indicar que se está cargando. Cuando los auriculares estén completamente cargados, la luz indicadora cambiará de rojo a azul.



## Contenuto del pacco



1 x Cuffie senza fili  
iClever BTH15



1 x Custodia



1 x Manuale d'uso



1 x Cavo audio da 3,5 mm



1 x Cavo USB Tipo-C

## Illustrazione del prodotto



## On / Off

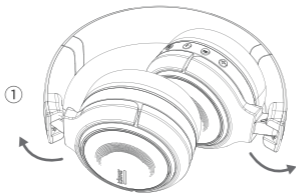



1. Se le cuffie sono piegate, basta aprirle. Quindi si accenderanno automaticamente, anche le luci colorate saranno attive, e le cuffie entreranno in modalità di connessione.

2. Quando le cuffie sono piegate come mostrato qui sotto, si spengono automaticamente.

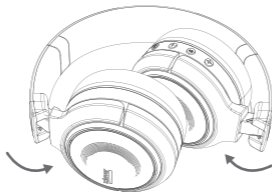

**Nota:** Se c'è una situazione anomala, tenere premuto il pulsante MFB per 3-5 secondi per accendere le cuffie ed entrare nella modalità di collegamento.

## Connessione Bluetooth

1. In fase di accensione, le luci colorate sono accese; il Bluetooth entra nello stato di collegamento e le luci rossa e blu lampeggiano alternandosi.

2. Attivare il Bluetooth del cellulare, quindi trovare e selezionare il nome "iClever-BTH15" nell'elenco dei dispositivi per la connessione Bluetooth.

## Interruttore della modalità luce

Premere brevemente sul " Pulsante di commutazione della modalità luce " per accendere/spegnere la luce.

## Comando del meccanismo di limitazione del volume

1. Tenere premuti i pulsanti "+" e "-" allo stesso tempo per passare il limite del volume al livello di sicurezza di 85dB, il messaggio vocale sarà "Safe Volume".
2. Tenere premuti contemporaneamente i pulsanti "+" e "-" per passare il limite del volume alla modalità di volume normale, il messaggio vocale sarà "Normal Volume".

## Funzionamento dei tasti

<b>Volume su</b>	Premere brevemente il pulsante "+".
<b>Volume giù</b>	Premere brevemente il pulsante "-".
<b>Traccia successiva</b>	Tenere premuto il pulsante "+" per 2 secondi.
<b>Traccia precedente</b>	Tenere premuto il pulsante "-" per 2 secondi.
<b>Riproduzione / Pausa</b>	Premere una volta il pulsante MFB.
<b>Rispondere / terminare una chiamata</b>	remere una volta il pulsante MFB.
<b>Rifiutare una chiamata</b>	Tenere premuto il pulsante MFB per alcuni secondi.

<b>Attivare Siri</b>	Premere il pulsante MFB due volte.
<b>Cancellare l'elenco di collegamento Bluetooth</b>	Dopo l'attivazione del Bluetooth, in qualsiasi stato, tenere premuto il "multi-function button" (pulsante multifunzione) e il pulsante "-" allo stesso tempo per 5 secondi per cancellare l'elenco di collegamento delle cuffie.

## Messaggio vocale

<b>Accensione</b>	Power on
<b>Spegnimento</b>	Power off
<b>Collegamento</b>	Pairing
<b>Collegamento riuscito</b>	Connected



<b>Disconnessione</b>	Disconnected
<b>Batteria scarica</b>	Battery Low

## Specifiche

<b>limite di banda</b>	2.4GHz~2.482GHz
<b>Potenza massima di trasmissione</b>	4dBm

## Come ricaricare le cuffie

Collegare il cavo Tipo-C alla porta Tipo-C delle cuffie e a una presa di corrente da 5V (l'adattatore di corrente non è incluso). L'indicatore luminoso si illuminerà di rosso per indicare la ricarica. Quando le cuffie sono completamente cariche, l'indicatore luminoso passa dal rosso al blu.

## 包装清单



1 x iClever BTH15  
蓝牙耳机



1 x 收纳包

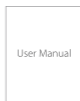

1 x 说明书



1 x 3.5mm 音频线



1 x Type-C 充电线

## 产品示意图

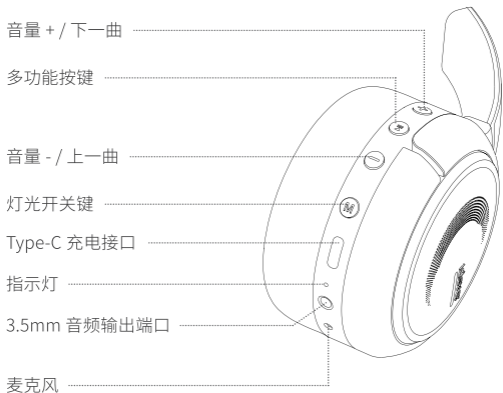

## 开 / 关机

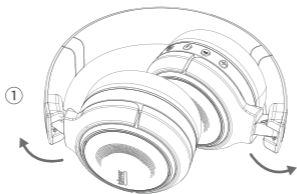



1. 当你收到耳机是折叠状态，展开耳机，即自动开机，七彩灯亮，耳机进入配对模式。

2. 耳机折叠如下图状态，即自动关机。

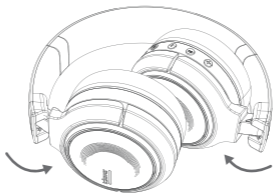

**备注：**假如出现异常情况，可以长按 MFB 键 3-5S，开机并进入配对模式。

## 蓝牙配对

1. 在开机状态下，七彩灯亮，蓝牙进入配对状态，红蓝灯交替闪烁。
2. 打开手机蓝牙，在设备列表中，查找并选择“iClever-BTH15”蓝牙配对名称进行蓝牙配对连接。

## 灯关开关键

短按灯关开关键，可以打开或者关闭灯光

## 音量限制开关

1. 同时按住“+” & “-” 按键，音量限制切换到 85dB, 语音播报为“Safe Volume”
2. 同时按住“+” & “-” 按键，音量限制切换到正常模式，语音播报为“Normal Volume”

## 按键功能

音量加	短按“+” 按键
音量减	短按“-” 按键

下一曲	长按“+”按键 2 秒
上一曲	长按“-”按键 2 秒
播放 / 暂停	短按多功能按键
接听 / 挂断电话	短按多功能按键
拒接电话	长按多功能按键
激活 Siri	双击多功能按键
清除配对列表	同时长按 MFB 键 + 音量减键 4S，满足开机的所有状态下，清除后立刻自动进入配对状态。

## 语音提示

开机	Power on
----	----------



关机	Power off
配对	Pairing
蓝牙连接成功	Connected
蓝牙断连	Disconnected
低电量提醒	Battery Low

## 规格参数

频段范围	2.4GHz~2.482GHz
最大传输功率	4dBm

## 耳机充电

将 Type-C 充电线一端接入 5V 电源适配器 ( 产品不含适配器 ), 另一端接入耳机。充电状态下红灯常亮, 充满电后蓝灯常亮。

## パッケージの内容



iClever BTH15  
ワイヤレスヘッドホン× 1



収納バッグ× 1



取扱説明書× 1



3.5mm オーディオケーブル× 1



USBType-C ケーブル× 1

## 製品図

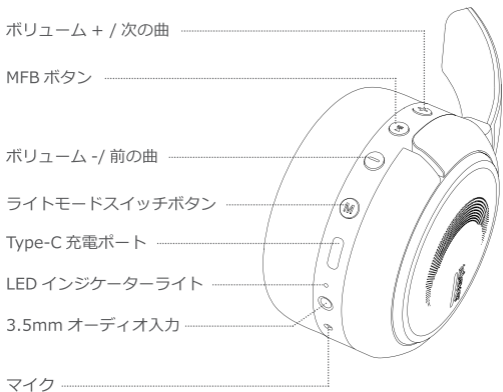

## オン / オフ (図のように)

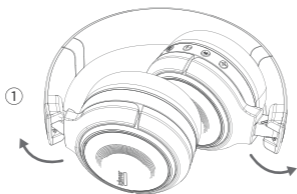



1. 折りたたまれているヘッドホンを広げると、自動的にオンになりカラフルなライトが点灯し、ペアリングモードに入ります。

2. ヘッドホンを下図のように折りたたむと、自動的にオフになります。

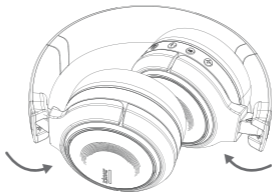

**注意：** 異常が発生した場合は、MFB ボタンを 3～5 秒間押し続けるとヘッドホンの電源が入り、ペアリングモードになります。

## Bluetooth ペアリング

1. 電源オンの状態では、カラフルなライトが点灯します。Bluetooth がペアリングの状態になると、赤と青のライトが交互に点滅します。

2. スマートフォンの Bluetooth をオンにし、Bluetooth ペアリング接続用のデバイスリストで「iClever-BTH15」を選択します。

## ライトモード切り替え

「ライトモードスイッチボタン」を短く押すと、ライトのオン / オフが切り替わります。

## 音量制限切り替え

1. 「+」ボタンと「-」ボタンを同時に押し続けると、音量制限が85dBの安全音量に切り替わり、「Safe Volume」と音声案内があります。
2. 「+」ボタンと「-」ボタンを同時に押し続けると、音量制限が通常の音量モードに切り替わり、「Normal Volume」と音声案内があります。

## ボタン操作

音量を上げる	「+」ボタンを短く押します。
音量を下げる	「-」ボタンを短く押します。
次の曲	「+」ボタンを2秒間押し続けます。
前の曲	「-」ボタンを2秒間押し続けます。
再生 / 一時停止	MFB ボタンを1回押します。
通話に応答 / 終了	MFB ボタンを1回押します。
通話を拒否する	MFB ボタンを数秒間押し続けます。
Siri を起動する	MFB ボタンを2回押します。



**ペアリングリスト  
をクリアする**

Bluetooth をオンにした後、どの状態でも、「MFB ボタン」と「-」ボタンを同時に 5 秒間押し続けると、ヘッドホン内のペアリングリストをクリアすることができます。

## 音声プロンプト

<b>Power On</b>	電源オン
<b>Power Off</b>	電源オフ
<b>Pairing</b>	ペアリング
<b>Successful Pairing</b>	ペアリング完了
<b>Disconnection</b>	切断
<b>Low Power</b>	低電力

## 仕様

周波数帯の範囲	2.4GHz~2.482GHz
最大送信電力	4dBm

## ヘッドホンの充電方法

Type-C ケーブルをヘッドホンの Type-C ポートと 5V 電源コンセントに接続します（電源アダプターは含まれていません）。インジケータライトが赤く点灯し、充電中であることを示します。ヘッドホンが完全に充電されると、インジケータライトが赤から青に変わります。

### ※ご注意：

マイク機能は Bluetooth モードのみ対応します。有線モードでマイクを使用することはできませんのでご了承ください。

また、NintendoSwitch などの Bluetooth マイク入力に非対応のデバイスをご使用の場合は、マイク機能をご使用いただけませんため、予めご注意ください。