



# Birlea

Suppliers of inspiration

Vendor: S000139



## ASSEMBLY INSTRUCTIONS LYNX 2 DOOR COMBI ROBE

**IMPORTANT: READ THESE INSTRUCTIONS CAREFULLY BEFORE ATTEMPTING TO ASSEMBLE OR USE YOUR LYNX 2 DOOR COMBI ROBE.**

**PLEASE KEEP THESE INSTRUCTIONS FOR FUTURE REFERENCE.**

### **ASSEMBLY:**

Assembly should be carried out with this item laying flat, not standing upright.  
Assemble on a soft, clean surface to prevent damages.  
To erase the numbers printed on the pieces, use the rubber into the accessories pack.

### **HEALTH & SAFETY:**

DO NOT use this wardrobe if any parts are missing, damaged or worn.  
DO NOT use this wardrobe unless all fixings are secured.  
Always use on a level, even surface.

### **CARE & MAINTENANCE:**



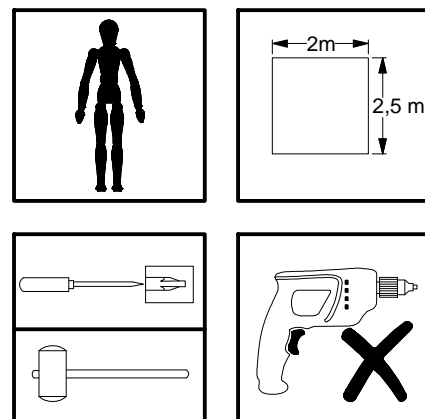
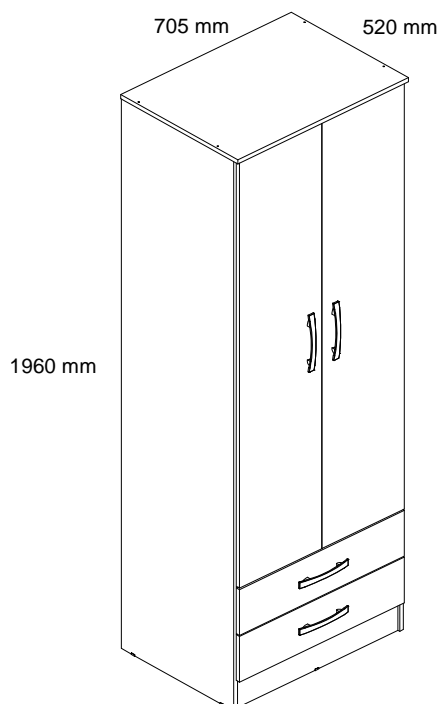



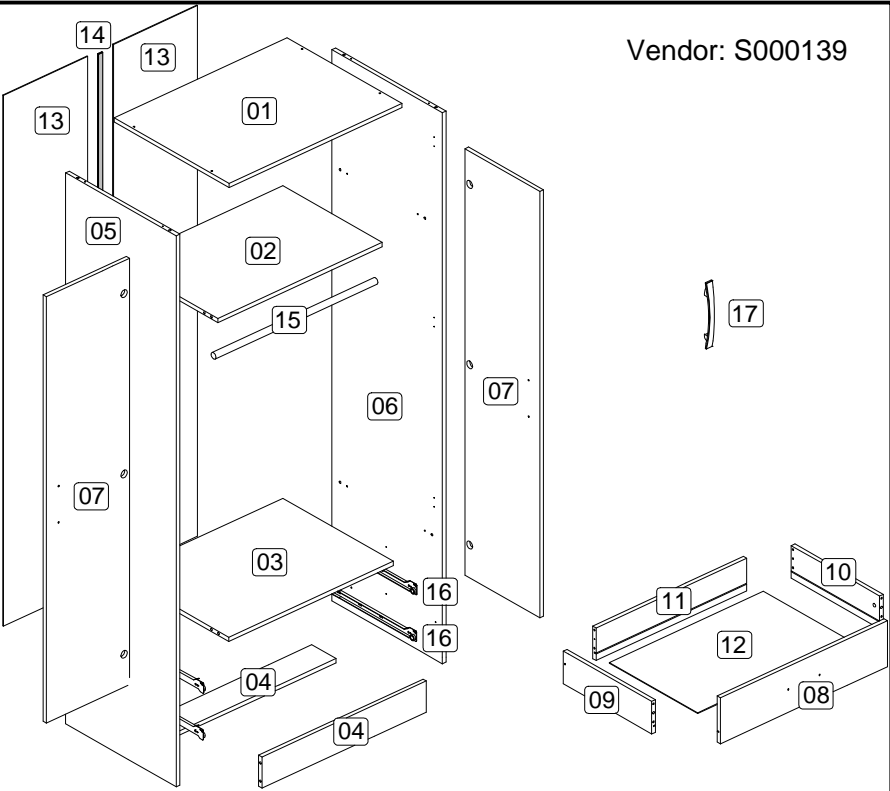



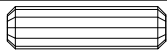

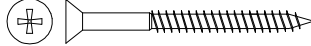
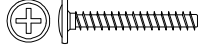
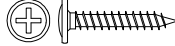
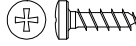

Periodically check all screws & fixings to ensure they are secure.  
DO NOT push the wardrobe as this will cause damage.  
Always lift the wardrobe with two people to reposition.  
Keep any sharp objects away from the wardrobe.



[www.birlea.com](http://www.birlea.com)

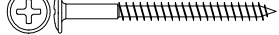

**\*\* You will need a small mallet and a screwdriver for assembly.**  
**\*\* Some screws and wooden dowel may remain.**  
**\*\* Wall plug and screw is not supplied to attach strap to the wall**

Parts List			Hardware List		
Part	Description	Qty	Part	Description	Qty
01	Top Panel	1	A	8 x 30mm Wooden Dowel 	32
02	Shelf	1	C	Simple Minifix Screw 	16
03	Base Panel	1	D	Cam Lock 	16
04	Plinth	2	E	Plastic Cap 	8
05	Left Panel	1	F	4.5 x 45mm Screw 	8
06	Right Panel	1	G	3.5 x 25mm Screw 	8
07	Door	2	H	3 x 20mm Screw 	4
08	Drawer Front	2	I	3.5 x 14mm Screw 	27
09	Left Drawer Panel	2	J	3 x 14mm Screw 	16
10	Right Drawer Panel	2	K	10 x 10mm Tack 	60
11	Drawer Back	2	L	Small Plastic Foot 	5
12	Drawer Base	2	M	Hinge 	6
13	Back Panel	2	N	Hinge Bracket 	6
14	Spine	1	O	Door Limiter 	2
15	Hanging Rail	1	P	Rail Support 	2
16	Drawer Runners	2	Q	Glue 	1
17	Handles	4	R	Strap 	1
			S	Bushing 	1
			T	5 x 60 mm Screw 	1

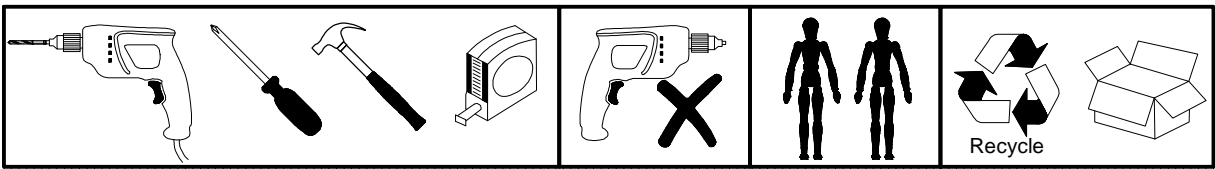

**Step 1:** Prepare these parts for assembly using hardware parts A, C, I, J, M, N, O, and Q.  
**DO NOT** use any power tools as this may damage the frame and will invalidate any claim.

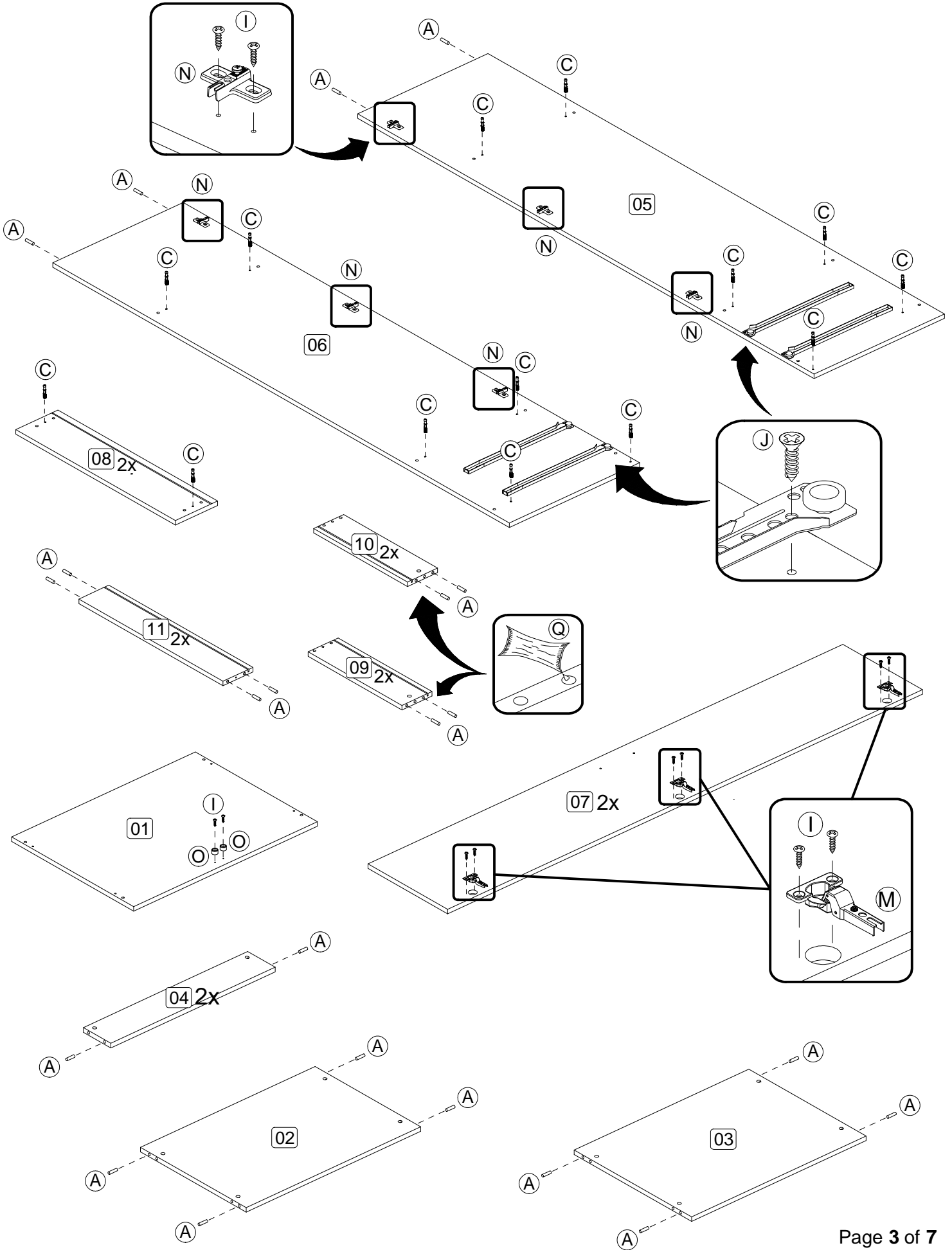

**Step 2:** Attach the left panel (5) to the shelf (2) and base panel (3) using hardware parts D and E with a screwdriver (not provided).

**DO NOT use any power tools as this may damage the frame and will invalidate any claim.**

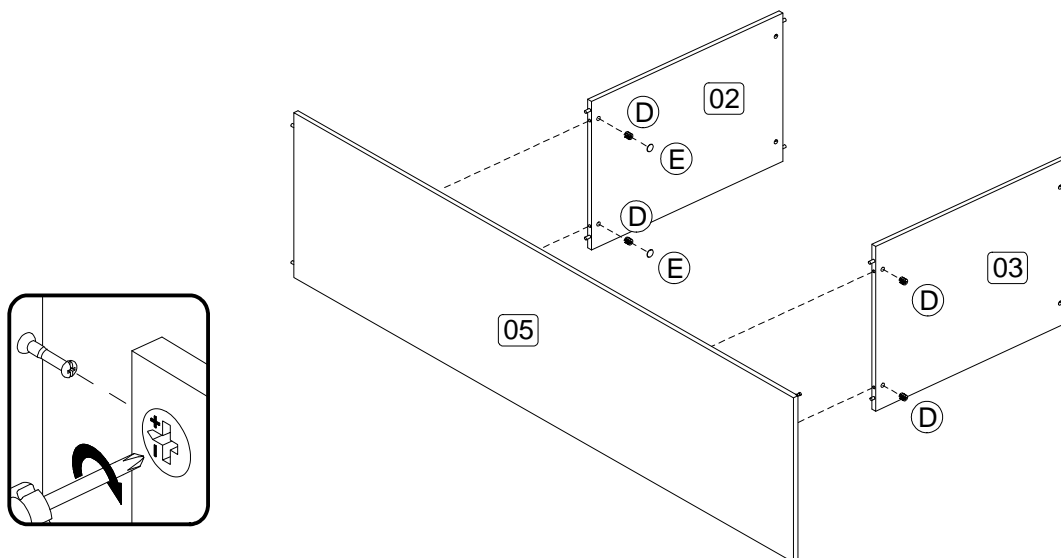

**Step 3:** Attach the plinths (4) to the left panel (5) using hardware parts D and a screwdriver (not provided).

**DO NOT use any power tools as this may damage the frame and will invalidate any claim.**

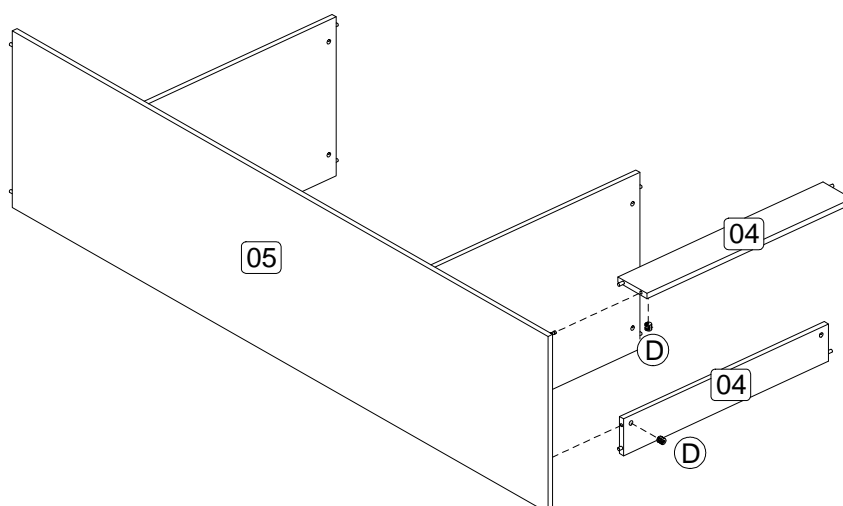

**Step 4:** Attach the right panel (6) to the shelf (2), base panel (3) and plinths (4) using hardware parts D and E with a screwdriver (not provided).

**DO NOT use any power tools as this may damage the frame and will invalidate any claim.**

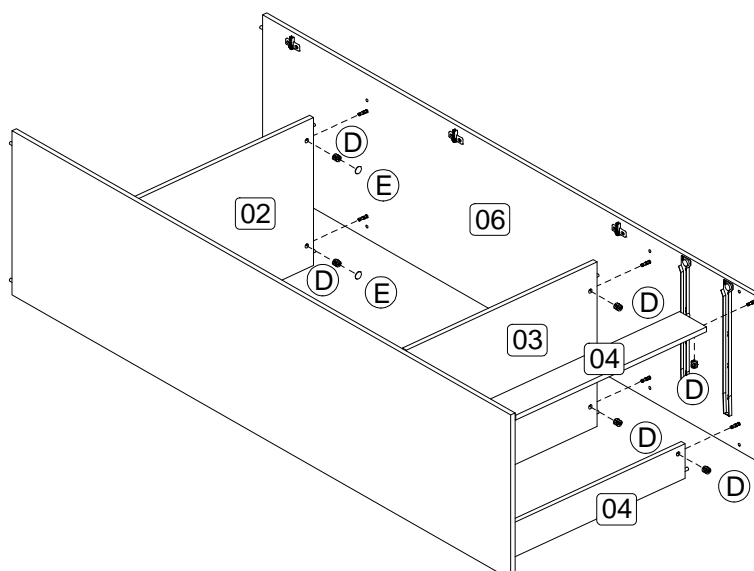

**Step 5:** Attach the top panel (1) using hardware part F and a screwdriver (not provided).  
**DO NOT use any power tools as this may damage the frame and will invalidate any claim.**

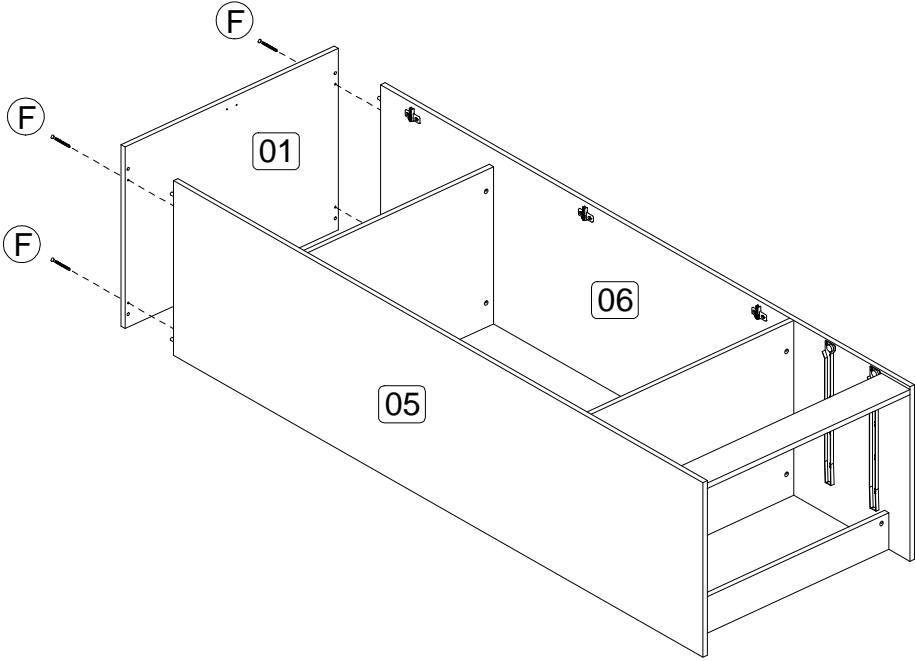

**Step 6:** Attach hardware part P to the side using hardware part H, then attach hardware part L to the base using hardware part K. You will need to use a small mallet and screwdriver (not provided).  
**DO NOT use any power tools as this may damage the frame and will invalidate any claim.**

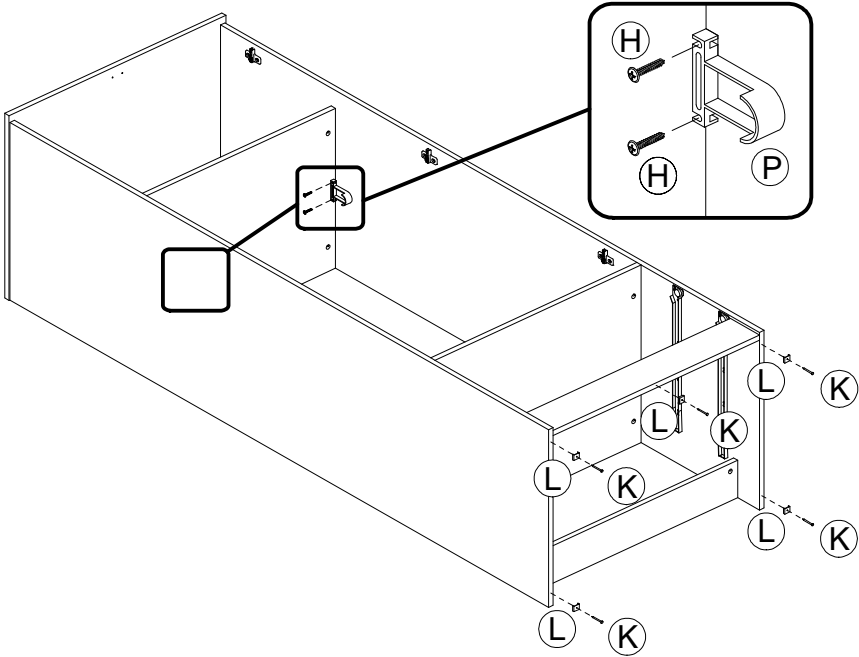

**Step 7:** Connect the back panels (13) with the spine (14) and secure using hardware part K and a small mallet (not provided).  
**DO NOT use any power tools as this may damage the frame and will invalidate any claim.**

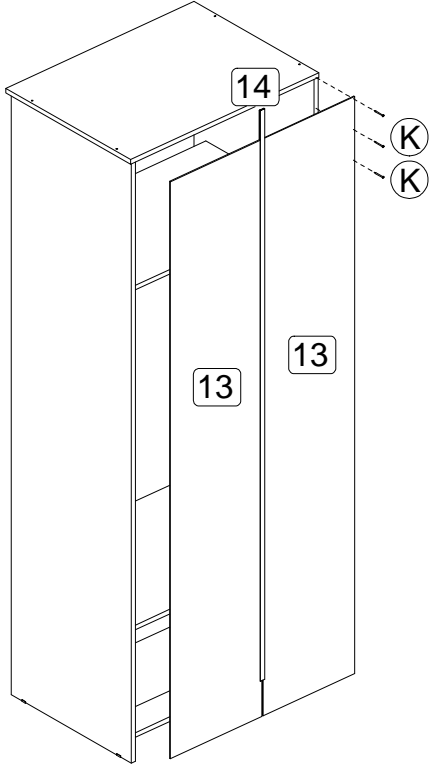

**Step 8:** Assemble the drawer components using hardware parts D, E, F, G, J, and Q.  
**DO NOT use any power tools as this may damage the frame and will invalidate any claim.**

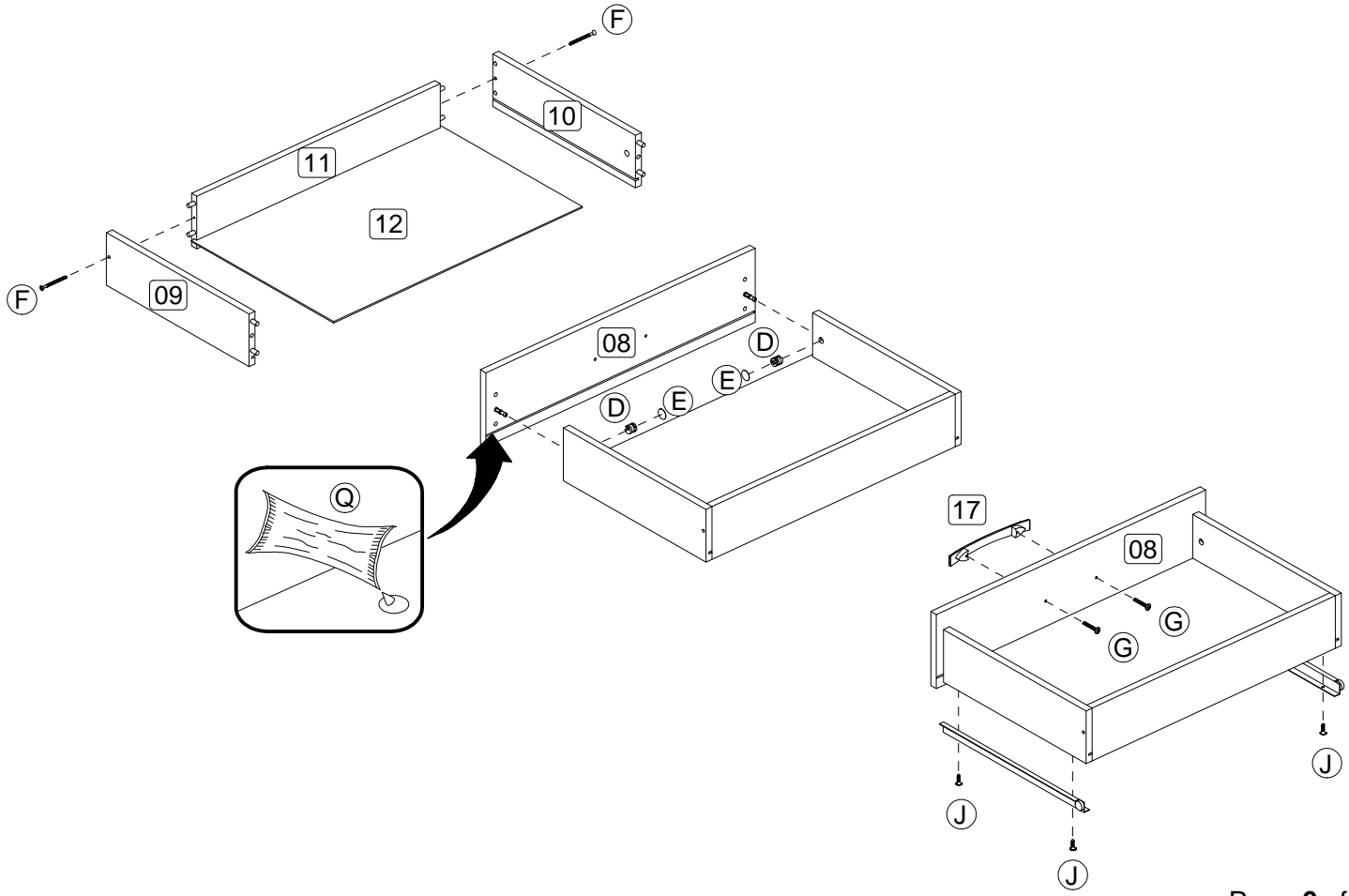

**Step 9:** Insert the hanging rail (15) to the rail supports (P). Attach the doors (7) to the left panel (5) and right panel (6) using hardware parts M and N. Attach the handles (17) to the doors (7) using hardware parts G and a screwdriver (not provided).

**DO NOT use any power tools as this may damage the frame and will invalidate any claim.**

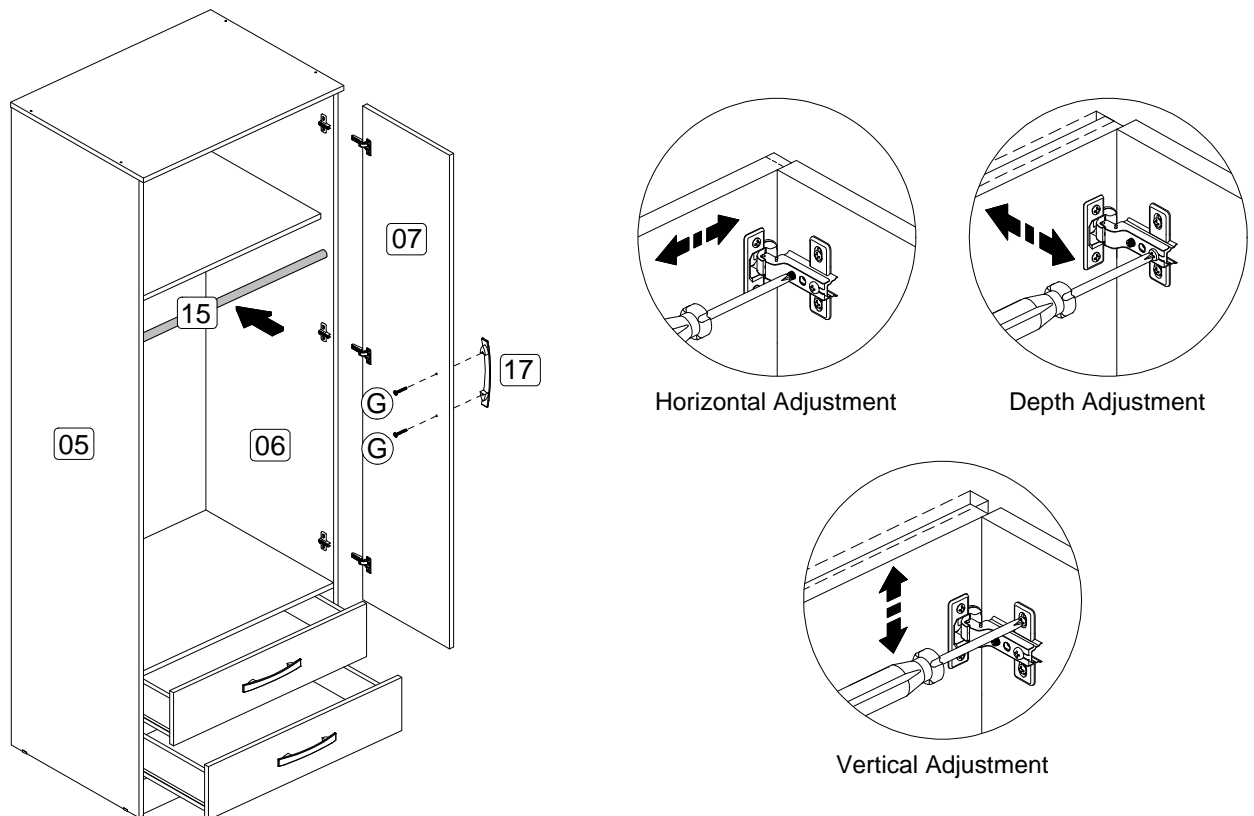

**Step 10:** To secure the item to the wall use hardware parts R, S and T using a screwdriver (not provided). Then attach hardware part I to the item with a screwdriver (not provided).

**DO NOT use any power tools as this may damage the frame and will invalidate any claim.**

**Birlea Furniture advise you use the wall straps provided to further enhance the safety of this product**

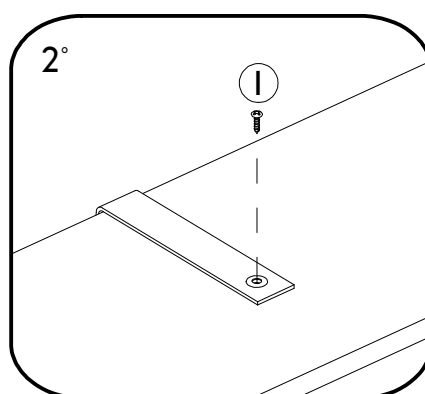
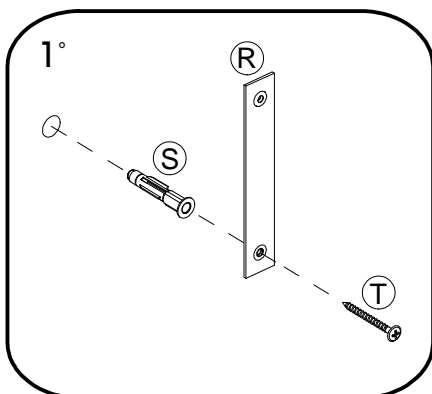

### Additional Information:

- For complete product information, images and dimension diagrams please visit the website [www.birlea.com](http://www.birlea.com)
- If you have any issues with your item please contact the retailer directly you purchased it from who will be able to resolve any issues with Birlea.
- Why don't you send us photos of your assembled furniture to [info@birlea.com](mailto:info@birlea.com) to be shared in our #birleahome feature on Instagram.



**Birlea**  
Suppliers of inspiration