

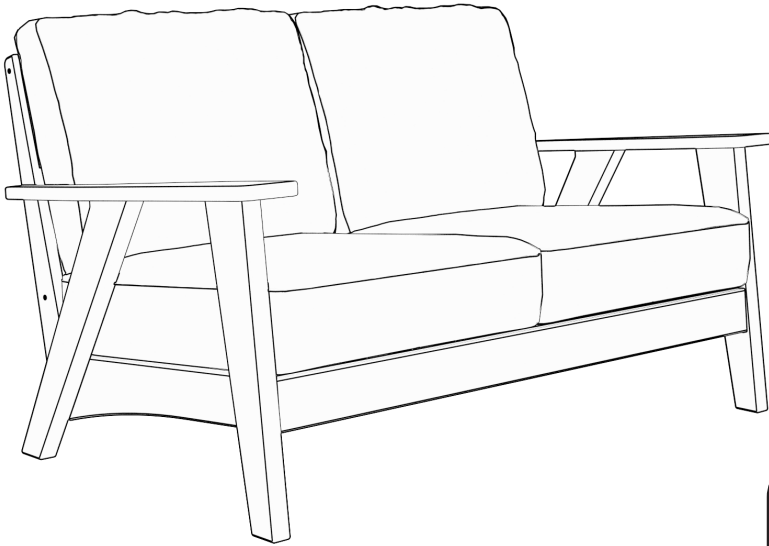

PADDY O'

furniture

Loveseat
PATDCU2000L-FO



Tools Required

- * Drill
- * Philips head driver bit
- * Rubber Mallet

Assembly Tips

- * Perform assembly on a clean, soft surface to prevent parts from being scratched
- * Always start bolts by hand to prevent cross threading
- * If your drill has a clutch set it to medium torq. Once parts are pulled together, add 1/4 to 1/2 turn.

Hardware Included

1 1/2" Bolt

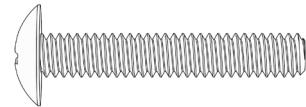

x 12

Parts Included

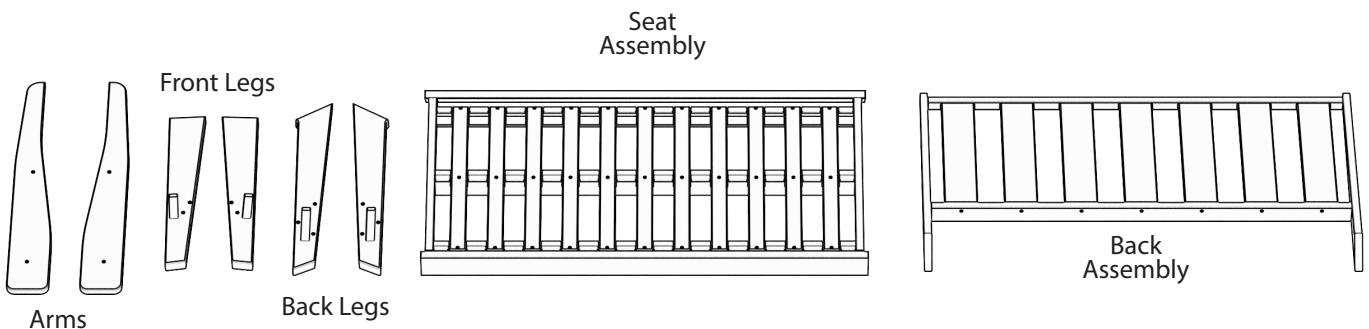

Step 1

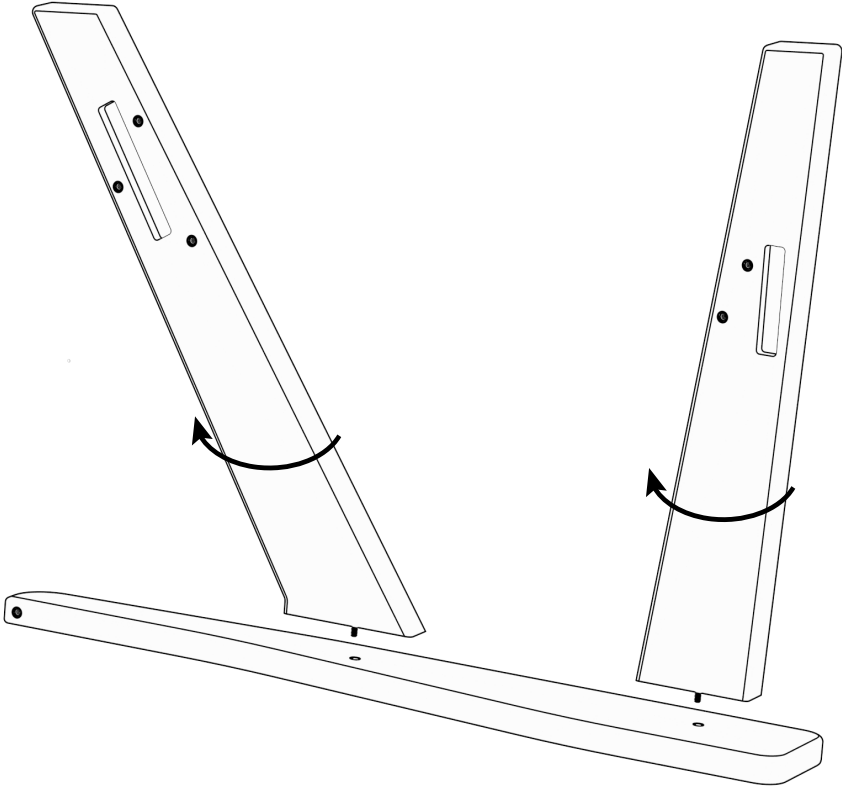

Thread the front and back leg in to the inserts as shown above.
Repeat on the opposite arm and legs.

Step 2

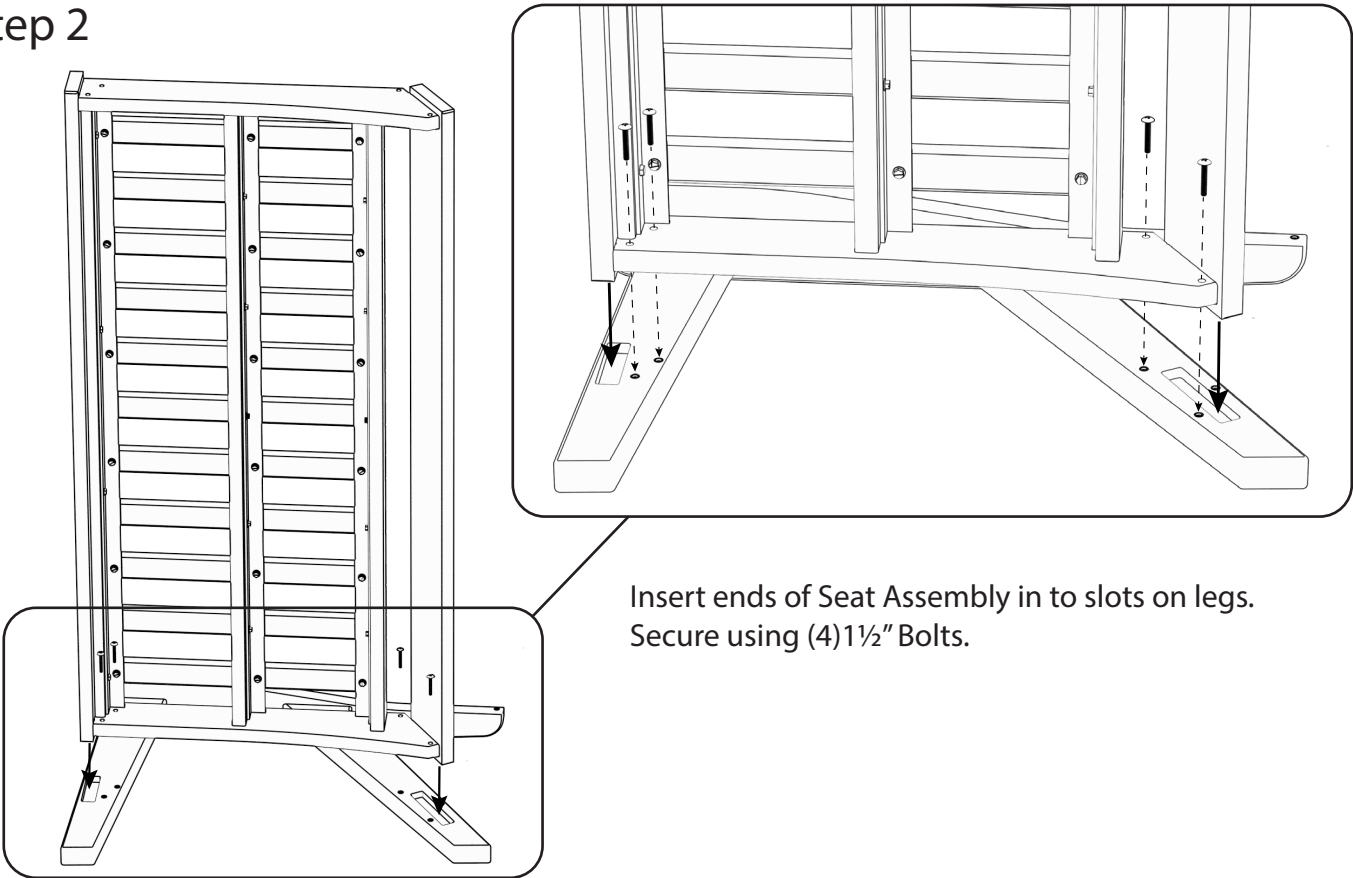

Step 3

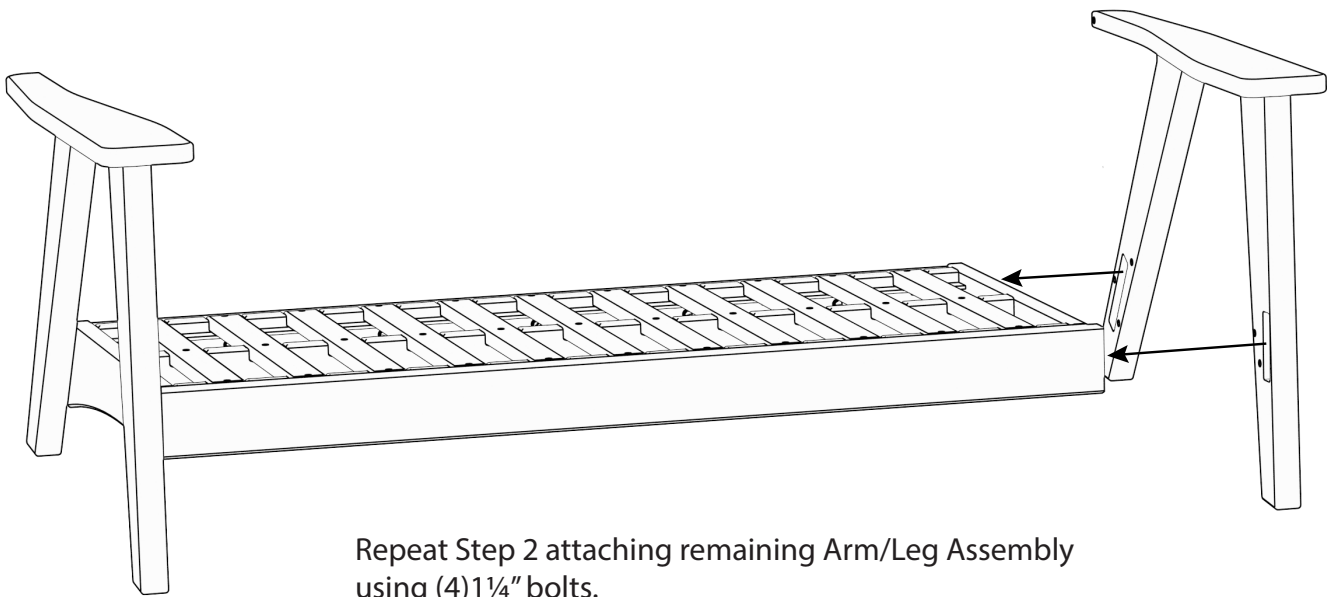

Repeat Step 2 attaching remaining Arm/Leg Assembly using (4) 1¼" bolts.

Step 4

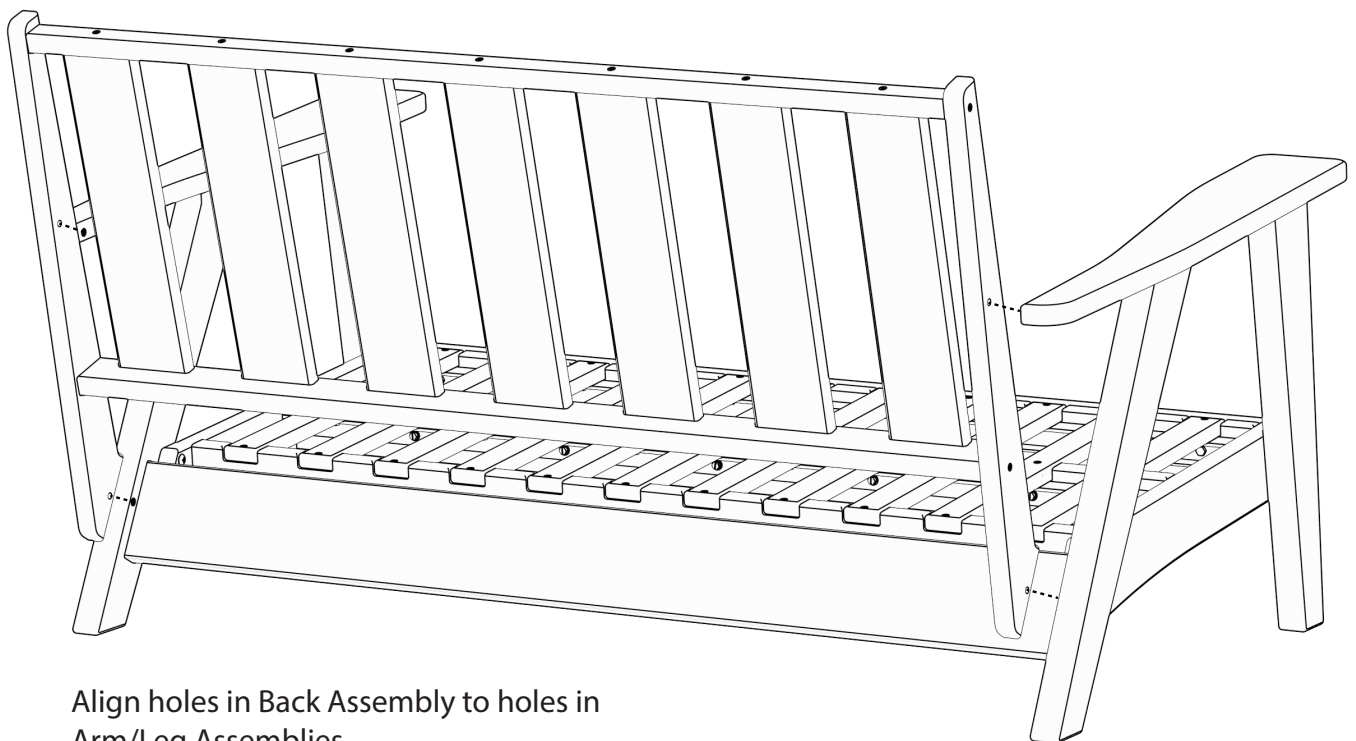

Align holes in Back Assembly to holes in Arm/Leg Assemblies.

Step 5

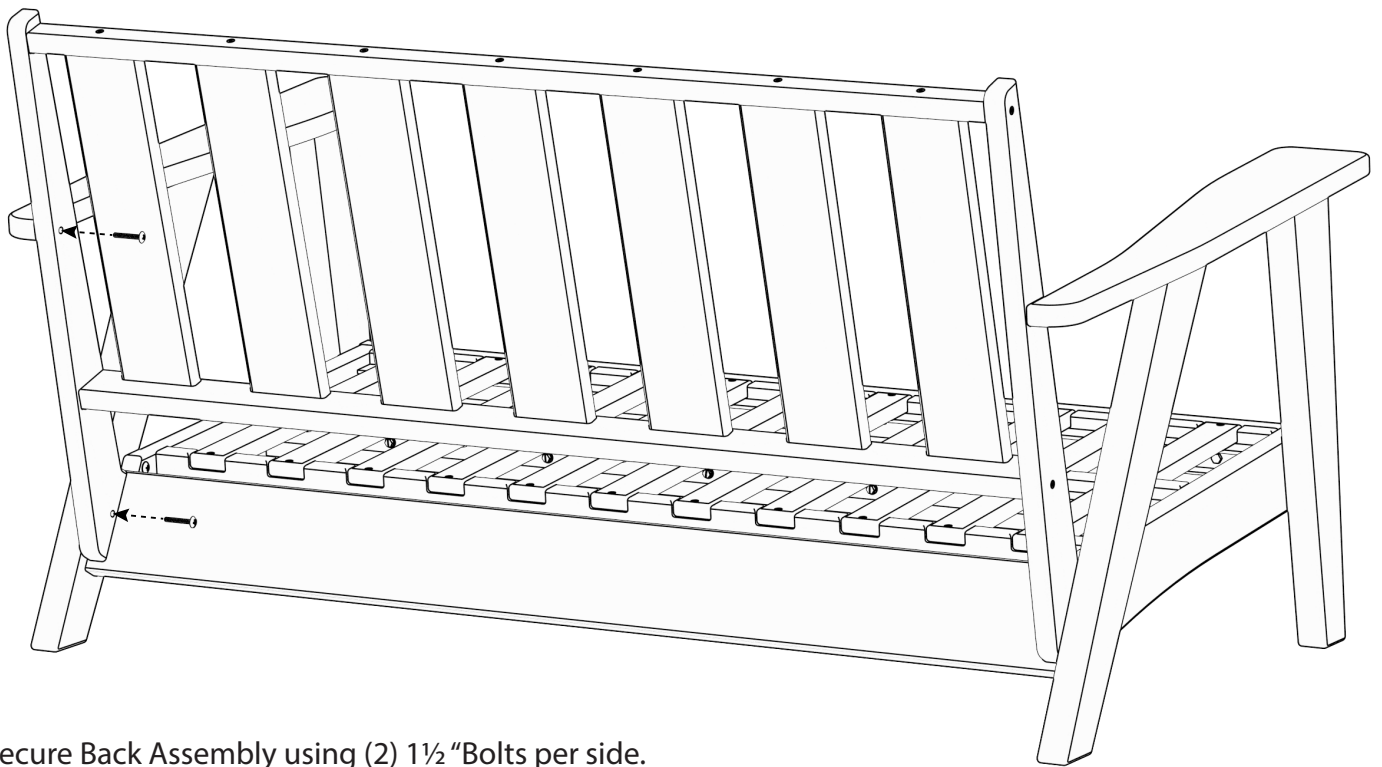

Secure Back Assembly using (2) 1½" Bolts per side.

Step 6

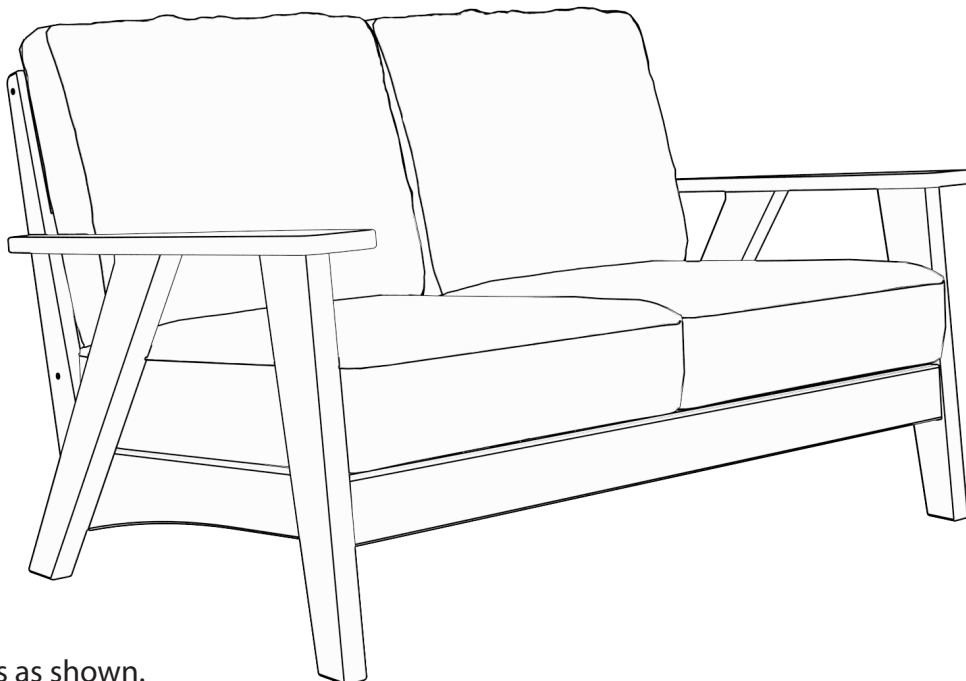

Place Cushions as shown.