



PADDY O'

furniture

Chaise Lounge
PATDSL4000-FO





Tools Required

- * Drill
- * Philips head driver bit
- * Rubber Mallet

Assembly Tips

- * Perform assembly on a clean, soft surface to prevent parts from being scratched
- * Always start bolts by hand to prevent cross threading
- * If your drill has a clutch set it to medium torq. Once parts are pulled together, add 1/4 to 1/2 turn.

Hardware Included

2" Bolt		x 12
1 1/2" Bolt		x 2

Parts Included

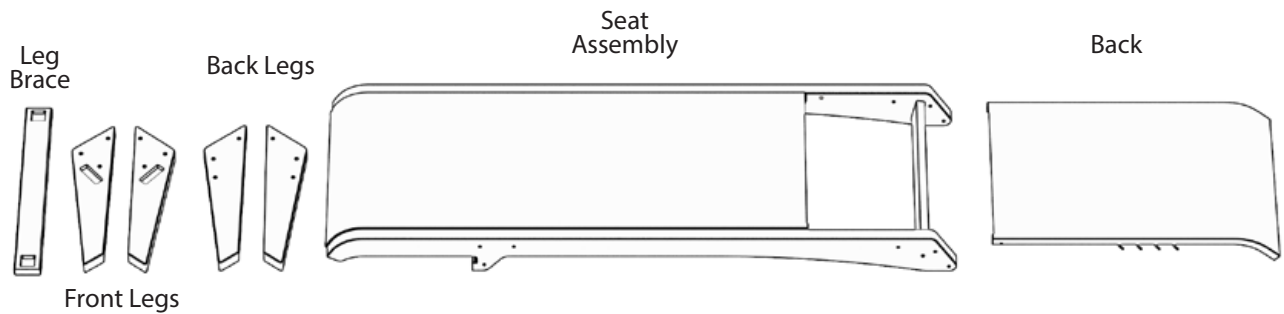

Step 1

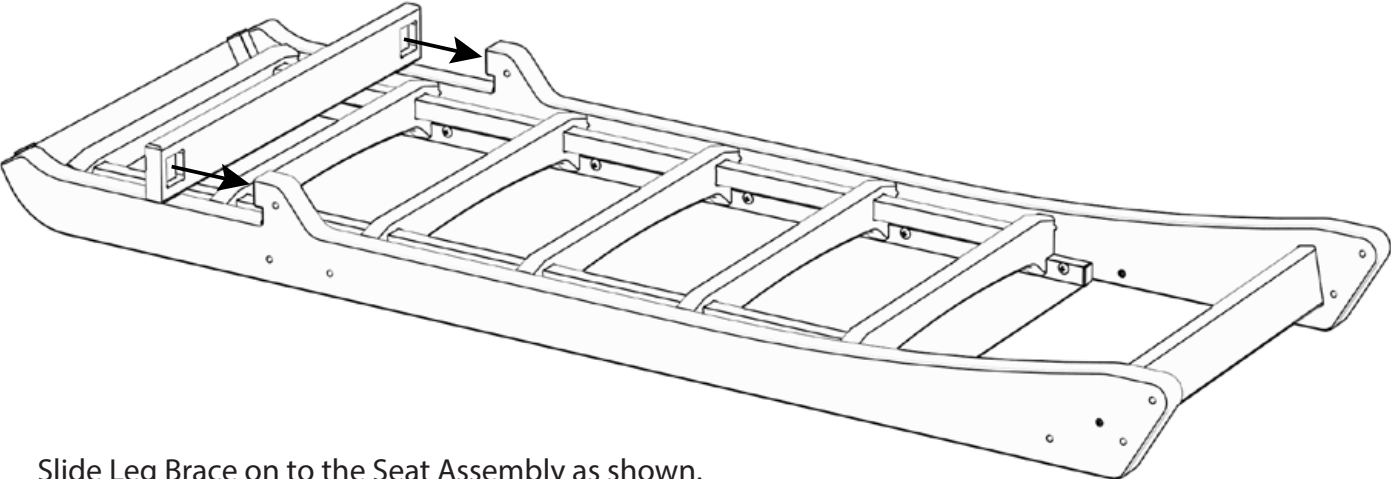

Slide Leg Brace on to the Seat Assembly as shown.

Step 2

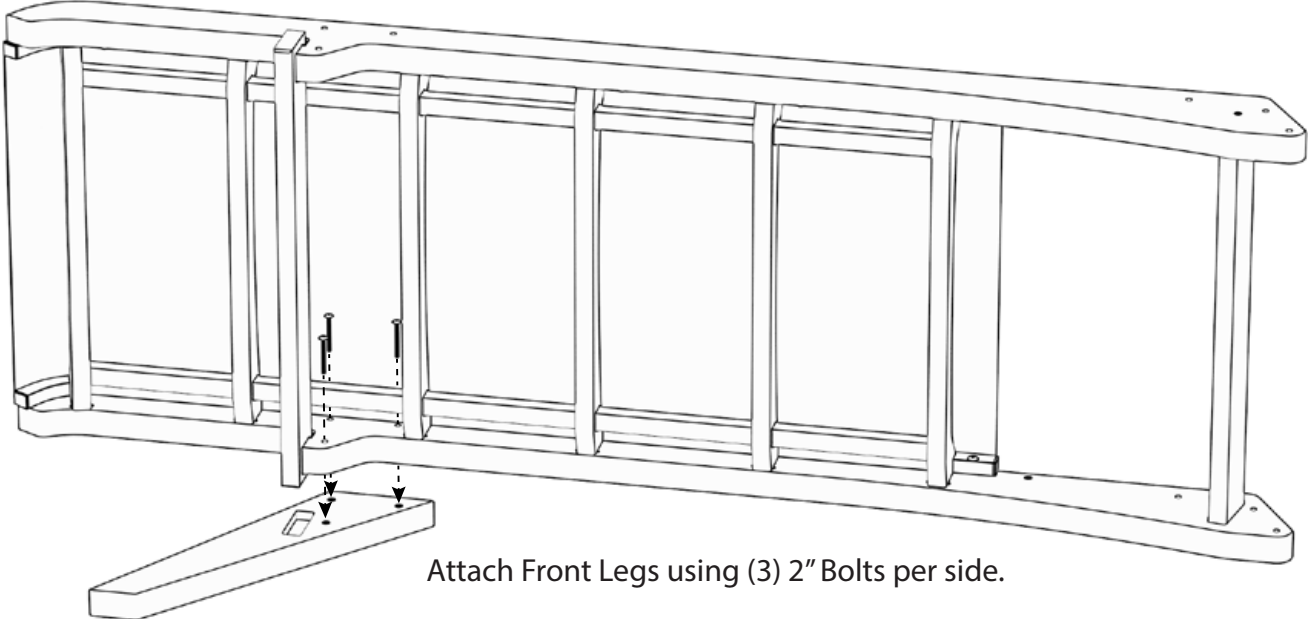

Attach Front Legs using (3) 2" Bolts per side.

Step 3

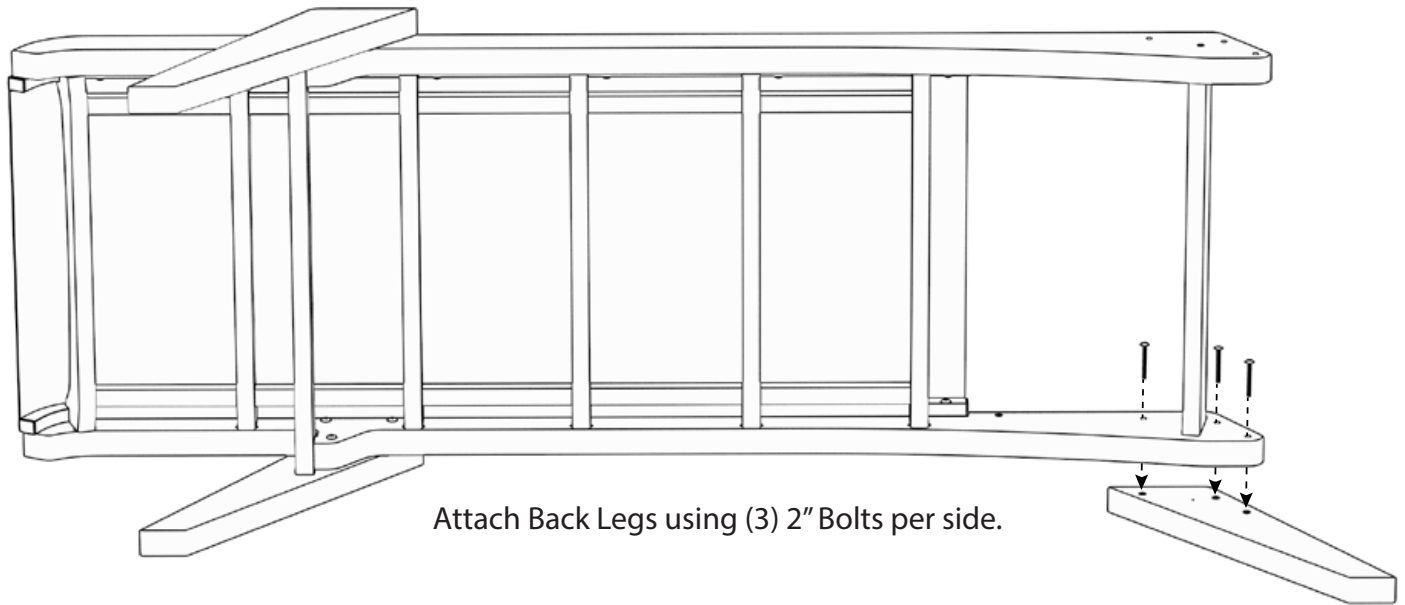

Step 4

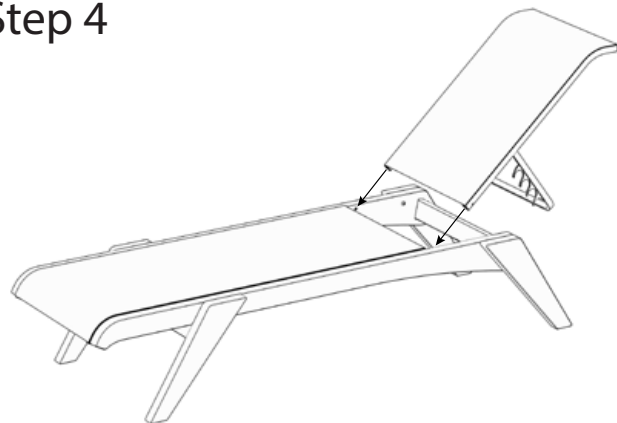

Position Back as shown above.

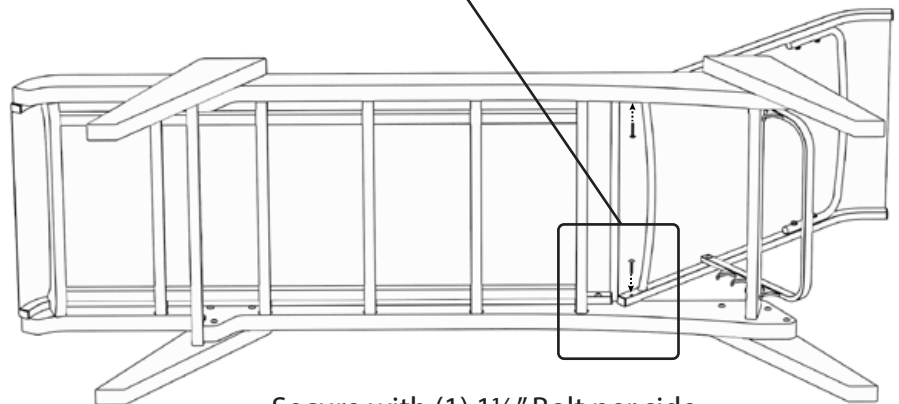
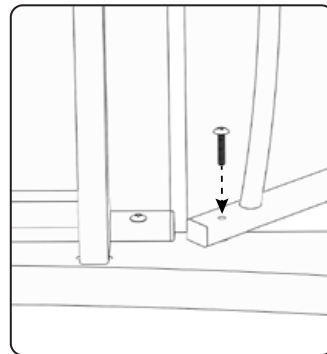

Secure with (1) 1 1/2" Bolt per side.