



PADDY O'

furniture

16" X 16" Side Table
CSADSY1616SN-CI





Tools Required

- *Drill
- *T20 torx (star) driver bit
- *Straight Edge

Assembly Tips

- *Perform assembly on a clean soft surface to prevent parts being scratched.
- *If your drill has a clutch set it to medium torque. Once parts are pulled together, add 1/4-1/2 turn.

Hardware Included

- | | | |
|--------------|---|------|
| 1 1/4" Screw |  | x 24 |
| 3" Screw |  | x 4 |

Parts Included

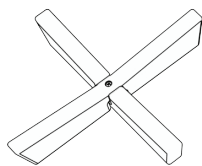

Leg Brace
Assembly

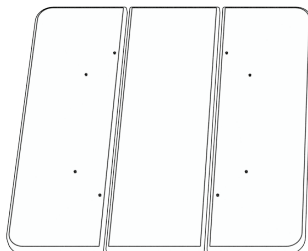

Top Boards

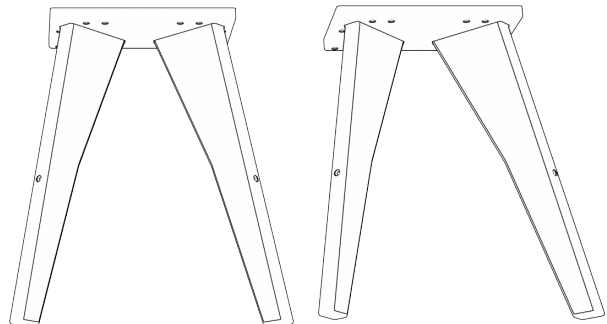

Leg
Assemblies

Step 1

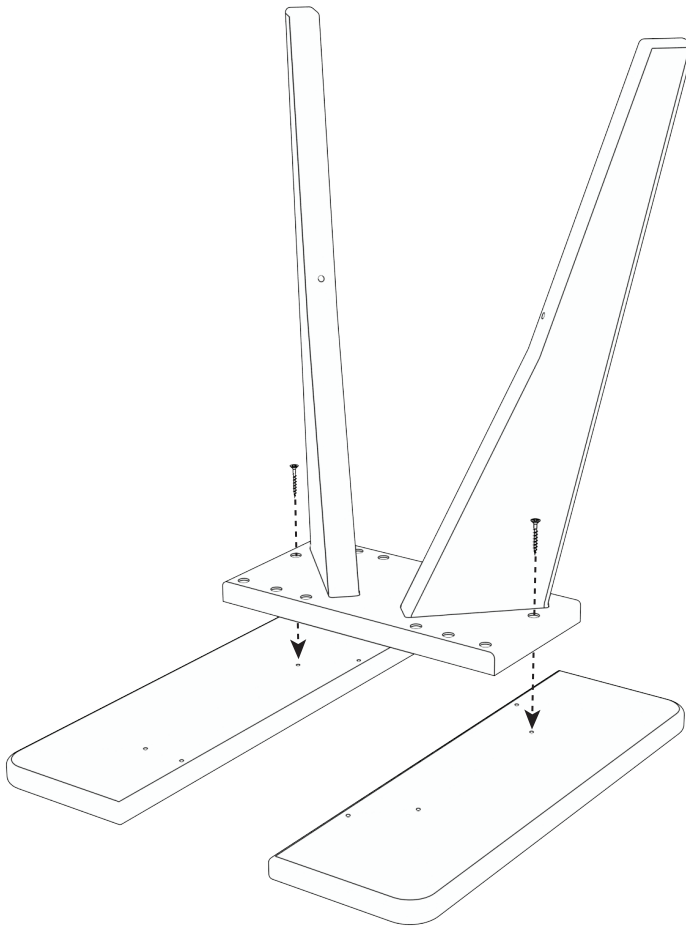

Align holes in Leg Assembly with divots on the outside Table Top Boards as shown. Secure with 1 1/4" Screws. Repeat with other Leg Assembly.

Step 2

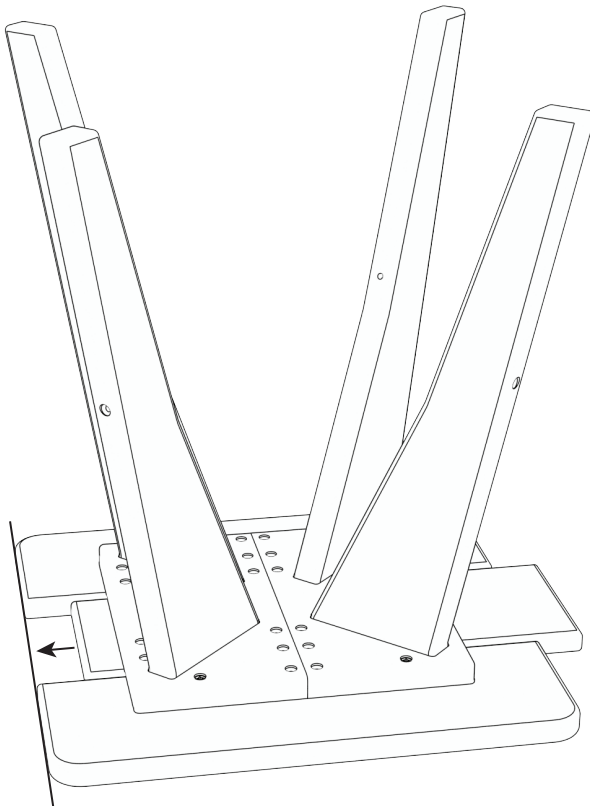

Ensure center top board has even spacing on either side. Secure with remaining 1 1/4" screws.

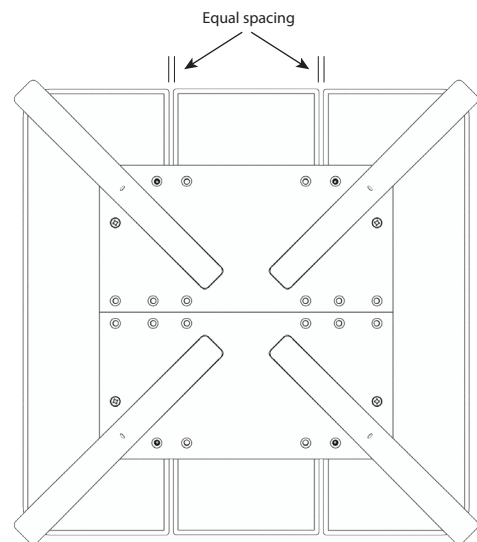

Using a straight edge align center top board to the edges of the outside top boards as shown.

Step 3

Lower Leg Brace Assembly into position.

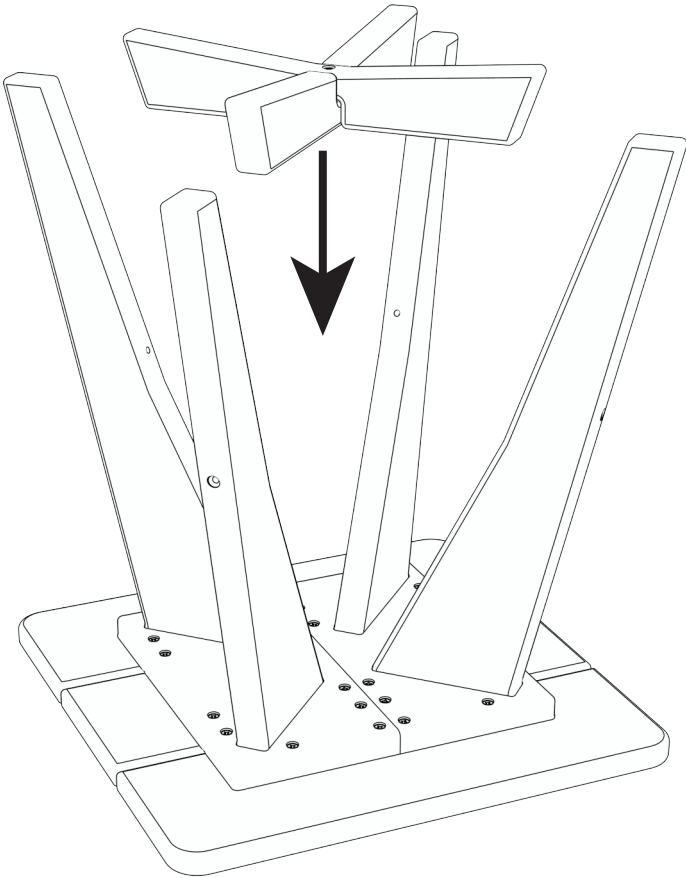

Step 4

Attach each Leg to Leg Brace Assembly using 3" screws.

