

Type FL

FM and VdS approved flange clamp for use with parallel or tapered flange beams, supplied with the rear hole drilled or tapped.

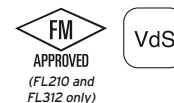
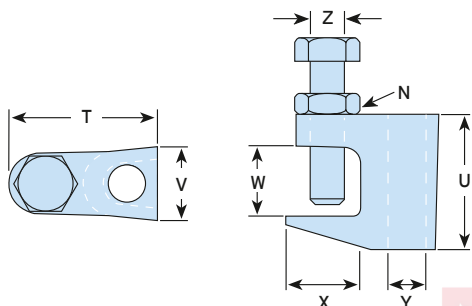
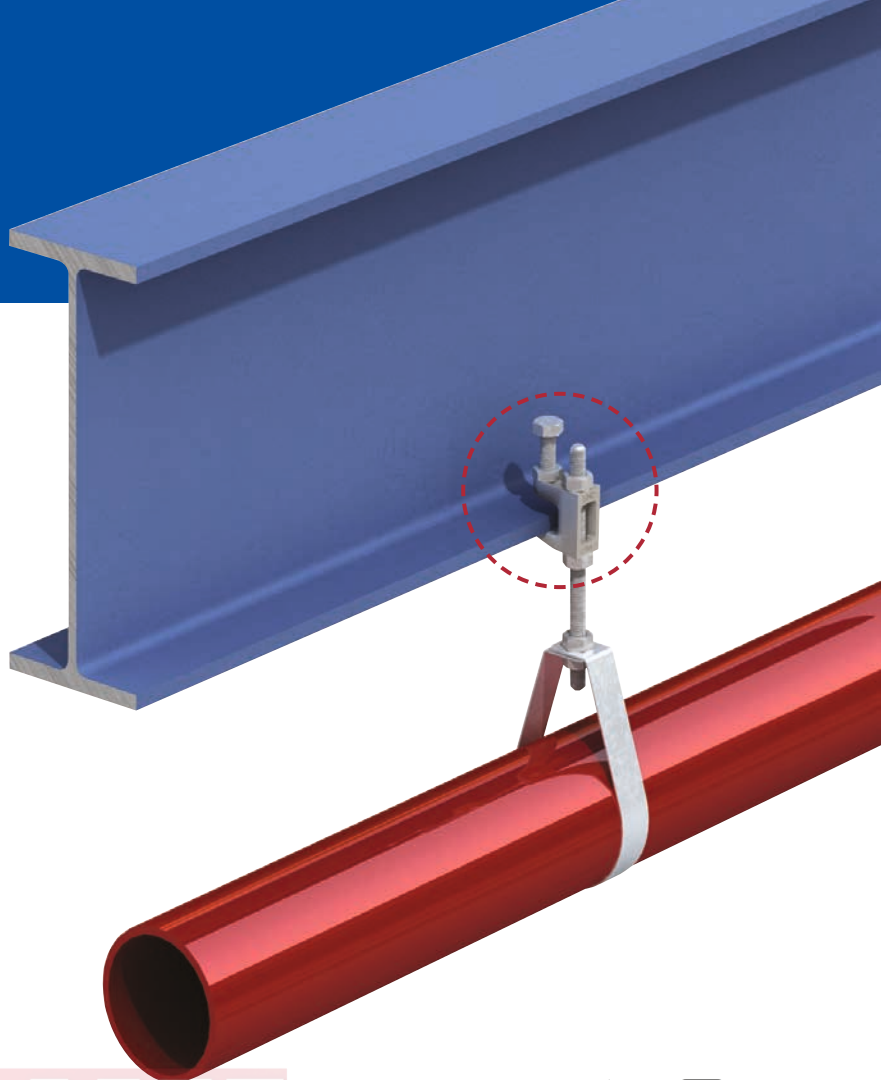
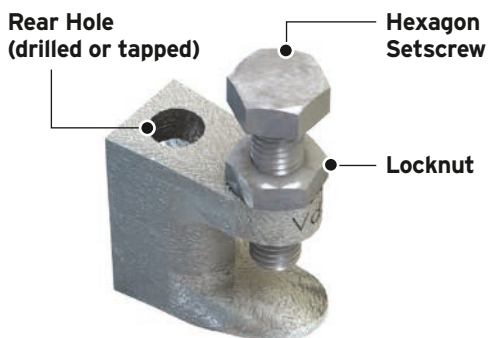

Material: Malleable iron, zinc plated.

Product Code		Clear Hole Ø Y mm	Tapped Thread Y	Safe Working Load (FOS 4:1) Tensile kN	Clamping Range W mm	Setscrew Z	Tightening Torque		Dimensions			
Clear	Tapped						Setscrew Z	Locknut N	T	U	X	Width V
FL106D	FL106T	7	M6	1.1	3 - 17	M8	8	11	36	35	20	19
FL108D	FL108T	9	M8	1.1	3 - 17	M8	8	11	36	35	20	19
FL210D	FL210T	11	M10	2.4	3 - 19	M10	8	22	45	40	22	22
FL312D	FL312T	13	M12	3.1	3 - 23	M10	8	22	50	46	28	25
FL412D	FL410T	13	M10	3.1	9 - 28	M10	8	22	53	51	27	26

➤ The Type FL can be used with Type SW (page 55) when connecting to inclined sections.

How to install...

- 1) Slide the Type FL onto the beam flange and tighten setscrew to the recommended torque. As a guide, tighten the setscrew finger tight and then apply an additional quarter turn (90°) with spanner.
- 2) Tighten the locknut (N) to the recommended torque.

➤ On tapered flanges, the cup point setscrew has to grip on the inside of the flange.

