

Design for
GALAXY TAB

COUNTERTOP / WALL / FLOOR SECURITY MOUNT

WITH KEYED LOCK, DRILL DOWN DESIGN & CABLE MANAGEMENT

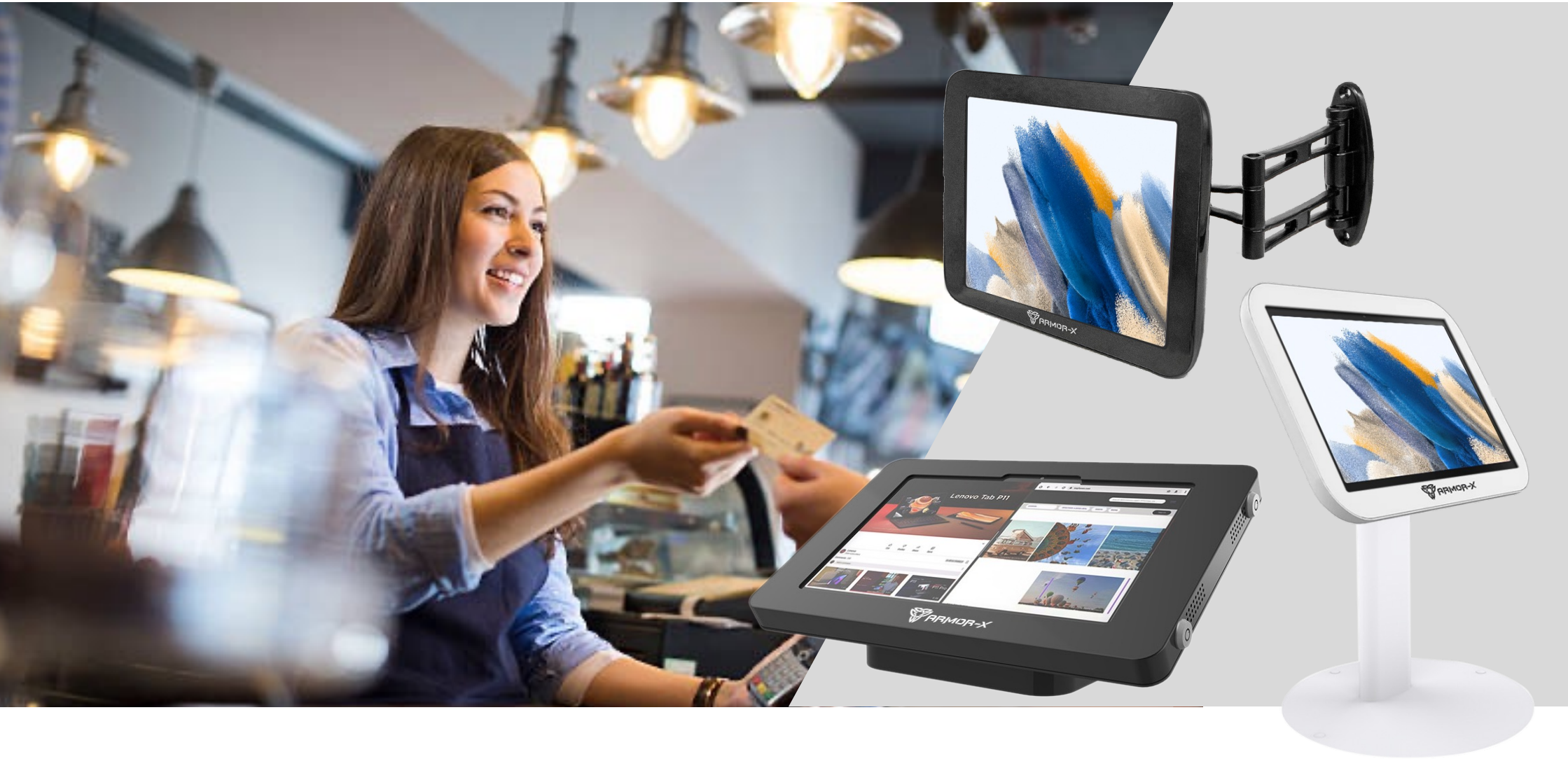

www.armor-x.com
© Copyright all rights reserved



SCM1-SS

2-IN-1 COUNTERTOP / WALL SECURITY MOUNT



- Designed for audio video conference rooms and telecommunication applications
- Quick lock and unlock keyed lock
- Conceals charging cable
- High-Grade Aluminum Enclosure
- fold, extend and Adjustable Long Arm
- 2-in-1 table stand & wall mount



**SECURED
DESIGN**

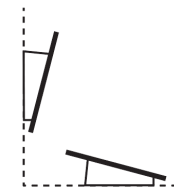

**WALL /
TABLE TOP**

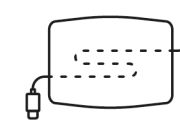

**CONCEALS
CABLE**

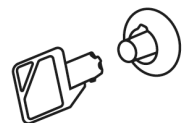

**KEY
LOCKS**

SCM2-SS

COUNTERTOP SECURITY MOUNT

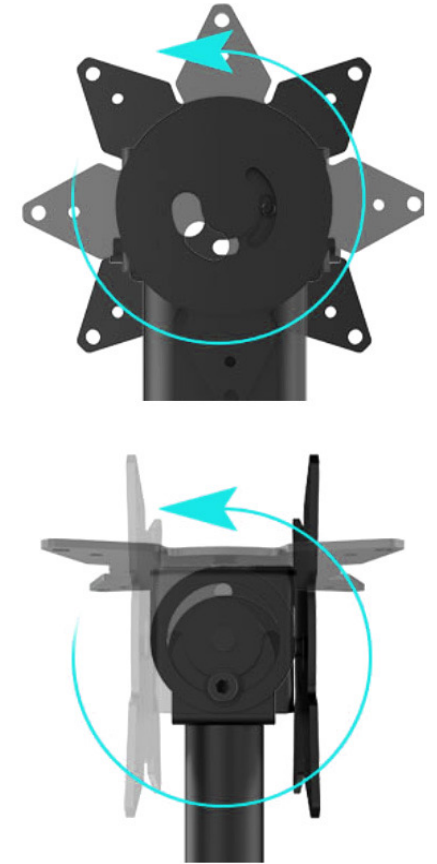

- Quick lock and unlock keyed lock
- Conceals charging cable
- Through arm cable management
- Compatible with our security cable lock



**SECURED
DESIGN**

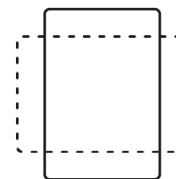

**LANDSCAPE / PORTRAIT
MODE**

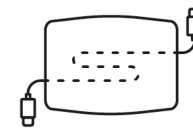

**CONCEALS
CABLE**

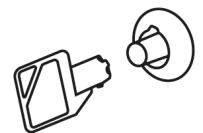

**KEY
LOCKS**

SCM3-SS

2-IN-1 COUNTERTOP / WALL SECURITY MOUNT



- High-grade aluminum enclosure
- Fold, extend and adjustable long arm
- 2-in-1 table stand & wall mount
- Wire and cable management
- Compatible with our security cable lock

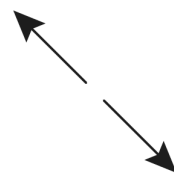

EXTENDS



SECURED
DESIGN

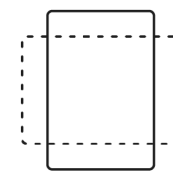

LANDSCAPE /
PORTRAIT MODE

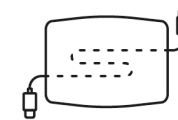

CONCEALS
CABLE

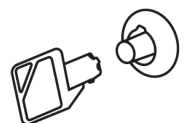

KEY
LOCKS

SCM4-SS

WALL SECURITY MOUNT



- Quick lock and unlock keyed lock
- Secured and easy to install
- Suitable for display and hand-held



**SECURED
DESIGN**

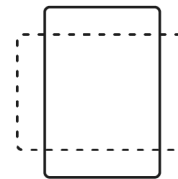

**LANDSCAPE / PORTRAIT
MODE**

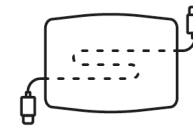

**CONCEALS
CABLE**

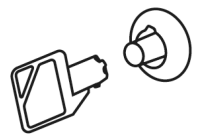

**KEY
LOCKS**

SCM5-SS

SECURITY CAR HEADREST MOUNT

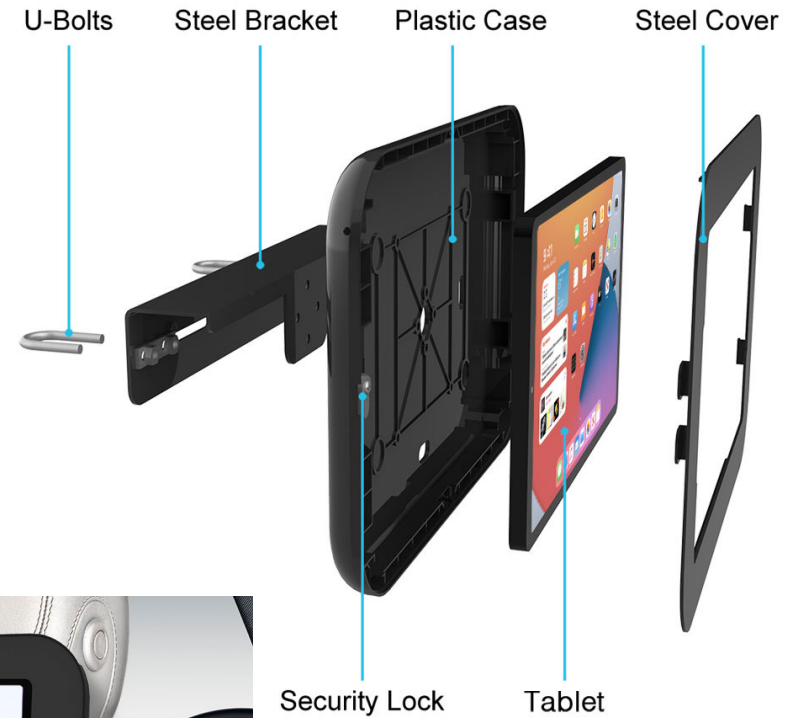

- Attaches to a variety of car headrest sizes
- High grade aluminum enclosure
- Conceals charging cable
- Quick lock and unlock keyed lock
- Compatible with our security cable lock



**SECURED
DESIGN**

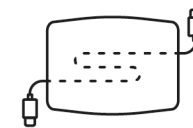

**CONCEALS
CABLE**

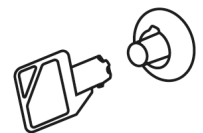

**KEY
LOCKS**

SCM6-SS

SWING SECURITY WALL MOUNT

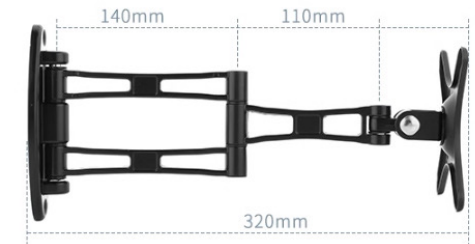
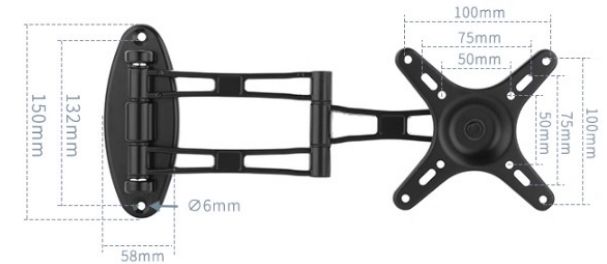
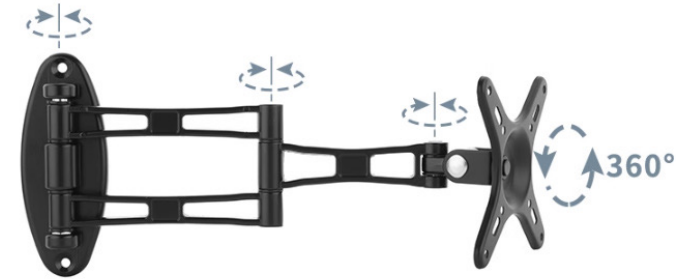

- Tamper-Proof Aluminum Enclosure
- Quick Lock and Unlock Keyed Lock
- Tilt, Pan, and Swing for Multiple Display Angles
- Compatible with our Security Cable Lock



SECURED DESIGN

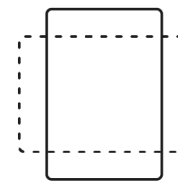

LANDSCAPE / PORTRAIT MODE

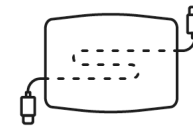

CONCEALS CABLE

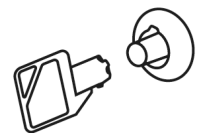

KEY LOCKS

SCM7-SS

EXTENDABLE FLOOR SECURITY MOUNT

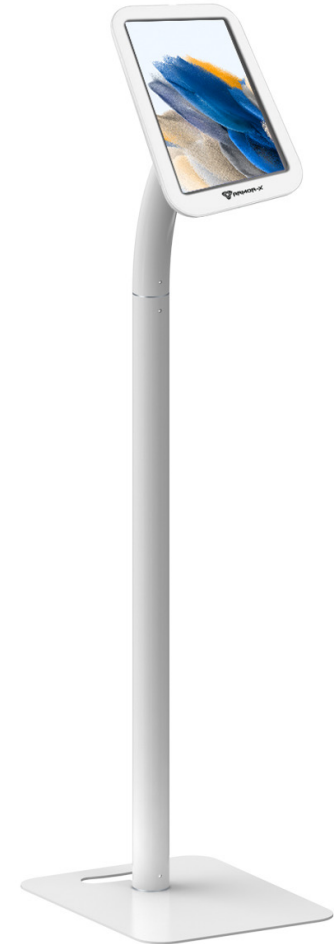
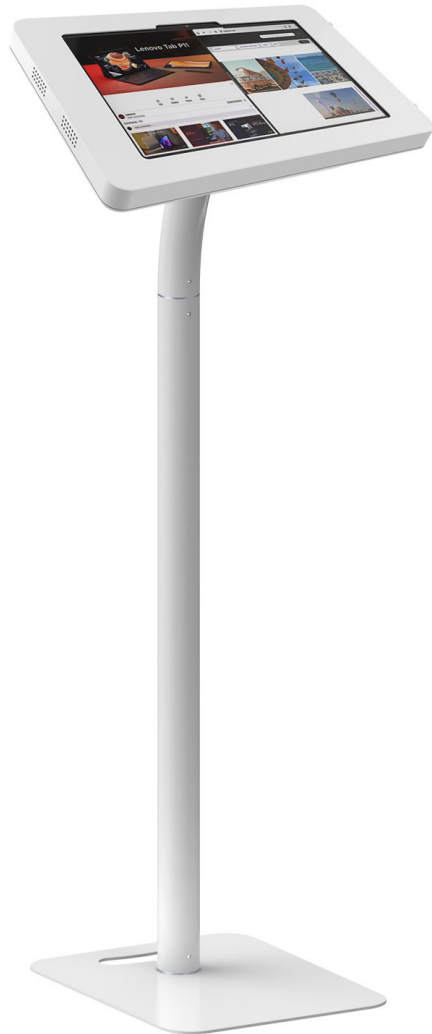

- Quick lock and unlock keyed lock
- Rotate between landscape or portrait mode
- Stand securely to any floor
- Leave freestanding and secure with an optional cable lock

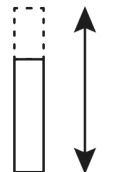

FLOOR /
TABLETOP



SECURED
DESIGN

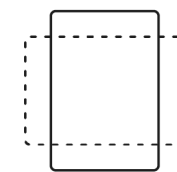

LANDSCAPE /
PORTRAIT MODE

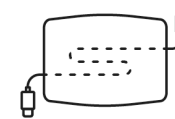

CONCEALS
CABLE

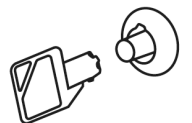

KEY
LOCKS

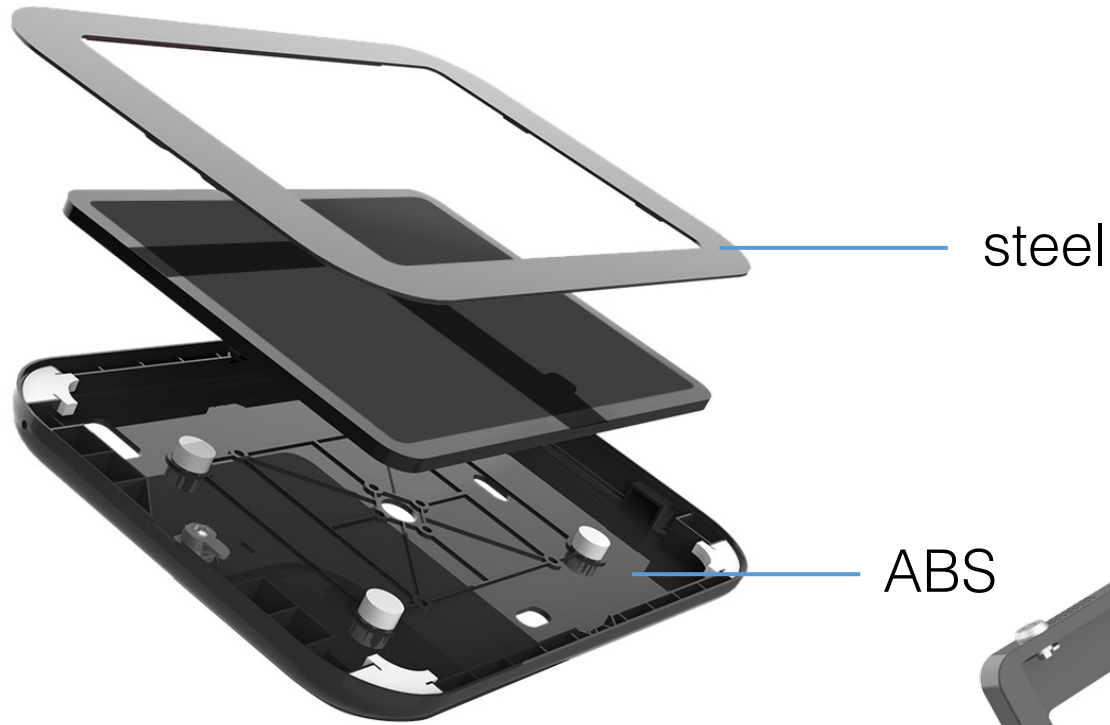

steel

ABS

Cover for screen size
between 9.7"-11"

Cover for screen size
between 11"-12.4"

aluminium



	MODEL	SKU	ENCLOSURE SIZE	PACKAGE SIZE	NET WEIGHT	GROSS WEIGHT	VOLUMETRIC WEIGHT
	Tab S9 / S9 FE / S8 / S7	SCM1-SS-S9	310*208*20 mm	350*250*140mm	1.3kg	1.6 kg	2.45 kg
	Tab A9+	SCM1-SS-A9PL					
	Tab A9	SCM1-SS-A9					
	Tab A8	SCM1-SS-A8					
	Tab A7	SCM1-SS-A7					
	Tab S9+ / S9FE+ / S8+ / S7+ /S7FE	SCM1-SS-S9PL	335*208*22mm	380*260*140 mm	1.4 kg	2.0 kg	2.77 kg
	Tab S9 / S9 FE / S8 / S7	SCM2-SS-S9	310*208*20 mm	350*250*120 mm	2.0 kg	2.3 kg	2.1 kg
	Tab A9+	SCM2-SS-A9PL					
	Tab A9	SCM2-SS-A9					
	Tab A8	SCM2-SS-A8					
	Tab A7	SCM2-SS-A7					
	Tab S9+ / S9FE+ / S8+ / S7+ /S7FE	SCM2-SS-S9PL	335*208*22mm	380*260*120 mm	2.1 kg	2.6kg	2.37 kg
	Tab S9 / S9 FE / S8 / S7	SCM3-SS-S9	310*208*20 mm	350*250*130mm	1.9 kg	2.2kg	2.28 kg
	Tab A9+	SCM3-SS-A9PL					
	Tab A9	SCM3-SS-A9					
	Tab A8	SCM3-SS-A8					
	Tab A7	SCM3-SS-A7					
	Tab S9+ / S9FE+ / S8+ / S7+ /S7FE	SCM3-SS-S9PL	335*208*22mm	380*260*130mm	2.0 kg	2.6kg	2.57 kg
	Tab S9 / S9 FE / S8 / S7	SCM4-SS-S9	310*208*20 mm	350*250*70mm	0.85 kg	1.1 kg	1.23 kg
	Tab A9+	SCM4-SS-A9PL					
	Tab A9	SCM4-SS-A9					
	Tab A8	SCM4-SS-A8					
	Tab A7	SCM4-SS-A7					
	Tab S9+ / S9FE+ / S8+ / S7+ /S7FE	SCM4-SS-S9PL	335*208*22mm	380*260*70mm	0.95 kg	1.4 kg	1.38 kg



**COLOR: BLACK / WHITE

www.armor-x.com
© Copyright all rights reserved





MODEL	SKU	ENCLOSURE SIZE	PACKAGE SIZE	NET WEIGHT	GROSS WEIGHT	VOLUMETRIC WEIGHT
Tab S9 / S9 FE / S8 / S7 Tab A9+	SCM5-SS-S9 SCM5-SS-A9PL	310*208*20 mm	350*250*70 mm	0.9 kg	1.2 kg	1.23 kg
Tab A9	SCM5-SS-A9					
Tab A8	SCM5-SS-A8					
Tab A7	SCM5-SS-A7					
Tab S9+ / S9FE+ / S8+ S7+ /S7FE	SCM5-SS-S9PL					
Tab S9 / S9 FE / S8 / S7 Tab A9+	SCM6-SS-S9 SCM6-SS-A9PL	310*208*20 mm	350*250*130mm	1.2 kg	1.5 kg	2.28 kg
Tab A9	SCM6-SS-A9					
Tab A8	SCM6-SS-A8					
Tab A7	SCM6-SS-A7					
Tab S9+ / S9FE+ / S8+ S7+ /S7FE	SCM6-SS-S9PL					
Tab S9 / S9 FE / S8 / S7 Tab A9+	SCM7-SS-S9 SCM7-SS-A9PL	310*208*20 mm	890*420*110mm	7.7kg	9.7kg	8.22kg
Tab A9	SCM7-SS-A9					
Tab A8	SCM7-SS-A8					
Tab A7	SCM7-SS-A7					
Tab S9+ / S9FE+ / S8+ S7+ /S7FE	SCM7-SS-S9PL					

**COLOR: BLACK / WHITE



OPTIONAL SAFETY KEY LOCK CABLE



LCK01
Security Key Lock



LCK02
Combination Security Lock

