



**SD-LA Installation Instructions
Solar-Direct Brushless
DC Lake Aerators**



Scott Aerator products are designed to be simple and easy to install. If, for whatever reason, you need help during installation, please give Scott Aerator's customer support a call. We are happy to help ensure each installation goes as smooth as possible. Have a comment or suggestion on how we can improve your experience? Let us know. We do appreciate your feedback.

Page

3	Installer Responsibility
3,4	Safety, Warnings & Cautions
5	SD-LA Basic System Overview
6,7	Site Planning and Preparations
8	Receiving Your Shipment
8	Installing the Solar Panel(s)
9	Installing the Aerator Post Mount
10,11	Connecting the Solar Panel(s) to the Aerator
11,12	Deploying the Diffusers
12	Commissioning the SD-LA
14	Warranty Registration
14	Making A Healthy Transition to An Aerated Lake or Pond
15	Troubleshooting



13245 Barry Street, Holland, MI 49424
616-392-8882 | 800-WATER-45 (800-928-3745) | Fax: 616-392-8860
information@scottaerator.com

Installer Responsibility

The installer is solely responsible for:

- Complying with all applicable local or national building codes, including any that may supersede this manual.
- Ensure that Scott Aerator and other products are appropriate for the particular installation and the installation environment.
- Ensure that the selected mount can support the array under live load conditions.
- Use only Scott Aerator parts and installer-supplied parts as specified by Scott Aerator. Substitution parts may void the warranty.
- **Ensure proper array/structure grounding**, including each module frame, the mounting pole and each rail. Failure to provide proper grounding may result in damage to your equipment or injury to personnel.
- **Do not rely on the mounting pipe to act as a ground rod!** It is not a reliable substitute for a properly installed grounding electrode system.
- If you are unfamiliar with NEC compliant solar electric installations, consult with the dealer that supplied your mount. They should have the skill and expertise to supply you with the necessary wiring diagrams and the appropriate connection wire, grounding equipment, junction boxes and fusing.

Safety, Warnings & Cautions



Safety warnings are not in this manual for our benefit; **they are for you.** Please follow them carefully.

You must read, understand, and comply with all of these safety instructions in order to protect your life and safety, and to prevent equipment problems or damage. Failure to follow the instructions in this chapter may void equipment warranties.



We make every effort to remove sharp edges from our products. However, we highly recommend wearing gloves when handling metal parts in order to avoid sharp edges.

Before you begin any digging for the post, you MUST make absolutely sure that there are no buried lines in the area that you'll be working. Buried utility lines can be LETHAL if struck and / or damaged.

Use your head and PLEASE do not become a statistic!



Note:

Locating services are normally provided for FREE by the utility company or one of their contractors. The Utility Company will not normally locate privately-owned lines, such as propane lines or wiring buried between buildings on your property.



CAUTION!

Check for any Overhead Power Lines that may be in or near your work area. Contact with power lines will ruin your day and very likely kill you.

You won't be able to tell everyone how cool your new Solar Lake Aerator is if you've been reduced to a smoldering heap on the ground.



Be Aware of Thin Ice Hazards!

Ponds and lakes with aeration systems in use throughout the winter months can be very dangerous. Many States or localities may require that these lakes be clearly marked with signs declaring them hazardous due to thin ice or open water during the winter. **DO NOT** attempt to walk on aerated lakes, and ensure all proper precautions are taken to prevent severe harm or death to yourself or others!

SD-LA Basic System Overview

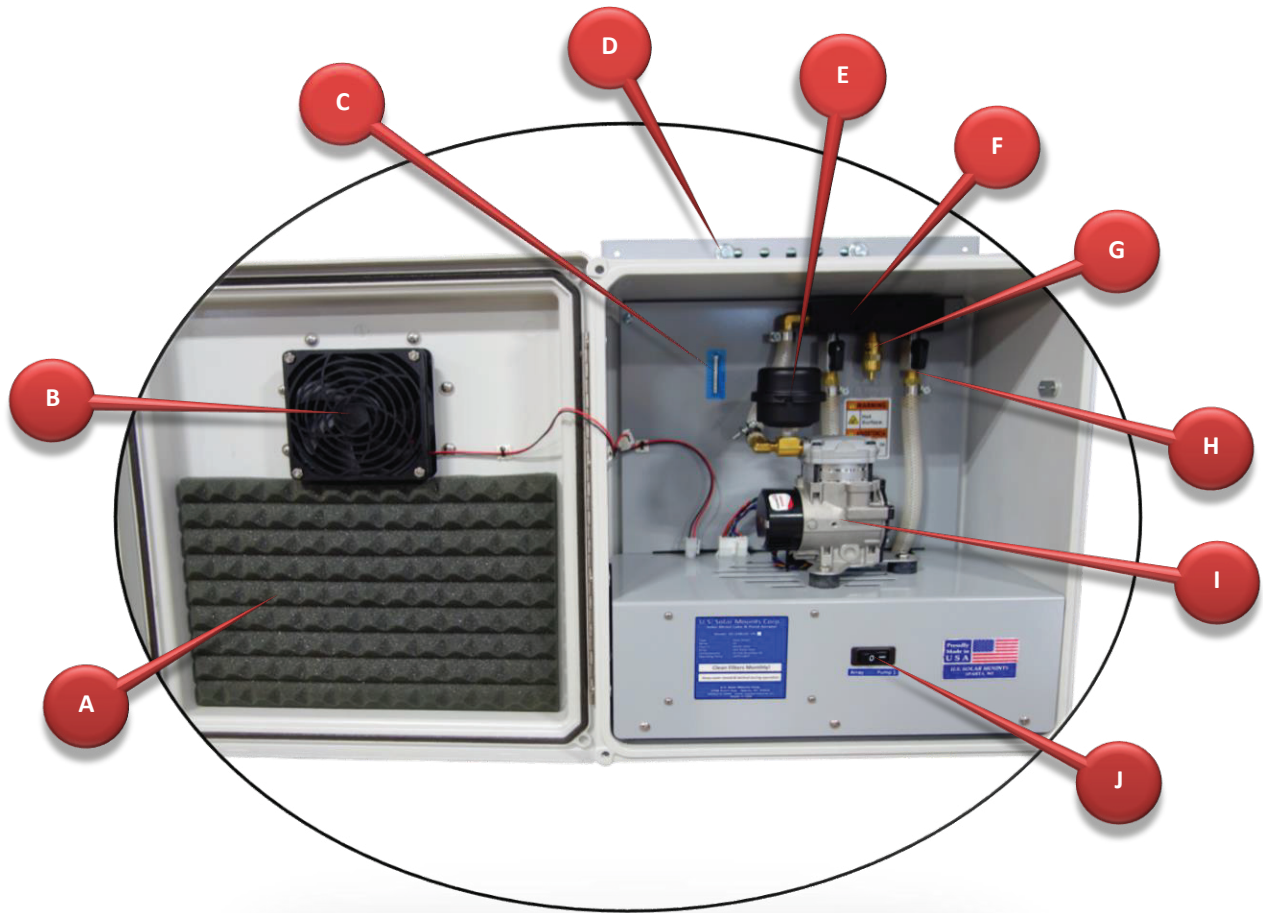

(SD2-PM Shown)

Basic System Components	
A	Sound Dampening Foam
B	Enclosure Cooling Fan
C	Temperature Recording Strip (Warranty Void if Removed)
D	Pole Mounting Plate
E	Compressor Intake Filter (Must Be Kept Clean)
F	Manifold Assembly
G	Pressure Relief Valve
H	Diffuser Hose Entries and Flow-Balancing Valves (Shown Open)
I	Compressor
J	Circuit Breaker / Compressor Power Switch

SD-LA Basic System Overview

Note: This section can be completed before or after receiving your SD-LA system(s).

When choosing an installation location for the SD-LA aerator, keep the following in mind:

Your solar array needs clear, unrestricted access to direct sunlight during the day.

Try to keep your hose runs similar in length.

Locate the compressor enclosure in a place that is safe from flooding/high water.

Ensure clear air space around the enclosure for proper ventilation.

Keep clear of pathways & driveways – (vehicles, tractors, lawnmowers, ATVs, etc).

IMPORTANT!



Checks Vents & Fan Regularly!



The enclosure **MUST HAVE** unobstructed airflow around the cooling intake & exhaust vents. Keeping these vents clear and open is critical to keeping the compressor cool. It is very important that you check the vents regularly to ensure that they are not obstructed/clogged.

Failures due to restricted airflow are not covered under Warranty!

 **IMPORTANT!**

DO NOT place the enclosure within another enclosure (like fake rocks).

DO NOT paint, coat, insulate, or modify the enclosure and/or cooling system.

Doing so could give you diaper rash and WILL void your Warranty!

 **IMPORTANT!**

Your warranty requires that proper ventilation be maintained at all times.

Failures resulting from Overheating are not covered by the product warranty.

Site Planning: Solar Access

The air output of your SD-LA relies on having as much direct sunlight as possible at any given time. Even a small amount of shade cast onto a fraction of your solar array can affect the production of your system. Use the following diagrams to help find the right location for your installation.

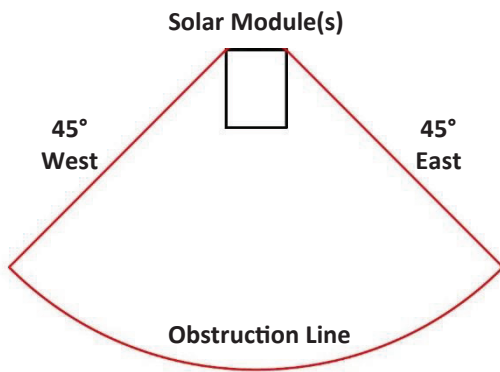
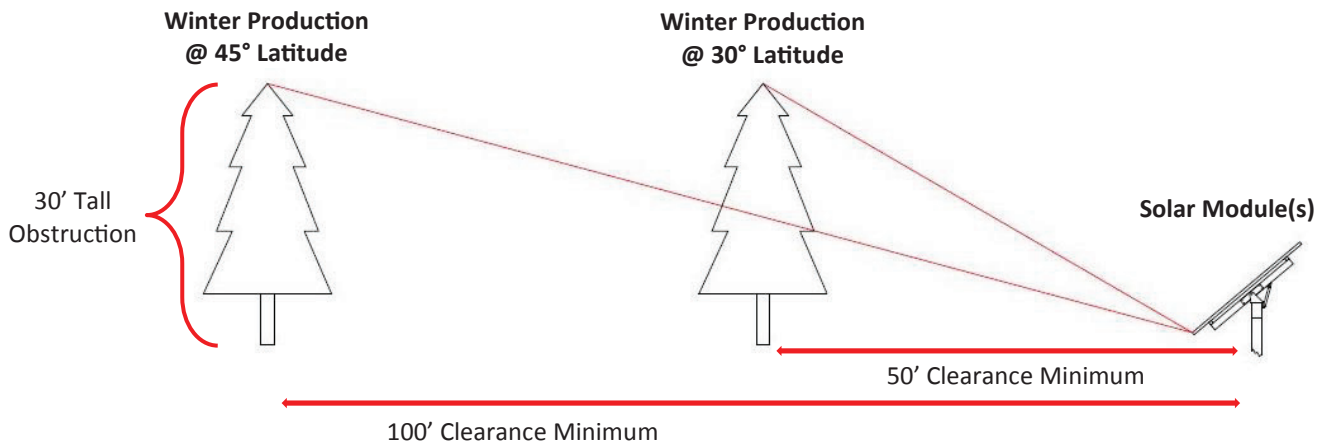

NOTE: Any shading on the panels during the day can dramatically affect the air output of the SD-LA. Ensure you have picked a good location for the panels.

Once you have chosen a suitable location for your installation, you can begin preparing for your SD-LA. Each individual SD-LA unit will require its own installer-supplied steel mounting pole. The foundation and pole can be installed before or after receiving your aerator.

Please refer to the supplied Solar Mount Installation Instructions for foundation details.

Receiving Your Shipment

The site chosen for the installation and/or delivery of the SD-LA System may need to have adequate access for delivery trucks, semi-tractors, or any other equipment necessary to offload the skid(s) upon arrival. Scott Aerator may request assistance with shipping and logistics.

Upon delivery of the Aerator system, the customer is responsible for inspecting the shipment for any damages incurred during shipping. If any damage is apparent, a claim must be made with the driver upon drop-off.

The SD-LA normally arrives packaged on a single skid with all components present. You may wish to use some form of equipment such as an all-terrain forklift or track loader for unloading the shipment and relocating the materials on the jobsite. The skid will be fairly heavy, but each individual piece can be handled by no more than two people.

Please note: Multiple-unit orders will likely come packaged on multiple skids, optimized to make the best use of materials and to keep freight costs to a minimum.

Installing the Solar Panel(s)

Refer again to the supplied Solar Mount Installation Instructions for assembly of the Solar Mount and installation of the Solar Module(s).

Once the mount has been assembled, use the following table to assist in setting a proper tilt angle for optimal year-round production.

Recommended SD-LA Array Tilt (Optimal Year-Round*)	
<u>Latitude</u>	<u>Tilt Angle</u>
0° to 25°	20°
25° to 35°	30°
35° to 45°	40°
45°+	50°

*Angles shown are based on optimal year-round tilt angles for a fixed array and may not be accurate for all locations. Arrays can also be adjusted seasonally for better production. Consult with your dealer or a local solar professional for more information on what angle will work best for your area.

Installing the Aerator Post Mount

The Pole-Mounting Plate has holes included for clamping to a 3" or 4" steel pole. Standard packaging includes 2 Clamping U-Bolts for a 3" steel pole. For other mounting methods, hardware will need to be sourced by the customer or installer.

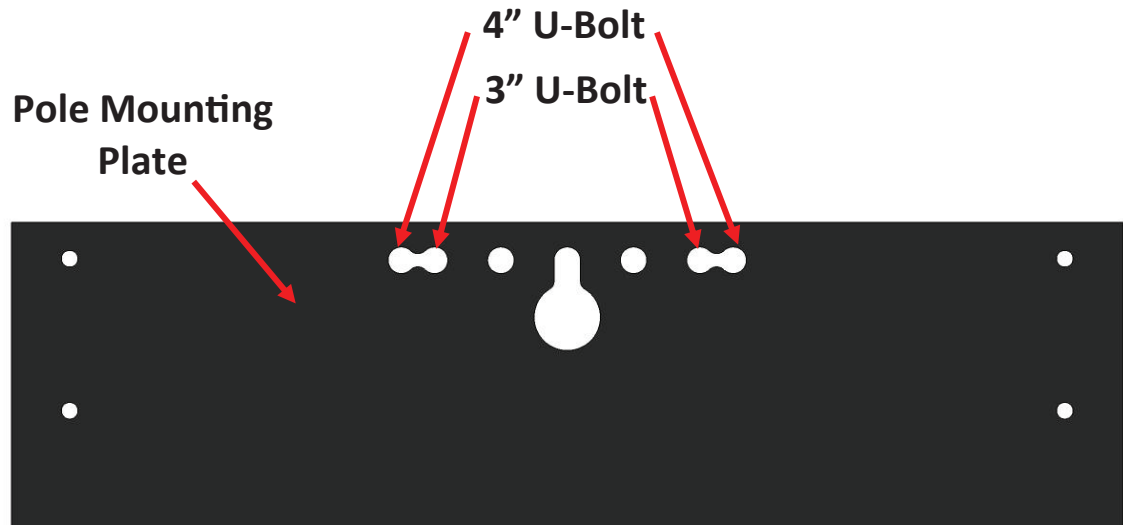

NOTE: 2 people are recommended for this step as the aerator enclosure is heavy.

Attach the Aerator to the pole as shown below, with the box on the North side of the pole to allow clearance for the solar modules and mount. Leave the hex nuts loose while positioning the Aerator. Ensure there is enough clearance at the bottom of the box to keep the Air Intake out of any potential grass/weed growth in the future. Tighten the hex nuts evenly once you are happy with the positioning of the Aerator.

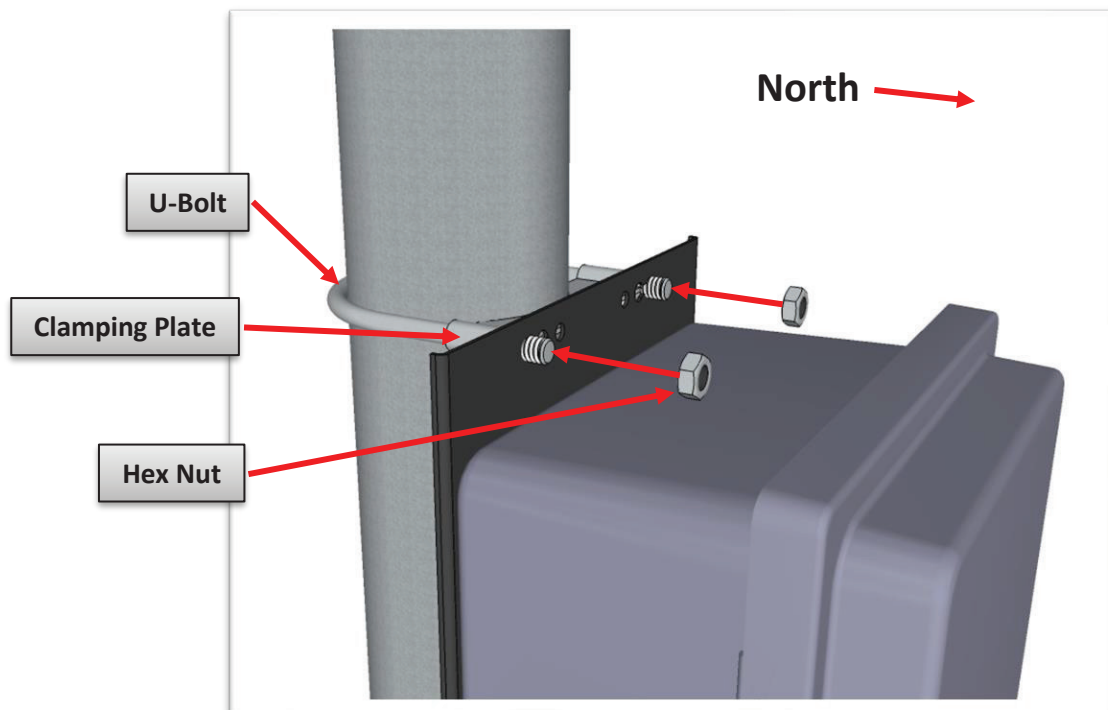

Connecting the Solar Panel(s) to the Aerator

Use the following diagram for connecting the panel(s) to the SD-LA.

DO NOT connect the positive and negative leads of the same module together!

DO NOT connect multiple modules in Series, as shown in the bottom diagram!

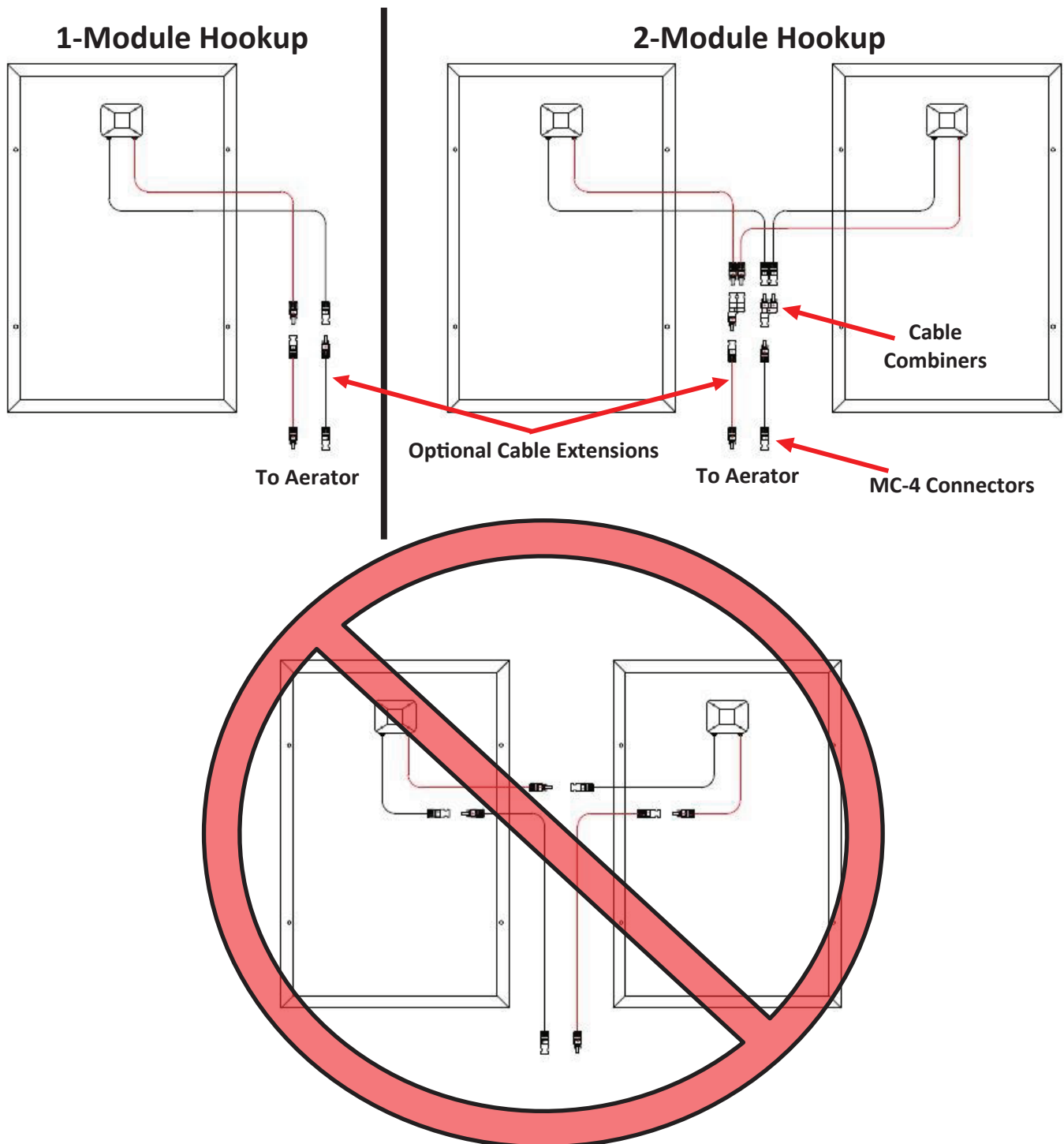

Once the proper connections have been made at the array, route the remaining positive and negative leads to the SD-LA enclosure. Take care to route the cables so that they are neat and protected from physical damage.

While the PV output leads supplied with the unit may be direct-buried, the MC-4 Solar connectors should **NEVER BE BURIED**. These leads may also be installed in a suitably-sized PVC conduit. In areas where damage by animals or livestock is of concern, the installer is responsible for restricting access to the enclosure, wiring, and array.

If you have any questions about wiring methods and/or procedures, please call Scott Aerator at 800-928-3745. We'll be glad to offer advice & guidance.

Deploying the Diffusers

Deploying the aeration diffusers will most likely be easiest with the assistance of a boat appropriate for the body of water you will be aerating. A second person may also be helpful for this step to ensure the weighted hose deploys properly.

The weighted hose may need to be trimmed or extended, depending on the positioning of the diffusers relative to the enclosure. If the diffusers and hose were not sourced from US Solar Mounts, the installer is responsible for supplying the necessary hose, diffusers, and fittings. The SD-LA comes with 3/8" brass barb fittings for the external hose connections.

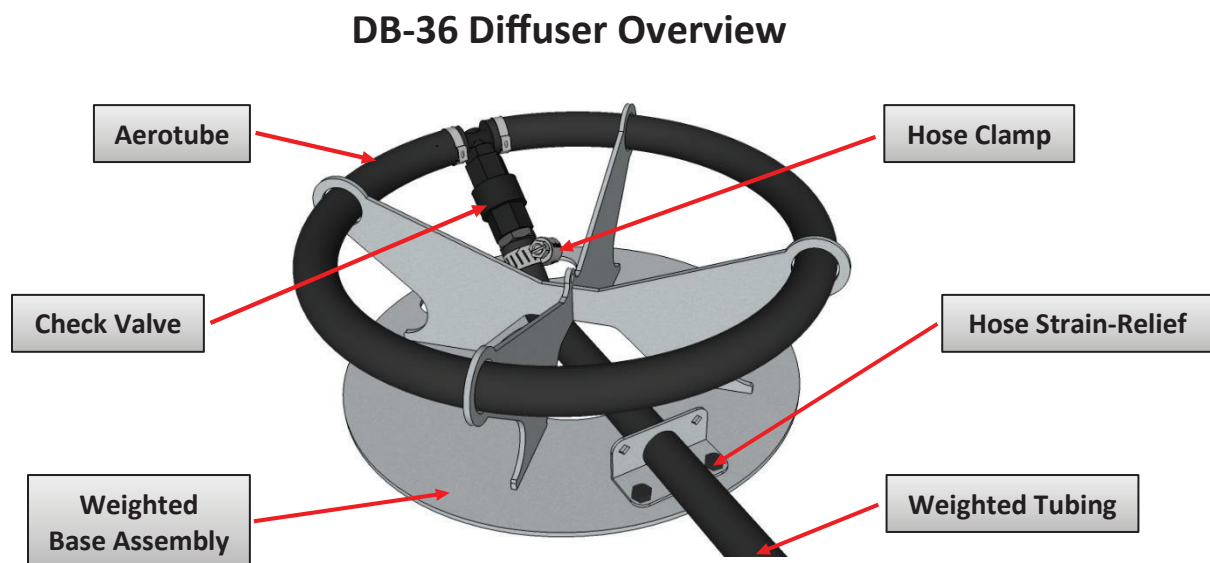

Once assembly is complete as shown, uncoil the remaining weighted hose on shore and begin pulling the diffuser to the desired location. The diffuser can either be dropped to the lake bottom or be tied to a line so it can be lowered into position.

Note: Do not forget to tie a float to the diffuser if you plan on removing them for any reason! A float will also assist in regularly checking and cleaning the diffuser to ensure proper function.

WARNING!!

Use proper boating and water safety precautions while deploying the aerator diffusers!

Note: The positioning of the diffusers can have a large impact on the overall effectiveness of the aeration process and also in maintaining the general health of your pond or lake. Consult your DEALER or Professional Aquatic Engineer to help determine the most effective way to operate your SD-LA and to optimize diffuser locations.

After the diffusers have been lowered into place, trim the weighted hose to the finished length and then attach them to the SD-LA as shown.

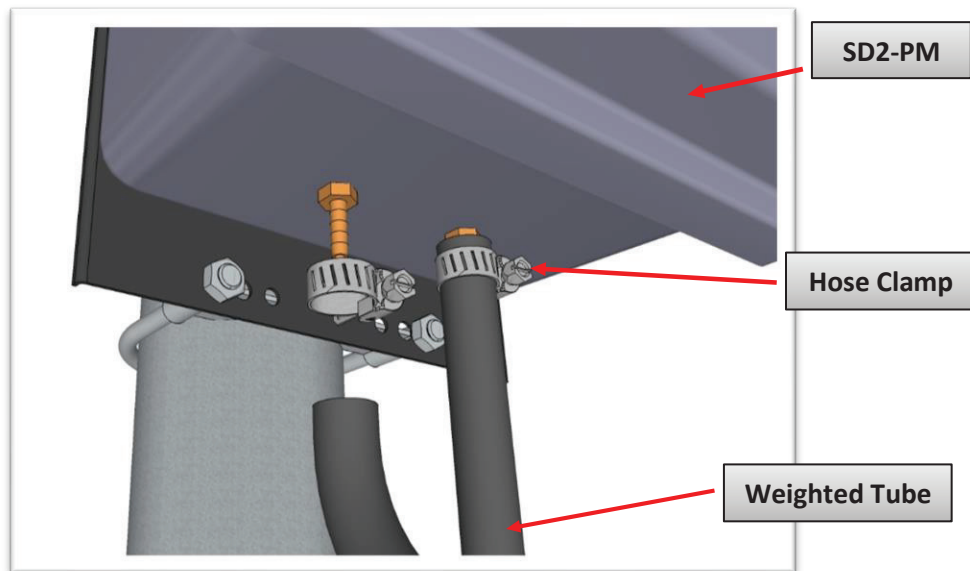

Commissioning the SD-LA

Note: The performance of the SD-LA during commissioning is solely dependent on the solar conditions at that time. Scott Aerator recommends waiting for good solar conditions before completing the initial start-up of the aerator to ensure proper system performance.

With the SD-LA connected to the solar modules and the diffusers deployed, the system can now be turned on. Ensure the ball valves are open fully on the manifold(s) by turning the knobs so they are in line with the valves.

DO NOT start or operate the system with all balancing valves closed!
This may damage the system and void the Warranty.

Turn the system on by toggling all of the breakers to the on position. Ensure the cooling fan and compressor(s) appear to be running properly. Then, adjust the balancing valves as necessary to even out the flow to each diffuser. This is best done by watching the bubbles rise from each head and adjusting the valves until both streams are approximately equal.

Once all adjustments have been completed and the system appears to be running properly, close the lid and secure both of the latches. The SD-LA installation is now complete!



SD2-PM Package Shown
(pole not included)

The Scott Aerator Company Product Warranty

All standard Scott Aerator Company products are warranted to the original owner for five years against motor defects in materials or workmanship, no questions asked. All other product components are warranted for one year from date of purchase. Scott Aerator Company will replace failed parts under warranty when the defective unit is returned to the factory, shipping prepaid by customer, if factory inspection establishes that the part was defective. The unit must be returned to the factory prior to shipment of replacement parts. All parts replaced under this warranty if requested will be returned with shipping prepaid. Scott Aerator Company will not be liable for consequential damage nor for any costs associated with removal or attempts to repair components in the field.

Making A Healthy Transition to An Aerated Lake or Pond

When installing an aeration system in an older, existing pond, a few extra steps are recommended for ensuring a healthy transition to a fully aerated body of water.

An old pond will most likely have a thick layer of unhealthy muck built up at its bottom that may contain damaging amounts of harmful gasses. Disturbing this layer could cause foul odors to rise to the surface upon activation of an aeration system. In sufficient concentration, this could also harm or kill fish or other aquatic life if allowed to mix into the pond too rapidly.

To avoid any such issues, it is recommended that the aerator(s) be operated intermittently at first. Operate the system for only 30 minutes to an hour for the first couple days. Increase the run time by at most one hour each day, until reaching the final desired operational period. This should allow enough time for the harmful gasses to escape. It will also give your pond and fish some time to get used to the changes in the water ecosystem, preventing any harm.

Troubleshooting

In the unlikely event that your SD-LA experiences an issue, use the troubleshooting chart below to assist with determining the problem and a solution.

Troubleshooting Guide		
Issue	Possible Cause	Solution
Compressor won't run at all	Poor solar conditions/very dark clouds	Wait for better conditions
	Shading on modules	Correct or remove cause of shading.
	Snow on Modules	Remove snow from the array.
	Damaged or Failed electrical connection	Check all connections & repair or replace
	Tripped circuit breaker	Reset breaker. If problem persists, the compressor likely needs replacement.
	Compressor has failed	Replace compressor
	Controller has failed (extremely rare)	Replace controller
Compressor runs intermittently	Poor solar conditions/clouds	Wait for better conditions. Unit will Auto Re-start
	Enclosure over-temperature	See "Enclosure Over-Heating" below.
	Compressor Over-Current	The controller will shut down the compressor if an over-current condition occurs. This could be a sign that the compressor needs replacement.
Pressure Relief Valve is "popping off"	Hose is kinked, crushed or damaged	Repair or replace damaged hose
	Diffuser(s) are clogged	Clean diffusers
	Diffuser(s) too deep in lake	Relocate diffusers
	Possible ice in hose(s)	<u>DO NOT</u> operate the system in this condition. Shut down the system and Remove ice from the lines.
	Balancing valves are too restricted	Adjust valves
Compressor runs - low air output	Poor solar conditions/clouds	Wait for better conditions
	Balancing valves set incorrectly	Adjust valves
	Compressor Intake Filter is dirty	Replace the filter
	Hose(s) kinked, crushed or damaged	Repair or replace the hose
Enclosure Over-Heating	Dirty Enclosure Intake Filter(s)	Clean or replace filters
	Obstructed intake and/or exhaust ports	Remove obstruction(s)
	Cooling fan(s) stopped	Check the circuit breaker for the fan(s). If the breaker is not tripped, this indicates that the cooling fan(s) has failed and needs replacement.
<p>If you have any questions about your SD-LA System or need replacement parts, please contact Scott Aerator. We'll be glad to assist you in getting your system up and running as quickly as possible.</p>		