



**TOP OF POLE MOUNTS  
30 SERIES INSTALLATION  
Models 3160, 3260**

Scott Aerator products are designed to be simple and easy to install. If, for whatever reason, you need help during installation, please give Scott Aerator's customer support a call. We are happy to help ensure each installation goes as smooth as possible. Have a comment or suggestion on how we can improve your experience? Let us know. We do appreciate your feedback.

Page	
<b>3</b>	<b>Installer Responsibility</b>
<b>4</b>	<b>Tools that You'll Need</b>
<b>5</b>	<b>Safety, Warnings &amp; Cautions</b>
<b>6</b>	<b>Main Components &amp; Overview</b>
<b>7</b>	<b>Locating the Array</b>
<b>9</b>	<b>Pole &amp; Foundation Installation</b>
<b>10</b>	<b>Foundation Diagram</b>
<b>11</b>	<b>Array Assembly</b>
<b>12</b>	<b>Strong-Back &amp; Angle Brace</b>
<b>13</b>	<b>3160 – Installing the Mounting Ribs</b>
<b>14</b>	<b>3160 – Installing the Panel</b>
<b>15</b>	<b>3260 – Installing the Panel Rails</b>
<b>16</b>	<b>3260 – Installing the Panels</b>
<b>17</b>	<b>Setting Array Elevation</b>
<b>19</b>	<b>Array Grounding</b>



13245 Barry Street, Holland, MI 49424  
616-392-8882 | 800-WATER-45 (800-928-3745) | Fax: 616-392-8860  
information@scottaerator.com

## Installer Responsibility

The installer is solely responsible for:

- Complying with all applicable local or national building codes, including any that may supersede this manual.
- Ensure that Scott Aerator and other products are appropriate for the particular installation and the installation environment.
- Ensure that the selected mount can support the array under live load conditions.
- Use only Scott Aerator parts and installer-supplied parts as specified by Scott Aerator. Substitution parts may void the warranty.
- Ensure proper array/structure grounding, including each module frame, the mounting pole and each rail. Failure to provide proper grounding may result in damage to your equipment or injury to personnel.
- Do not rely on the mounting pipe to act as a ground rod! It is not a reliable substitute for a properly installed grounding electrode system.
- If you are unfamiliar with NEC compliant solar electric installations, consult with the dealer that supplied your mount. They should have the skill and expertise to supply you with the necessary wiring diagrams and the appropriate connection wire, grounding equipment, junction boxes and fusing.

## Tools That You'll Need

You'll need a few basic hand tools in order to perform the installation of your array:

1. 2' level(s)
2. Tape Measure
3. 1/2" Wrench
4. 9/16" Wrench
5. 3/4" Wrenches
6. Pencil or Sharpie
7. Wheelbarrow or Tub
8. Garden Hoe
9. Post Hole Digger
10. Shovel
11. Work Gloves
12. Compass or Smartphone App

In addition, the following materials will need to be acquired:

1. **FOR 30 SERIES: 3" SCH40 Mounting Pipe (3-1/2" Outside Diameter)**
2. Concrete
3. 2x4s or other bracing material
4. 8'x5/8" Copper-Clad Ground Rod, Wire & appropriate clamps



**NOTE: The Mounting Pipe MUST BE made of Steel.**  
**DO NOT use a PVC Pipe for mounting the Array.**

## Safety, Warnings & Cautions

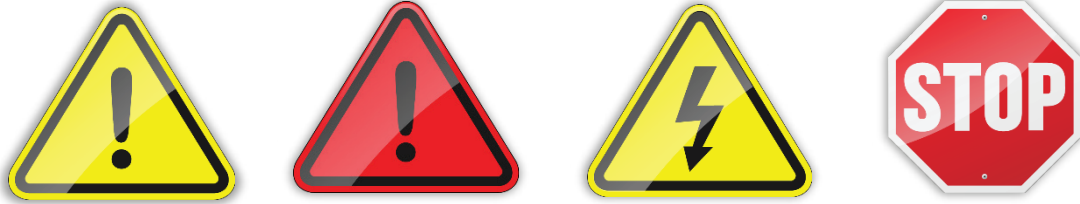

Safety warnings are not in this manual for our benefit; **they are for you.** Please follow them carefully.

You must read, understand, and comply with all of these safety instructions in order to protect your life and safety, and to prevent equipment problems or damage. Failure to follow the instructions in this chapter may void equipment warranties.



We make every effort to remove sharp edges from our products. However, we highly recommend wearing gloves when handling metal parts in order to avoid sharp edges.

Before you begin any digging for the post, you **MUST** make absolutely sure that there are no buried lines in the area that you'll be working. Buried utility lines can be **LETHAL** if struck and / or damaged.

**Use your head and PLEASE do not become a statistic!**



### Note:

Locating services are normally provided for **FREE** by the utility company or one of their contractors. The Utility Company will not normally locate privately-owned lines, such as propane lines or wiring buried between buildings on your property.

# Main Components & Overview

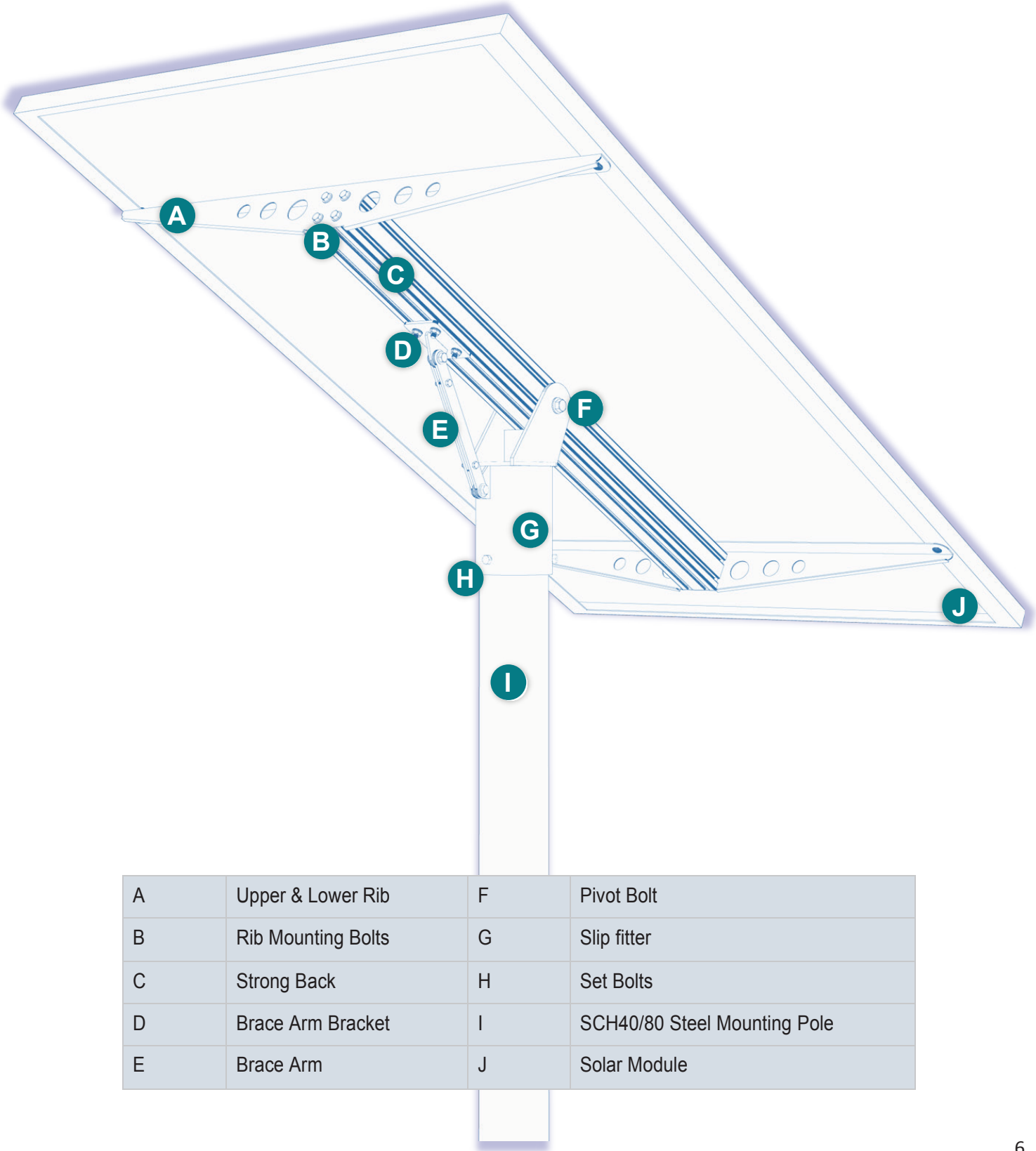

A	Upper & Lower Rib	F	Pivot Bolt
B	Rib Mounting Bolts	G	Slip fitter
C	Strong Back	H	Set Bolts
D	Brace Arm Bracket	I	SCH40/80 Steel Mounting Pole
E	Brace Arm	J	Solar Module

## Locating the Array

### Avoiding shading on your panel(s)

The avoidance of shading on your solar array cannot be stressed enough. Even a small amount of shade on part of the panel will reduce the power output of the panel, which means your aerator won't pump as much air. Sunlight is the fuel that drives the system. Shading on a solar panel is the same as pinching off the fuel line on your car.

In order to get the most from your array, we need to maximize exposure to sunlight during the "solar window" each day. The Solar Window is roughly 9am to 3pm, with peak production occurring between the hours of 10am and 2pm. Roughly speaking, this is represented by a 45° East to 45° West clear area as shown in the diagram below. This 6-hr time frame accounts for approximately 75% of total daily solar energy production.

If you need help or have questions about siting your array, **CALL US** & we will help you.

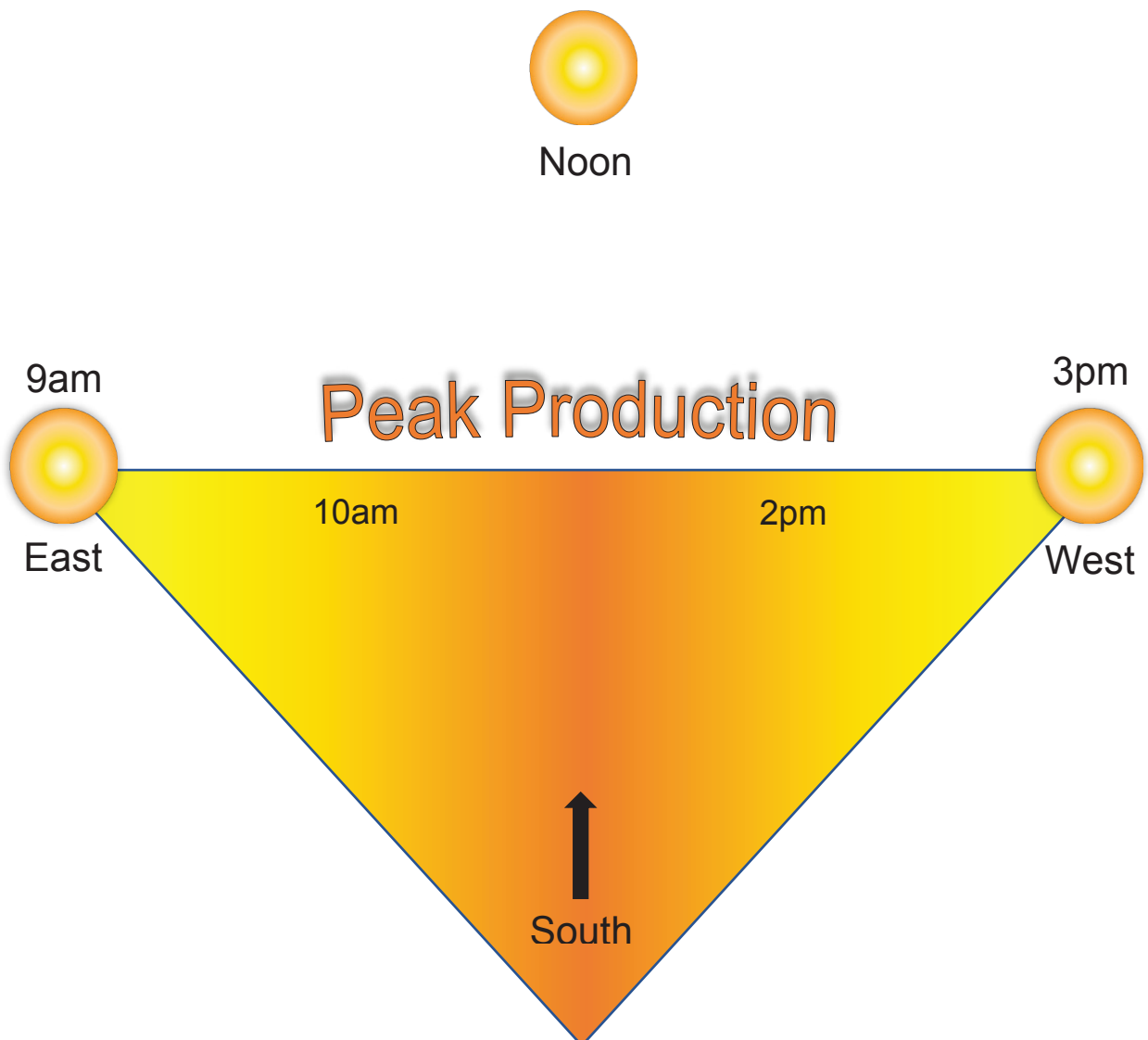

## Trees & Vegetation to the South

In addition to the East-West solar window (9am to 3pm), you also need to consider possible obstructions to the South of the array that will change over time. Trees are the primary concern when it comes to reduced power output due to shading in the future. If your array is installed with trees to the South, you must consider how large the tree will become in the future.

The physical distance from the array to the trees is a very important factor to consider. The farther South you are located, the higher the sun's path throughout the year. A higher sun angle means that objects like trees can be closer to the array. Contact us if you need any help with siting your array.

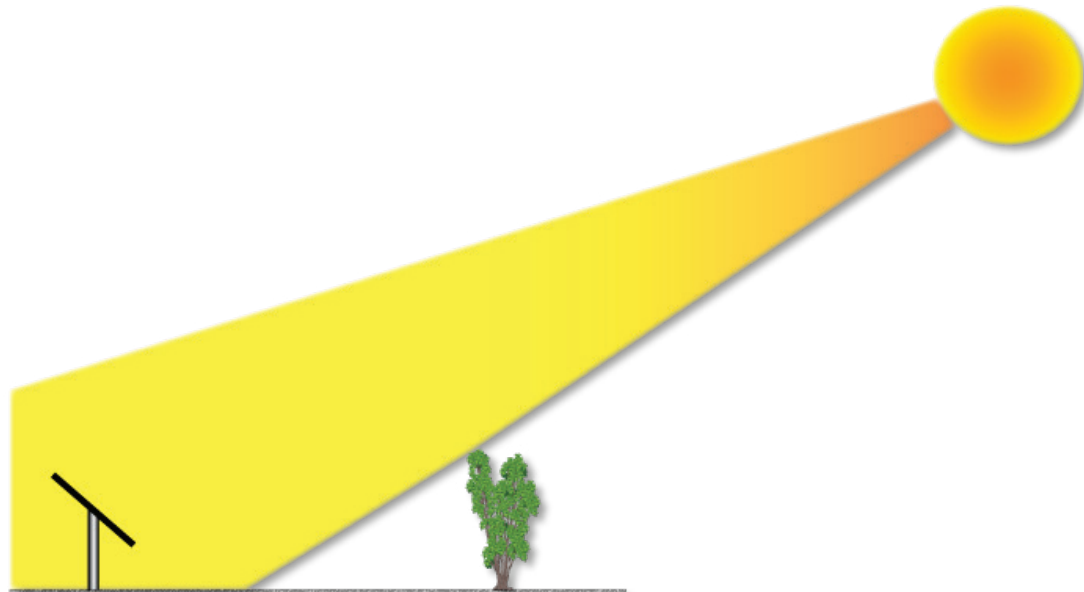

Today

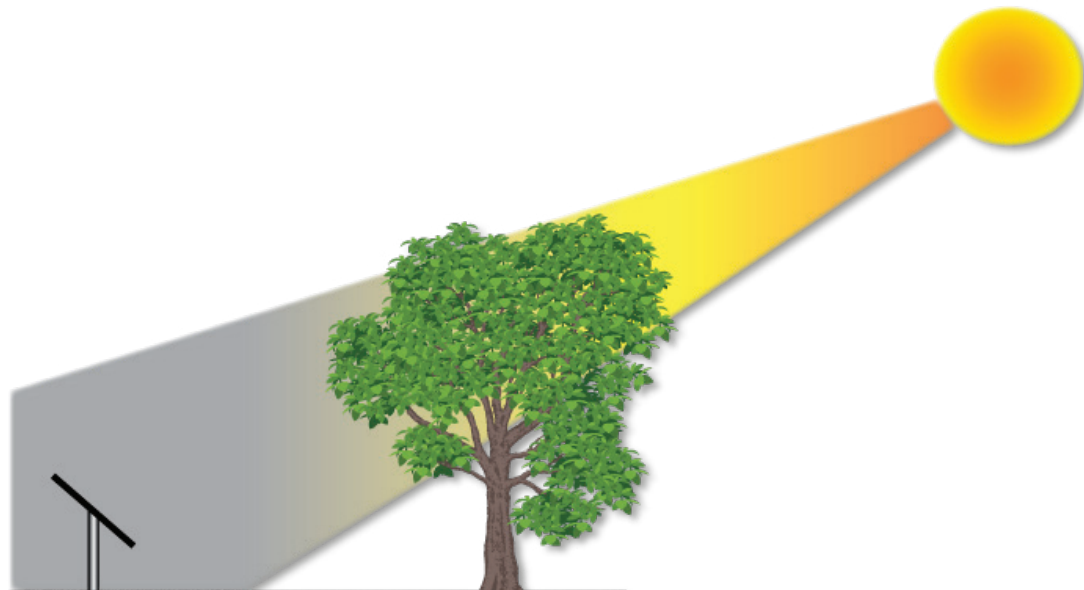

10 years from now



## Pole & Foundation Installation

Now that you've selected a shade-free location for your array and made sure that there are no buried utilities, you're ready to install the steel pole. This is a very straight-forward process consisting of the following steps:

1. Excavate a post hole roughly to the dimensions shown in the foundation diagram below. This is most often accomplished using a regular Post Hole Digger, but an Earth Auger or any other suitable method may be used.
2. OPTIONAL – Pour 3-4" of gravel into the bottom of the hole. This will allow for drainage.
3. Set the pole into the hole, taking care to get it as centered in the hole as possible.  
NOTE: Steel poles are HEAVY. Have someone help you set the pole into the hole.
4. Plumb the post using a level(s) and brace in place using lumber or other suitable material.
5. Fill the hole with concrete with a minimum strength of 4000 PSI. This is a standard minimum rating for concrete today. If you choose to hand-mix bags of Redi-Mix, you may consider adding straight Portland Cement to the mix.

In a wheelbarrow or mixing tub, add 2 bags of Redi-Mix and 1 shovel-full of Portland Cement. Add water & mix thoroughly until you've achieved a smooth, pourable consistency. Do not add too much water.

Fill the hole to within 4-6" of grade. This area can then be filled in with soil.

You should allow the concrete to cure for at least 24 hours before removing braces.

Adjust the pole to plumb using a standard construction level. Check the pole in 2 locations 90° apart as shown.

Brace the pole with any suitable lumber or readily-available bracing material.

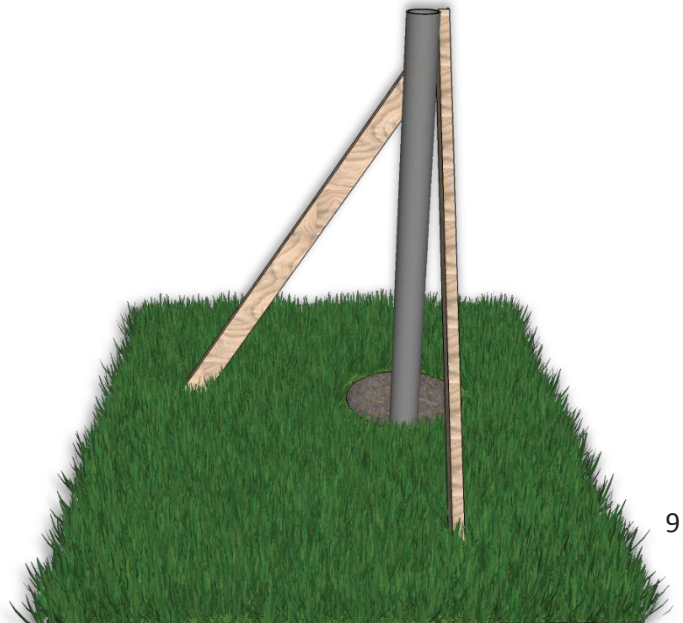
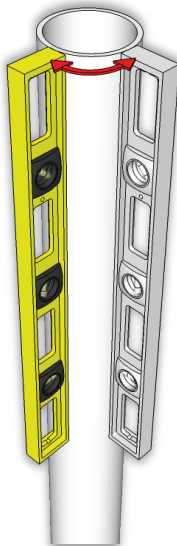

# Foundation Diagram

**Note:**

An example foundation drawing is shown below. While suitable for most locations, Scott Aeraor cannot ensure that this design will be adequate for all installations. The installer is responsible for verifying that the foundation is adequate and meets all local code requirements for wind, snow and seismic loads.

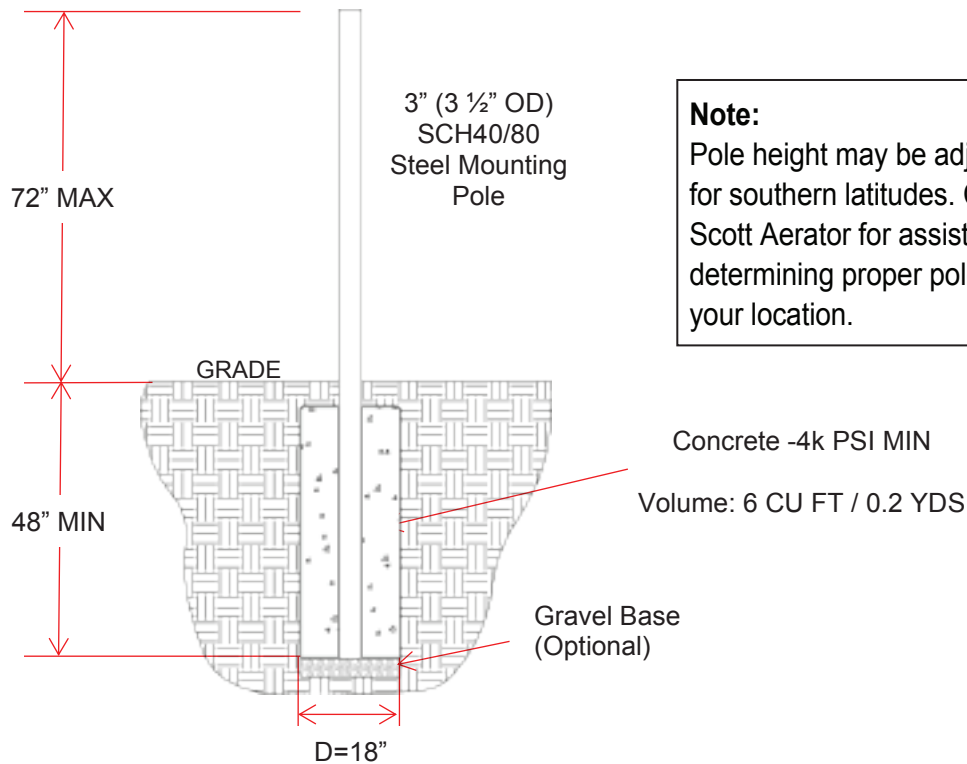

**Note:**

Pole height may be adjusted down for southern latitudes. Consult with Scott Aerator for assistance in determining proper pole height for your location.

**Optional Step**

If your array will be located in an area that is subjected to high winds, you may consider adding Anti-Rotation Rods to the pole. This is a simple modification to the lower part of the pole and prevents high winds from being able to rotate the pole loose from the concrete.

1. Approximately 2' from the bottom of the pole drill a 1/2" hole straight through both sides of the pipe.
2. Move up 2-4" and rotate the pipe 90°. Drill a 2<sup>nd</sup> set of holes straight through again.
3. Insert a 1/2"x12" length of steel rod through each pair of holes.

The holes and rods DO NOT need to be tight. They simply need to pass through the pole.

Hole and Rod sizes can be adjusted to work with other sizes of materials.

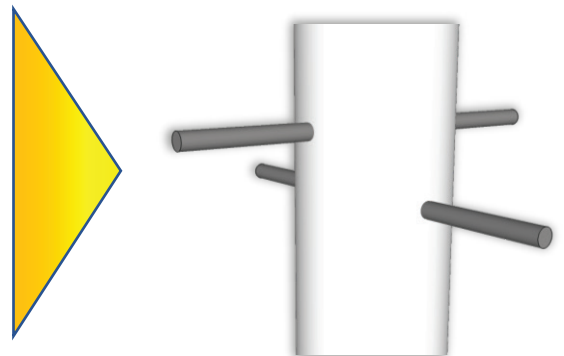

## Array Assembly

Once the foundation has been allowed to cure and the braces removed, the array can be assembled. Unpack the Slipfitter Assembly and slip it onto the pole so that the 'fin' on the one side is aimed due **North**. The set bolts may need to be removed to set the assembly on the pole. Once in place, fully tighten the set bolts to secure the mount in place.

1. Unpack the Slip-Fitter Assembly and lower it onto the top of the pole.

You'll need to back the Set Bolts out in order to install the Slip-Fitter onto the pole.

**MAKE SURE** that the Angle Brace Tab is aimed **DUE NORTH**.

2. Once the Slip-Fitter is in place and properly aligned, securely tighten the Set Bolts.

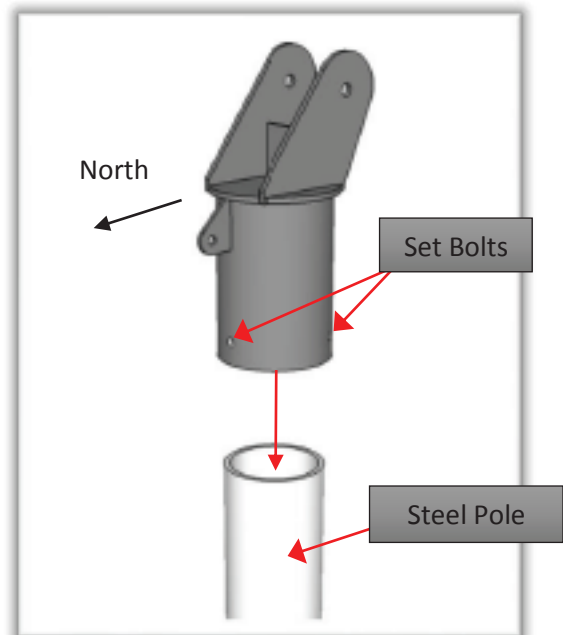

### ***Optional Step for High-Wind Areas***

There is an extra 3/8" hole through the Slip-Fitter located directly above the North Set Bolt. This hole is for an Optional Roll Pin in extremely high-wind areas.

1. Using the hole in the Slip-Fitter as a guide, drill a hole through the side wall of the pipe. The hole has been sized for a 3/8" pin.
2. Insert a 3/8" Roll Pin into the hole.
3. Tap/drive the pin through the Slip-Fitter and through the pole until it is nearly flush. Take care not to damage the Slip-Fitter's paint.

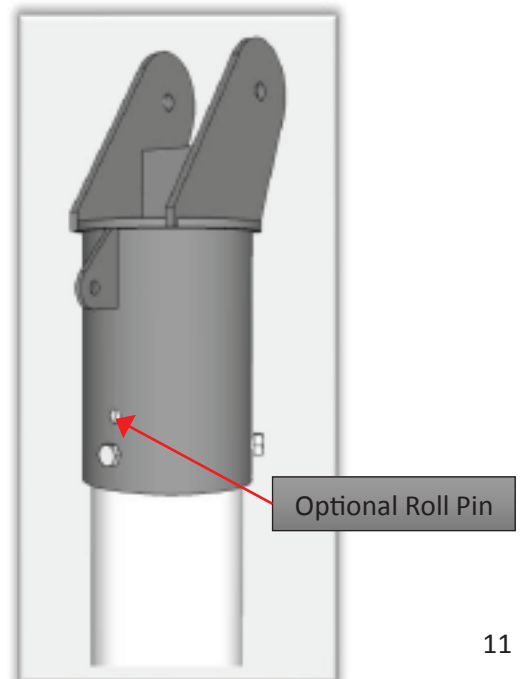

## Strong-Back & Angle Brace

**Note:** The aluminum Strong-Back has been factory cut-to-length for use with Scott Aerator supplied solar panels. If another source of module is used, the beam may need to be trimmed to a shorter length. Most 60-Cell modules will have their holes spaced between 36" and 44" apart. Both ends of the Rail will need to be trimmed to ensure the Pivot Hole remains centered. A standard miter saw may be used to cut the aluminum. Remember to secure/clamp the workpiece and CUT SLOWLY.

**To calculate:** Strong-Back Length = Module Hole-to-Hole center distance + 1.5"  
If you have any questions at all, please give us a call & we will help you with it.

1. Set the Strong-Back into the Slip-Fitter Assembly as shown below. Line up the holes and insert the 1/2"-13 Pivot Bolt through the Slip-Fitter and Strong-Back. Hand Tighten ONLY. The Rail needs to be able to pivot in order to set the array elevation later.
2. Slide the pre-assembled Angle Brace Bracket into the bottom **North** end of the Strong-Back as shown.
3. Remove the bolt from the lower end of the Brace Arm.
4. Swing the Angle Brace upward so that the lower end can be fastened onto the Angle Brace Mounting Tab on the North side of the Slip-Fitter Assembly.
5. Insert the bolt (previously removed) back through the lower hole in the Brace Arm and mounting tab. Tighten the nut/bolt only finger-tight at this time.
6. Tighten the Angle Brace Bracket bolts just tight enough to hold the StrongBack in place for assembly.

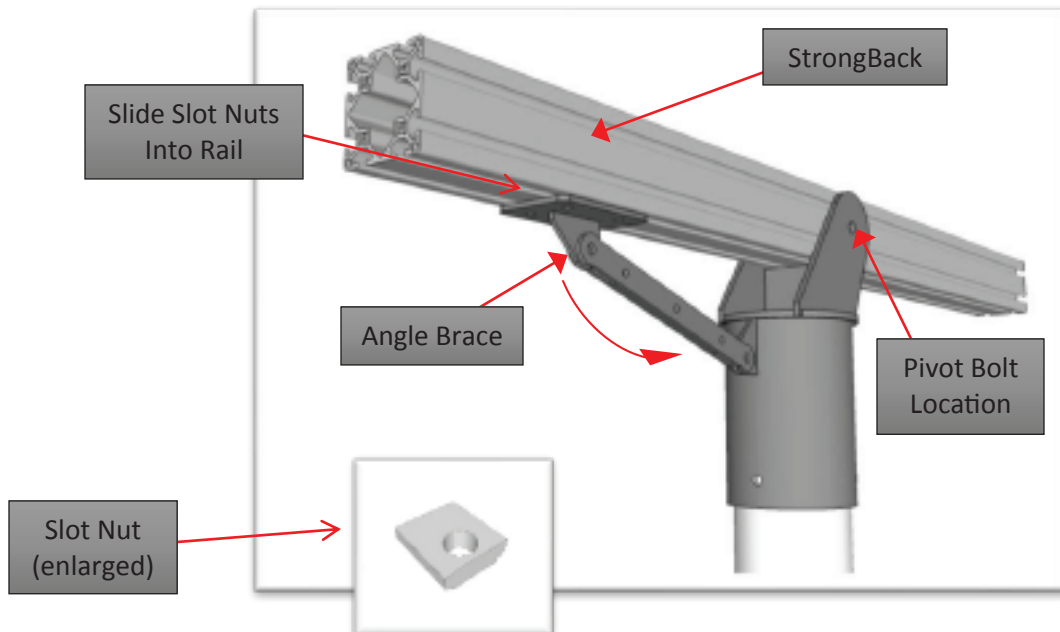

## 3160 – Installing the Mounting Ribs

**If you have a dual 60-Cell mount (3260 TOP), jump to Page 14.**

---

Before the Panels can be installed, the Ribs will need to be installed on both ends of the Strong-Back.

The Ribs are fastened to the Strong-Back using four (4) 5/16-18 hex bolts & lock-washers per rib.

1. Install the Ribs as shown below and tighten all 8 bolts securely.

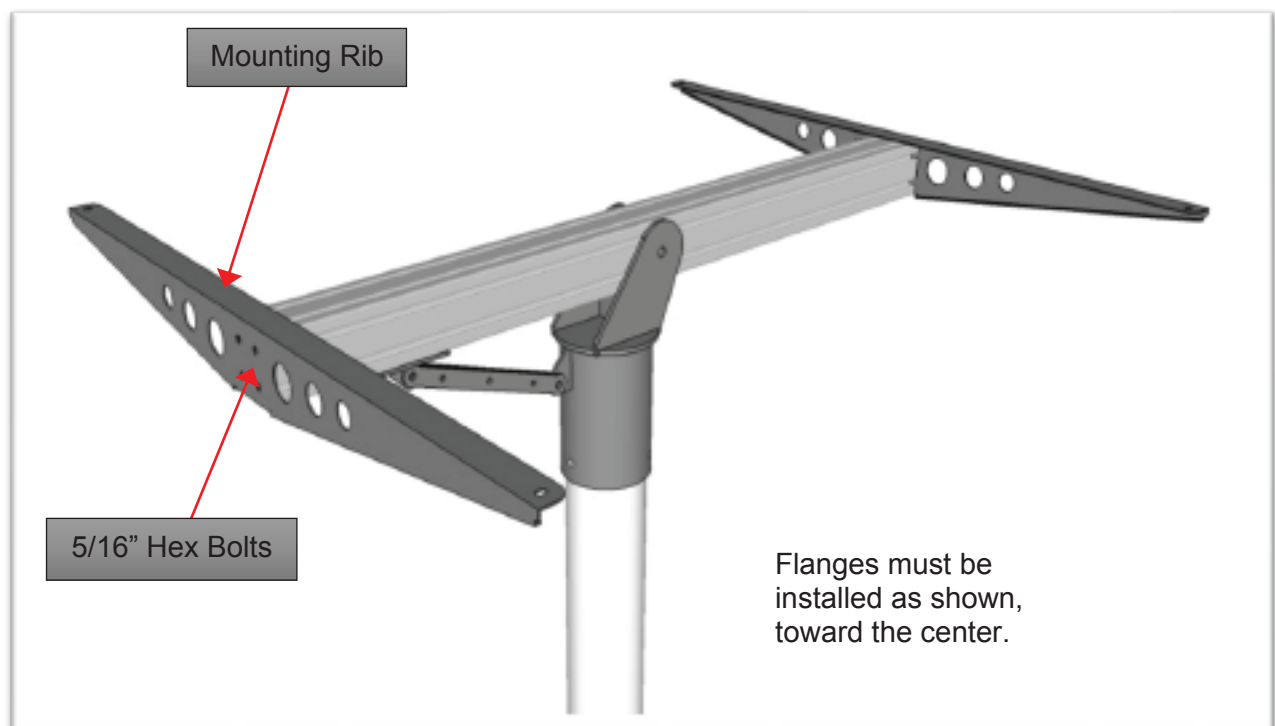

## 3160 – Installing the Panel

1. Carefully unpack your solar module and set it onto the Ribs with the Junction Box on the North end as shown below.
2. Line up the mounting holes on the back side of the module frame with the holes in the Ribs.
3. Insert a 5/16-18 Hex bolt with a flat washer from the bottom of the Rib up through the mounting hole in the back of the module frame.
4. Install a Serrated-Flange nut onto the bolt from the top side (under the module)
5. Once all 4 bolts have been installed, tighten them securely. The serrated nuts should actually “dig in” to the aluminum module frame.

Refer to the diagram below for module installation.

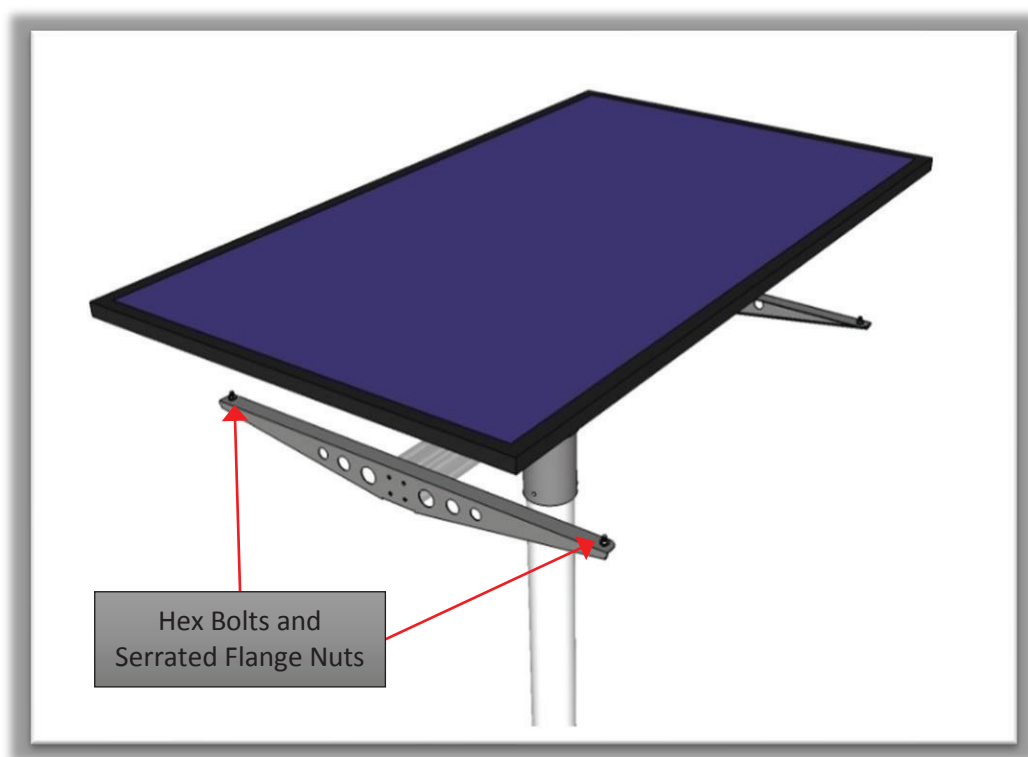

Skip the next Section and jump to Section 13 – Setting Array Elevation

## 3260 – Installing the Panel Rails

2-Module mounts (Model #3260) include extruded aluminum Mounting Rails.

The Rails are fastened to the Strong-Back using a Rail Bracket and four (4) 5/16"-18 hex bolts with lock-washers per end.

1. Position the Bracket so that the formed flanges are facing inward towards the center of the array and line up the 4 bottom mounting holes with the end of the Strong-Back.
2. Install four (4) 5/16"-18 hex bolts with split-lock washers through the Rail Bracket and into the 4 tapped holes in the end of the Strong-Back. Tighten Finger Tight Only at this point.
3. Install four (4) carriage-head bolts, threads aiming down, into the holes on the top flange of the Rail Bracket. Add a lock-washer and start a hex nut onto the threads on the bottom side of the flange. Leave the nut at the end of the threads so the bolt is loose.
4. Slide the Rails in across the top flange of the End Bracket so the carriage bolts slip into the bottom slot. Make sure the two Rails meet at the center of the End Bracket.
5. Once each Rail is centered, tighten all hardware securely.
6. Repeat this process for the opposite Rail Bracket.

Refer to the diagram below for details.

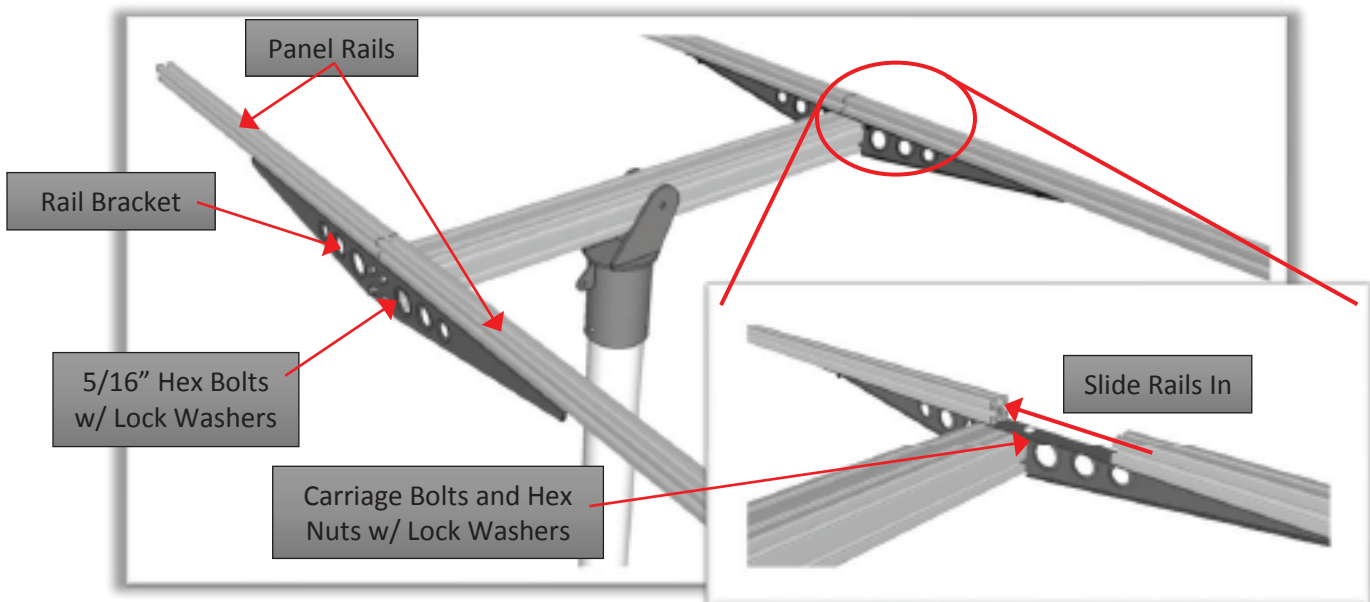

## 3260 – Installing the Panels

1. Carefully unpack your solar modules.
2. Slide 4 carriage-head bolts into the top slot on each aluminum rail. Space the bolts so that there is 1 bolt at each end of the rail and 2 bolts near the center.
3. One at a time, set a module onto the Rails with the Junction Box (the wiring box on the bottom face of the panel) on the North end.
4. Adjust the position of the carriage-head bolts as needed so that they go up through the mounting holes in the back of the module frame.
5. Install a Serrated-Flange nut onto the 4 bolts from the top side (under the module)
6. Do not tighten the nuts yet.
7. Repeat this process for the 2<sup>nd</sup> solar module.
8. After both modules have been mounted, adjust them as needed so that the outside edges of the modules are flush with the ends of the aluminum extrusions.
9. Check to make sure that the modules are as square to each other as possible. Adjust as needed.
10. After both modules have been installed and checked for square, securely tighten all 8 of the serrated flange nuts & bolts. The serrated nuts should actually “dig in” to the aluminum module frame.

Refer to the diagram below for details.

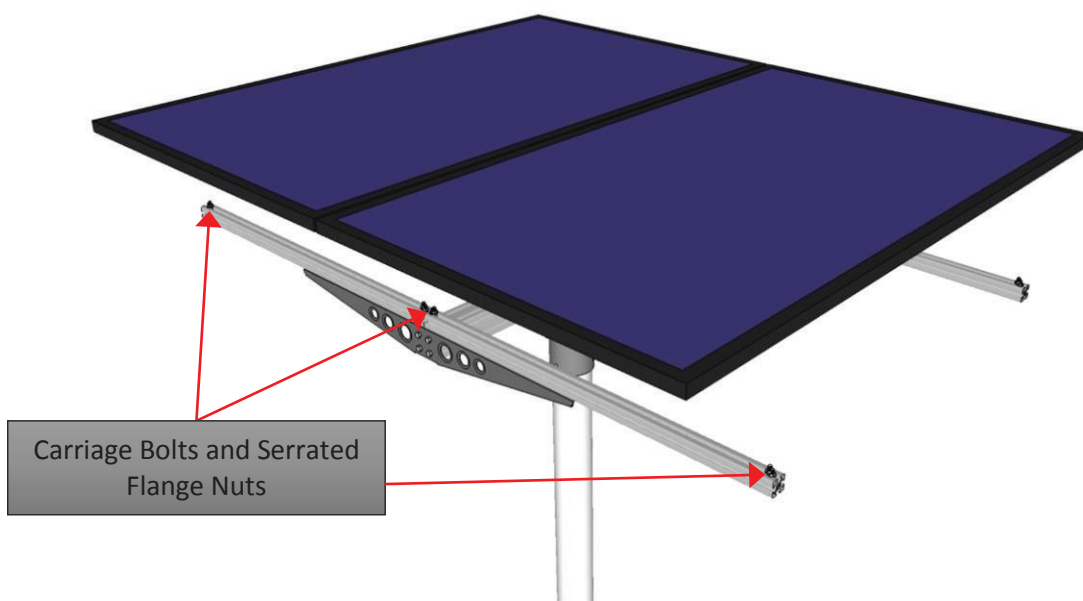



## Setting Array Elevation

Your last assembly step is to set the elevation of the array. The optimum year-round tilt angle for a solar array is determined by your latitude North of the equator. You can find your latitude in a multitude of different ways.

1. A GPS or Smart-Phone App
2. Google Earth
3. Almost any mapping site like Google Maps, Bing Maps, MapQuest, etc.
4. The map on the following page will give you a rough idea.

Latitudes for various cities in the U.S.	
City	Latitude North
Minneapolis, MN	44°
Des Moines, IA	41°
Tulsa, OK	36°
Chattanooga, TN	35°
Dallas, TX	32°
Cuero, TX	29°
Orlando, FL	28°

Although accuracy is nice, please keep in mind that if you are off by 5-10°, it will not be the end of the world. In fact, it will likely be barely noticeable.

Once you've determined what angle you'd like to set your array to, it's time to tilt it up.

1. Loosen the 4 Brace Arm Bracket bolts on the bottom of the Strong-Back.
2. Tilt the array to your desired elevation.
3. Securely tighten the Brace Arm Bracket bolts
4. Securely tighten the hardware on the upper & lower end of the Brace Arm.
5. Securely tighten the large Main Pivot Bolt. The "ears" on either side of the Strong-Back should clamp tightly against the side of the Strong-Back.

There are a variety of ways to measure the angle of your array, most of which are very inexpensive and some are free.



Usually Free Smart Phone App



Generally, \$10 or Less



Range from \$35 to \$125

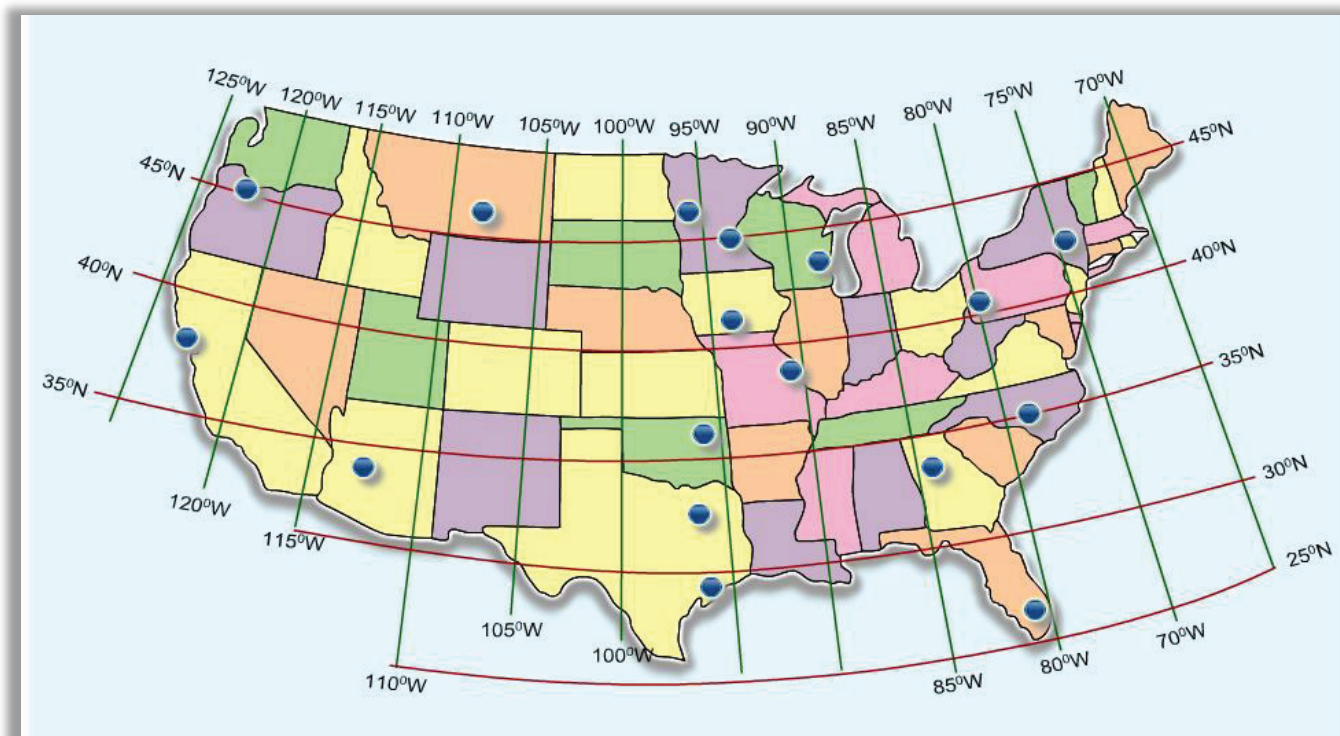

A few notes on Summer vs Winter Elevation Settings:

The previous page briefly describes how to find the optimum “year-round” array tilt. While this setting may work for nearly all situations, it may be possible that a different tilt angle is needed for specific situations.

For example, someone living in Wisconsin or Maine using a US Solar Mounts SD Aerator may be more interested in keeping an area of their lake free of ice in the Winter. De-icing around gates or spillways could be very important to them. Either way, folks in the North will have to deal with snow accumulation on the array. They may want to INCREASE (steepen) the tilt angle to favor Winter production when the sun angle is very low. The increased tilt angle will also assist with shedding snow from the array. It is very common to have tilt angles of 50°-60° on Northern installations.

Installation sites in the Southern part of the US may have completely different solar production goals at different times of the year. For instance, if the primary goal is to prevent fish kill in a farm tank during the super-hot months of July & August, they may want to DECREASE (flatten) the tilt angle of their array for greater summertime production. If they could, the Largemouth in your tank would thank you for it.

If you would really like to “see” the effect that changing tilt angle has, go out and play with the array! Pick a nice, sunny day around noon. It only takes a minute to loosen the Angle Brace Bracket and the Main Pivot Bolt. Make sure to tighten everything up again when you’re finished.

## Array Grounding

A properly installed solar array of any size or configuration needs to be solidly grounded. You should not rely only on the mounting pole for proper or effective grounding.

Grounding of your pole top should accomplish the following:

1. Bonding the solar module frame to the rack itself, and
2. Grounding the rack to an Earth Ground via a Grounding Electrode Conductor (GEC).

The components required to properly ground an array may vary from one jurisdiction to another and are normally supplied & installed by the installer.

The diagrams below show the basic grounding system. The GEC is shown in green for illustration purposes but is normally a bare #8 stranded copper conductor.

Note: Insulated wire can be used but must be stripped at each termination point.

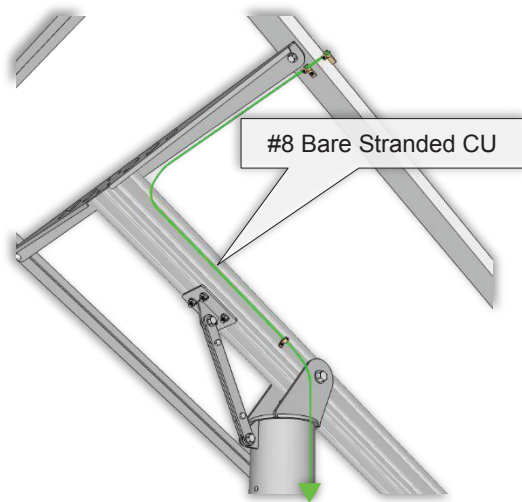

Single Panel GND Wire Route

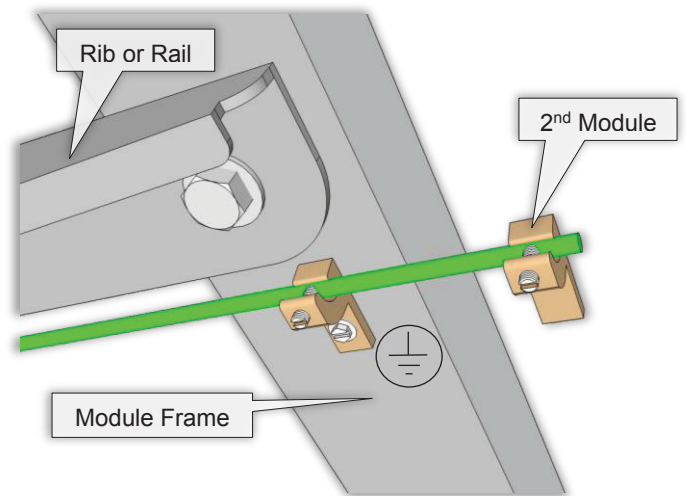

Module Frame Ground Lug

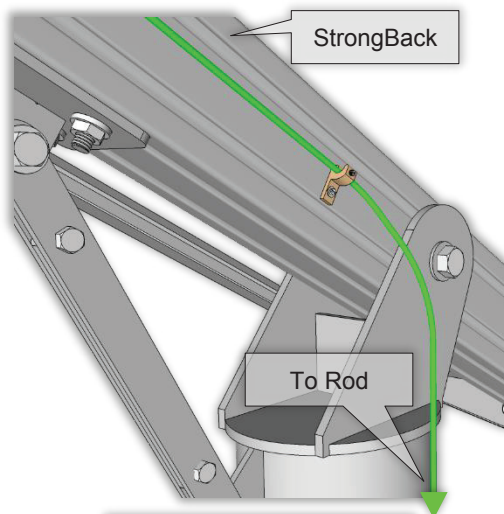

StrongBack Ground Lug

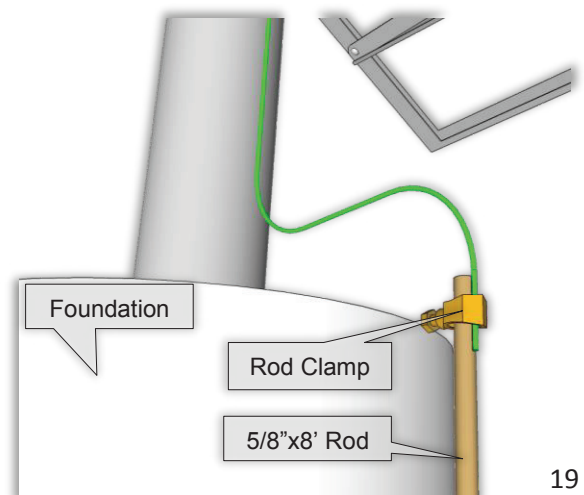

Ground Rod Clamp

**One last check...**

Take a minute to go over your array one more time to check for loose hardware.

Don't be afraid to bang on it a little bit & listen for loose parts.

Put your hands on each fastener one more time.

It's far better to find a loose bolt now versus finding a solar panel laying in your yard after a wind storm.



Completed 3160



Completed 3260

Assembly of the mount is now complete. The installer is responsible for ensuring proper wiring of the modules for the given project. If being used for a Scott Aerator SLA, refer to your SD Series Instruction Manual for array wiring.

If you have any questions about the installation of your solar array, please don't hesitate to contact us. We'll answer your questions & walk you through any parts that you need help with.



13245 Barry Street, Holland, MI 49424  
616-392-8882 | 800-WATER-45 (800-928-3745) | Fax: 616-392-8860  
information@scottaerator.com