

# EMC TEST REPORT

On Behalf of

Prepared For :	<b>Yiwu wenmei import &amp; export Co., Ltd</b>  12 floor, 7 building No.788 Cheng Dian South Road Yiwu city Z hejiang
Trade Mark :	<b>N/A</b>
Product Name :	<b>Tattoo Machine</b>
Model(s) :	<b>TM-36, TM-104, TM-105, TM-109, TM-163, TM-147, TM-148, TM-149, TM-150, TM-406, TM-421, TM-821, TM-822, TM-824, TM-1201, TM-1202, TM-340, TM-341, TM-342, TM-378, TM-379, TM-380, TM-381, TM-382, TM-383, TM-384, TM-385, TM-7501, TM-7531, TM-509, TM-5112, TM-5327A, TM-5327B, TM-5338, TM-5339, TM-5340, TM-5341, TM-5342, TM-5603, TM-763, TM-764, T1-A, T1-B, T1-C, G1-A, G1-B, G2-A, T3-A, T3-B, T2F-A, T2F-B, T2, T2S, T2K-A, T2K-B, T2K-C, M1-A, M1-B, M2-A, M2-B, M1S-A, M1S-B, M1S-C</b>
Prepared By:	<b>Shenzhen ZTS Testing Service Co., Ltd.</b>  808, Building 1, 7th Industrial Zone, Yulv Community, Yutang Street, Guangming District, Shenzhen, Guangdong, China Tel: 400-8788-298 Tel:0755-23245950 Web: www.zts-test.com Email: zts@zts-test.com
Test Date:	<b>Jul. 09, 2021 - Jul. 15, 2021</b>
Date of Report:	<b>Jul. 15, 2021</b>
Report No. :	<b>ZTS21070902URE</b>



**Note:** This test report is limited to the above client company and the product model only. It may not be duplicated without prior written consent of Shenzhen ZTS Testing Service Co., Ltd.

## TABLE OF CONTENT

### Test Report Description

<b>1. GENERAL INFORMATION .....</b>	<b>5</b>
1.1. Description of Device (EUT).....	5
1.2. Test Standards .....	5
1.3. Test Summary .....	6
1.4. Test Methodology .....	7
1.5. Test Facility .....	7
1.6. Measurement Uncertainty.....	7
<b>2. MEASURING DEVICE AND TEST EQUIPMENT.....</b>	<b>8</b>
2.1. For Power Line Conducted Emission .....	8
2.2. For Radiated Emission Measurement .....	8
2.3. For Harmonic Current / Flicker Measurement.....	8
2.4. For Electrostatic Discharge Immunity Test.....	8
2.5. For Electrical Fast Transient /Burst Immunity Test .....	9
2.6. For Surge Immunity Test .....	9
2.7. For Injected Current Susceptibility Test .....	9
2.8. For Magnetic Field Immunity Test .....	9
2.9. For Voltage Dips and Interruptions Test .....	9
<b>3. POWER LINE CONDUCTED EMISSION MEASUREMENT.....</b>	<b>10</b>
3.1. Block Diagram of Test Setup.....	10
3.2. Measuring Standard .....	10
3.3. EUT Configuration on Measurement.....	10
3.4. Operating Condition of EUT .....	10
3.5. Test Procedure .....	11
3.6. Measuring Results .....	11
<b>4. RADIATED EMISSION MEASUREMENT .....</b>	<b>12</b>
4.1. Block Diagram of Test .....	12
4.2. Measuring Standard .....	12
4.3. Radiated Emission Limits .....	12
4.4. EUT Configuration on Test.....	12
4.5. Operating Condition of EUT .....	13
4.6. Test Procedure .....	13
4.7. Measuring Results .....	13
<b>5. HARMONIC CURRENT EMISSION MEASUREMENT.....</b>	<b>16</b>
5.1. Block Diagram of Test Setup.....	16
5.2. Measuring Standard .....	16
5.3. Operation Condition of EUT .....	16
5.4. Measuring Results .....	16
<b>6. VOLTAGE FLUCTUATION AND FLICKER MEASUREMENT .....</b>	<b>17</b>
6.1. Block Diagram of Test Setup.....	17
6.2. Measuring Standard .....	17
6.3. Operation Condition of EUT .....	17
6.4. Measuring Results .....	17
<b>7. ELECTROSTATIC DISCHARGE IMMUNITY TEST .....</b>	<b>18</b>
7.1. Block Diagram of Test Setup.....	18
7.2. Test Standard.....	18
7.3. Severity Levels and Performance Criterion.....	18
7.4. EUT Configuration .....	18
7.5. Operating Condition of EUT .....	19
7.6. Test Procedure .....	19
7.7. Test Results.....	19
<b>8. RF FIELD STRENGTH SUSCEPTIBILITY TEST .....</b>	<b>21</b>



8.1. Block Diagram of Test ..... 21

8.2. Test Standard..... 21

8.3. Severity Levels and Performance Criterion ..... 22

8.4. EUT Configuration on Test..... 22

8.5. Operating Condition of EUT ..... 22

8.6. Test Procedure ..... 22

8.7. Test Results ..... 22

**9. ELECTRICAL FAST TRANSIENT/BURST IMMUNITY TEST..... 24**

9.1. Block Diagram of Test Setup ..... 24

9.2. Test Standard..... 24

9.3. Severity Levels and Performance Criterion ..... 24

9.4. EUT Configuration ..... 24

9.5. Operating Condition of EUT ..... 25

9.6. Test Procedure ..... 25

9.7. Test Result ..... 25

**10. NITTY TEST ..... 26**

10.1. Block Diagram of Test Setup ..... 26

10.2. Test Standard ..... 26

10.3. Severity Levels and Performance Criterion..... 26

10.4. EUT Configuration ..... 26

10.5. Operating Condition of EUT ..... 27

10.6. Test Procedure ..... 27

10.7. Test Result ..... 27

**11. INJECTED CURRENTS SUSCEPTIBILITY TEST ..... 28**

11.1. Block Diagram of Test Setup ..... 28

11.2. Test Standard ..... 28

11.3. Severity Levels and Performance Criterion..... 28

11.4. EUT Configuration ..... 28

11.5. Operating Condition of EUT ..... 29

11.6. Test Procedure ..... 29

11.7. Test Results..... 29

**12. MAGNETIC FIELD SUSCEPTIBILITY TEST ..... 30**

12.1. Block Diagram of Test..... 30

12.2. Test Standard ..... 30

12.3. Severity Levels and Performance Criterion..... 30

12.4. EUT Configuration on Test..... 30

12.5. Test Procedure ..... 31

12.6. Test Results..... 31

**13. VOLTAGE DIPS AND INTERRUPTIONS TEST ..... 32**

13.1. Block Diagram of Test Setup..... 32

13.2. Test Standard ..... 32

13.3. Severity Levels and Performance Criterion..... 32

13.4. EUT Configuration ..... 32

13.5. Operating Condition of EUT ..... 33

13.6. Test Procedure ..... 33

13.7. Test Result ..... 33

APPENDIX I (Photos of EUT)

## TEST REPORT DECLARATION

Applicant	:	<b>Yiwu wenmei import &amp; export Co., Ltd</b>
Address :	:	12 floor, 7 building No.788 Cheng Dian South Road Yiwu city Zhejiang
Manufacturer:	:	<b>Yiwu wenmei import &amp; export Co., Ltd</b>
Address :	:	12 floor, 7 building No.788 Cheng Dian South Road Yiwu city Zhejiang
EUT Description :	:	<b>Tattoo Machine</b>
Model Number	:	<b>TM-36</b>
Rating(s)	:	DC 30V 6A, 5-50W

Test Standards:

**EN 61000-6-3: 2007+A1: 2011+AC: 2012****EN 61000-6-1: 2019****EN 61000-3-2: 2019****EN 61000-3-3: 2013+A1:2019**

The EUT described above is tested by ZTS Testing Service Co., Ltd. EMC Laboratory to determine the maximum emissions from the EUT and ensure the EUT to be compliance with the immunity requirements of the EUT. Shenzhen ZTS Testing Service Co., Ltd. is assumed full responsibility for the accuracy of the test results. Also, this report shows that the EUT technically complies with the 2014/30/EU directive and its amendment requirements.

The test report is valid for above tested sample only and shall not be reproduced in part without written approval of the laboratory.

Date of Test:

**Jul. 09, 2021 - Jul. 15, 2021**

Prepared by (Engineer) :

Jimmy He

Reviewer by (Quality Manager) :

Tony mo

Approved by (Manager) :

Bart Yang



# 1. GENERAL INFORMATION

## 1.1. Description of Device (EUT)

EUT : Tattoo Machine

Model : TM-36

Supplementary Model : TM-104, TM-105, TM-109, TM-163, TM-147, TM-148, TM-149, TM-150, TM-406, TM-421, TM-821, TM-822, TM-824, TM-1201, TM-1202, TM-340, TM-341, TM-342, TM-378, TM-379, TM-380, TM-381, TM-382, TM-383, TM-384, TM-385, TM-7501, TM-7531, TM-509, TM-5112, TM-5327A, TM-5327B, TM-5338, TM-5339, TM-5340, TM-5341, TM-5342, TM-5603, TM-763, TM-764, T1-A, T1-B, T1-C, G1-A, G1-B, G2-A, T3-A, T3-B, T2F-A, T2F-B, T2, T2S, T2K-A, T2K-B, T2K-C, M1-A, M1-B, M2-A, M2-B, M1S-A, M1S-B, M1S-C

Rating : DC 30V 6A, 5-50W

Applicant : Yiwu wenmei import & export Co., Ltd

Address : 12 floor, 7 building No.788 Cheng Dian South Road Yiwu city Zhejiang

Manufacturer : Yiwu wenmei import & export Co., Ltd

Address : 12 floor, 7 building No.788 Cheng Dian South Road Yiwu city Zhejiang

## 1.2. Test Standards

Test Standards	
EN 61000-6-3: 2007+A1: 2011+AC: 2012	Emission standard for residential. commercial and light-industrial environments
EN 61000-6-1: 2019	Immunity for residential. commercial and light-industrial environments
EN 61000-3-2: 2019	Electromagnetic compatibility(EMC)-Part 3-2:Limits-Limits for harmonic current emissions(equipment input current $\leq 16A$ per phase)
EN 61000-3-3: 2013+A1:2019	Electromagnetic compatibility(EMC)-Part 3-3:Limits-Limitation of voltage changes, Voltage fluctuations and flicker in public low-voltage supply systems. For equipment with Rated current $\leq 16A$ per phase and not subject to conditional connection

### 1.3. Test Summary

For the EUT described above.

Table 1: Tests Carried Out Under EN 61000-6-3: 2007+A1: 2011+AC: 2012

Standard	Test Items	Status
EN 61000-6-3: 2007+A1: 2011+AC: 2012	Disturbance Voltage at The Mains Terminals (150KHz To 30MHz)	×
	Radiated Disturbances (30MHz To 1000MHz)	√

√ Indicates that the test is applicable

×

Table 2: Tests Carried Out Under EN 61000-6-1: 2019

Standard	Test Items	Status
EN61000-4-2:2009	Electrostatic discharge Immunity	√
EN61000-4-3:2006 +A1:2008+A2:2010	Radiated Susceptibility (80MHz to 1GHz)	√
EN61000-4-4:2004+A1:2010	Electrostatic Fast Transient/Burst Immunity	×
EN61000-4-5:2006	Surge Immunity	×
EN61000-4-6:2009	Conducted Susceptibility (150KHz to 80MHz)	×
EN61000-4-8:2010	Power Frequency Magnetic Field Immunity (12.5A)	×
EN61000-4-11:2004	Voltage Dips Short Interruptions Immunity Tests	×

√ Indicates that the test is applicable

√ Indicates that the test is not applicable

Table 3: Tests Carried Out Under EN 61000-3-2: 2019& EN 61000-3-3:2013

Standard	Test Items	Status
EN 61000-3-2: 2019	Harmonic Current	×
EN 61000-3-3: 2013+A1:2019	Voltage Fluctuations	×

√ Indicates that the test is applicable

√ Indicates that the test is not applicable

#### 1.4. Test Methodology

All measurements contained in this report were conducted with CISPR 16-1: 2002, radio disturbance and immunity measuring apparatus, and CISPR16-2, Method of measurement of disturbances and immunity.

All measurement required was performed at laboratory of Shenzhen ZTS Testing Service Co., Ltd.,

#### 1.5. Test Facility

The test facility is recognized, certified, or accredited by the following organizations:

EMC Laboratory has been registered and fully described in a report filed with the (FCC)

The facility also complies with the radiated and AC line conducted test site criteria set forth in CISPR 16-1, CISPR16-2.

#### 1.6. Measurement Uncertainty

Radiation Uncertainty :  $U_r = \pm 3.84\text{dB}$

Conduction Uncertainty :  $U_c = \pm 2.72\text{dB}$

## 2. MEASURING DEVICE AND TEST EQUIPMENT

### 2.1. For Power Line Conducted Emission

Item	Equipment	Manufacturer	Model No.	Serial No.	Last Cal.	Cal. Interval
1.	Test Receiver	Rohde & Schwarz	ESCI EMI TEST RECEIVER	ID:1166.5950K 03-101431-Jq	Nov. 20, 2020	1 Year
2.	L.I.S.N.	Rohde & Schwarz	ESH3-Z5	831.5518.52	Nov. 20, 2020	1 Year
3.	Pulse Limiter	SCHWARZ BECK	VTSD 9561-F	9561-G071	Nov. 20, 2020	1 Year

### 2.2. For Radiated Emission Measurement

Item	Equipment	Manufacturer	Model No.	Serial No.	Last Cal.	Cal. Interval
1.	Spectrum Analyzer	Agilent	E4408B	CFG006	Nov. 20, 2020	1 Year
2.	Test Receiver	Rohde & Schwarz	ESPI TEST RECEIVER	ID:1164.6607K0 3-102109-MH	Nov. 20, 2020	1 Year
3.	Bilog Antenna	Sunol Sciences	Model JB6 Antenna	A090414	Nov. 20, 2020	1 Year
4.	50 Coaxial Switch	Anritsu Corp	MP59B	6100237248	/	/
5.	Horn Ant	Schwarzbeck	Model DRH-118	A091114	Nov. 20, 2020	1 Year

### 2.3. For Harmonic Current / Flicker Measurement

Item	Equipment	Manufacturer	Model No.	Serial No.	Last Cal.	Cal. Interval
1.	Signal Conditioning Unit	SCHAFFNER	CCN1000-1	72314	Nov. 20, 2020	1 Year
2.	Power Supply	SCHAFFNER	NSG1007-3-240	56110	Nov. 20, 2020	1 Year

### 2.4. For Electrostatic Discharge Immunity Test

Item	Equipment	Manufacturer	Model No.	Serial No.	Last Cal.	Cal. Interval
1.	ESD Tester	PRIMA	ESD610015 A, 0.36W	144305	Nov. 20, 2020	1 Year



## 2.5. For Electrical Fast Transient /Burst Immunity Test

Item	Equipment	Manufacturer	Model No.	Serial No.	Last Cal.	Cal. Interval
1.	Burst Tester	HTEC	HEFT 51	144303	Nov. 20, 2020	1 Year
2.	Coupling Clamp	HAEFELY	IP-4A	147147	/	/

## 2.6. For Surge Immunity Test

Item	Equipment	Manufacturer	Model No.	Serial No.	Last Cal.	Cal. Interval
1.	Surge Tester	HTEC	HCWG	144302	Nov. 20, 2020	1 Year

## 2.7. For Injected Current Susceptibility Test

Item	Equipment	Manufacturer	Model No.	Serial No.	Last Cal.	Cal. Interval
1.	Simulator	SCHAFFNER	NSG2070	1086	Nov. 20, 2020	1 Year
2.	CDN	SCHAFFNER	M016	20812	Nov. 20, 2020	1 Year
3.	CDN	SCHAFFNER	M016	20812	Nov. 20, 2020	1 Year
4.	Attenuator	SCHAFFNER	INA 2070-1	2086	Nov. 20, 2020	1 Year

## 2.8. For Magnetic Field Immunity Test

Item	Equipment	Manufacturer	Model No.	Serial No.	Last Cal.	Cal. Interval
1.	Magnetic Field Tester	HTEC	HPFM T	144301	Nov. 20, 2020	1 Year

## 2.9. For Voltage Dips and Interruptions Test

Item	Equipment	Manufacturer	Model No.	Serial No.	Last Cal.	Cal. Interval
1.	Dips Tester	HTEC	HPFS	144304	Nov. 20, 2020	1 Year

### 3. POWER LINE CONDUCTED EMISSION MEASUREMENT

#### 3.1. Block Diagram of Test Setup

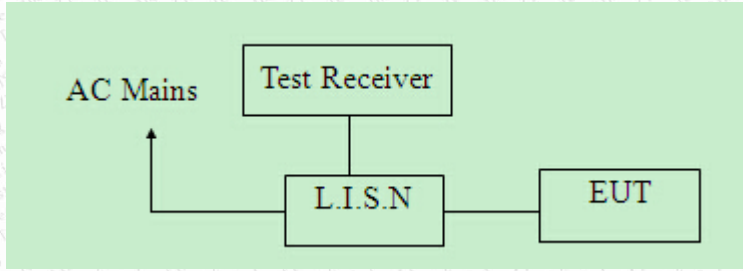

#### 3.2. Measuring Standard

EN 61000-6-3: 2007+A1: 2011+AC: 2012

Power Line Conducted Emission Limits (Class B)

Frequency (MHz)	Limit (dB $\mu$ V)	
	Quasi-peak Level	Average Level
0.15 ~ 0.50	66.0 ~ 56.0 *	56.0 ~ 46.0 *
0.50 ~ 5.00	56.0	46.0
5.00 ~ 30.00	60.0	50.0

NOTE1-The lower limit shall apply at the transition frequencies.  
 NOTE2-The limit decreases linearly with the logarithm of the frequency in the range 0.15MHz to 0.50MHz.

#### 3.3. EUT Configuration on Measurement

The following equipments are installed on Conducted Emission Measurement to meet EN61000-6-3 requirements and operating in a manner which tends to maximize its emission characteristics in a normal application.

- EUT : N/A
- Model Number : N/A
- Serial Number : N/A

#### 3.4. Operating Condition of EUT

- 3.4.1. Setup the EUT as shown on Section 3.1.
- 3.4.2. Turn on the power of all equipments.
- 3.4.3. Let the EUT work in measuring mode (On) and measure it.

### 3.5. Test Procedure

The EUT is put on the plane 0.8m high above the ground by insulating support and connected to the AC mains through Line Impedance Stability Network (L.I.S.N). This provided a 50ohm coupling impedance for the tested equipments. Both sides of AC line are investigated to find out the maximum conducted emission according to the EN61000-6-3 regulations during conducted emission measurement.

The bandwidth of the field strength meter (R&S Test Receiver ESCI 3) is set at 9KHz in 150KHz~30MHz and 200Hz in 9KHz~150KHz.

The frequency range from 150kHz to 30MHz is investigated

### 3.6. Measuring Results

N/A

## 4. RADIATED EMISSION MEASUREMENT

### 4.1. Block Diagram of Test

#### 4.1.1. Block diagram of test setup (In chamber)

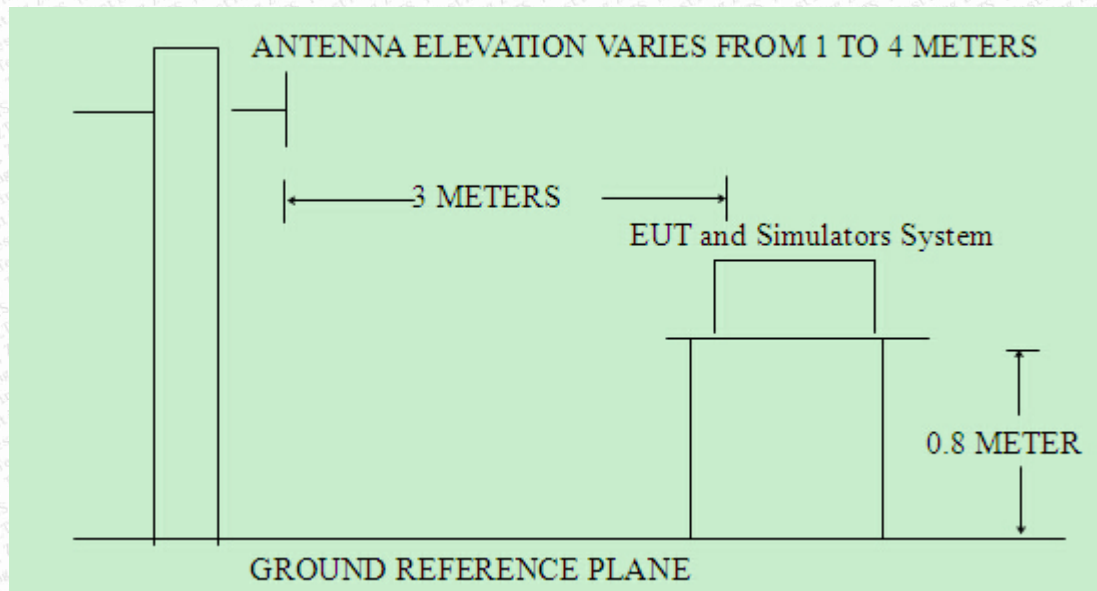

### 4.2. Measuring Standard

EN 61000-6-3: 2007+A1: 2011+AC: 2012

### 4.3. Radiated Emission Limits

All emanations from a class B device or system, including any network of conductors and apparatus connected thereto, shall not exceed the level of field strengths specified below:

FREQUENCY (MHz)	DISTANCE (Meters)	FIELD STRENGTHS LIMIT (dB $\mu$ V/m)
30 ~ 230	3	40
230 ~ 1000	3	47

Note: (1) The smaller limit shall apply at the combination point between two frequency bands.

(2) Distance refers to the distance in meters between the measuring instrument antenna and the closed point of any part of the EUT.

### 4.4. EUT Configuration on Test

The EN61000-6-3 regulations test method must be used to find the maximum emission during radiated emission measurement.

## 4.5. Operating Condition of EUT

4.5.1. Turn on the power.

4.5.2. After that, let the EUT work in test mode (Normal) and measure it.

## 4.6. Test Procedure

The EUT is placed on a turn table which is 0.8 meter high above the ground. The turn table can rotate 360 degrees to determine the position of the maximum emission level. The EUT is set 3 meters away from the receiving antenna which is mounted on a antenna tower. The antenna can be moved up and down from 1 to 4 meters to find out the maximum emission level. Bilog antenna (calibrated by Dipole Antenna) is used as a receiving antenna. Both horizontal and vertical polarization of the antenna are set on test.

The bandwidth of the Receiver (ESCI 3) is set at 120kHz.

The frequency range from 30MHz to 1000MHz is investigated.

## 4.7. Measuring Results

PASS

Please reference to the following pages

# Radiated Emission Test Data

EUT	: Tattoo Machine	Model	: TM-36
Operating Condition	: Normal Working	Test Site:	: Shielded Room
Power Supply	: 3-30V, 6A, 5-50W	Polarziation	: Horizontal
Operator:	: Mark	Tem	: 24°C Hum:55%
Start of Test:	: 2021-07-12		

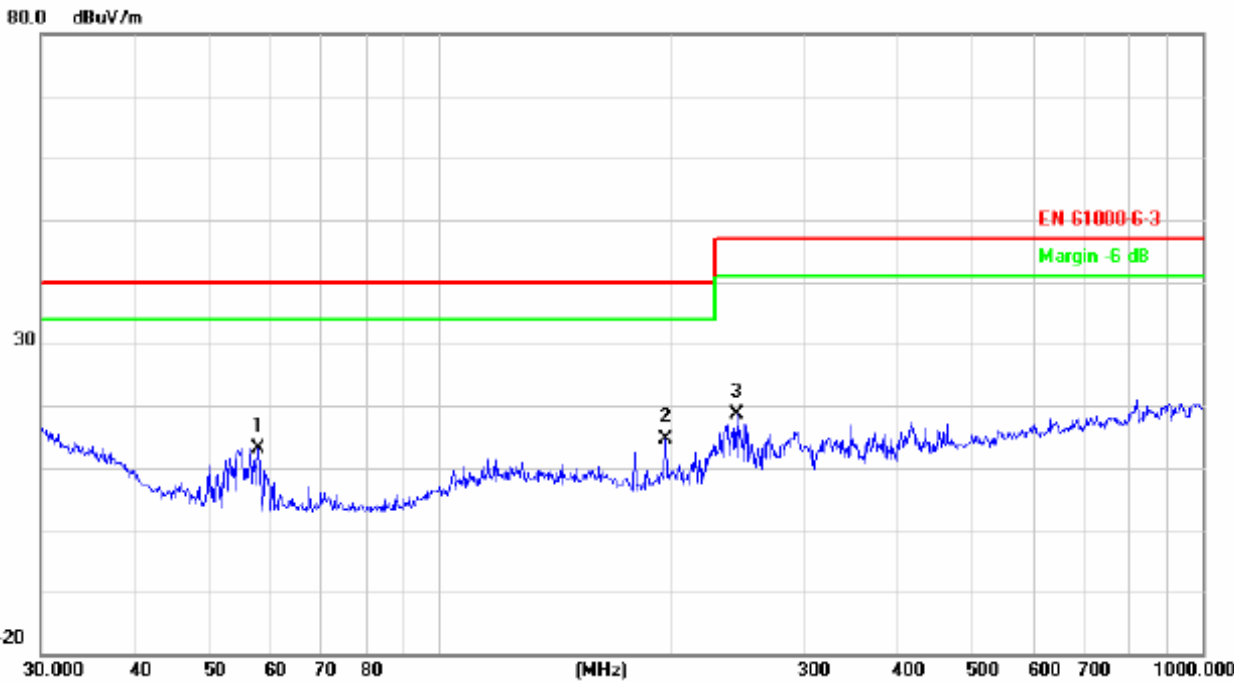

No.	Mk.	Freq. MHz	Reading Level dBuV	Correct Factor dB/m	Measure- ment dBuV/m	Limit dBuV/m	Over dB	Antenna Height cm	Table Degree degree	Comment
1		57.7961	33.57	-20.40	13.17	40.00	-26.83	peak		
2	*	197.8926	29.86	-15.20	14.66	40.00	-25.34	peak		
3		245.0900	34.40	-15.70	18.70	47.00	-28.30	peak		

## Radiated Emission Test Data

EUT	:	Tattoo Machine	Model	:	TM-36
Operating Condition	:	Normal Working	Test Site:	:	Shielded Room
Power Supply	:	3-30V, 6A, 5-50W	Polarization:	:	Vertical
Operator:	:	Mark	Tem	:	24°C Hum:55%
Start of Test:	:	2021-07-12			

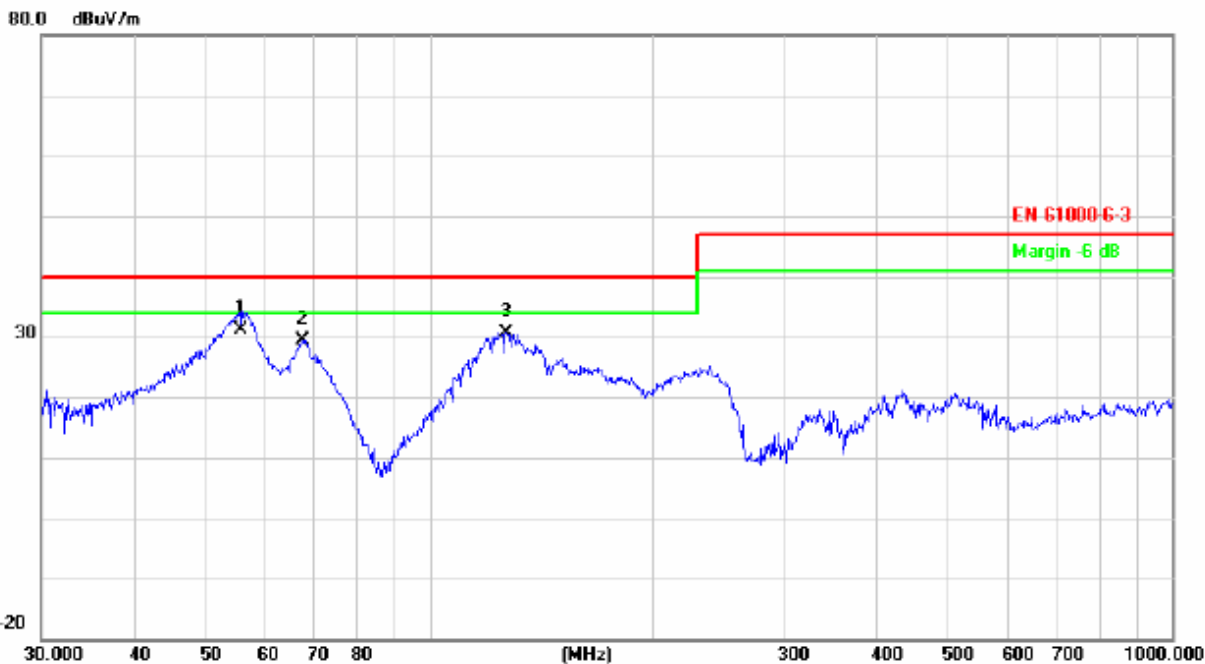

No.	Mk.	Freq.	Reading Level	Correct Factor	Measurement	Limit	Over	Antenna Height	Table Degree	
		MHz	dBuV	dB/m	dBuV/m	dBuV/m	dB	cm	degree	Comment
1	*	55.6094	51.75	-20.70	31.05	40.00	-8.95	QP		
2		67.4382	49.77	-20.35	29.42	40.00	-10.58	peak		
3		126.7723	44.76	-14.17	30.59	40.00	-9.41	peak		

## 5. HARMONIC CURRENT EMISSION MEASUREMENT

### 5.1. Block Diagram of Test Setup

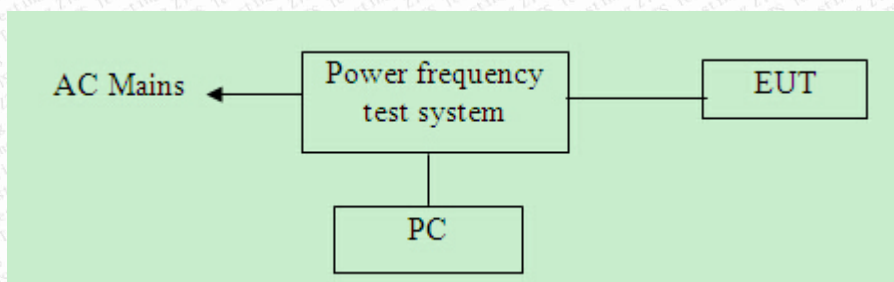

### 5.2. Measuring Standard

EN 61000-3-2: 2019

### 5.3. Operation Condition of EUT

Same as Section 3.4, except the test setup replaced as Section 5.1.

### 5.4. Measuring Results

N/A



## 6. VOLTAGE FLUCTUATION AND FLICKER MEASUREMENT

### 6.1. Block Diagram of Test Setup

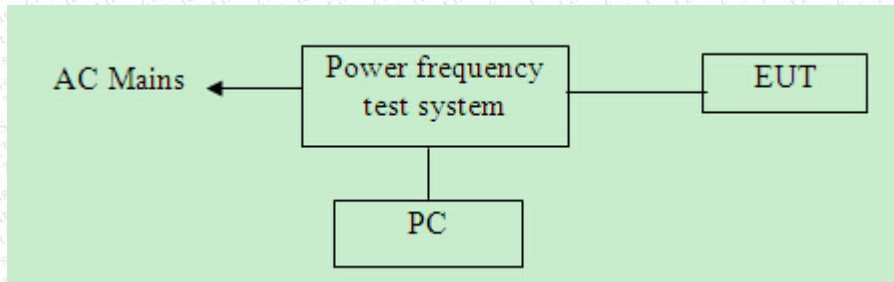

### 6.2. Measuring Standard

EN 61000-3-3: 2013+A1:2019

### 6.3. Operation Condition of EUT

6.3.1. Setup the EUT and simulators as shown in Section 6.1.

6.3.2. Turn on the power of all equipments.

6.3.3. Let the EUT work in test modes (Normal) and test it.

### 6.4. Measuring Results

N/A

## 7. ELECTROSTATIC DISCHARGE IMMUNITY TEST

### 7.1. Block Diagram of Test Setup

#### 7.1.1. Block Diagram of the EUT and the simulators

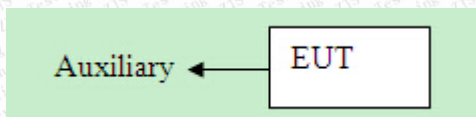

#### 7.1.2. Block diagram of ESD test setup

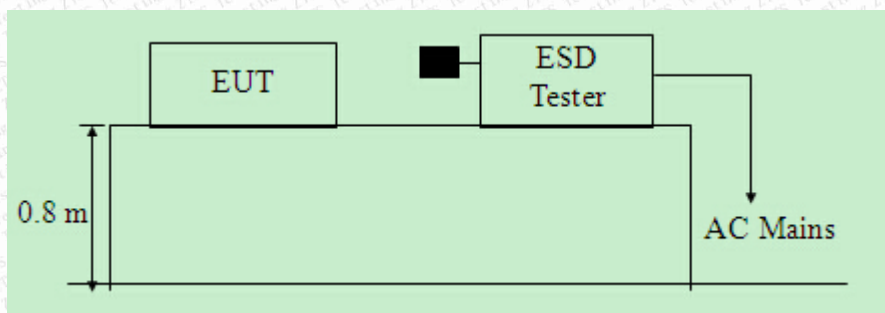

### 7.2. Test Standard

EN 61000-6-1: 2019(EN61000-4-2: 2009)

Severity Level: 3 / Air Discharge:  $\pm 8\text{KV}$  Level: 2 / Contact Discharge:  $\pm 4\text{KV}$

### 7.3. Severity Levels and Performance Criterion

#### 7.3.1. Severity level

Level	Test Voltage Contact Discharge (KV)	Test Voltage Air Discharge (KV)
1	$\pm 2$	$\pm 2$
2	$\pm 4$	$\pm 4$
3	$\pm 6$	$\pm 8$
4	$\pm 8$	$\pm 15$
X	Special	Special

#### 7.3.2. Performance criterion: B

### 7.4. EUT Configuration

The configuration of EUT is listed in Section 3.3.

## 7.5. Operating Condition of EUT

Same as conducted emission measurement, which is listed in Section 3.4. Except the test set up replaced by Section 7.1.

## 7.6. Test Procedure

### 7.6.1. Air Discharge:

This test is done on a non-conductive surface. The round discharge tip of the discharge electrode shall be approached as fast as possible to touch the EUT. After each discharge, the discharge electrode shall be removed from the EUT. The generator is then re-triggered for a new single discharge and repeated 10 times for each pre-selected test point. This procedure shall be repeated until all the air discharge completed.

### 7.6.2. Contact Discharge:

All the procedure shall be same as Section 7.6.1. except that the tip of the discharge electrode shall touch the EUT before the discharge switch is operated.

### 7.6.3. Indirect discharge for horizontal coupling plane

At least 10 single discharges (in the most sensitive polarity) shall be applied at the front edge of each HCP opposite the center point of each unit (if applicable) of the EUT and 0.1m from the front of the EUT. The long axis of the discharge electrode shall be in the plane of the HCP and perpendicular to its front edge during the discharge.

### 7.6.4. Indirect discharge for vertical coupling plane

At least 10 single discharge (in the most sensitive polarity) shall be applied to the center of one vertical edge of the coupling plane. The coupling plane, of dimensions 0.5m X 0.5m, is placed parallel to, and positioned at a distance of 0.1m from the EUT. Discharges shall be applied to the coupling plane, with this plane in sufficient different positions that the four faces of the EUT are completely illuminated.

## 7.7. Test Results

PASS

Please refer to the following page



# Electrostatic Discharge Test Result

Applicant	: Yiwu wenmei import & export Co., Ltd	Test Date	: 2021-07-12
EUT	: Tattoo Machine	Temperature	: 22°C
M/N	: TM-36	Humidity	: 50%
Power Supply	: 3-30V, 6A, 5-50W	Test Mode	: Full load
Air discharge	: ± 2.0KV, ± 4.0KV, ± 6.0KV, ± 8.0KV	Criterion	: B
Contact discharge	: ± 2.0KV, ± 4.0KV	Test Engineer	: Mark

Air Discharge						
Test Points	Test Levels			Results		Performance Criterion
	± 2kV	± 4kV	± 8kV	Passed	Fail	
Front	<input checked="" type="checkbox"/>	<input checked="" type="checkbox"/>	<input checked="" type="checkbox"/>	<input checked="" type="checkbox"/>	<input type="checkbox"/>	<input type="checkbox"/> A <input checked="" type="checkbox"/> B
Back	<input checked="" type="checkbox"/>	<input checked="" type="checkbox"/>	<input checked="" type="checkbox"/>	<input checked="" type="checkbox"/>	<input type="checkbox"/>	<input type="checkbox"/> A <input checked="" type="checkbox"/> B
Left	<input checked="" type="checkbox"/>	<input checked="" type="checkbox"/>	<input checked="" type="checkbox"/>	<input checked="" type="checkbox"/>	<input type="checkbox"/>	<input type="checkbox"/> A <input checked="" type="checkbox"/> B
Right	<input checked="" type="checkbox"/>	<input checked="" type="checkbox"/>	<input checked="" type="checkbox"/>	<input checked="" type="checkbox"/>	<input type="checkbox"/>	<input type="checkbox"/> A <input checked="" type="checkbox"/> B
Top	<input checked="" type="checkbox"/>	<input checked="" type="checkbox"/>	<input checked="" type="checkbox"/>	<input checked="" type="checkbox"/>	<input type="checkbox"/>	<input type="checkbox"/> A <input checked="" type="checkbox"/> B
Bottom	<input checked="" type="checkbox"/>	<input checked="" type="checkbox"/>	<input checked="" type="checkbox"/>	<input checked="" type="checkbox"/>	<input type="checkbox"/>	<input type="checkbox"/> A <input checked="" type="checkbox"/> B

Contact Discharge						
Test Points	Test Levels			Results		Performance Criterion
	± 2 kV	±4 kV	± 6kV	Passed	Fail	
Front	<input checked="" type="checkbox"/>	<input checked="" type="checkbox"/>	<input type="checkbox"/>	<input checked="" type="checkbox"/>	<input type="checkbox"/>	<input type="checkbox"/> A <input checked="" type="checkbox"/> B
Back	<input checked="" type="checkbox"/>	<input checked="" type="checkbox"/>	<input type="checkbox"/>	<input checked="" type="checkbox"/>	<input type="checkbox"/>	<input type="checkbox"/> A <input checked="" type="checkbox"/> B
Left	<input checked="" type="checkbox"/>	<input checked="" type="checkbox"/>	<input type="checkbox"/>	<input checked="" type="checkbox"/>	<input type="checkbox"/>	<input type="checkbox"/> A <input checked="" type="checkbox"/> B
Right	<input checked="" type="checkbox"/>	<input checked="" type="checkbox"/>	<input type="checkbox"/>	<input checked="" type="checkbox"/>	<input type="checkbox"/>	<input type="checkbox"/> A <input checked="" type="checkbox"/> B
Top	<input checked="" type="checkbox"/>	<input checked="" type="checkbox"/>	<input type="checkbox"/>	<input checked="" type="checkbox"/>	<input type="checkbox"/>	<input type="checkbox"/> A <input checked="" type="checkbox"/> B
Bottom	<input checked="" type="checkbox"/>	<input checked="" type="checkbox"/>	<input type="checkbox"/>	<input checked="" type="checkbox"/>	<input type="checkbox"/>	<input type="checkbox"/> A <input checked="" type="checkbox"/> B

Discharge To Horizontal Coupling Plane						
Side of EUT	Test Levels			Results		Performance Criterion
	± 2 kV	± 4 kV	± 6 kV	Passed	Fail	
Front	<input checked="" type="checkbox"/>	<input checked="" type="checkbox"/>	<input type="checkbox"/>	<input checked="" type="checkbox"/>	<input type="checkbox"/>	<input type="checkbox"/> A <input checked="" type="checkbox"/> B
Back	<input checked="" type="checkbox"/>	<input checked="" type="checkbox"/>	<input type="checkbox"/>	<input checked="" type="checkbox"/>	<input type="checkbox"/>	<input type="checkbox"/> A <input checked="" type="checkbox"/> B
Left	<input checked="" type="checkbox"/>	<input checked="" type="checkbox"/>	<input type="checkbox"/>	<input checked="" type="checkbox"/>	<input type="checkbox"/>	<input type="checkbox"/> A <input checked="" type="checkbox"/> B
Right	<input checked="" type="checkbox"/>	<input checked="" type="checkbox"/>	<input type="checkbox"/>	<input checked="" type="checkbox"/>	<input type="checkbox"/>	<input type="checkbox"/> A <input checked="" type="checkbox"/> B

Discharge To Vertical Coupling Plane						
Side of EUT	Test Levels			Results		Performance Criterion
	± 2 kV	± 4 kV	± 6 kV	Passed	Fail	
Front	<input checked="" type="checkbox"/>	<input checked="" type="checkbox"/>	<input type="checkbox"/>	<input checked="" type="checkbox"/>	<input type="checkbox"/>	<input type="checkbox"/> A <input checked="" type="checkbox"/> B
Back	<input checked="" type="checkbox"/>	<input checked="" type="checkbox"/>	<input type="checkbox"/>	<input checked="" type="checkbox"/>	<input type="checkbox"/>	<input type="checkbox"/> A <input checked="" type="checkbox"/> B
Left	<input checked="" type="checkbox"/>	<input checked="" type="checkbox"/>	<input type="checkbox"/>	<input checked="" type="checkbox"/>	<input type="checkbox"/>	<input type="checkbox"/> A <input checked="" type="checkbox"/> B
Right	<input checked="" type="checkbox"/>	<input checked="" type="checkbox"/>	<input type="checkbox"/>	<input checked="" type="checkbox"/>	<input type="checkbox"/>	<input type="checkbox"/> A <input checked="" type="checkbox"/> B

## 8. RF FIELD STRENGTH SUSCEPTIBILITY TEST

### 8.1. Block Diagram of Test

#### 8.1.1. Block diagram of connection between the EUT and Load

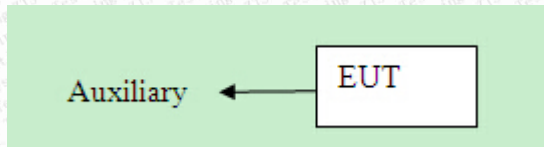

#### 8.1.2. Block diagram of RS test setup

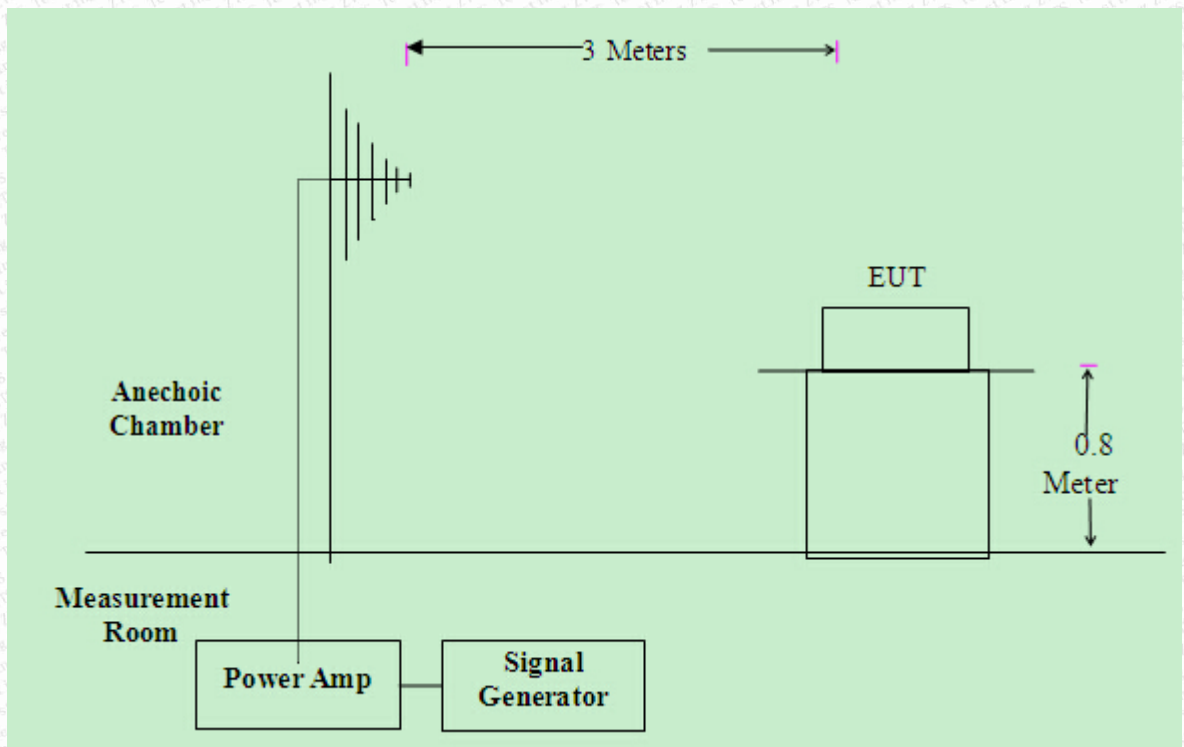

### 8.2. Test Standard

EN 61000-6-1: 2019(EN61000-4-3:2006 +A1:2008+A2:2010 (Severity Level: 2, 30V / m)

### 8.3. Severity Levels and Performance Criterion

#### 8.1.3 .Severity Levels

Level	Field Strength V/m
1	1
2	3
3	10
X	Special

#### 8.1.4 .Performance Criterion : A

### 8.4. EUT Configuration on Test

The configuration of the EUT is same as Section 3.3.

### 8.5. Operating Condition of EUT

Same as radiated emission measurement which is listed in Section 3.4, except the test setup replaced as Section 8.1.

### 8.6. Test Procedure

The EUT are placed on a table which is 0.8 meter high above the ground. The

EUT is set 3 meters away from the transmitting antenna which is mounted on an antenna tower. Both horizontal and vertical polarization of the antenna are set on test. Each of the four sides of the EUT must be faced this transmitting antenna and measured individually.

In order to judge the EUT performance, a CCD camera is used to monitor its screen.

All the scanning conditions are as following:

Condition of Test	Remark
-----	-----
1. Fielded Strength	30V/m (Severity Level 2)
2. Radiated Signal	Modulated
3. Scanning Frequency	80-1000MHz
4. Sweep time of radiated	0.0015 Decade/s
5. Dwell Time	1 Sec.

### 8.7. Test Results

PASS

Please refer to the following page.



## RF Field Strength Susceptibility Test Results

Applicant	: Yiwu wenmei import & export Co., Ltd	Test Date	: 2021-07-12					
EUT	: Tattoo Machine	Temperature	: 22°C					
M/N	: TM-36	Humidity	: 50 %					
Field Strength	: 3 V/m	Criterion	: A					
Power Supply	: 3-30V, 6A, 5-50W	Test Mode	: Normal					
Test Engineer	: Mark	Frequency Range	: 80 MHz to 1000 MHz					
<table style="width: 100%; border: none;"> <tr> <td style="width: 25%; border: none;">Modulation:</td> <td style="width: 30%; border: none;"><input type="checkbox"/> None</td> <td style="width: 25%; border: none;"><input type="checkbox"/> Pulse</td> <td style="width: 20%; border: none;"><input checked="" type="checkbox"/> AM 1KHz 80%</td> </tr> </table>					Modulation:	<input type="checkbox"/> None	<input type="checkbox"/> Pulse	<input checked="" type="checkbox"/> AM 1KHz 80%
Modulation:	<input type="checkbox"/> None	<input type="checkbox"/> Pulse	<input checked="" type="checkbox"/> AM 1KHz 80%					
		Frequency Rang 1: 80~ 1000MHz	Frequency Rang 2: 1400~ 2000MHz					
Steps	1	/	%	#	/	%		
	Horizontal		Vertical	Horizontal		Vertical		
Front	PASS		PASS	PASS		PASS		
Right	PASS		PASS	PASS		PASS		
Rear	PASS		PASS	PASS		PASS		
Left	PASS		PASS	PASS		PASS		
<b>Test Equipment :</b> 1. Signal Generator : 2031 (MARCONI) 2. Power Amplifier : 500A100 & 100W/1000M1 (A&R) 3. Power Antenna : 3108 (EMCO) & AT1080 (A&R) 4. Field Monitor : FM2000 (A&R)								
<b>Note:</b>								

## 9. ELECTRICAL FAST TRANSIENT/BURST IMMUNITY TEST

### 9.1. Block Diagram of Test Setup

#### 9.1.1. Block Diagram of the EUT

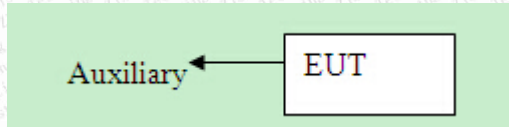

#### 9.1.2. EUT Test Setup

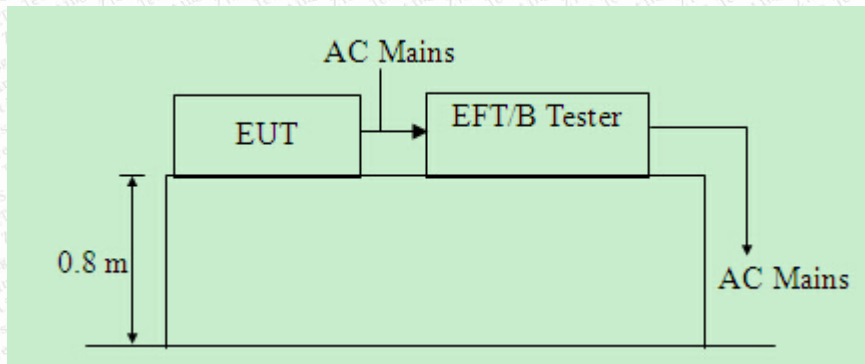

### 9.2. Test Standard

EN 61000-6-1: 2019(EN61000-4-4:2004+A1:2010, Severity Level, Level 2: 1KV)

### 9.3. Severity Levels and Performance Criterion

#### 9.3.1. Severity level

Open Circuit Output Test Voltage $\pm 10\%$		
Level	On Power Supply Lines	On I/O (Input/Output) Signal data and control lines
1	0.5 KV	0.25 KV
2	1 KV	0.5 KV
3	2 KV	1 KV
4	4 KV	2 KV
X	Special	Special

#### 9.3.2. Performance criterion : **B**

### 9.4. EUT Configuration

The configuration of EUT is listed in Section 3.3.



## 9.5. Operating Condition of EUT

- 9.5.1. Setup the EUT as shown in Section 9.1.
- 9.5.2. Turn on the power of all equipments.
- 9.5.3. Let the EUT work in test mode (Normal) and measure it.

## 9.6. Test Procedure

The EUT is put on the table which is 0.8 meter high above the ground. This reference ground plane shall project beyond the EUT by at least 0.1m on all sides and the minimum distance between EUT and all other conductive structure, except the ground plane beneath the EUT, shall be more than 0.5m.

### 9.6.1. For input and output AC power ports:

The EUT is connected to the power mains by using a coupling device which couples the EFT interference signal to AC power lines. Both polarities of the test voltage should be applied during compliance test and the duration of the test is 2 mins.

### 9.6.2. For signal lines and control lines ports:

No I/O ports. It's unnecessary to test.

### 9.6.3. For DC output line ports:

It's unnecessary to test.

## 9.7. Test Result

N/A

## 10.NITY TEST

### 10.1.Block Diagram of Test Setup

#### 10.1.1.Block Diagram of the EUT

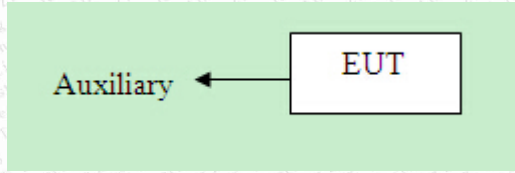

#### 10.1.2.Surge Test Setup

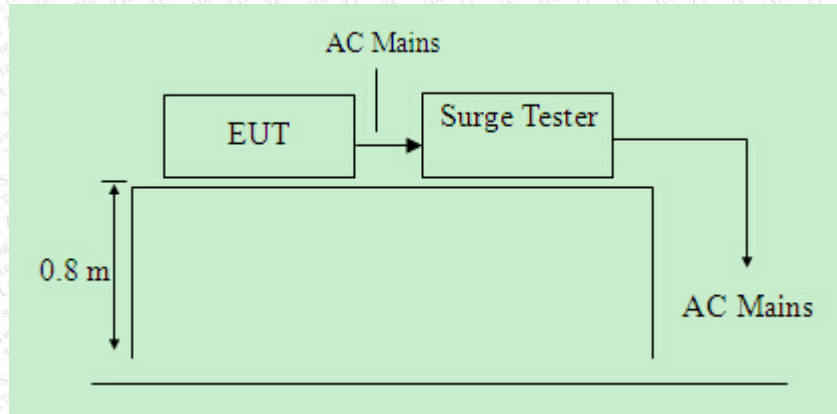

### 10.2.Test Standard

EN 61000-6-1: 2019(EN61000-4-5: 2006)

Severity Level: Line to Line: Level 2, 1.0KV

### 10.3.Severity Levels and Performance Criterion

#### 10.3.1.Severity level

Severity Level	Open-Circuit Test Voltage	
	KV	
1	0.5	
2	1.0	
3	2.0	
4	4.0	
*	Special	

#### 10.3.2.Performance criterion : B

### 10.4.EUT Configuration

The configuration of EUT is listed in Section 3.3.

## 10.5. Operating Condition of EUT

- 10.5.1. Setup the EUT as shown in Section 10.1.
- 10.5.2. Turn on the power of all equipments.
- 10.5.3. Let the EUT work in test mode (Normal) and measure it.

## 10.6. Test Procedure

- 10.6.1. Set up the EUT and test generator as shown on Section 10.1.2.
- 10.6.2. For line to line coupling mode, provide a 1.0 KV 1.2/50us voltage surge (at open-circuit condition) and 8/20us current surge to EUT selected points.
- 10.6.3. At least 5 positive and 5 negative (polarity) tests with a maximum 1/min repetition rate are conducted during test.
- 10.6.4. Different phase angles are done individually.
- 10.6.5. Record the EUT operating situation during compliance test and decide the EUT immunity criterion for above each test.

## 10.7. Test Result

N/A

# 11. INJECTED CURRENTS SUSCEPTIBILITY TEST

## 11.1. Block Diagram of Test Setup

### 11.1.1. Block Diagram of the EUT

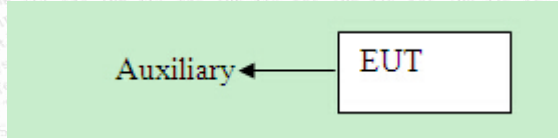

### 11.1.2. Block Diagram of Test Setup

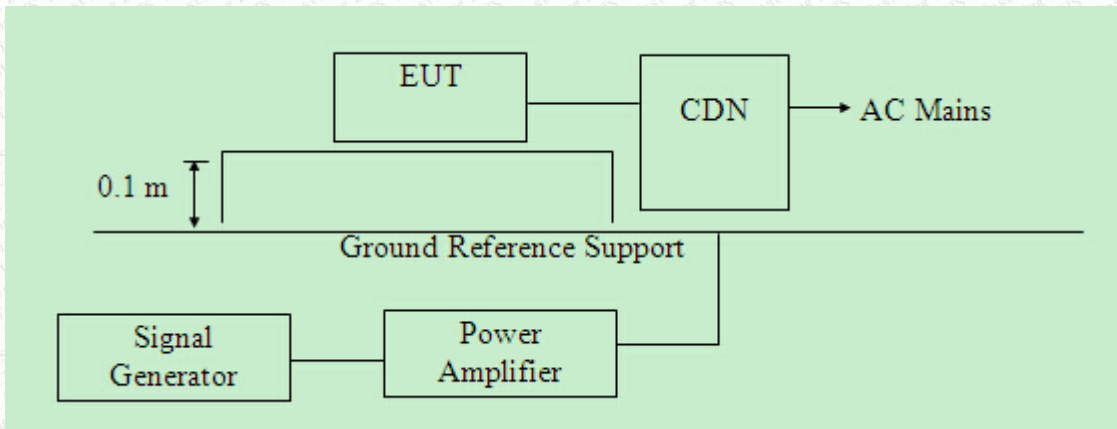

## 11.2. Test Standard

EN 61000-6-1: 2019 (EN61000-4-6: 2009, Severity Level: Level 2, 30V (rms), (0.15MHz ~ 80MHz)

## 11.3. Severity Levels and Performance Criterion

### 11.3.1. Severity level

Level	Field Strength V
1	1
2	3
3	10
X	Special

### 11.3.2. Performance criterion: A

## 11.4. EUT Configuration

The configuration of EUT is listed in Section 3.3.

## 11.5. Operating Condition of EUT

- 11.5.1. Setup the EUT as shown in Section 11.1.
- 11.5.2. Turn on the power of all equipments.
- 11.5.3. Let the EUT work in test mode (Normal) and measure it.

## 11.6. Test Procedure

- 11.6.1. Set up the EUT, CDN and test generators as shown on Section 11.1.2.
- 11.6.2. Let the EUT work in test mode and measure it.
- 11.6.3. The EUT are placed on an insulating support 0.1m high above a ground reference plane. CDN (coupling and decoupling device) is placed on the ground plane about 0.3m from EUT. Cables between CDN and EUT are as short as possible, and their height above the ground reference plane shall be between 30 and 50 mm (where possible).
- 11.6.4. The disturbance signal described below is injected to EUT through CDN.
- 11.6.5. The EUT operates within its operational mode(s) under intended climatic conditions after power on.
- 11.6.6. The frequency range is swept from 150KHz to 80MHz using 30V signal level, and with the disturbance signal 80% amplitude modulated with a 1KHz sine wave.
- 11.6.7. The rate of sweep shall not exceed  $1.5 \times 10^{-3}$  decades/s. Where the frequency is swept incrementally, the step size shall not exceed 1% of the start and thereafter 1% of the preceding frequency value.
- 11.6.8. Recording the EUT operating situation during compliance test and decide the EUT immunity criterion.

## 11.7. Test Results

N/A

## 12.MAGNETIC FIELD SUSCEPTIBILITY TEST

### 12.1.Block Diagram of Test

#### 12.1.1.Block diagram of test setup

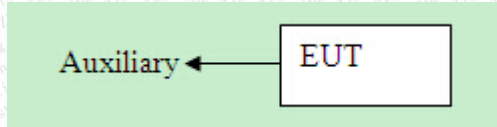

#### 12.1.2.Magnetic field test setup

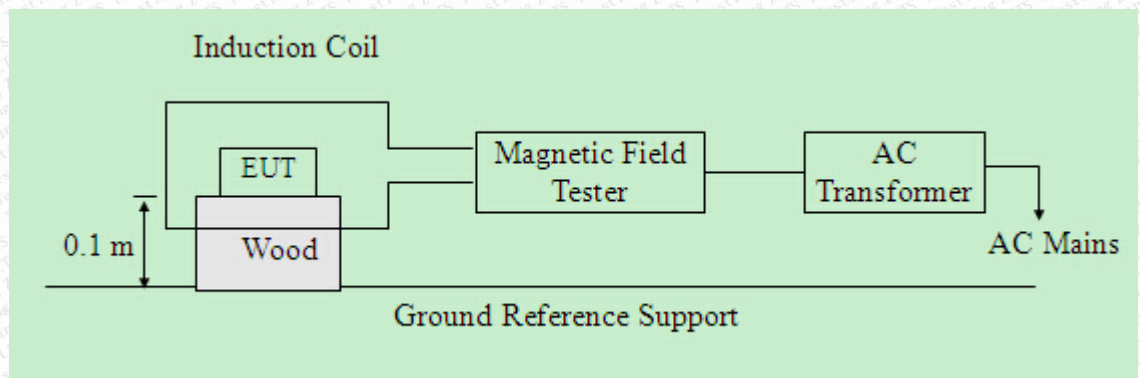

### 12.2.Test Standard

EN 61000-6-1: 2019 (EN61000-4-8: 2010, Severity Level: Level 1, 40A / m)

### 12.3.Severity Levels and Performance Criterion

#### 12.3.1.Severity Levels

Level	Field Strength A/m
1	1
2	3
3	10
4	30
5	100
X	Special

#### 12.3.2.Performance Criterion : A

### 12.4.EUT Configuration on Test

The configuration of the EUT is same as Section 3.3.

## 12.5. Test Procedure

The EUT is placed in the middle of a induction coil (1\*1m), under which is a 1\*1\*0.1m (high) table, this small table is also placed on a larger table, 0.8 m above the ground. Both horizontal and vertical polarization of the induction coil are set on test, so that each side of the EUT is affected by the magnetic field. Also can reach the same aim by change the position of the EUT.

## 12.6. Test Results

N/A

# 13.VOLTAGE DIPS AND INTERRUPTIONS TEST

## 13.1.Block Diagram of Test Setup

### 13.1.1.Block Diagram of the EUT

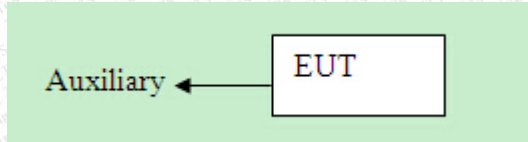

### 13.1.2.Dips Test Setup

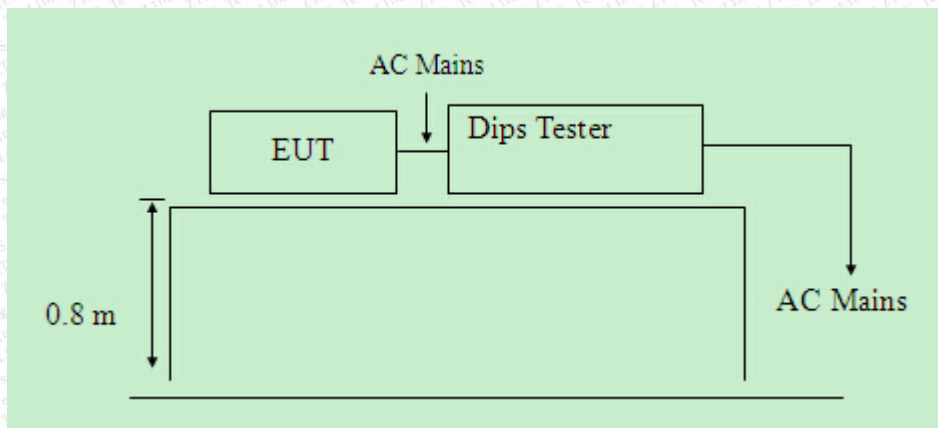

## 13.2.Test Standard

EN 61000-6-1: 2019(EN61000-4-11: 2004)

## 13.3.Severity Levels and Performance Criterion

### 13.3.1.Severity level

Test Level %UT	Voltage dip and short interruptions %UT	Duration (in period)
0	100	0.5
40	60	1
		5
70	30	10
		25
		50
		*

### 13.3.2.Performance criterion : **B&C**

## 13.4.EUT Configuration

The configuration of EUT is listed in Section 3.3.



### 13.5. Operating Condition of EUT

13.5.1 Setup the EUT as shown in Section 13.1.

13.5.2 Turn on the power of all equipments.

13.5.3 Let the EUT work in test mode (Normal) and measure it.

### 13.6. Test Procedure

13.6.1. Set up the EUT and test generator as shown on Section 13.1.2.

13.6.2. The interruptions is introduced at selected phase angles with specified duration.

13.6.3. Record any degradation of performance.

### 13.7. Test Result

N/A



## APPENDIX I (Photos of EUT)

**FIGURE  
GENERAL APPEARANCE OF EUT**



Photo 1



Photo 2

\*\*\*\*\*THE END OF REPORT\*\*\*\*\*