

Competition Electronics, Inc

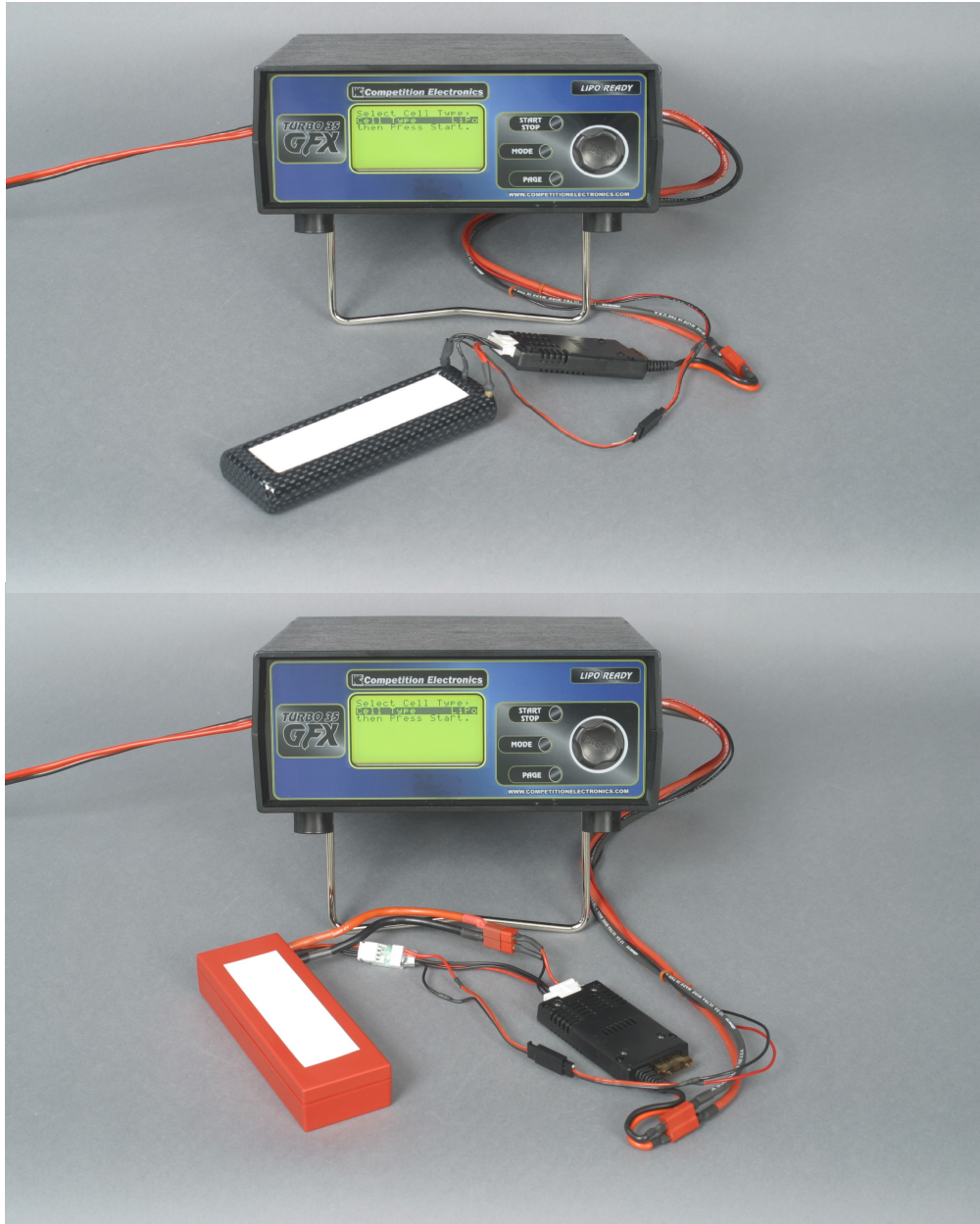

Turbo35-GFX LiPo User's Manual Addendum

Introduction

This enhancement makes it possible to charge 1,2 and 3 cell LiPo battery packs with the T35-GFX. Now you can have the accuracy and reliability of the T35-GFX for LiPo charging, as well as NimH/NiCd charging.

Safety Considerations

WARNING: Please read before using your Turbo35-GFX LiPo charger/discharger:

IMPORTANT SAFETY INSTRUCTIONS AND WARNINGS

- You must read these safety instructions and warnings before using the Turbo35-GFX LiPo battery charger.
- **Lithium Polymer batteries are volatile.** Failure to read and follow the below instructions may result in fire, personal injury and damage to property if charged or used improperly.
- Competition Electronics, Inc, its distributors or retailers assume no liability for failures to comply with these warnings and safety guidelines.

General Guidelines and Warnings

1. **Use only the LiPo mode, never the NimH/NiCd mode, to charge and discharge LiPo batteries.** Failure to do so may cause a fire, which may result in personal injury and property damage. Likewise, do not attempt to work with NimH/NiCd packs in LiPo mode.
2. **Always use the sense leads.** LiPo operations require precise voltage sensing; damage to LiPo packs may occur if you fail to use the sense leads.
3. **Never charge batteries unattended.** When charging LiPo batteries you should always remain in constant observation to monitor the charging process and react to potential problems that may occur.
4. **If at any time you witness a battery starting to balloon or swell up, discontinue the charging process immediately, disconnect the battery and observe it in a safe place for approximately 15 minutes.** This may cause the battery to leak, and the reaction with air may cause the chemicals to ignite, resulting in fire.
5. Since delayed chemical reaction can occur, it is best to observe the battery as a safety precaution. Battery observation should occur in a safe area outside of any building or vehicle and away from any combustible material.
6. **Wire lead shorts can cause fire!** If you accidentally short the wires, the battery **must** be placed in a safe area for observation for approximately 15 minutes. Additionally, if a short occurs and contact is made with metal (such as rings on your hand), severe injuries may occur due to the LiPo pack's ability to supply massive amperage.
7. A battery can still ignite even after 10 minutes.
8. In the event of a crash, avoid any charging or discharging of a LiPo battery until you have placed it in a safe open area away from any combustible material and observed it for approximately 15 minutes.
9. Never store, charge or discharge battery pack inside your car in extreme temperatures, since extreme temperature could ignite fire.
10. Monitor the condition of your LiPo packs and discontinue use when performance degrades or changes significantly.
11. OBSERVE PROPER POLARITIES BETWEEN CHARGER AND PACK WITHOUT FAIL.

Charging/Discharging Process

1. Never charge/discharge batteries unattended.
2. **Charge or Discharge in an isolated area, away from other flammable materials.**
3. Let battery cool down to ambient temperature before charging.
4. **Do not charge/discharge battery packs in series.** Charge each battery pack individually. Failure to do so may result in incorrect battery recognition and charging functions. Overcharging may occur and fire may be the result.
5. When selecting the cell count or voltage for charging purposes, select the cell count and voltage as it appears on the battery label. As a safety precaution, confirm the information printed on the battery is correct.
6. Selecting a cell count other than the one printed on the battery (always confirm label is correct), can cause fire.
7. **You must check the pack voltage before charging/discharging.** It is not advisable to attempt to charge any pack if open voltage per cell is less than 3.3v. If you insist and the per cell voltage is greater than 2.3 volts, the Turbo35-GFX LiPo will charge the pack at a reduced current for 2 minutes in an attempt to reach at least 3V per cell. However, chances are the pack is damaged and will need replacement.
8. CEI recommends charging at **1C rate or less (mAHr capacity of the battery/1000 in units of amperes), unless the manufacturer specifically recommends otherwise.**
9. **Do not discharge battery to a level below 3V per cell under load.** Deep discharge below 3V per cell can deteriorate battery performance.

Caring for Battery

1. Use caution to avoid puncture of the cell. Puncture of cells may cause a fire.

Operating Temperature

Typical Charge temperatures:	32 to 113 degrees F
Typical Discharge temperatures:	32 to 140 degrees F

1. Consult the specific manufacturer's data sheet for temperature data before charging or discharging a LiPo battery.
2. Let battery cool down to an ambient temperature before charging.
3. During discharge and handling of batteries, do not exceed 160 degrees F.

Significant Changes in the Turbo-GFX LiPo Charger

In order to add the LiPo capability, the scrolling help message system in the Turbo35-GFX LiPo was eliminated.

In addition, the number of storable setups for the NimH/NiCd function has been reduced to 5, in order to free up 5 setups for the LiPo mode.

However, no other functionality was removed.

Navigating the LiPo screens is no different than navigating the original NimH/NiCd screens, with this exception: not all the calculated and measured data produced with NimH/NiCd packs makes sense with LiPo packs, so certain data has been eliminated in the LiPo mode.

Connecting the Turbo35-GFX Lipo to a LiPo Pack

The hazards to both the battery and operator associated with shorting out or reversing polarity to LiPo packs make it essential that care is taken with connections between the Turbo35-GFX LiPo and the pack. Smaller packs, such as transmitter packs or packs used for airplanes often come with a pin and socket type connector, or a Dean's connector already assembled to the pack. If the connector ampacity is sufficient for the discharge rate, it is suggested that you obtain a mating connector and affix it to the GFX contacts in such a way that no short or polarity reversal is possible.

Larger packs such as those intended for R/C cars, often have low resistance, gold-plated barrel-type connectors. In this case, CEI recommends obtaining the proper mating connectors and connecting them to the Turbo35-GFX LiPo output leads in such a way that shorting of the pack is not possible. In this case, it is recommended that similar proper mating connectors be directly attached to the Turbo35-GFX LiPo output leads.

For convenience, you can use suitable connectors, such as Dean's connectors, on the sense and power leads. Then, make plug-in harnesses for different pack types; terminate the NimH/NiCd harness with the usual large and small alligator clips. Terminate the LiPo harness with a pair of high quality barrel connectors specifically designed to mate with the LiPo pack.

CEI DOES NOT recommend using alligator clips or any dissimilar connector to directly connect to the LiPo pack's recessed terminals. In addition, avoid lots of floppy alligator-clipped connections with LiPo packs. Make the connections as simple as possible, and as short as practical.

Sense Leads

ALWAYS USE THE SENSE LEADS WITH LIPO PACKS.

If your pack has high current barrel connectors such as those mentioned above, then it is best if you mate the sense leads with their respective polarity power leads directly at the barrel connector. Crimp or solder both power and sense lead directly into the mating barrel connector. Soldering is the most foolproof method; however, soldering is not always necessary, especially where the sense leads are concerned. In any case, always try to connect the sense leads as close to the actual cell contacts as possible, and try to assure that current through the sense leads does not travel through any more connections than is necessary.

CAUTION: Inadvertent shorting of battery leads may cause fire or explosion!

These battery packs are capable of huge amperage and so extreme caution should always be used when creating and using wiring networks to charge and discharge these packs. It is recommended that you work on one wire at a time and place insulating devices such as tape over other exposed connections to avoid the possibility of shorts.

Making the Proper Connections when Charging or Discharging a LiPo Pack

There are legitimate occasions when you may choose to forgo using a balancer during charging, for

example, in order to charge at a higher rate.

In addition, you may be running a high current discharge on your LiPo pack. It is important to realize that improper use or connection of the sense leads during charge or discharge can result in damage to the pack or overcharge, leading to the unpleasant surprise of disqualification when the pack is inspected by technical personnel at a race. To avoid these unpleasant outcomes, you need to apply the principals outlined above.

Here is the best way to connect the sense leads when charging or discharging a LiPo pack configured with the separate balance connector.

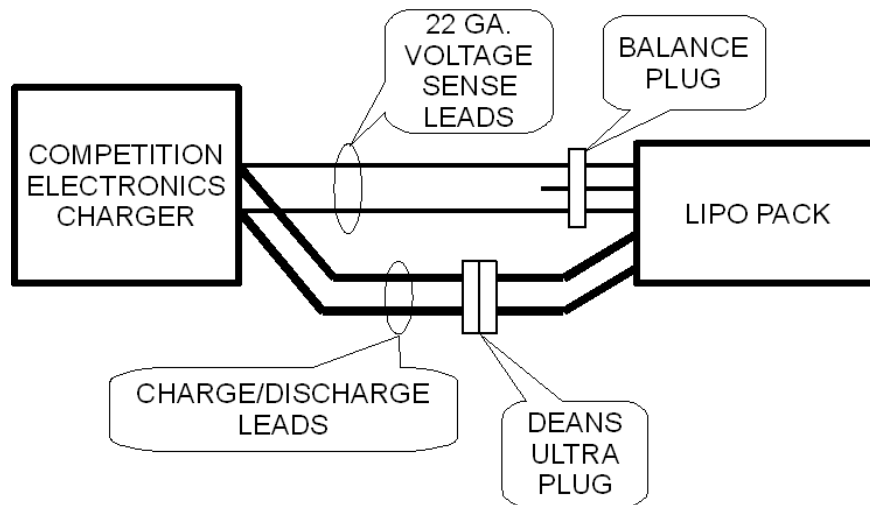

In this case, the sense leads are connected to the balance plug; you will want to connect them to the pins which correspond to the “outside” of the pack, that is, those pins across which the entire pack voltage appears. This gives the sense leads a direct and exclusive connection to the pack for the best voltage reading accuracy during charge and discharge. In almost every case this will be the two pins located at the outsides of the connector; you can check by measuring the voltage across the pins to see if it is the same as the voltage across the large current carrying leads.

Observe proper polarities.

In the case of a LiPo pack with bullet connectors, connect the sense leads directly at the main bullet connectors by stripping back a small bit of insulation at the bullet connector, then clipping the sense leads at these locations.

Connections for Single Cell LiPo Packs

Single cell LiPo packs by definition contain no balance connector; therefore all connections to the pack must be made through the main power leads. In order to obtain maximum accuracy, you must make effective use of the sense leads of the T35-GFX LiPo charger. CEI recommends creating a special harness assembly for single cell packs, as shown below.

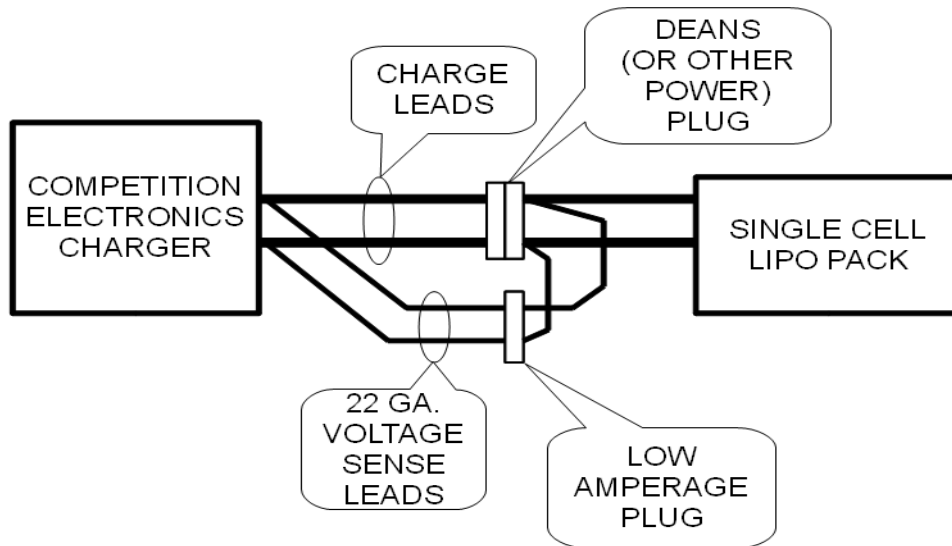

Note that the sense leads are connected through a dedicated connector to the *other side* of the power connector. This way, error due to any significant source of voltage drop across the power connector is eliminated.

It is strongly recommended that you use *two different types of connectors* to avoid accidentally plugging them together the wrong way. A servo connector or something similar would be a good choice for the sense lead connections.

Again, in the case of a single cell LiPo pack with bullet connectors, connect the sense leads directly at the main bullet connectors by stripping back a small bit of insulation at the bullet connector, then clipping the sense leads at these locations.

Important: Using an External Balancer with the T35-GFX LiPo

The first thing to be aware of when using an external balancer with the T35-GFX LiPo is that **it is to be connected only during charging**. You must completely disconnect the balancer during discharge, cycle, or motor operations.

As already mentioned, the Turbo35-GFX LiPo incorporates special voltage sense leads so that it can measure voltage with greater precision under all conditions. However, this does make achieving the proper connections more complex, especially when charging LiPo packs using external balancing devices. Because accurate voltage control is a must when working with LiPo packs, proper connection of the sense leads is critical.

To reiterate: **you must use the sense leads when working with LiPo packs!**

In order to get good results when working with LiPo packs, it is important to understand these two principles:

- Connection of the sense leads should always be made as close as possible to the LiPo pack terminals, both electrically and physically.
- The more current there is flowing through a connection or wire, the more voltage drop will occur across that connection or wire, and the more error there will be in the voltage reading if that connection or wire is between the pack and the sense leads.

Now, with these two principles in mind, let's look at a couple of diagrams that show a hypothetical balancer used with the T35-GFX to charge-balance 2C LiPo packs.

The first, below, is a diagram showing the connections for a LiPo pack with bullet connectors. Note that this pack has two high current bullet connectors which serve for both balance and charge functions, and a separate, smaller bullet connector in the center which is intended for balancing. (That does not mean that it could not be used for charging, but current limitations of the smaller connector must be observed.)

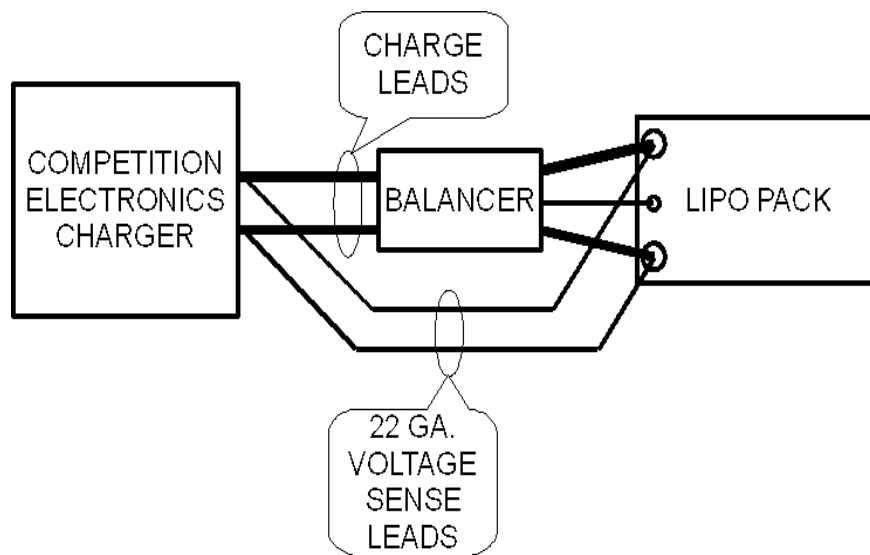

Note the following:

- The GFX's heavy current-carrying charge leads connect directly to the input of the balancer.
- The balancer's output leads, equipped with the proper harness, are connected to the LiPo pack per the balancer manufacturer's instructions.
- The GFX's sense leads are connected directly to the large bullet connectors on the LiPo pack.

A few things need to be said about this hookup:

- Do not charge at a higher rate than the balancer can endure.
- Observe all proper polarities.
- Observe the balancer manufacturer's directions.
- Make sure that the sense lead connections are made very close to the pack connectors.

In this case, we can be assured that under normal circumstances, the voltage drop across the bullet connectors will be very low, as they are high quality connectors designed for this purpose, so physically, the best you can do is to strip back the insulation right where the high current charge leads are soldered to the bullets and clip the sense leads at that point. There is a lot of current flowing through the power leads, but very little flowing through the sense leads, so in this case the only critical aspect of the connections of the sense leads is that they be made as close as possible to the bullet

connectors.

Let's consider how to connect another popularly configured LiPo pack:

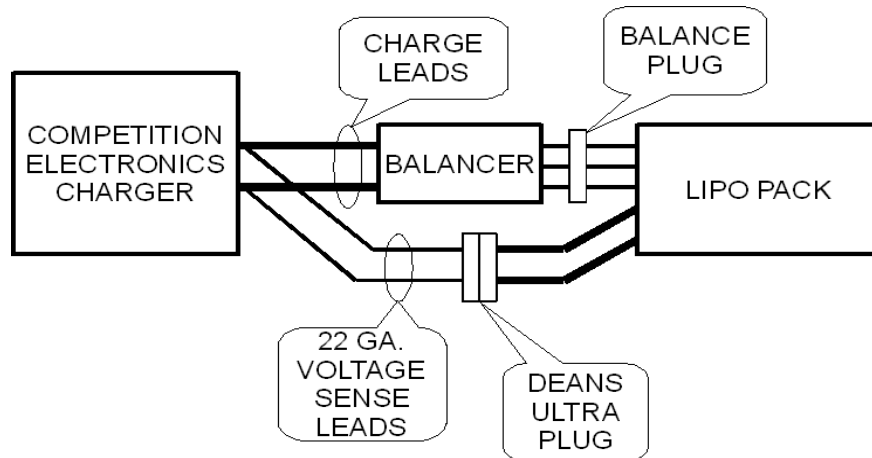

Here, the pack has a Dean's connector for the main power connections and a special pin and socket connector for the balance function.

The recommended connections for this pack are counterintuitive because in this case the charging occurs through the balance plug and the sense leads are connected to the Dean's plug. Inside a pack such as this, the balance and power connections go to exactly the same place, and as long as we don't exceed the current carrying capacity of the balance connector and it's smaller wires, this arrangement will work very well.

In this case the high current (whatever the connector and balancer will allow, since the GFX's charge rate capacity will almost certainly exceed the balancer's capability) flows through the balance plug, and that leaves the Dean's connector free to be used as a sense connection.

You should be aware of the fact that any connector/connection can fail and cause inaccuracies or hazardous conditions to occur.

If proper principles are followed, special harnesses can be constructed to make implementing these connections easy and convenient. Contact Competition Electronics for details.

Final Notes About Balancers

One should not assume that every balancer is compatible with the T35-GFX LiPo. Be alert for possible errors induced by the balancer. It is possible, though unlikely, that some balancers will not work correctly, or at all with the T35-GFX LiPo due to incompatibility issues.

Balancing with the Turbo35-GFX Alone

You can balance a pack using only the Turbo35-GFX, as follows:

- Set up the GFX for a 1C charge.
- Charge each cell of the pack individually, using the proper combination of balance and main

charge connections on the LiPo pack.

Just make sure that

- You do not exceed the current rating of the balance connector.
- You follow the principles outlined above when connecting the voltage sensing leads.

Powering up the Turbo-GFX LiPo: Selecting Cell Type

The first thing you will notice after the T35-GFX LiPo shows the sign on screen is the Cell Type selection screen. Here, you can use the rotary encoder dial to select either NimH/NiCd or LiPo chemistry. The unit defaults to NimH/NiCd but if you select LiPo and then store the setup, the next time it will default to LiPo mode. A scrolling message will appear at the bottom of the screen indicating that the T35-GFX LiPo is in LiPo mode.

NimH/NiCd mode

The NimH/NiCd operation mode is unchanged from the previous version, except that there will be a scrolling message at the bottom indicating that the unit is in NimH/NiCd mode. Please consult the original manual, found at www.competitionelectronics.com under Turbo35-GFX if you have questions.

LiPo Mode

The Turbo35-GFX LiPo mode allows charging of LiPo packs consisting of 1, 2 or 3 cells at up to 12000 mAHR rates.

LiPo packs require a constant current charge process when the voltage is below the CC/CV crossover voltage setpoint. After the per-cell voltage threshold is reached, the charge mode will switch into a constant voltage mode and maintain the pack voltage at (crossover voltage setpoint times # of cells) until current drops to roughly 3% of the mAHR setpoint. At this point the charge is terminated. Older T35-GFX units have fixed crossover voltage setpoints. Firmware revision 3.00 crosses over at 4.2 volts. Revisions between 3.00 and 3.60 cross over at 4.22 volts. A firmware upgrade is available.

The Turbo35-GFX LiPo can discharge a LiPo pack at up to a 35 amp rate. The discharge is terminated when the pack voltage reaches (3V times # of cells) while under load.

Charging with the Turbo-GFX LiPo

A charge display page has been added to the Turbo35-GFX LiPo which is very much like the existing charge page for NimH/NiCd packs. There are three significant settings for charging/discharging LiPo battery packs, as follows:

Max Charge Seconds

This is a user-settable safety time limit that will shut off the charge and signal an error if the charge time becomes equal to the setting. It is just another safety device which may be useful in the event of a malfunctioning LiPo pack. You should determine the typical charge time for a given LiPo pack at a given mAHR rate, and then set this just a bit longer.

It is also useful as a way to put a partial charge into a pack for the purpose of storage.

No of Cells

Always make sure the number of cells set into this setting agrees with the number of cells specified on the LiPo pack.

Charge mAHrs

Set this to the mAHr rating on your LiPo pack label. The Turbo35-GFX LiPo will charge at the ampere rate which will result in full mAHrs delivered in 1 hour's time. For example if you have a 3200 mAHr pack, set the mAHr setpoint for 3200 and the Turbo35-GFX will charge at a rate of 3.2 amps.

Some manufacturers of LiPo packs specify the ability to charge at 2C, or even 3C rates. Check your manufacturer's pack data to determine if this is acceptable to your pack. At the time of this writing it is generally the case that charge rates higher than 1C can shorten the life of the LiPo pack.

NOTE: Unless specifically allowed by the manufacturer of the LiPo pack in question, never exceed a 1C charge rate.

Xover V/Cell

This setting allows you to adjust the voltage at which the LiPo charge process crosses over from constant current (CC) to constant voltage (CV). The range of adjustment spans from 4.15V to 4.25V per cell. Don't forget this when setting the parameter: for example, a two cell pack will have an actual crossover voltage of twice the setting, a three cell will have three times, etc. This will allow you to get maximum performance from your cells and still not exceed ROAR specs for LiPo max voltage after charging.

Under and Overvoltage Considerations

LiPo charge will be disabled and an error message displayed if the pack voltage exceeds 4.3V per cell or if it is less than 2.3V per cell.

If the LiPo pack voltage is between 2.3V and 3V per cell, the Turbo35-GFX LiPo will try to charge the pack at approx. 10% of the mAHr rate setpoint for 2 minutes in an effort to restore the pack voltage to 3V per cell. If the pack does not return to this level after 2 minutes, the charge cycle is terminated and an error message is displayed.

Discharging with the Turbo-GFX LiPo

The Turbo35-GFX LiPo is capable of discharging continuously at up to 35 Amps. For some LiPo packs, this will cause the pack to exceed it's maximum safe temperature. Usually, this is around 140 deg F. Exceeding the maximum temperature can cause fire or explosion. Consult the manufacturer's data sheet for details concerning the maximum temperature for your pack. Always observe maximum

discharge rates specified by the manufacturer, as well. If in doubt contact them and ask them directly. The Discharge display page contains three settable parameters:

Discharge Amps

Settable between .5 and 35 amps. Observe all precautions under “Discharging with the Turbo35-GFX LiPo, above.

No of Cells

Always make sure the number of cells set into this setting agrees with the number of cells specified on the LiPo pack.

AIR On/Off

For higher charge rates, the Turbo35-GFX LiPo will measure actual internal resistance at 121 seconds into the discharge cycle. AIR measurement is disabled for discharge rates of 10 amps and below.

Under and Overvoltage Considerations

NOTE: As with charging, there are under and over voltage checks built in which will terminate discharge if it can be determined that there is an abnormality.

Cycling with the Turbo-GFX LiPo

Cycling in LiPo mode works as you would expect; it first runs the LiPo charge and then the LiPo discharge functions.

Storing and Retrieving Program Setups

Storage and retrieval of setups works the same way as with the original T35-GFX, however, there are only 5 setups available in NimH/NiCD mode and 5 setups available in LiPo mode. See the T35-GFX manual for details.

Generic setups have been provided for both NimH/NiCd and LiPo packs as a starting point and a convenience to the user. It is the responsibility of the user to understand, select and adjust these setups to suit specific packs.

This manual and its contents ©2007-2008 Competition Electronics, Inc.

Competition Electronics, Inc

3469 Precision Dr.

Rockford, IL 61109