

OZONO

with Aqueous Ozone Technology

OZPro

User Manual

OZONO Australia Pty Ltd

www.ozono.world

© OZONO Australia Pty Ltd 2024

Introduction

Congratulations on your purchase of OZONO OZPro with Aqueous Ozone Technology - The Chemical-Free Cleaning System. With this device, you will no longer need to use detergents, softeners or cleaning chemicals. We believe OZONO OZPro will prove to be a wonderful addition to your home and lifestyle. To maximise the benefits of your new OZONO OZPro, please read through this manual.

Important Safety Information

- Do not consume the aqueous ozone water.
- Aqueous ozone water is a natural oxidant and long exposure in it may cause dry skin.
- Check that the adaptor is not damaged before using.

Warning

1. Check that the voltage indicated on the adaptor corresponds to the local mains voltage before using the device.
2. Install the device in a well ventilated place.
3. Do not mount device vertically or at an angle.
4. Do not exceed the maximum water inlet pressure of 100psi.
5. Use **only COLD water** with the device. Heated water will reduce the effectiveness of aqueous ozone.
6. Unplug the product if not used for an extended period.
7. Disconnect ALL power supplies before servicing.
8. Do not operate the device with the cover removed.
9. Do not cause the device to become wet.
10. Use only a soft, damp cloth to clean the device.

Specification

Model	OZPro
AC Adaptor Electrical Input	AC 100-240V / 50-60Hz
Ozone Level	0.5-1.0mg/L
Water Pressure	20~100psi
Operating Temperature	COLD water only
Product Dimension	47.7cm x 24.3cm x 9.9cm
Net Weight	2kg

What's in the box?

On opening box, please check and contact us if any component is missing.

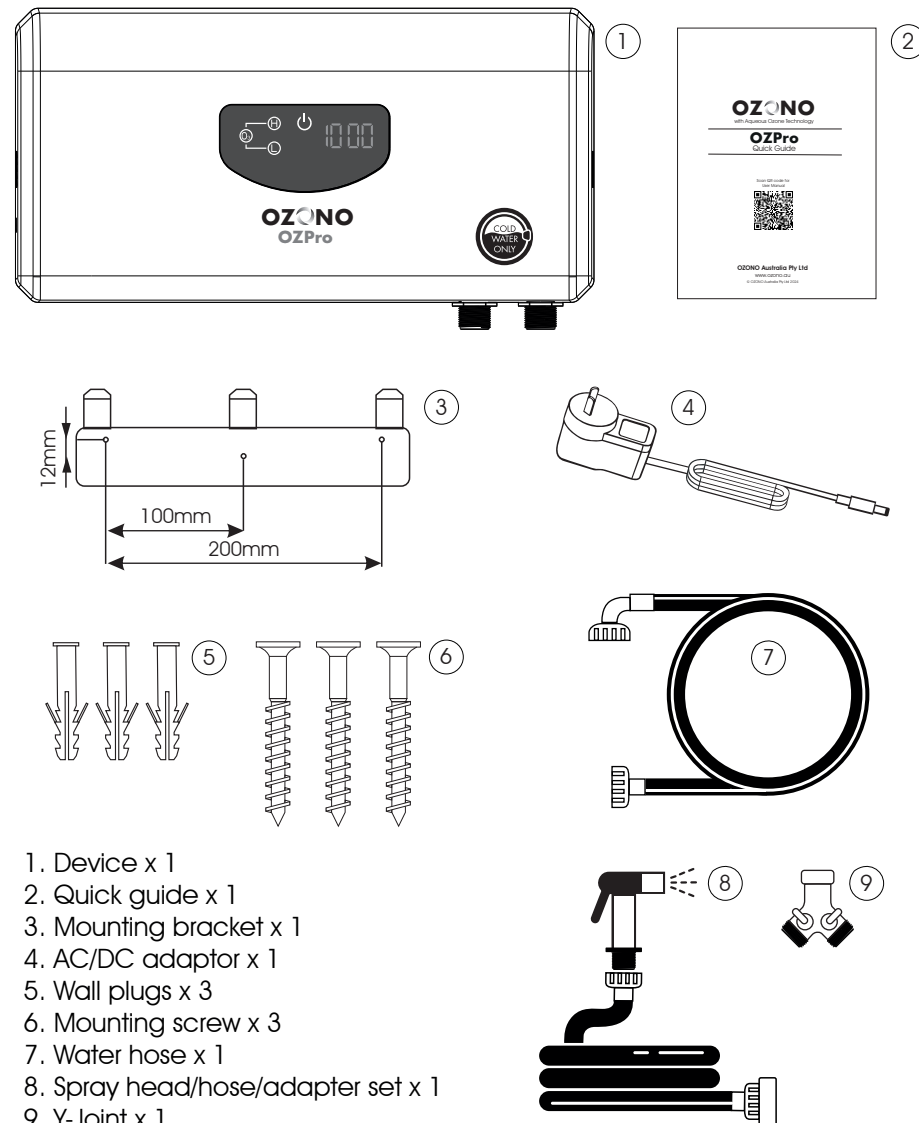

Before installing OZONO OzPro

- Whenever possible, do not use an extension cord.
- Do not use any other AC/DC adaptor other than the one provided with your OZONO OZPro.
- A minimum water pressure of 20psi and a maximum of 100psi is required for your device to operate efficiently.
- Do not use any water hose with metal screw caps.

Installing the OZONO OZPro

Ideally, OZONO OZPro should be installed above or near your washing machine for easy access. Where this is not possible, it is acceptable to vary this requirement as long as the device remains accessible.

Mount the bracket with the 3 mounting screws provided. Use a spirit level to ensure that the bracket is horizontal. There are 3 mounting slots on the back of OZONO OZPro.

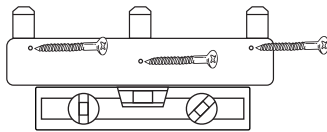

Spirit level (not included)

Gently slide the device over the aligning protrusions. Check that the device is hanging securely.

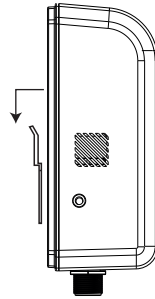

Turn off the tap connected to your washing machine. Disconnect the water hose from the water inlet of your washing machine. Turn on the tap for a few seconds to clear the hose.

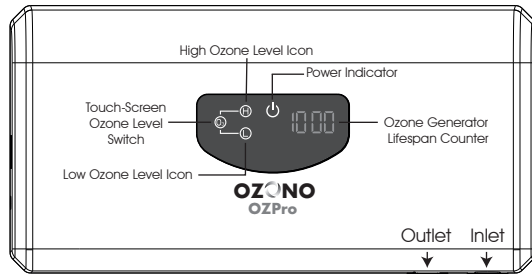

Then connect the water hose to the INLET of the OZONO OZPro. Please do not overtighten, just ensure that there is a secure fit.

Attach the provided Y-Joint to the OUTLET of the OZONO OZPro. Then connect one end of the provided hose to it and the other end to the inlet of your washing machine.

Connect the provided spray head/hose to the free valve of the Y-Joint. Do not overtighten, just ensure that the fit is secure.

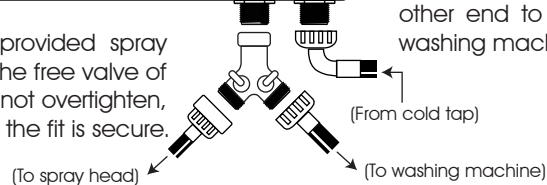

Turn on the water faucet slowly. Check to ensure that there is no leakage from any of the connecting points. Switch on the power.

Indicators & Alarm System

The touch-screen LED panel on the front of the OZONO OZPro shows the various states of operation when the device is activated.

1. Representation of the various icons:

- O₃ icon is the touch-screen button to select the ozone concentration level.
- Neither L nor H icon is lighted: ozone generator has been switched off.
- L icon is lighted, ozone generator has been set to LOW.
- H icon is lighted, ozone generator had been set to HIGH.
- The activation sequence when the O₃ icon is depressed is as follows: OFF -> H -> L -> OFF -> H -> L -> OFF
- Power Indicator in Red: OZONO OZPro is currently in Sleep mode.
- Power Indicator in Blue: OZONO OZPro is activated.

2. The numerals on the LED Panel show the remaining lifespan of the ozone generator in hours. The module is estimated to last 1,000 hours of water flow.

3. Please replace the ozone generator once the counter reaches 0000.

LED Touch-Screen Panel

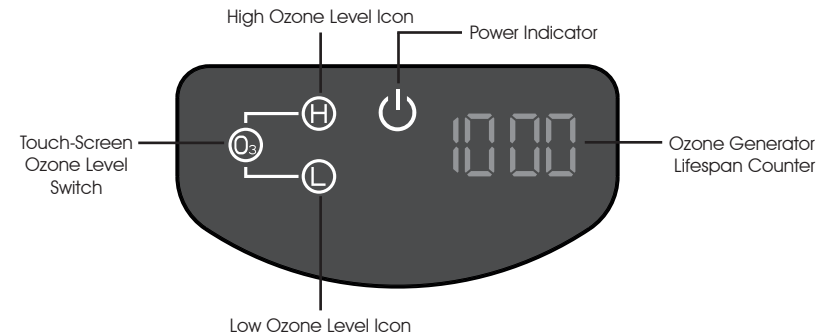

Daily Use

The OZONO OZPro is designed for easy operation. After the initial setting of the ozone level, all you need to do for your laundry process is to operate your washing machine in the usual manner.

Ozone Setting

- It is recommended to set the ozone level to HIGH for all washing machines.
- For washing machines that are of 8kg and below in size, you may choose to set the ozone level to LOW.
- It is recommended to set the ozone level to HIGH if you are washing items that are very soiled or with strong odours.
- Please set ozone level to HIGH for mopping floors and other cleaning purposes.

Stains

- As with detergents, stains should be pre-treated prior to the laundry process.
- There is no need for any extra steps for normal soiled laundry.

Precautions when using a top load washing machine

- To prevent possible colour loss, we recommend placing light coloured items at the top of the pile, leaving the darker ones at the bottom when loading your laundry into the washing machine.
- This will prevent the dark coloured garments from any potential bleaching by the most concentrated stream of ozonised water at the start of the wash.

Recommended washing machine setting

- Use the COLD water setting when using OZONO OZPro.
- The ideal washing machine setting is a 2-wash cycle.
- As there is no detergent used, there is no need for any rinse cycles that is typically required in the normal laundry process.

Drying Mode

In order to keep your OZONO OZPro in tip-top condition, a drying mode will be activated when the unit has been inactive for 2 hours. This process may run for a few hours depending on the extent of the humidity detected in your OZONO OZPro. It will just run its process silently in the background and will not affect the normal laundry process.

Keeping Your OZONO OZPro Clean

- Use a soft, damp cloth to keep your OZONO OZPro clean.
- Do not use any cleaning agents.

Lifespan of the ozone generator module

The ozone generator module is estimated to last 1,000 hours of water flow. This means that if the total time taken for the water flow of each of your laundry cycle is 20 minutes, the ozone module is estimated to last 3,000 washes.

The counter on the LED panel will start counting down from 1000. Once it reaches 0000, it would mean that the ozone generator module is spent. Please contact OZONO Customer Service for a replacement. Note that a service fee and charges for parts apply.

Frequently Asked Questions

1. Is the aqueous ozone able to remove stains?

Ozone works well for normal soiled laundry. Sweat, surface dirt, odours are effectively removed in an ozone laundry wash. For the removal of stains, ozone works similar to detergents. Surface and loosely bonded stains can generally be removed during the normal wash cycles. For tough or stubborn stains, pre-wash treatment with a stain remover is recommended.

2. Does the aqueous ozone work for all types of water?

Aqueous ozone will generally work well with most household water. However, the better the quality of the water in your area, the more efficient aqueous ozone will be. If you have hard water in your area, we recommend using a pre-filter or water softener prior to the laundry process. Use **only COLD water** with your washing machine.

3. What types of washing machine works with OZONO OZPro?

The OZONO OZPro Chemical-Free Cleaning System works with all types of washing machines. We recommend using a High Ozone Level setting for top-load washing machines as they use more water.

4. Do I need to use hot water with my OZONO OZPro?

Use **only COLD water** in your laundry process with the OZONO OZPro. Ozone breaks down easily in hot water and will render it ineffective in your laundry cycle. With OZONO OZPro, you no longer need hot water in order to kill viruses, bacteria and other microbes when washing.

5. What else can I use OZONO OZPro for?

The OZONO OZPro Chemical-free Cleaning System can be used as a multi-purpose cleaner for various surfaces. It works as a natural sanitising agent as you clean the floor and surfaces in your home. However, please note that the effectiveness of the ozone water after collection from the OZONO OZPro is only 30 minutes.

6. What parts of my OZONO OZPro will need replacing?

The ozone generator is estimated to last about 1000 hours of water flow and needs to be replaced when the counter numerals show 0000.

Troubleshooting

1. OZONO OZPro fails to activate.

- Check if the power supply is properly and securely connected.
- Check if both hoses to the Inlet and Outlet of the OZONO OZPro are connected properly.
- Check if the water faucet has been turned on.

2. When the counter numerals show 0000, it would mean that the ozone generator's lifespan is spent. A replacement ozone generator will be needed. Please contact OZONO Customer Service for assistance.

3. Laundry doesn't feel clean and it doesn't smell fresh.

- Check if either the L or H icon is turned on. If not, then the ozone generator has been switched off. To switch on the ozone generator, please depress the Ozone Level Touch-screen Selector.
- If the L icon is turned on, the ozone generator has been switched to Low mode. You may have too large a load of laundry and will need to use the high setting. Please depress the Ozone Level Touch-screen Selector till you see the H icon lighted.
- Ensure that the water temperature is set to "Cold". Hot water will reduce the effectiveness of the aqueous ozone.
- Ensure that there is sufficient water to fully submerge the items.
- Check if the counter shows 0000. If so, it would mean that the ozone generator has reached the end of its lifespan. Please contact OZONO Customer Service about replacing the ozone generator module.

4. Detergent bubbles can be seen in the wash process.

- Detergent residues are either being flushed out from your garments or the washing machine drum.
- These residues should disappear after a few wash cycles.

Parts and Controls

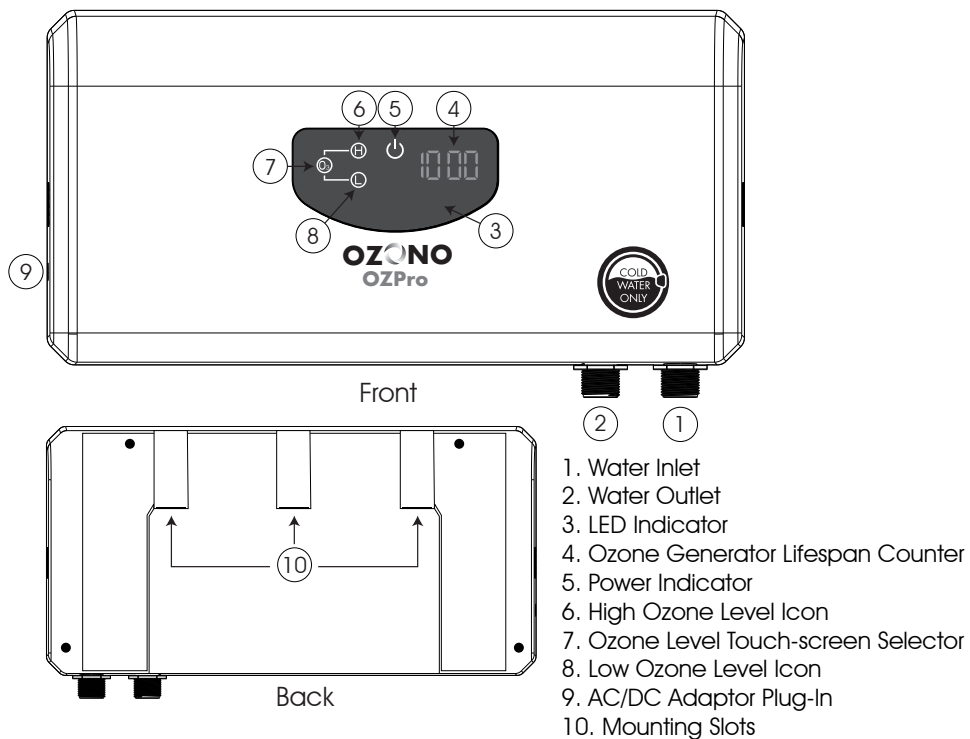

Dimensions

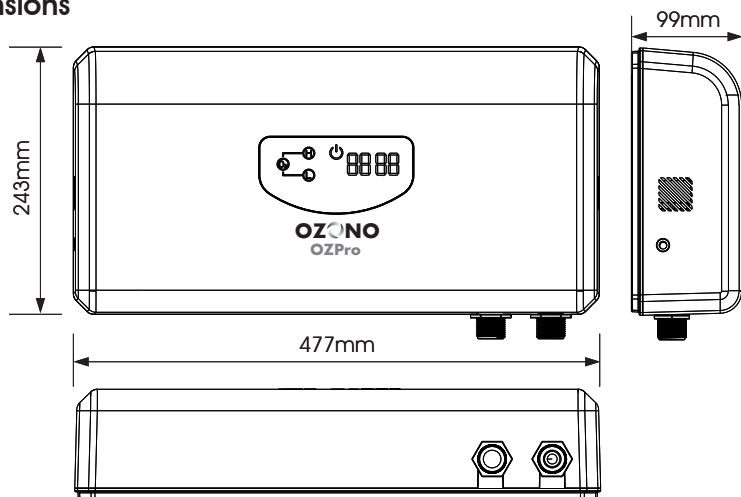

Warranty & Support

1. Your new OZONO OZPro is warranted to be free of any defects in material and workmanship at the point of shipment.

2. This warranty only covers normal household usage for a period of ONE (1) year from the date of purchase.

3. Please keep the original receipt as proof of purchase.

4. If the device is found to be defective during the warranty period due to a manufacturer's defect, necessary repair(s) will be provided free of charge.

5. The warranty is deemed void in the following situations, and repair / replacement cost(s) shall be borne by the customer:

(i) Water inlet / outlet from device is damaged due to incorrect use of the Connecting Hose.

(ii) The device is dropped resulting in damage(s).

(iii) Outer damage(s) due to exposure to use of harsh / corrosive chemicals.

(iv) The device is damaged due to use of incorrect voltage.

(v) Dismantling of the device by anyone else other than our authorised personnel.

(vi) Damage(s) due to user's failure to follow the correct instructions stated in this manual.

(vii) Damage(s) due to user's negligence or misuse.

(viii) Damage(s) to device due to a natural disaster.

For more information, please contact OZONO Australia Pty Ltd at:
info@ozono.au