

Read all instructions BEFORE assembly and USE of product. KEEP INSTRUCTIONS FOR FUTURE USE

IMPORTANT, RETAIN FOR FUTURE REFERENCE
PLEASE READ CAREFULLY

Boori International

AUSTRALIA
 18-20 Charles Street
 St.Marys Sydney NSW
 2760 Australia
 Ph: 61 2 9833 3769
 Fax: 61 2 9673 4240



Boori (UK) Ltd
 Unit 1, Transigo,
 Gables Way, Kennet Park,
 Thatcham, Berkshire,
 RG19 4ZA
 Ph: (44) 016 3529 5670
 Fax: (44) 016 3587 7552

Boori USA LLC
 20 Chapin Road, Ste 1001
 Pinebrook, NJ 07058
 Ph: +1 973 577 6933
 Fax: +1 973 577 6934

JAPAN
 401A, 4-2-10 Kitakyuhoji-machi,
 Chuo-ku, Osaka 541-0057 Japan
 TEL: 06-4963-3939
 FAX: 06-4963-3900
 E-mail: info@boori.co.jp

Instructions for the Boori Country USA NEWPORT CRIB FOREVER

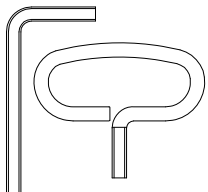
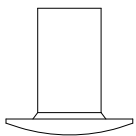
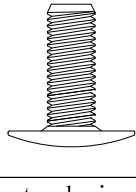
Hardware and parts list

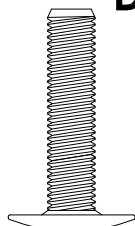
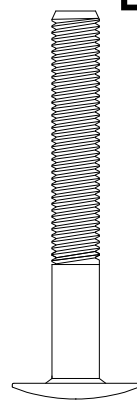
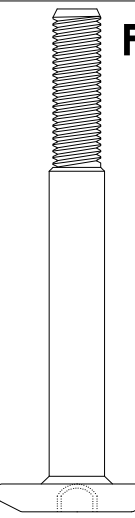
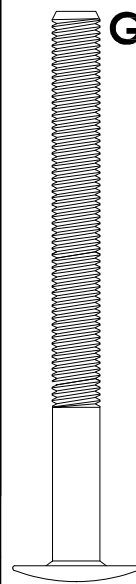
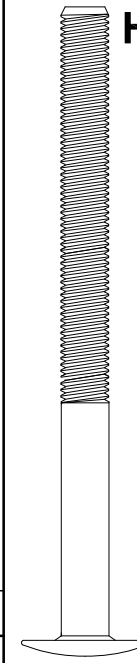
2 x Allen Keys	6 x M6*14mm Capping nuts	2 x M6*18mm Connecting bolts	2 x Ø8*30mm Wooden dowels	4 x M6*28mm Connecting bolts	4 x M6*54mm Connecting bolts	3 x M6*60mm Connecting bolts	4 x M6*70mm Connecting bolts	4 x M6*80mm Connecting bolts
	 A	 B	 C	 D	 E	 F	 G	 H
	Preassembled	Actual size		Preassembled Actual size	Actual size	Actual size	Actual size	Actual size

1x Cap of headboard

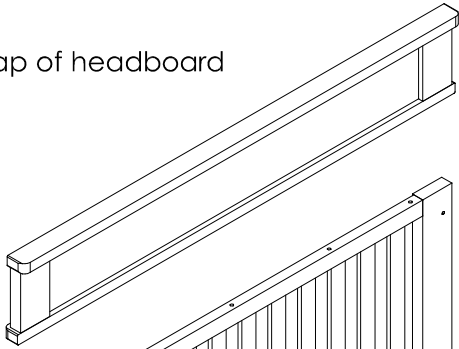

1x Headboard

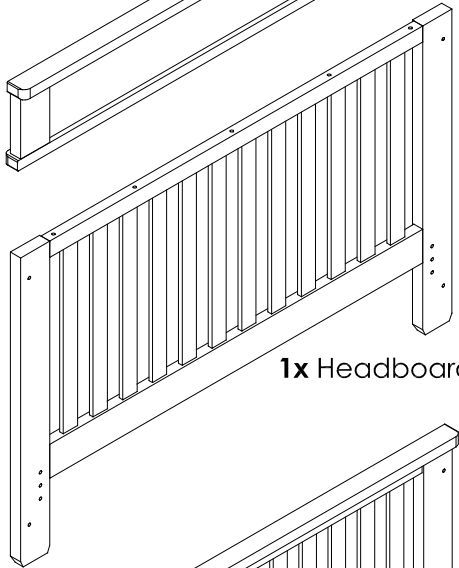

1 x Footboard

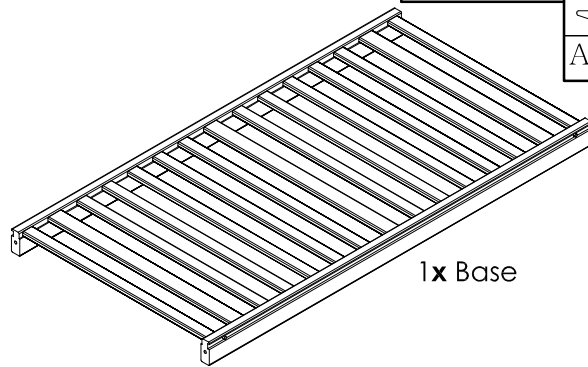
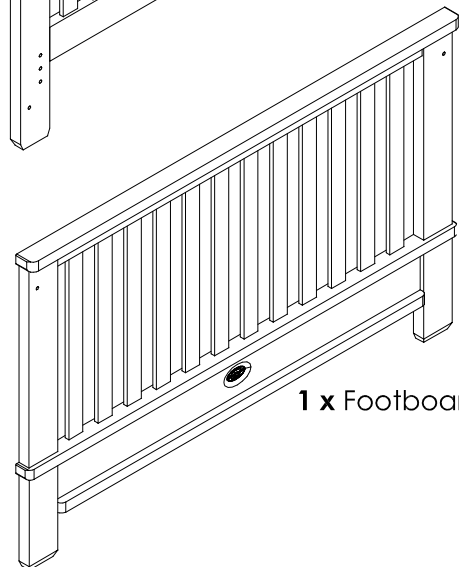

1x Base

A+D
(Preassembled)

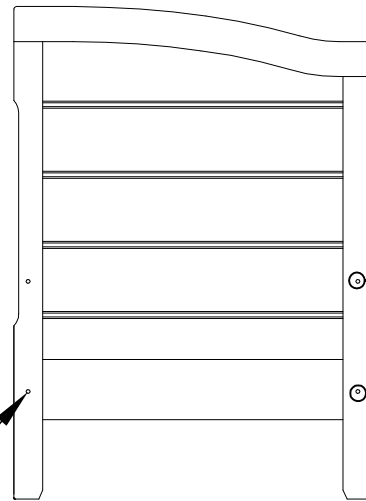

2 x Side Panel (Identical)

⊙ **Top Hole**
(For high base position)

⊙ **Bottom Hole**
(For low base position)

Assembly as a cot

Stage 1: Cap of headboard on to the headboard and then screw 3 X F Connecting bolts and 2XC Wooden dowels

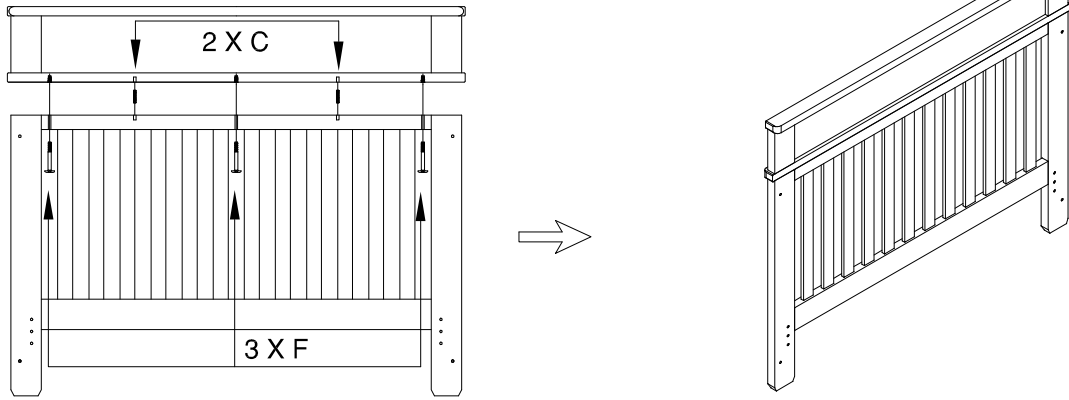

Stage 2: Connect Headboard panel to the two side panels with the 2 XE and 2XH connecting bolts provided. tighten all the connecting bolts (Do not over tighten)

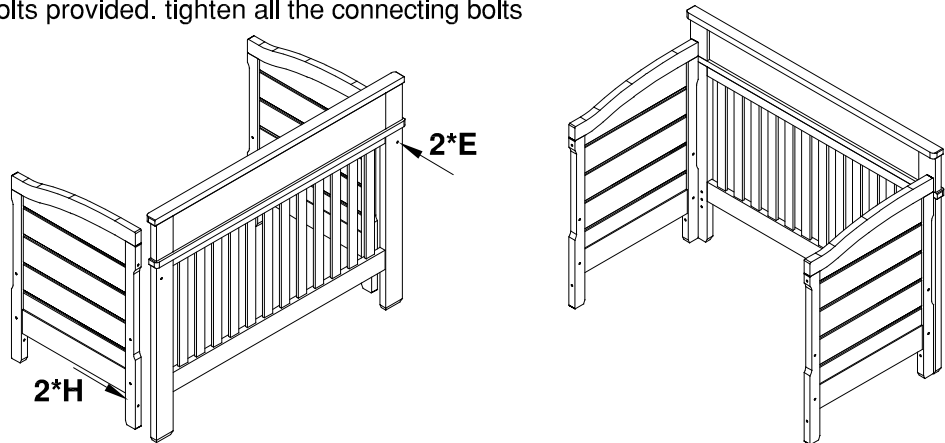

Stage 3: Connect mattress base to the two side panels with the 4 XG connecting bolts provided.

Note: **Top Hole** for the newborn position
Bottom Hole for baby position.

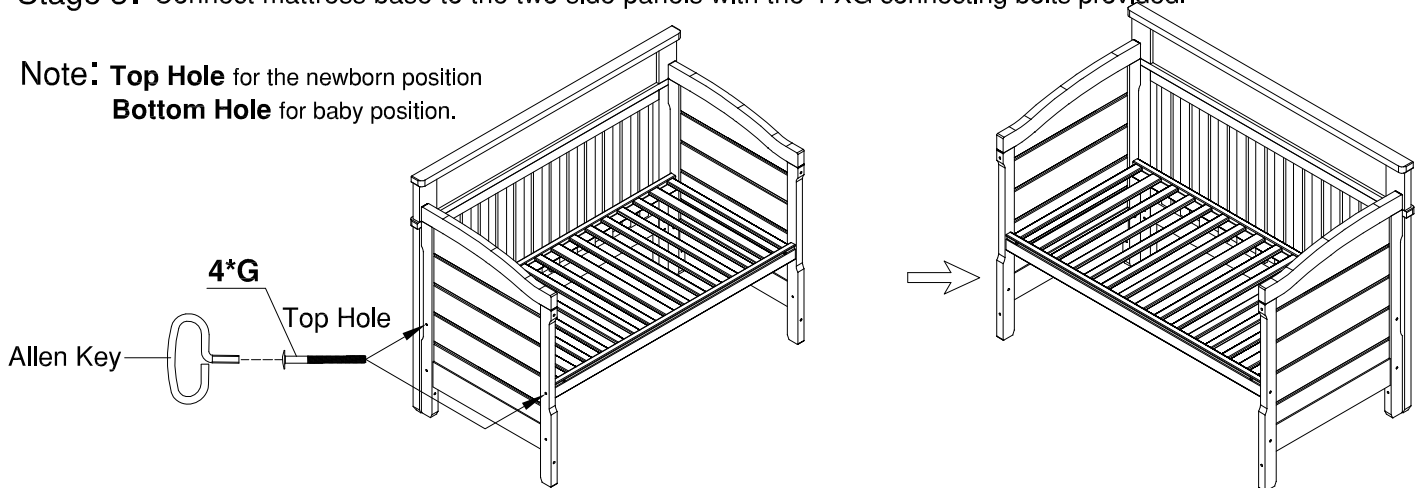

Stage 4: Connect Footboard to the two side panels with the 2 XE and 2XH connecting bolts provided. tighten all the connecting bolts (Do not over tighten)

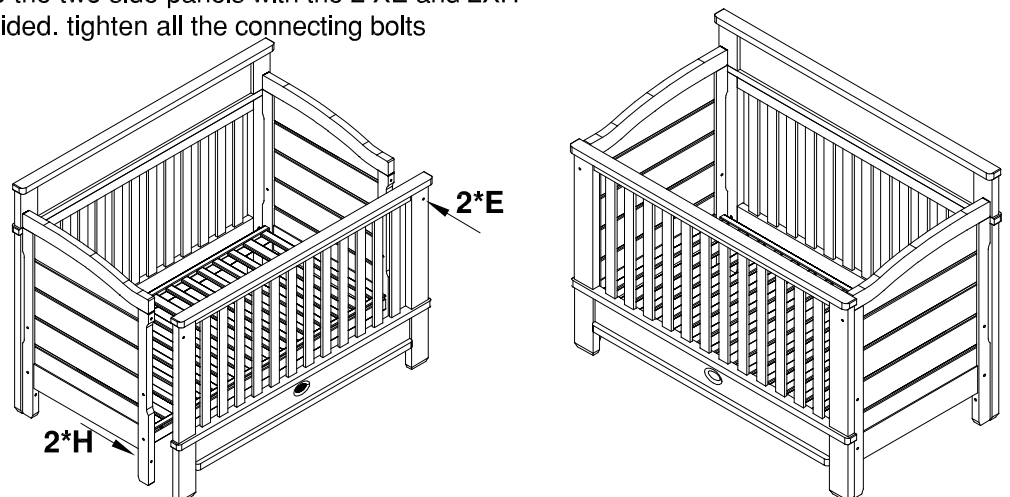

Assembly as a cot

Note:

When child is able to sit up adjust mattress/base to the lower position (bottom hole) and remove bumper pads, large toys and other objects that could serve as steps for climbing out.

Remove 4*(A+D) preassembled from the bottom holes of side panels and block top holes with 4*D connecting bolts and 4*A capping nuts provided.

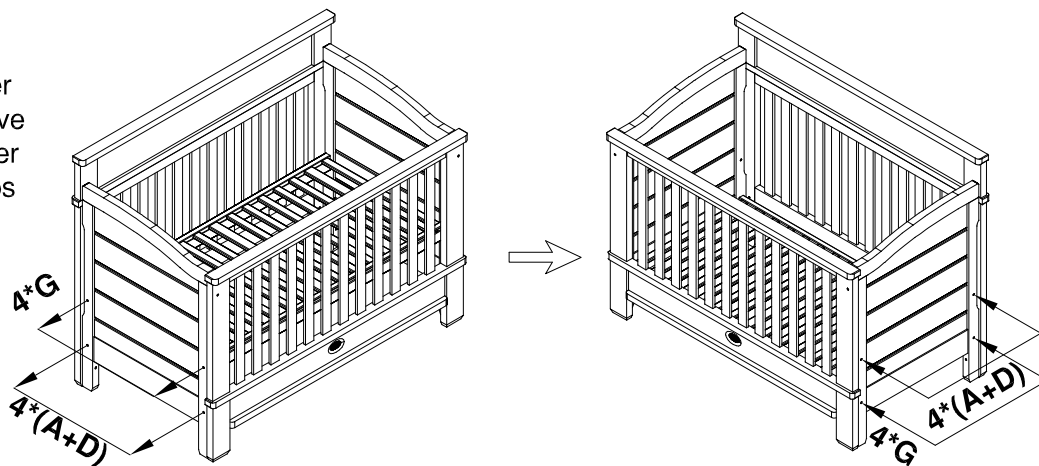

Converting to the Sofa

Stage 1: Reposition the base to the lower position (bottom hole of Footboard)
Screw all bolts loose and remove two fixed sides

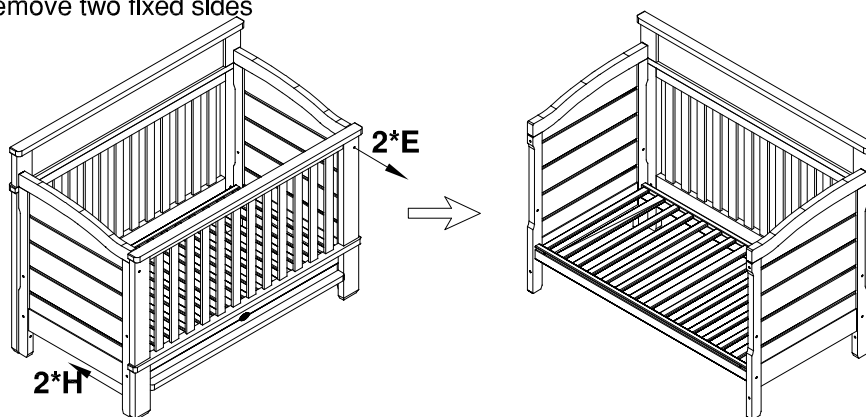

Stage 2: Block the top holes with the 2*E connecting bolts and 2*A capping nuts provided
Block remaining holes on the side panel with 2*B connecting bolts

