

***IMPORTANT, RETAIN FOR FUTURE REFERENCE*
PLEASE READ CAREFULLY**

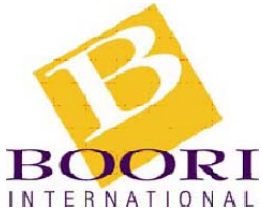



Boori International

AUSTRALIA
18-20 Charles Street
St. Marys Sydney NSW
2760 Australia
Ph: 612 9833 3769 Fax: 612 9673 4240

Boori (UK) Ltd
Unit 8, Transigo,
Gables Way, Kennet Park,
Thatcham, Berkshire,
RG19 4ZA
Ph: (44) 016 3529 5670 Fax: (44) 016 3587 7552

Boori Country Classic Changer

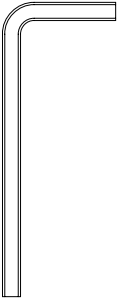
Classic Changer Hardware and parts list

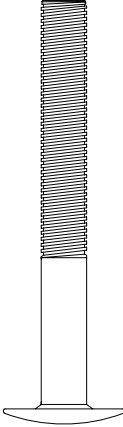
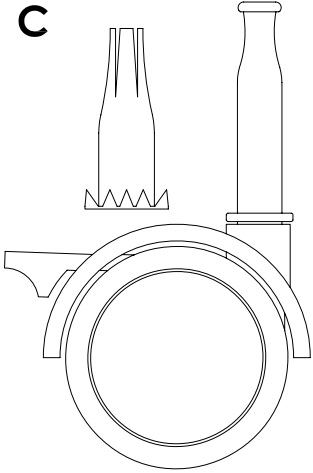
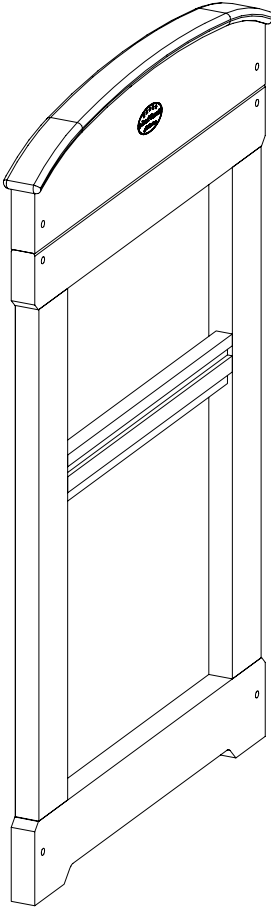
1 x Allen Keys	16 x Iron dowels	12 x 54mm Connecting bolts	4 x Castor & sleeve
	<p>A</p> 	<p>B</p> 	<p>C</p> 
<p>1 x Change Table Head</p> 		<p>Actual size</p>	

1 x Change Table Foot

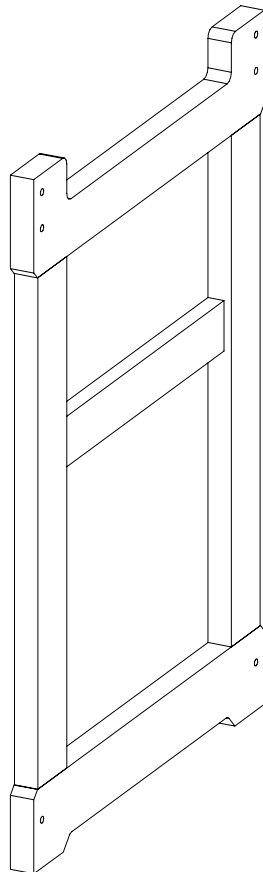

2 x Top side rails

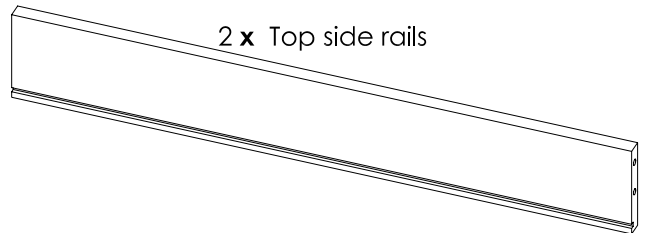

2 x Side rails

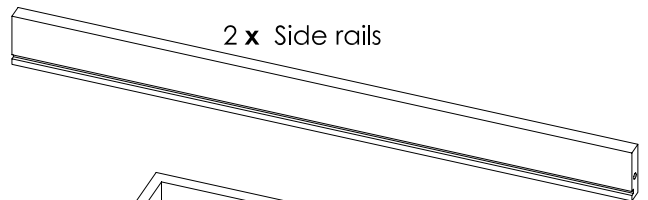

1 x Drawer

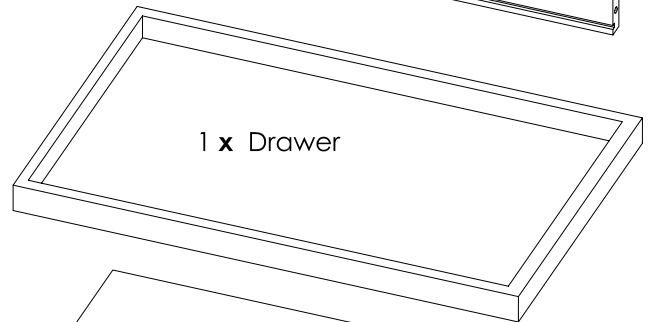

2 x Shelf base

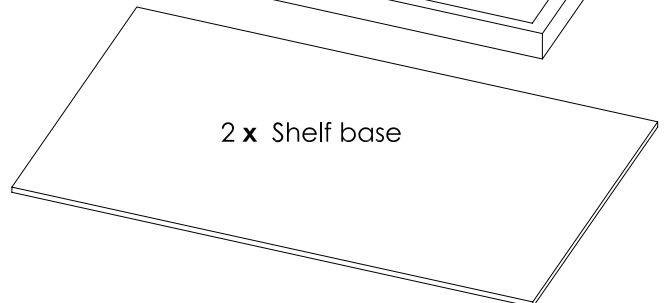



Boori classic changer assembly instructions

Stage 1: Preparing the head and foot panels

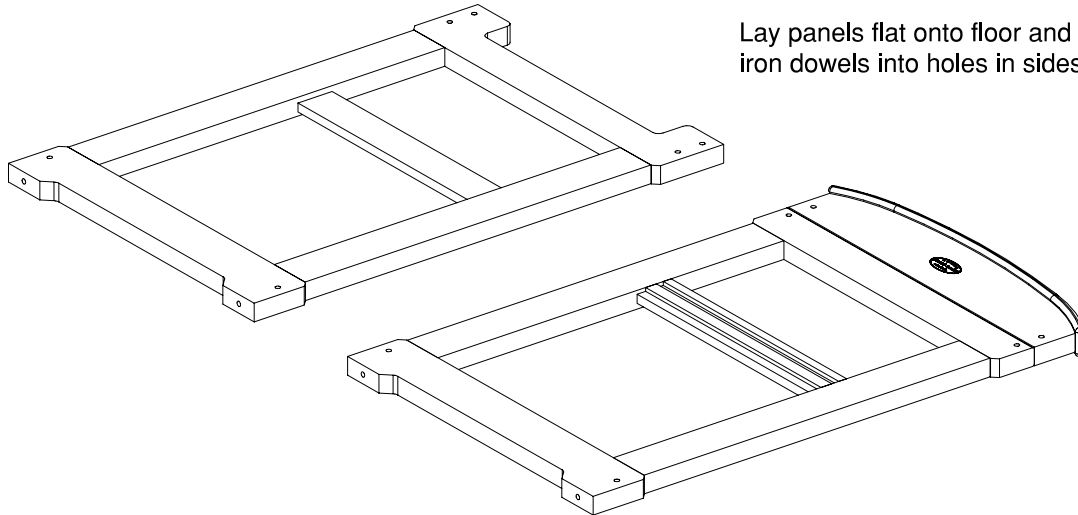

Lay panels flat onto floor and place 16 X A iron dowels into holes in sides.

Stage 2: Attaching the side rails to head panel

Make sure your grooves on the side rails for the shelf bases are facing the inside of the change table.

Lay your back panel on to its side and screw in 2 X top side rails and 2 X side rails using 6 X B bolts.

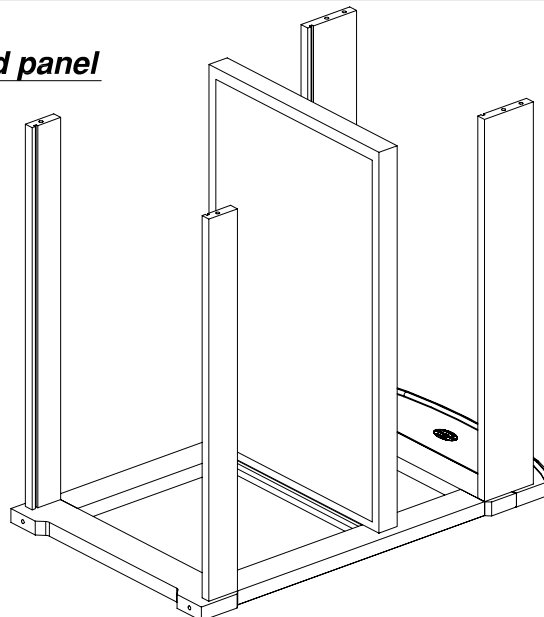

Stage 3: Attaching shelf bases

Slide 2 X **Shelf bases** into side rails making sure the stained side is right side up.

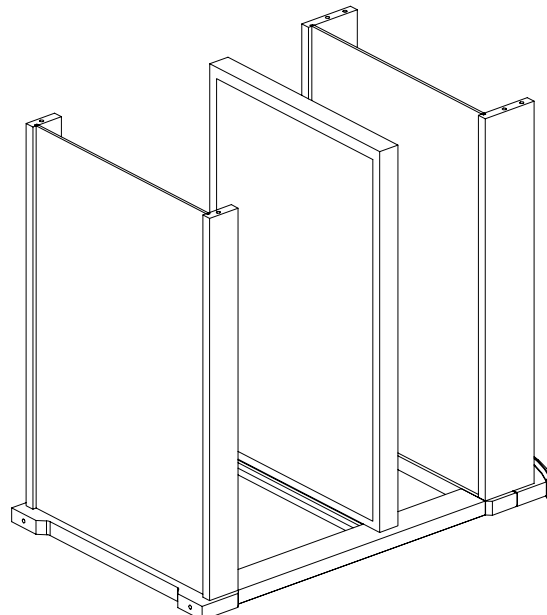



Boori classic changer assembly instructions

Stage 4: *Attaching front panel*

Push the front panel onto sides and screw using 6 X B bolts.

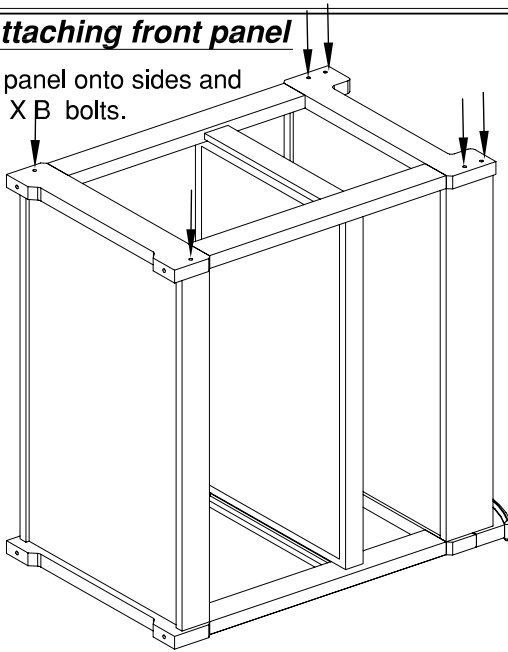

Stage 5: *Attaching castor & sleeves*

Gently hammer in 4 X Castor sleeves into the castor sleeve holes at the bottom of the change table and then push in 4 X Castors.

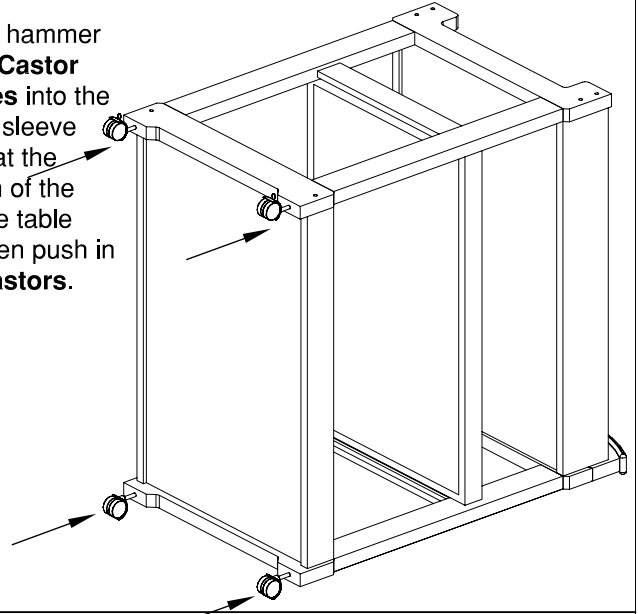

Stage 6: *Attaching the changing pad*

After standing your change table upright push down onto the corners to make sure castors click into place.

RECOMMENDED CHANGING PAD SIZE 800mm X 480mm X 25mm
This changer table has been manufactured for use with a pad which measures 480mm wide by 800mm long and a maximum thickness of 30mm.

Put the changing pad onto the top of the changer.

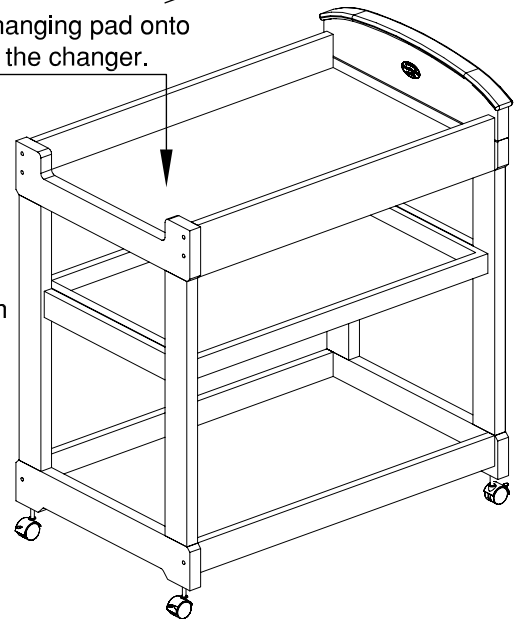

Boori Classic changer table

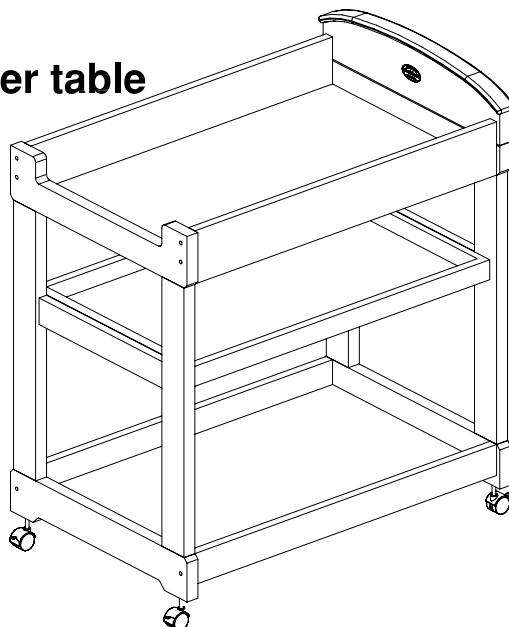

WARNING:

- * Please ensure that the brakes on all four castors are released before moving the cradle;
- * Regularly check your cradle to ensure that all the rocking bars are in their correct positions, and the capping nuts are tightly fitted.



Boori Country Furniture

IMPORTANT-RETAIN FOR FUTURE REFERENCE READ CAREFULLY

Congratulations and thank you for choosing Boori country product(s). The furniture you have purchased is constructed from high quality materials for strength and durability. Here are some tips on how you can preserve its beauty for a long time.

1. Do not expose furniture to strong sunlight, direct heat sources, extreme changes in temperature or moisture.
2. Wipe up spills immediately with a soft, clean cloth.
3. Urine spills on furniture can cause discolouration.
4. Clean furniture by wiping the surface with a soft cloth dampened with water.
5. If necessary clean furniture using a mild soap solution and wipe clean with a soft cloth dampened with water and then dry with soft clean cloth.
6. Do not use strong household cleaners.
7. Always wipe in the direction of the grain in the wood do not wipe in a circular motion.
8. Avoid contact with sharp objects, or containers containing hot liquid.
9. Avoid contact with 'rubber feet' on items such as radios, computers, telephones etc. Use a felt mat (not plastic) to protect furniture surfaces.
10. When moving furniture do not drag always lift and place in position.

FALL HAZARD-To prevent death or serious injury, always keep child within arm's reach.

- Read all instructions before use of the changing table.
- Keep instructions for future use.
- Do not use changing table if it is damaged or broken.

WARNING

- This product is not intended to be used as a table. Use of the product without instruction may result in death or serious injury to your child from falling. Follow all instructions on attaching and using the changer.
- When lockable castors/wheels are fitted, they shall be locked when the changing unit is in use;
- Additional or replacement parts shall only be obtained from the manufacturer or distributor;
- Do not leave the child unattended.
- All assembly fittings shall always be correctly tightened and checked regularly.
- Be aware of the risk of open fires and other sources of strong heat, such as electric bar fires, gas fires, etc, in the near vicinity of the changing unit.
- Weight of the child for which the product is intended up to a maximum weight of 15kg.
- **Do not to use the changing unit when any part is broken, torn or missing.**

Warranty

All Boori products carry a full five(5) year manufacturer's warranty as testimony to the quality and longevity of the range. This warranty excludes general wear & tear and damage caused by the product not being used in accordance with its instructions or the care instructions.

During this guarantee period Boori will replace or repair any defective part. In the event of a product being replaced, as a whole unit or part there of during the guarantee period, the guarantee on the replacement will expire five(5) years from the original purchase date.

This guarantee excludes accidental damage, misuse and or improper transporting and handling.

The warranty is void if the original product has been altered in design or colour in anyway.

All warranty claims must be lodged at the place of original purchase and proof of purchase must be provided in order to lodge a warranty claim.

Maintenance of your Boori Country Furniture

- * **TO ENSURE THE SAFETY OF YOUR COT, BED OR CHANGE TABLE, REGULARLY CHECK ALL THE CONNECTING BOLTS AND GLIDE PINS MAKING SURE THEY ARE TIGHT, CARE SHOULD BE TAKEN THAT NO SCREWS ARE LOOSE**
- * **GLIDE PINS AND BOLTS SHOULD BE TIGHTENED EVERY FOUR TO SIX MONTHS TO ENSURE COT/FURNITURE REMAINS STABLE**
- * **TO CLEAN YOUR COT & FURNITURE USE A SOFT CLOTH DAMPENED WITH WATER**
- * **DO NOT USE STRONG HOUSEHOLD CLEANERS**
- * **AVOID CONTACT WITH SHARP OBJECTS**
- * **WHEN MOVING YOUR COT, BED OR FURNITURE DO NOT DRAG, ALWAYS LIFT AND PLACE IN POSITION**