

# Boori

## Universal

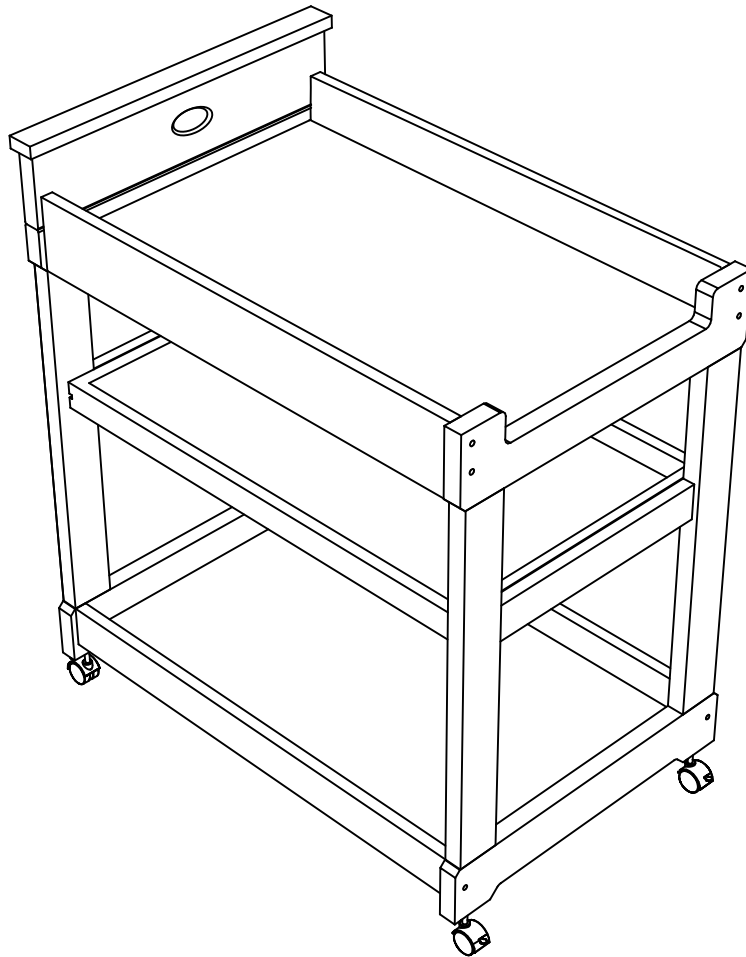

## Squared 3 Tier Changer



**IMPORTANT:**

**PLEASE READ THE INSTRUCTIONS CAREFULLY  
AND KEEP FOR FUTURE REFERENCE**



**IMPORTANT:THE ASSEMBLY OF THIS PRODUCT REQUIRES TWO PEOPLE  
READ ALL INSTRUCTIONS BEFORE ASSEMBLY AND USE OF THE PRODUCT.**

Boori Australia Pty Ltd  
18-20 Charles Street  
St. Marys Sydney NSW  
2760 Australia  
Ph: 61 2 9833 3769  
Fax: 61 2 9673 4240  
www.boori.com.au



Boori (Europe) Ltd  
Unit 1,Transigo  
Gables Way  
Thatcham,Berkshire,  
RG19 4JZ  
Ph: (44) 016 3529 5670  
Fax: (44) 016 3587 7552  
www.boori.co.uk

Halim & Boori Company  
10F.Halim INT'L B/D, #1674-4,  
Secho-Dong, Seocho-Gu,  
Seoul, Korea  
Tel: +82-2-598-1470  
Fax: +82-2-583-8885  
E-mail : ted@boori.co.kr  
Postal code: 137-725.

ブーリジャパン(株)  
〒541-0057  
大阪府大阪市中央区北久宝寺町  
4-2-10  
Ph : 06-4963-3939  
Fax : 06-4963-3900  
E-mail : info@boori.co.jp

## Instructions for Boori Universal Squared 3 Tier Changer (B-SQCH)

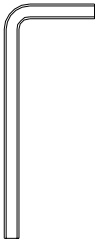
### Hardware and Parts List

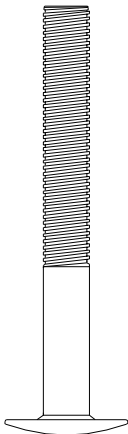
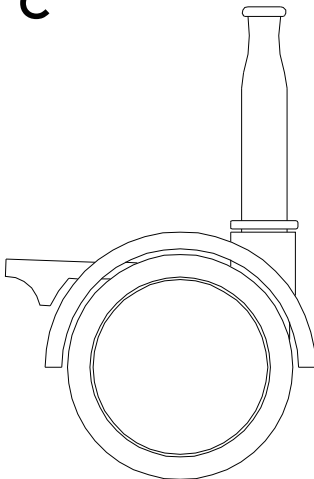
1 x Allen Key	16 x Iron dowels	12 x Connecting bolts	4 x Castors
	<b>A</b> 	<b>B</b>  Actual size	<b>C</b> 

1 x Head Panel

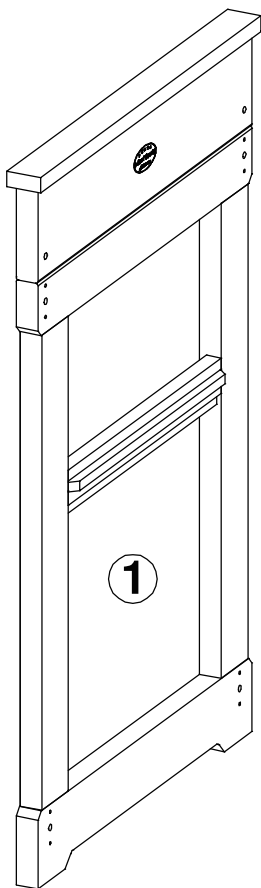

1 x Foot Panel

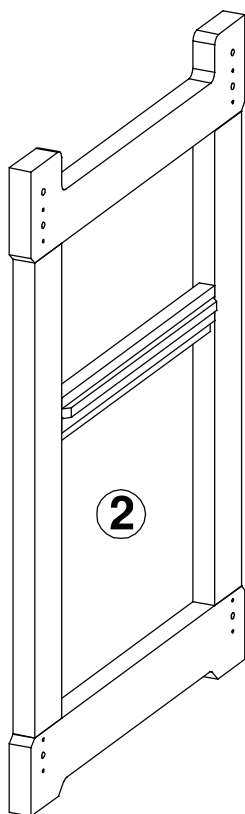

2 x Top Support Bars

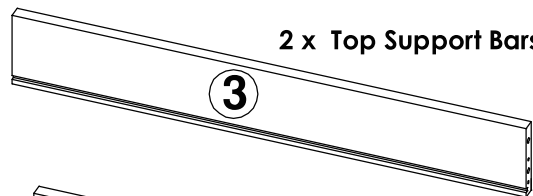

2 x Lower Support Bars

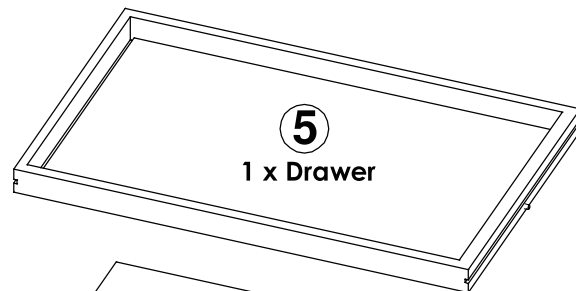

1 x Drawer

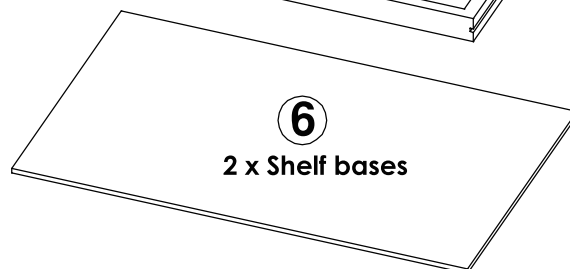

2 x Shelf bases

# ASSEMBLY INSTRUCTIONS

## Step 1: Prepare the Head Panel and Foot Panel

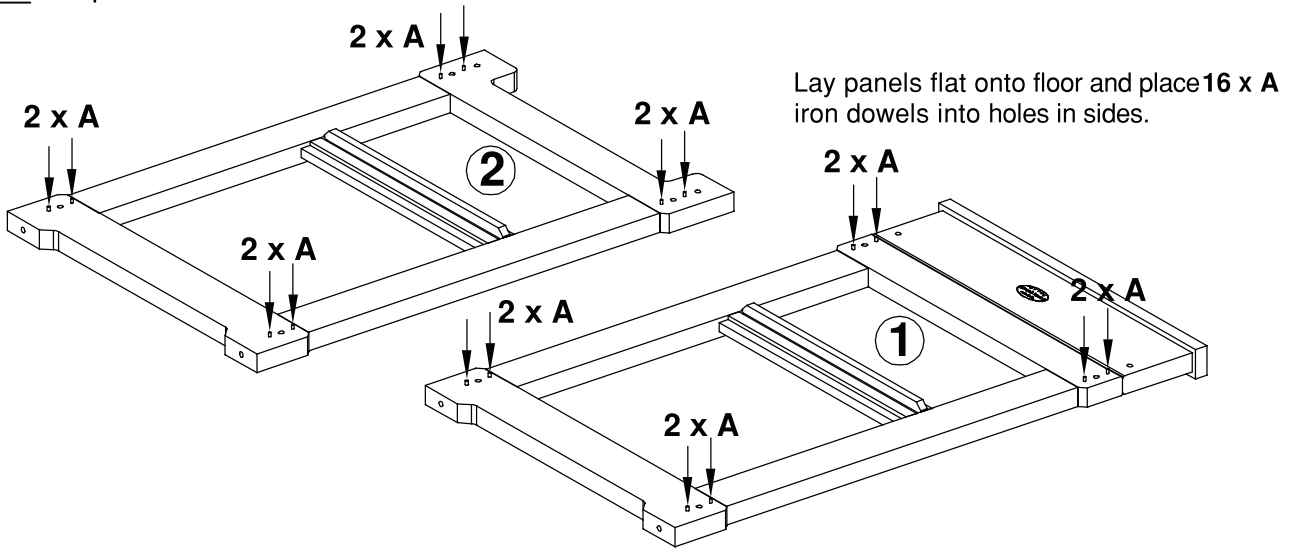

A x 16

## Step 2: Attach the Support Bars and Drawer to the Head Panel

**Note:** Make sure the groove on the Support Bars for the Shelf Base are facing inward.

Lay a Head Panel (1) onto its side and secure the Support Bars (3) (4) using 6 x B connecting bolts respectively.

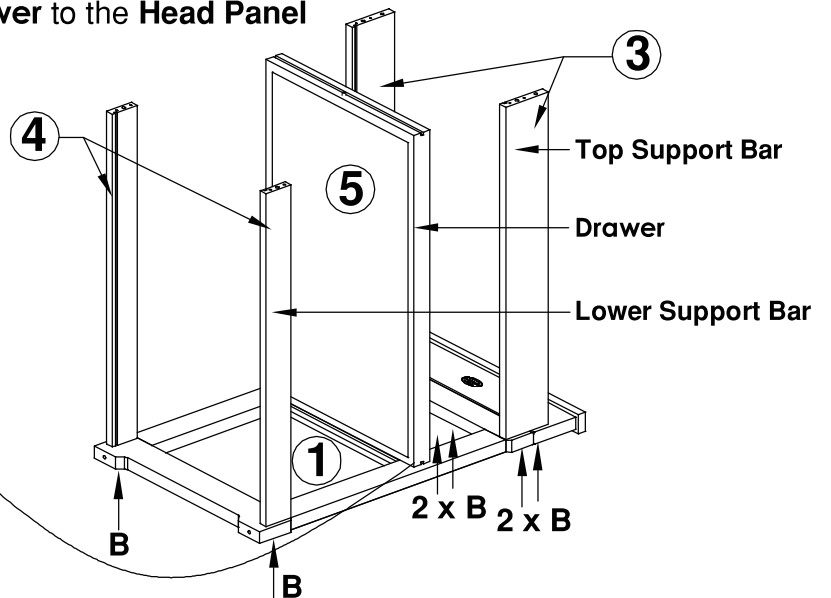

B x 6

## Step 3: Attach the Shelf Bases

Slide the two Shelf Bases (6) into the groove in the Top Support Bar (3) and Lower Support Bar (4). Make sure the stained side is facing up.

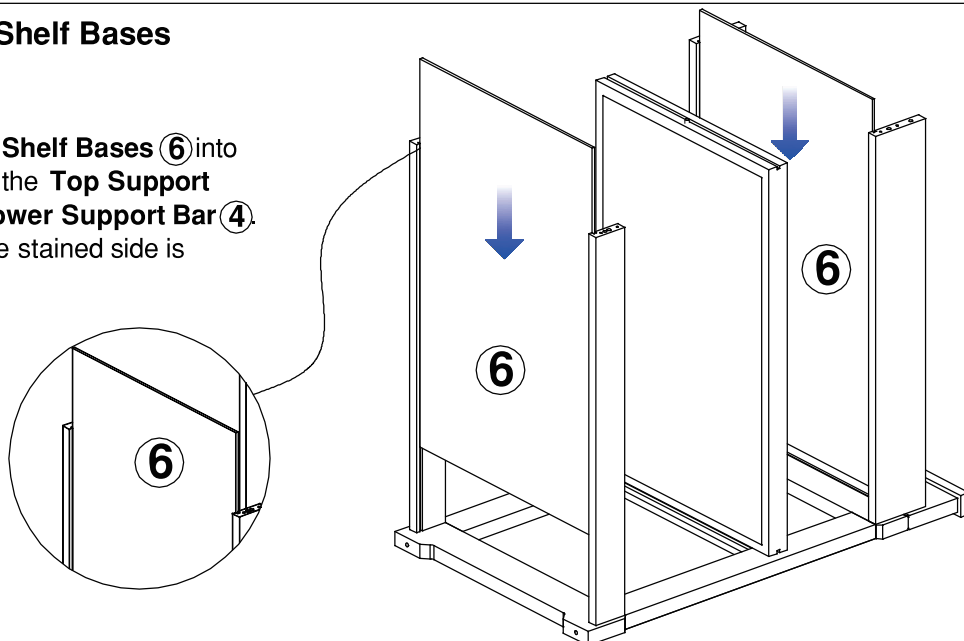

# ASSEMBLY INSTRUCTIONS

## Step 4: Attach the Foot Panel

Attach the **Foot Panel** (2) onto the **Support Bars** (3) (4) and **Drawer** (5), secure using **6 x B** connecting bolts.

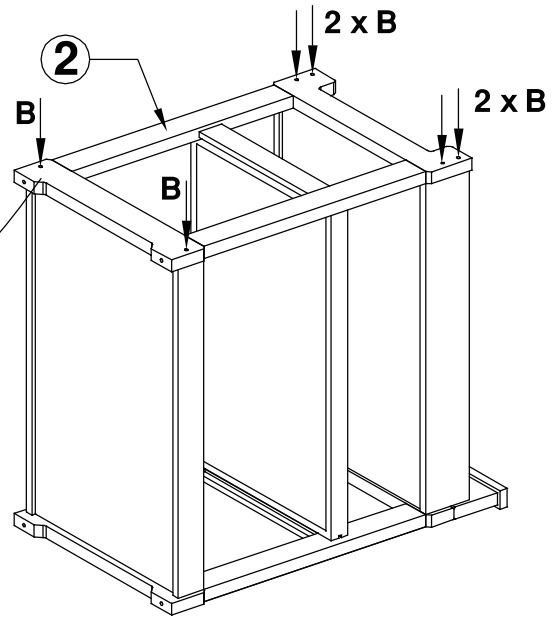
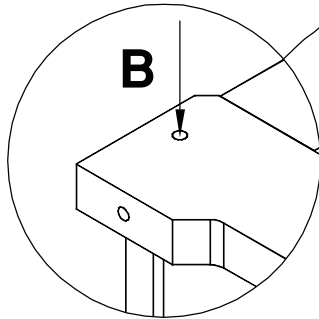

B x 6

## Step 5: Attach the Castors

Push the **4 x Castors** into the castor sleeves holes at the bottom of the **Head Panel** (1) and **Foot Panel** (2).

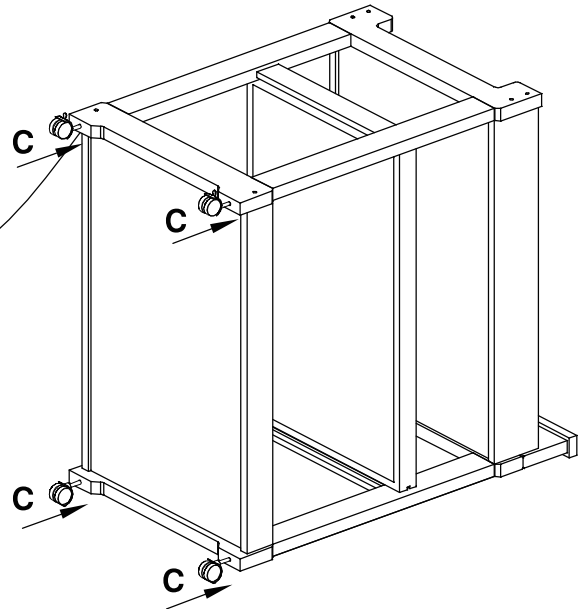
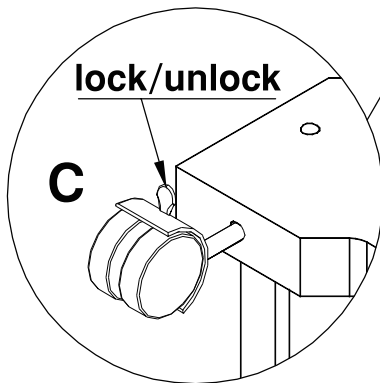

C x 4

**Note:** After standing your **Changer** upright push down on the corners to make sure **Castors** click into place.

Put the changing pad onto the top of the **Changer**.

RECOMMENDED CHANGING PAD SIZE 800mm X 480mm X 25mm. This **Changer** has been manufactured for use with a pad which measures 480mm wide by 800mm long and a maximum thickness of 25mm.

## ⚠ WARNING:

- \* Please ensure that the brakes on all four castors are released before moving the cradle;
- \* Regularly check your cradle to ensure that all the rocking bars are in their correct positions, and the capping nuts are tightly fitted.

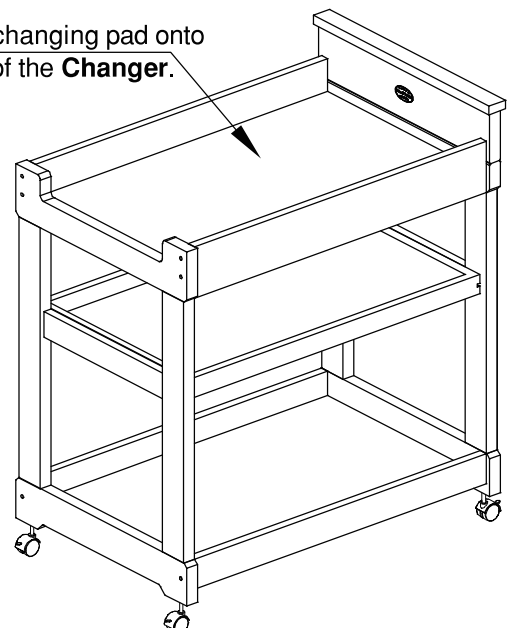

# Boori Furniture

**NOTE:** Use only spare parts approved by the manufacturer

**FOR THE UK**

**EN 12221-1/-2:2008+A1:2013**

**⚠ WARNING:** Do not leave the child unattended

\* This product is not intended to be used as a table. Use of the product without instruction may result in death or serious injury to your child from falling.

Follow all instructions on attaching and using the changer.

\* When lockable castors/wheels are fitted, they shall be locked when the changing unit is in use.

\* All assembly fittings shall always be correctly tightened and checked regularly.

\* Be aware of the risk of open fires and other sources of strong heat, such as electric bar fires, gas fires, etc. in the near vicinity of the changing unit.

\* Recommended pad size is shown on carton marking.

\* This product is intended for children under 12 months, and lighter than 11kg.

\* Any additional or replacement parts shall only be obtained from the manufacturer or distributor.

\* Not to use the changing unit when any part is broken, torn or missing.

**FOR THE USA**

**( ASTM F 2388:2009 )**

**⚠ WARNING:** Do not leave the child unattended

## 1. **FALL HAZARD:**

To prevent death or serious injury, always keep child within arm's reach.

2. Read all instructions before use of the changing table, add-on changing unit, or contoured changing pad.

3. Keep instructions for future use.

4. Do not use changing table, add-on changing unit, or contoured changing pad if it is damaged or broken.

5. Recommended pad size is shown on carton marking.

6. This product is intended for children under 12 months, and lighter than 11kg.