

Boori

Universal

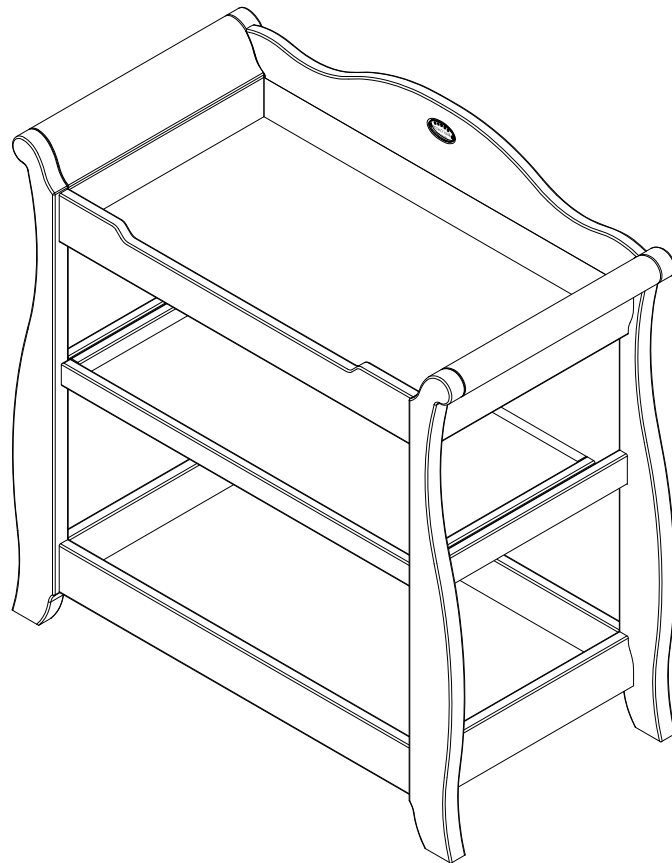

Sleigh 3 Tier Changer



IMPORTANT:

**PLEASE READ THE INSTRUCTIONS CAREFULLY
AND KEEP FOR FUTURE REFERENCE**



**IMPORTANT: THE ASSEMBLY OF THIS PRODUCT REQUIRES TWO PEOPLE
READ ALL INSTRUCTIONS BEFORE ASSEMBLY AND USE OF THE PRODUCT.**

Boori Australia Pty Ltd
18-20 Charles Street
St. Marys Sydney NSW
2760 Australia
Ph: 61 2 9833 3769
Fax: 61 2 9673 4240
www.boori.com.au



Boori (Europe) Ltd
Unit 1, Transigo
Gables Way
Thatcham, Berkshire,
RG19 4 JZ
Ph: (44) 016 3529 5670
Fax: (44) 016 3587 7552
www.boori.co.uk

Halim & Boori Company 10F.
Halim INT'L B/D, #1674-4,
Seocho-Dong, Seocho-Gu,
Seoul, Korea
Tel: +82-2-598-1470
Fax: +82-2-583-8885
E-mail: ted@boori.co.kr
Postal code: 137-725.

ブーリジャパン(株)
〒541-0057
大阪府大阪市中央区北久宝寺町
4-2-10
Ph: 06-4963-3939
Fax: 06-4963-3900
E-mail: info@boori.co.jp

Instructions for Boori Universal Sleigh 3 Tier Changer (B-SLCH)

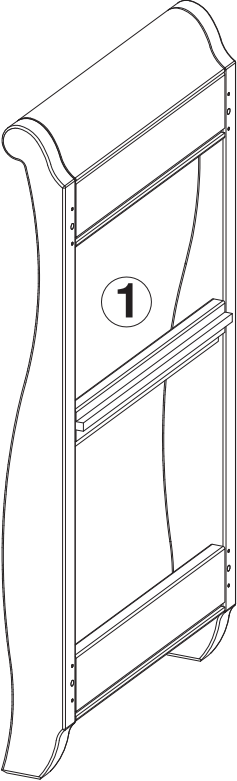
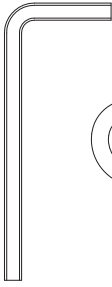
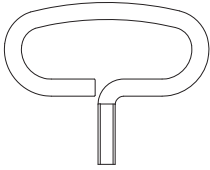
Hardware and Parts List

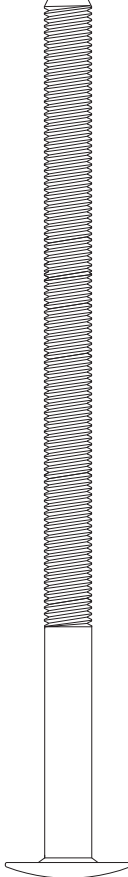
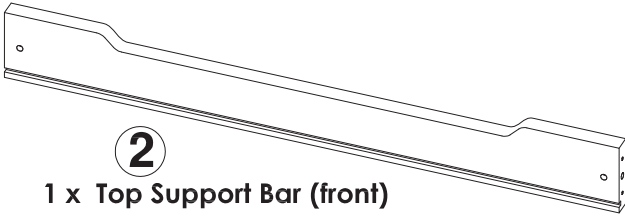
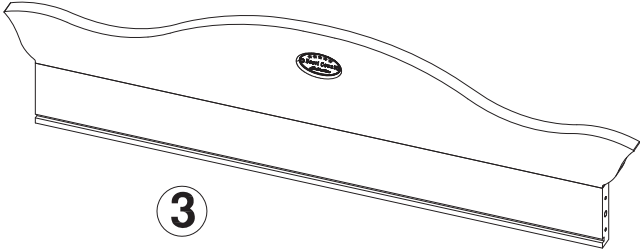
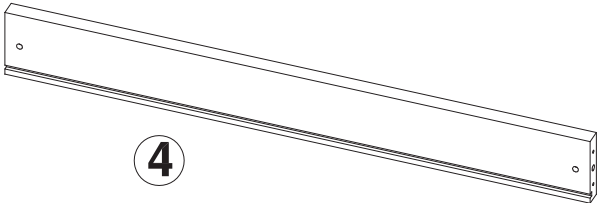
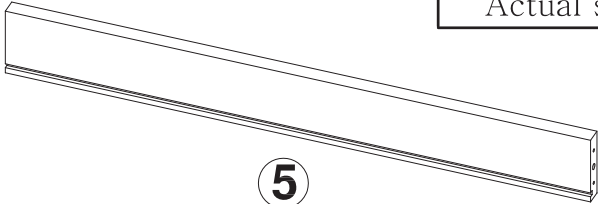
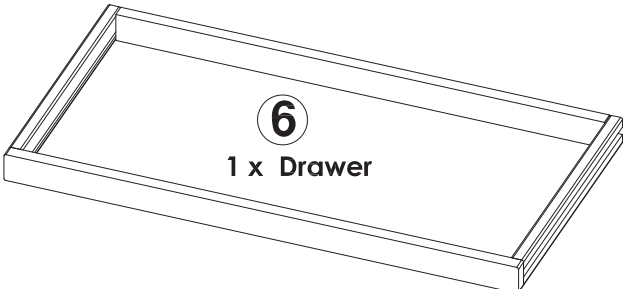
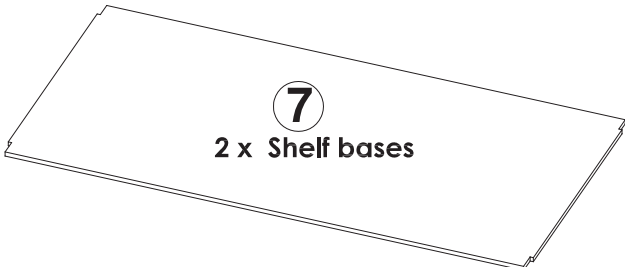
	2 x Allen Keys	16 x Iron dowels	4 x 80mm Connecting bolts	4 x 110mm Connecting bolts
2 x End Heads 	 	A 	B  Actual size	C  Actual size
	1 x Top Support Bar (front) 			
1 x Top Support Bar (back) 				
1 x Lower Support Bar (front) 				
1 x Lower Support Bar (back) 				
1 x Drawer 				
2 x Shelf bases 				

ASSEMBLY INSTRUCTIONS

Step 1: Prepare the two End Panels

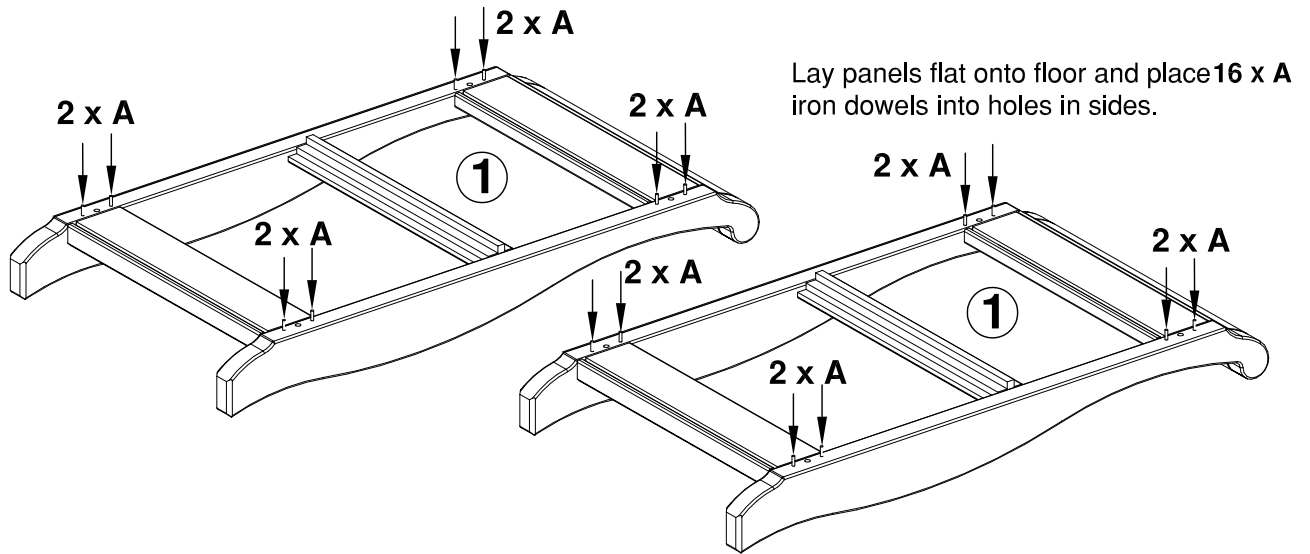

A x 16

Step 2: Attach the Support Bars and Drawer to the End Panel

Note: Make sure the groove on the Support Bars for the Shelf Base are facing inward.

Lay a **End Panel** ① onto its side and secure the **Top Support Bars** ② ③ using 2 x B connecting bolts and secure the **Lower Support Bars** ④ ⑤ using 2 x C connecting bolts respectively.

Lower Support Bar (back) ⑤

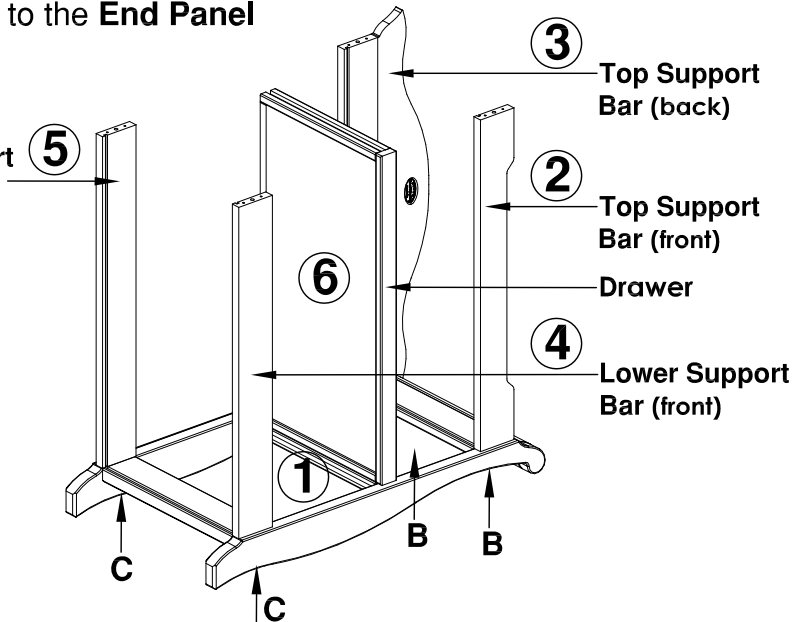

B x 2 C x 2

Step 3: Attach the Shelf Bases

Slide the two **Shelf Bases** ⑦ into the groove in the **Top Support Bars** ② ③ and **Lower Support Bars** ④ ⑤. Make sure the stained side is facing up.

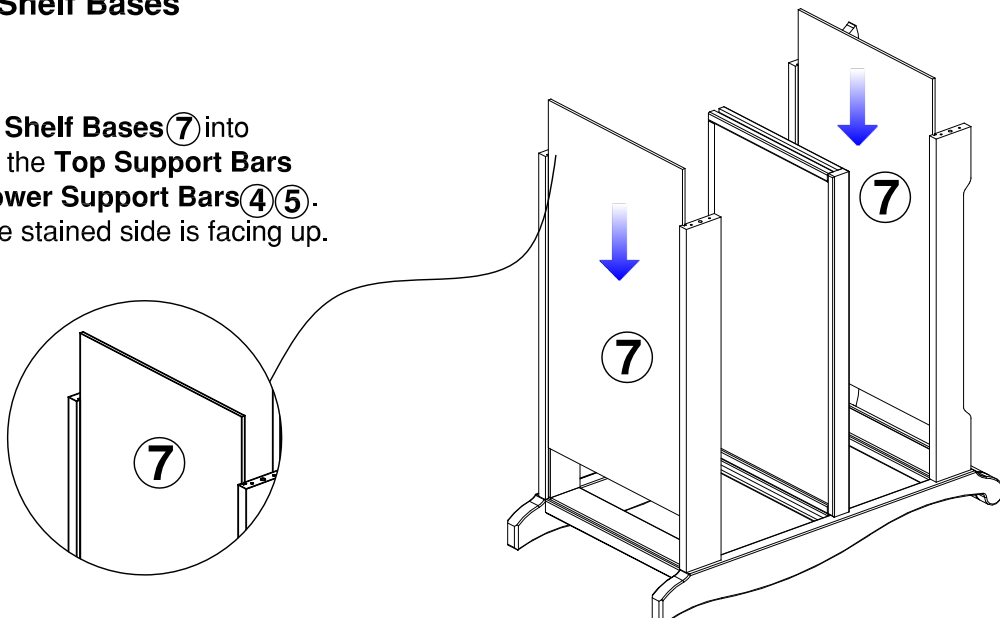

ASSEMBLY INSTRUCTIONS

Step 4: Attach the other End Panel

Attach the other **End Panel** ① to the **Top Support Bars** ② ③, **Lower Support Bars** ④ ⑤ and **Drawer** ⑥, secure using **2 x B** connecting bolts and **2 x C** connecting bolts.

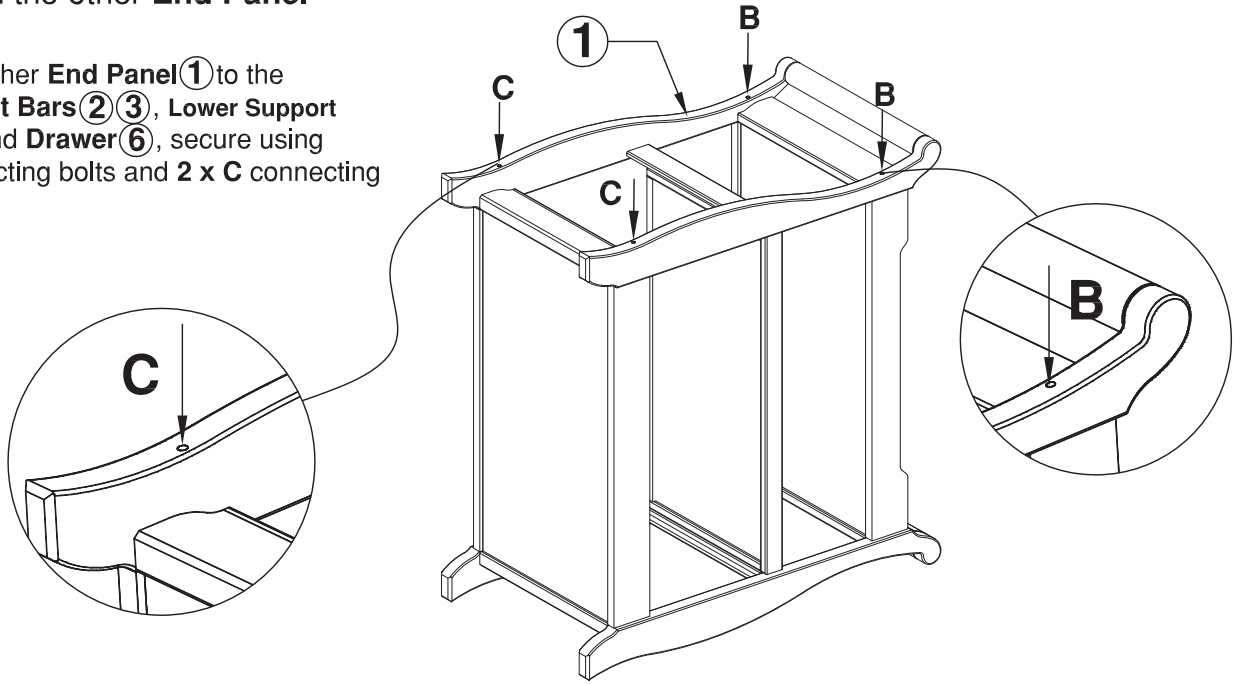

B x 2 **C x 2**

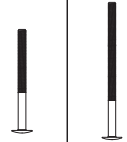

Note: RECOMMENDED CHANGING PAD SIZE 800mm X 480mm X 25mm. This **Sleigh Changer** has been manufactured for use with a pad which measures 480mm wide by 800mm long and a maximum thickness of 25mm.

Put the changing pad onto the top of the **Changer**.

