

# Boori

## Universal

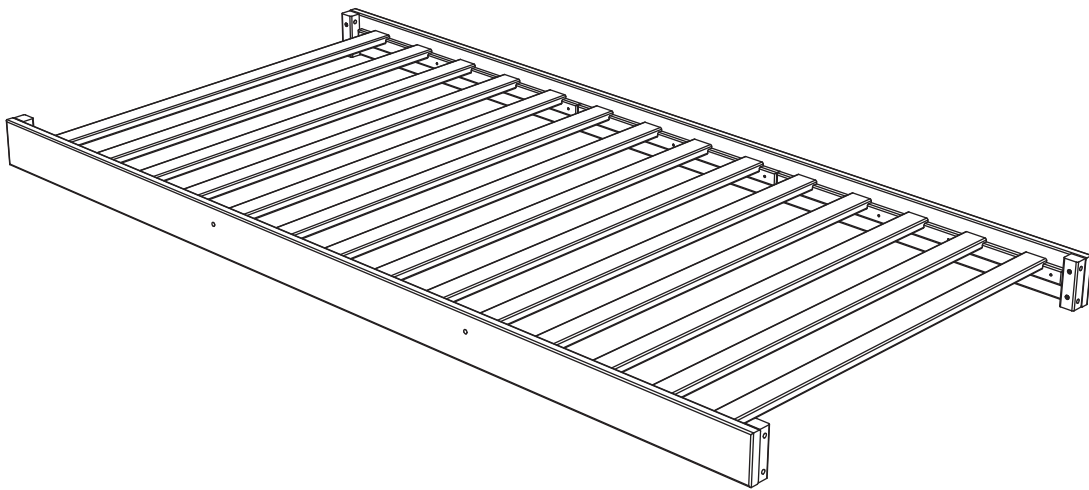

### *Expandable*<sup>™</sup> Conversion Kit



**IMPORTANT:  
PLEASE READ THE INSTRUCTIONS CAREFULLY  
AND KEEP FOR FUTURE REFERENCE**



**IMPORTANT: THE ASSEMBLY OF THIS PRODUCT REQUIRES TWO PEOPLE  
READ ALL INSTRUCTIONS BEFORE ASSEMBLY AND USE OF THE PRODUCT.**

Boori Australia Pty Ltd  
18-20 Charles Street  
St. Marys Sydney NSW  
2760 Australia  
Ph: 61 2 9833 3769  
Fax: 61 2 9673 4240  
www.boori.com.au

Boori (Europe) Ltd  
Unit 1, Transigo  
Gables Way  
Thatcham, Berkshire,  
RG19 4JZ  
Ph: (44) 016 3529 5670  
Fax: (44) 016 3587 7552  
www.boori.co.uk

Halim & Boori Company 10F.  
Halim INT'L B/D, #1674-4,  
Seocho-Dong, Seocho-Gu,  
Seoul, Korea  
Tel: +82-2-598-1470  
Fax: +82-2-583-8885  
E-mail : ted@boori.co.kr  
Postal code: 137-725.

ブーリジャパン(株)  
〒541-0057  
大阪府大阪市中央区北久宝寺町  
4-2-10  
Ph : 06-4963-3939  
Fax : 06-4963-3900  
E-mail : info@boori.co.jp

## Instructions for Boori Expandable™ Conversion Kit (B-EXCK)

### Hardware and Parts List

Allen Keys	12 x 47 mm Connecting bolts		
<p><b>NOTE:</b> Use only spare parts approved by the manufacturer.</p>			

## ASSEMBLY INSTRUCTIONS

### Step 1: Attach the Base Rails.

A: Connect the **Base Rails** to the **End Panels** with 8 x A .

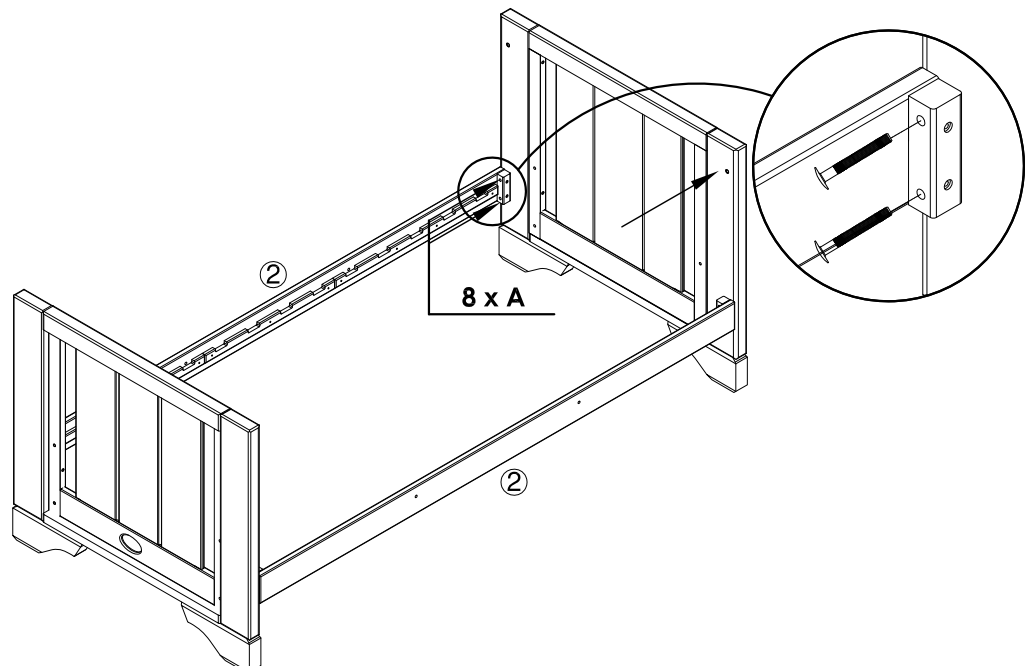

# ASSEMBLY INSTRUCTIONS

## **Step 2:** Attach the **Mattress Slats(A)**

**A:** Connect the two **Mattress Slats(A)** to the Base Rails with **4 x A** connecting bolts.

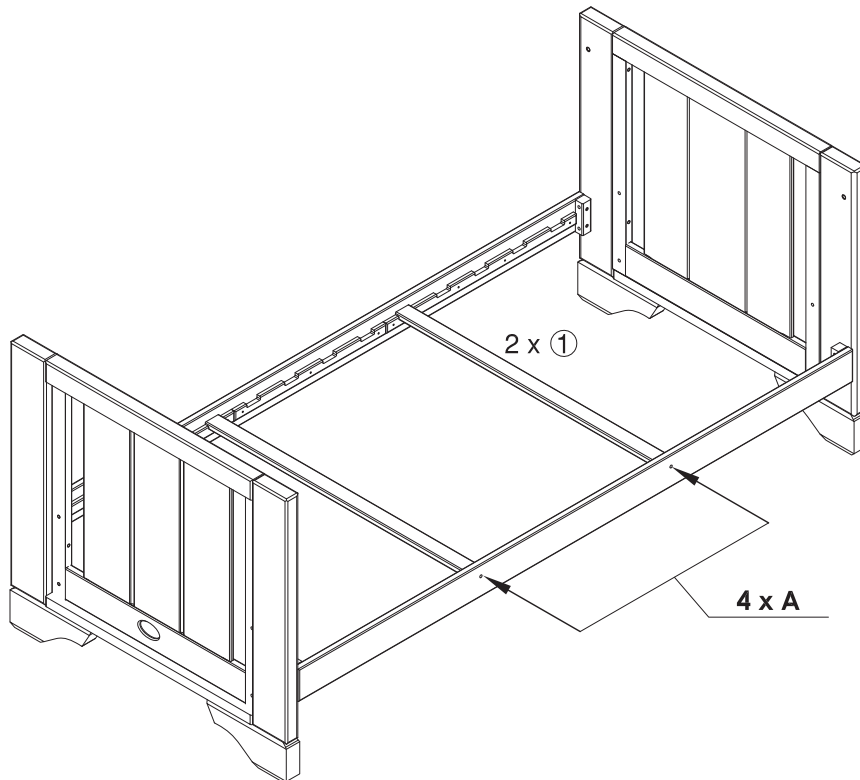

## **Step 3:** Attach the **Mattress Slats(B)**

**A:** Put the **12 x Mattress Slats(B)** on the Base Rails.

**B:** Tighten all connecting bolts

