

# Boori

## Universal



### Change Top Extender For Chests

通用三斗柜台面扩展板

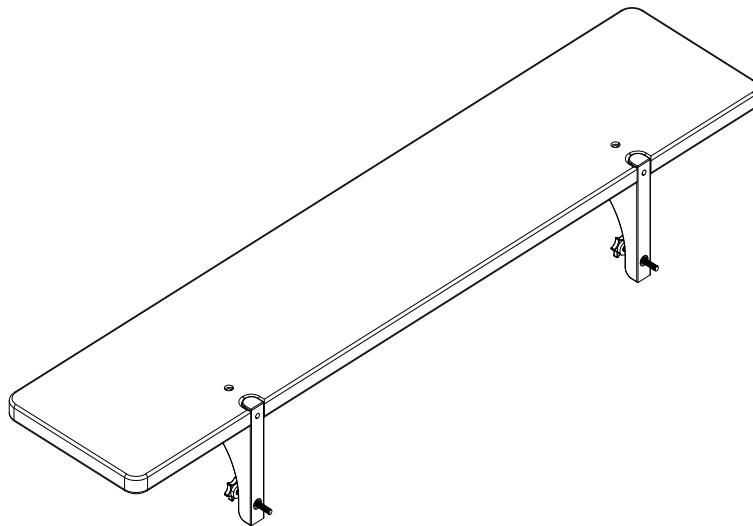

**IMPORTANT:**  
**PLEASE READ THE INSTRUCTIONS CAREFULLY**  
**AND KEEP FOR FUTURE REFERENCE**

重要：请仔细阅读此说明书，并妥善保管以便日后参考。

B-CHTE

**Boori Australia Pty Ltd**  
 26 Peter Brock Drive  
 Eastern Creek Sydney  
 NSW 2766 Australia  
 Tel: +61 2 9833 3769  
 Fax: +61 2 9673 4240  
 www.boori.com.au

**Boori (Europe) Ltd**  
 Unit 1 Riverside House,  
 Mill Lane, Newbury,  
 Berkshire, RG 14 5QS UK  
 Tel: +44 016 3529 5670  
 Fax: +44 016 3587 7552  
 www.boori.co.uk

**Halim & Boori Company**  
 10F, Halim INT'L B/D, #1674-4,  
 Seocho-Dong, Seocho-Gu,  
 Seoul, Korea  
 Tel: +82 2598 1470  
 Fax: +82 2583 8885  
 E-mail: ted@boori.co.kr  
 Postal code: 137-725.

ブーリジャパン株式会社  
 〒141-0031  
 東京都品川区西五反田  
 7-22-17 TOCビル5F  
 TEL: 03-6420-0024  
 EMAIL: info@boori.co.jp  
 HP: www.boori.jp

上海薇奈莎商贸有限公司  
 博瑞儿童用品(上海)有限公司  
 上海市青浦区徐泾镇华徐公路577号  
 VEG微格创意园A8-10室  
 邮编: 201702  
 电话: +86 21 5296 6600  
 传真: +86 21 5296 6636  
 网址: www.boori.com.cn

## Universal Change Top Extender For Chests (B-CHTE)

**Dimensions:** 990mm\*210mm\*145mm

产品规格 : 990mm\*210mm\*145mm

**Main Materials:** Australian Araucaria

主要材质: 澳洲南洋杉

### Hardware/五金单

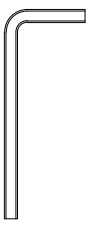
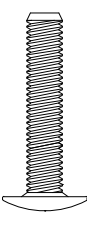
A x 1	B x 4
	
M5*65*25mm	M5*35mm

### Parts List/部件清单

**Note:** Use only spare parts approved by the manufacturer.

注意: 仅限使用制造商提供的产品零配件及五金。

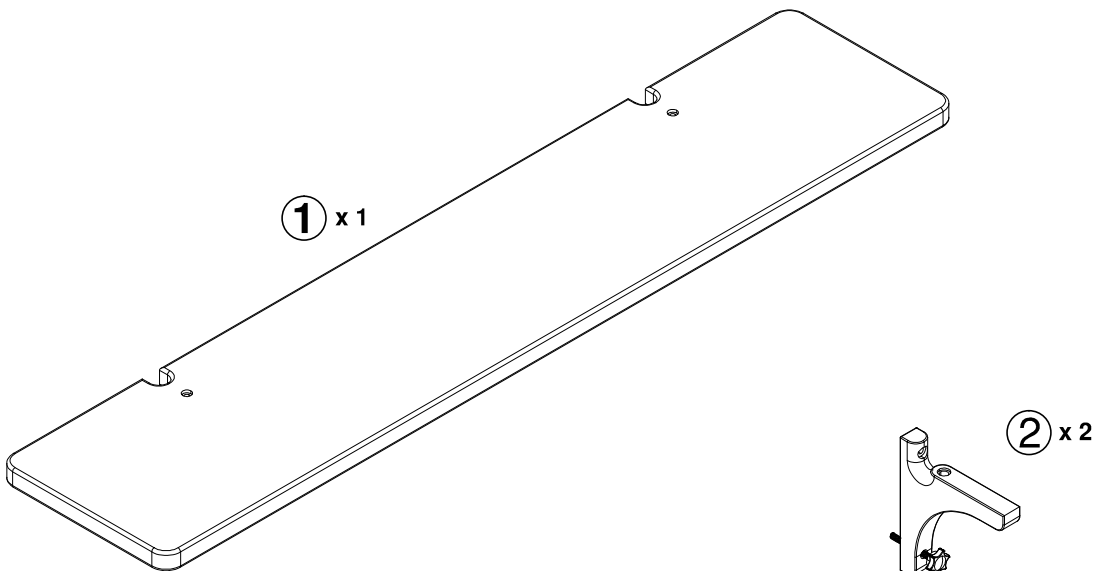

# Assembly / 安装说明

## 1

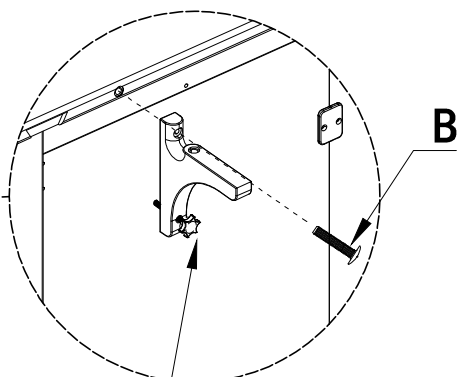
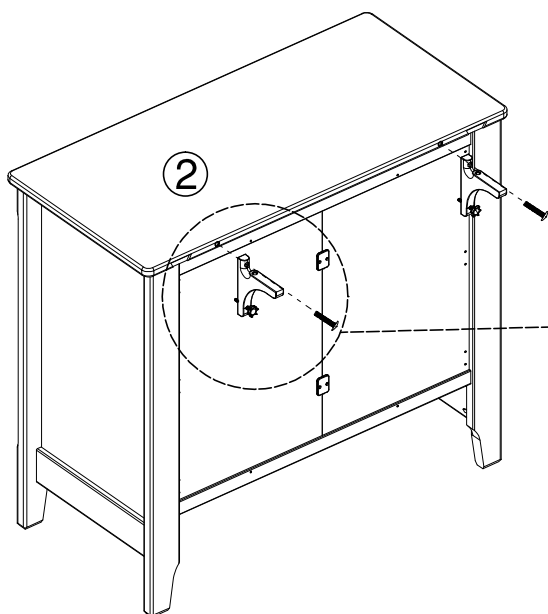

Adjust the star knob bolt so that it applies a bit of pressure to the backboard of the chest.

调节手柄螺丝，贴紧斗柜的背板



Bx2

## 2

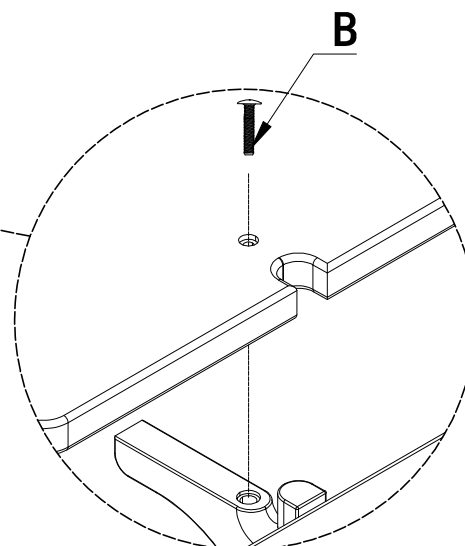
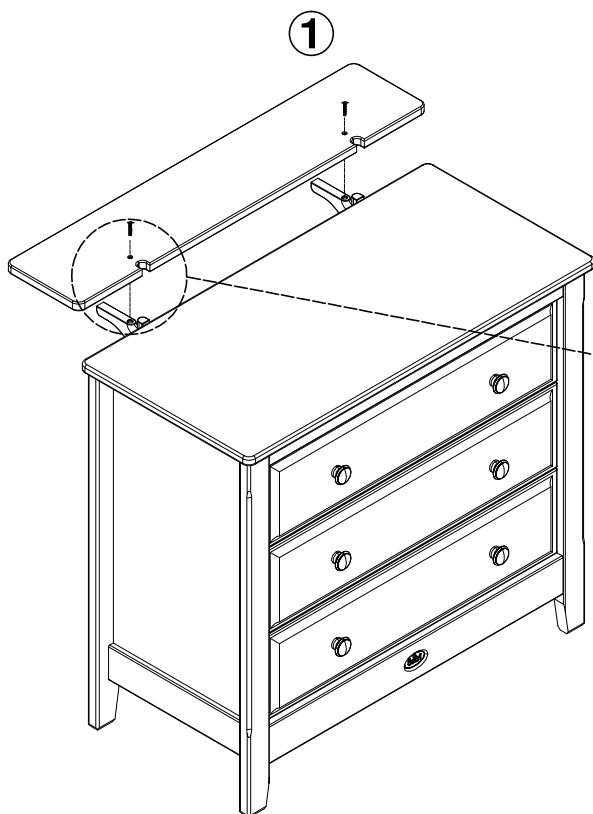

Bx2

3

Front  
前面



Back  
背面

